

DESCRIPTION

The 8228 is a 4096 Bit Bipolar Read Only Memory organized as 1024 words by 4 bits per word. Available in a 16 pin dual in-line package, the 8228 can provide very high bit packing density by replacing four standard 256X4 ROMs.

The 8228 is fully TTL compatible and includes on-the-chip decoding. Typical access time is 50ns with a power consumption of only .125mW per bit.

The standard 8228 ROM pattern is the USASCII Row Character Generator code; however, custom patterns are also available. The standard pattern is specified as the N8228I - CB162, while custom circuits are identified as N8228I - CXXX. A truth table/order blank is included on page 4-46 for ordering custom patterns.

See page 4-35 for CB162 Pattern and USASCII Row Character Generator.

FEATURES

- BUFFERED ADDRESS LINES
- ON THE CHIP DECODING
- TOTEM POLE OUTPUTS
- DIODE PROTECTED INPUTS
- 16 PIN PACKAGE (1/3 SIZE OF 24 PIN PACKAGE)

APPLICATIONS

MICROPROGRAMMING
HARDWIRED ALGORITHMS
CHARACTER RECOGNITION
CHARACTER GENERATION
CONTROL STORE

BLOCK DIAGRAM

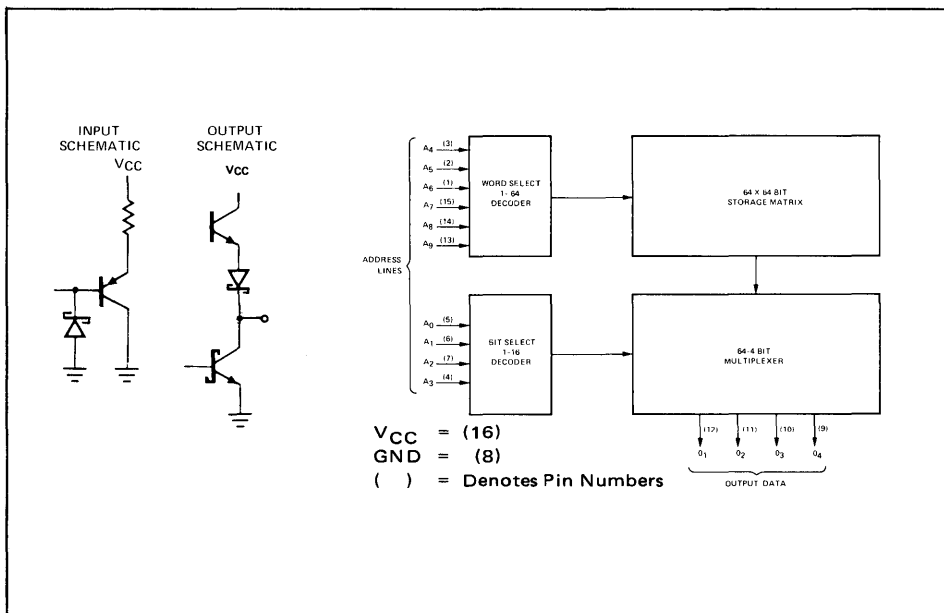

PIN CONFIGURATION

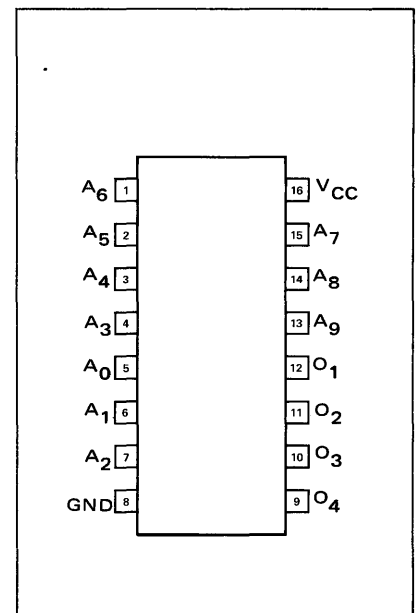

ELECTRICAL CHARACTERISTICS 0°C ≤ T_A ≤ 75°C; 4.75V ≤ V_{CC} ≤ 5.25V

CHARACTERISTICS	LIMITS				TEST CONDITIONS	NOTES
	MIN.	TYP.	MAX.	UNITS		
"0" Output Voltage	2.7	-10	-400	V	I _{out} = 11.2 mA I _{out} = -1.0 mA V _{in} = 0.45V V _{in} = 5.5V	
"1" Output Voltage						
"0" Input Current	1	25	μA			
"1" Input Current						
Input Voltage	2.0		.85	V		
"0" Level (V _{IL})						
"1" Level (V _{IH})						

ELECTRICAL CHARACTERISTICS (Cont'd)

CHARACTERISTICS	LIMITS				TEST CONDITIONS	NOTES
	MIN.	TYP.	MAX.	UNITS		
Input Clamp Voltage	-1.2			V	$I_{in} = -18mA$ O_1 to $O_3 = "0"$ $V_{OUT} = 0$ Volts	
Power Consumption		140	170	mA		
Output Short Circuit Current	-20		-70	mA		

SWITCHING CHARACTERISTICS $0 \leq T_A \leq 75^\circ C, 4.75 \leq V_{CC} \leq 5.25V$

CHARACTERISTICS	LIMITS				TEST CONDITIONS	NOTES
	MIN.	TYP.	MAX.	UNITS		
Access Time—Address to Output		50	70	ns		5

NOTES

1. Positive current is defined as into the terminal referenced.
2. No more than one output should be grounded at the same time.
3. Manufacturer reserves the right to make design and process changes and improvements.
4. Applied voltages must not exceed 6.0V. Input currents must not exceed $\pm 30mA$. Output currents must not exceed $\pm 100mA$. Storage temperature must be between $-60^\circ C$ to $+150^\circ C$.
5. Rise and fall time for this test must be less than 5ns. Input amplitudes are 2.8V and all measurements are made at 1.5V.

AC TEST FIGURE AND WAVEFORM

