



无锡市至诚微电子  
[www.zcc-china.cn](http://www.zcc-china.cn)

---

# **ZCC2213**

## **Datasheet**

1 Cell Li-ion/Polymer Battery Charge Balance IC

### Table of Contents

<b>1. GENERAL DESCRIPTION .....</b>	<b>4</b>
<b>2. FEATURE .....</b>	<b>4</b>
<b>3. APPLICATION .....</b>	<b>4</b>
<b>4. BLOCK DIAGRAM.....</b>	<b>5</b>
<b>5. ORDERING INFORMATION .....</b>	<b>5</b>
<b>6. MODEL LIST.....</b>	<b>6</b>
6.1. Electrical Parameter Option .....	6
6.2. Characteristic Code- Other Function Option.....	6
<b>7. PIN CONFIGURATION AND PACKAGE MARKING INFORMATION .....</b>	<b>6</b>
<b>8. ELECTRICAL CHARACTERISTICS .....</b>	<b>7</b>
8.1. Absolute Maximum Ratings .....	7
8.2. Electrical Characteristics (Excluding Delay Time) .....	7
<b>9. EXAMPLE CIRCUIT OF BATTERY CHARGE BALANCE IC APPLICATION.....</b>	<b>8</b>
<b>10. DESCRIPTION OF OPERATION .....</b>	<b>9</b>
10.1. Normal Status.....	9
10.2. Overcharge Status .....	9
10.3. Standby Status .....	9
<b>11. CHARACTERISTIC CURVE (TYPICAL VALUE).....</b>	<b>10</b>
<b>12. PACKAGE INFORMATION.....</b>	<b>11</b>
12.1. SOT-23-6 Package.....	11
<b>13. TAPE &amp; REEL INFORMATION.....</b>	<b>12</b>
13.1. Tape & Reel Information ---SOT-23-6 (Type 1).....	12
13.2. Tape & Reel Information ---SOT-23-6 (Type 2).....	13
<b>14. REVISION HISTORY .....</b>	<b>14</b>

### 1. General Description

The series of ZCC2213 is created for multi-cell battery packs to single-cell lithium-ion battery Charge balance control, electrical level monitoring ICs and it also comprises high-accuracy voltage detection circuit and delay circuit.

### 2. Feature

ZCC2213 series IC equips with the following features:

#### (1) High Precision Voltage Detection Circuit

- Overcharge detection voltage      4.000~4.500V      Precision:  $\pm 25\text{mV}$
- Overcharge release voltage      3.800~4.500V      Precision:  $\pm 35\text{mV}$
- Standby detection voltage      2.70V      Precision:  $\pm 15\%$
- Standby release voltage      2.70V      Precision:  $\pm 15\%$

(2) Delay times are generated by an internal circuit (external capacitors are unnecessary).

#### (3) Low consumption current

- Operation mode      Typ. value  $2.5\mu\text{A}$ , max. value:  $3.5\mu\text{A}$  ( $V_{\text{DD}}=3.9\text{V}$ )
- Standby mode      Max. value:  $0.5\mu\text{A}$  ( $V_{\text{DD}}=2.7\text{V}$ )

(4) Wide operation temperature range:  $-40^{\circ}\text{C} \sim +85^{\circ}\text{C}$

(5) Small package: SOT-23-6

(6) The ZCC2213 series are Halogen-free, green package

### 3. Application

- Multi-cell Li-ion rechargeable battery packs

### 4. Block Diagram

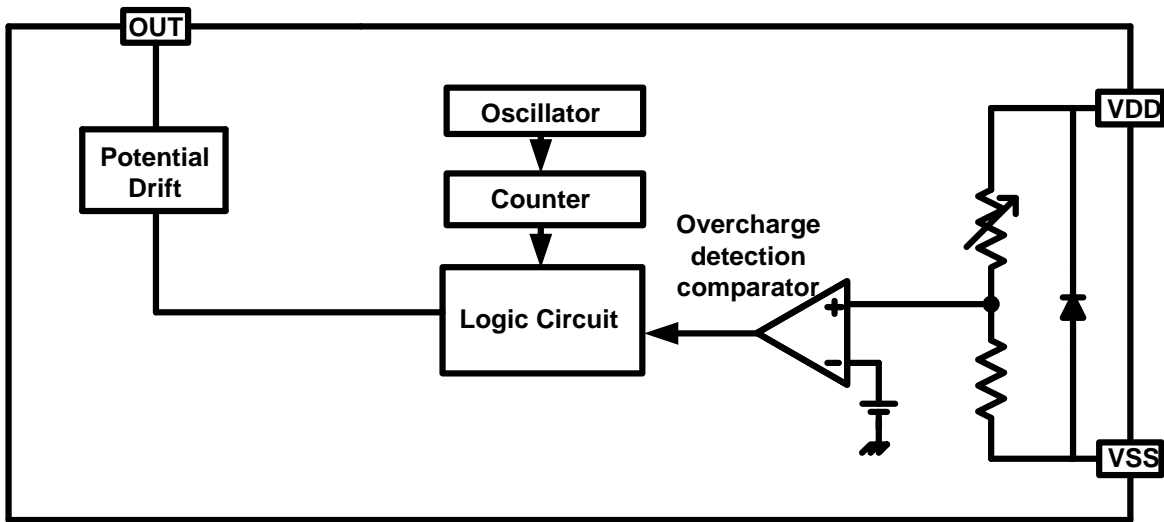

### 5. Ordering Information

- Product Name Definition

ZCC2213—#%3&

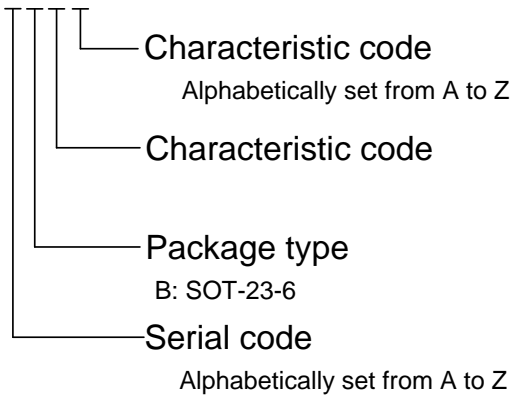

## 6. Model List

### 6.1. Electrical Parameter Option

- SOT-23-6 Package

Table 1 Electrical Parameter Select Table

Parameter	Over-charge Detect Voltage	Over-charge Release Voltage	Characteristic Code
Model No.	V <sub>CU</sub>	V <sub>CR</sub>	-
ZCC2213-AB3B	4.200±0.025V	4.200-0.035V,4.200+0.025V	B
ZCC2213-BB3A	4.200±0.025V	4.190±0.035V	A
ZCC2213-CB3A	4.180±0.025V	4.180-0.035V,4.180+0.025V	A

**Remark:**

1. Table 1 lists various electrical parameters typical value, See Table 5 for each electrical parameter accuracy.
2. See Table 2 for other features characteristic code corresponding.
3. Please contact our sales office for the products with detection voltage value other than those specified above.

### 6.2. Characteristic Code- Other Function Option

Table 2 Characteristic Code

Characteristic Code	OUT Effective Action
A	Balance control N-MOSFET; OUT output status L→H effective
B	Balance control P-MOSFET; OUT output status H→L effective

## 7. Pin Configuration and Package Marking Information

- SOT-23-6 Package

Table 3 SOT-23-6 Package

Pin	Symbol	Description
1	NC	No connection
2	VDD	Power end, positive power input pin
3	VSS	Grounding end, negative power input pin
4	NC	No connection
5	NC	No connection
6	OUT	Charge balance, control MOSFET gate and connection end

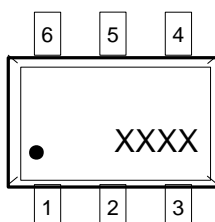

- B: Product No.
- #: Serial code, from A~Z
- 3: Characteristic code
- &: Characteristic code, from A~Z
- XXXX: Traceability code

## 8. Electrical Characteristics

### 8.1. Absolute Maximum Ratings

**Table 4 Absolute Maximum Rating** (VSS=0V, Ta=25°C unless otherwise specified)

Item	Symbol	Rating	Unit
Input voltage between VDD and VSS pin	V <sub>DD</sub>	VSS-0.3~VSS+10	V
OUT output voltage	V <sub>OUT</sub>	VSS-0.3~VDD+0.3	V
Operating Temperature Range	T <sub>OP</sub>	-40~+85	°C
Storage Temperature Range	T <sub>ST</sub>	-40~+125	°C
Power dissipation	P <sub>D</sub>	250	mW

### 8.2. Electrical Characteristics

**Table 5 Electrical Characteristics** (VSS=0V, Ta=25°C unless otherwise specified)

Item	Symbol	Condition	Min.	Typ.	Max.	Unit
<b>Input Voltage/Power Dissipation</b>						
VDD-VSS Operation Voltage	V <sub>DSOP1</sub>	-	1.5	-	8	V
Operation Current	I <sub>DD</sub>	V <sub>DD</sub> =3.9V	-	2.0	3.5	μA
Standby Current	I <sub>SB</sub>	V <sub>DD</sub> =2.0V	-	-	0.5	μA
<b>Detection Voltage</b>						
Overcharge Detection Voltage	V <sub>CU</sub>	4.0~4.5V adjustable	V <sub>CU</sub> -0.025	V <sub>CU</sub>	V <sub>CU</sub> +0.025	V
		4.0~4.5V adjustable -5°C~55°C (*1)	V <sub>CU</sub> -0.035	V <sub>CU</sub>	V <sub>CU</sub> +0.035	V
Overcharge Release Voltage	V <sub>CR</sub>	3.8~4.5V adjustable V <sub>CR</sub> ≠V <sub>CU</sub>	V <sub>CR</sub> -0.035	V <sub>CR</sub>	V <sub>CR</sub> +0.035	V
		3.8~4.5V adjustable V <sub>CR</sub> =V <sub>CU</sub>	V <sub>CR</sub> -0.035	V <sub>CR</sub>	V <sub>CR</sub> +0.025	V
Standby Release Voltage	V <sub>SB</sub>		2.3	2.7	3.1	V
<b>Delay Time</b>						
Overcharge Detection Delay Time	T <sub>OC</sub>	V <sub>DD</sub> =3.9V→4.5V	200	250	300	ms
<b>Control Pin Output Voltage</b>						
OUT output high voltage	V <sub>OUT_H</sub>		VDD-0.1	VDD-0.02	-	V
OUT output low voltage	V <sub>OUT_L</sub>		-	0.1	0.5	V

Remark: \*1 Parameters of this temperature range is design-guaranteed not actual test by high/low temperature.

### 9. Example Circuit of Battery Charge Balance IC Application

Example application of ZCC2213 xxxA using N-MOSFET of charge balance

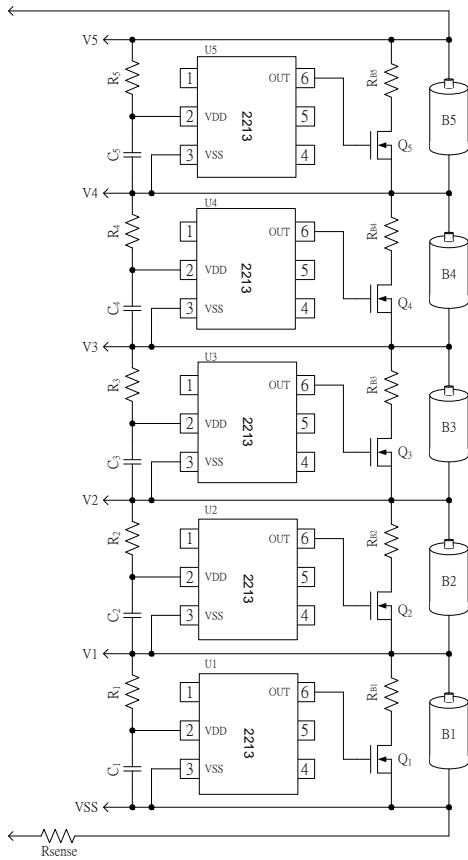

Example application of ZCC 2213-xxxB using P-MOSFET of charge balance

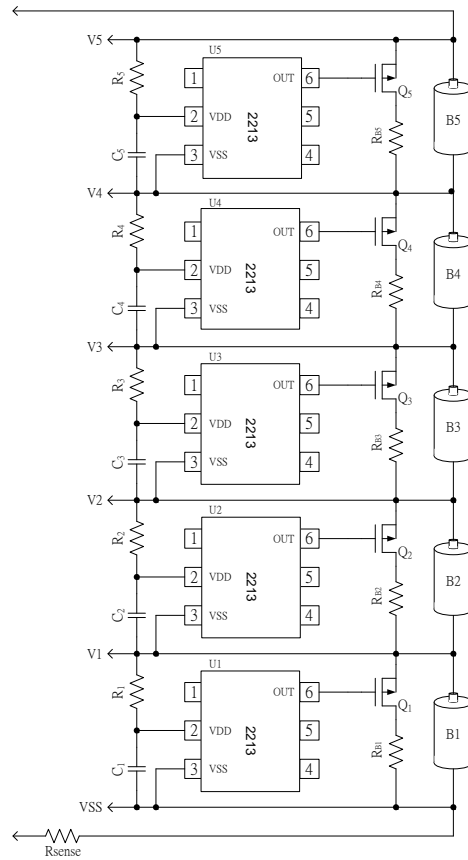

Symbol	Device Name	Purpose	Min.	Typ.	Max.	Remark
R <sub>1-5</sub>	Resistor	Limit current, stabilize VDD and strengthen ESD protection	100Ω	<b>100Ω</b>	200Ω	*1
R <sub>B1-5</sub>	Resistor	Charge balance flow loading				*2
C <sub>1-5</sub>	Capacitor	Filter, stabilize VDD	0.01μF	<b>0.1μF</b>	1.0μF	*3
Q <sub>1-5</sub>	MOSFET	Charge Balance Control	-	-	-	*4

\*1. If R<sub>1-5</sub> connects with an over-spec resistor, battery accuracy may be influenced due to R<sub>1-5</sub> voltage drop that caused by current consumption. When a charger is connected in reversed, the current flows from the charger to the IC. At this time, if R<sub>1-5</sub> is too high, the voltage between VDD pin and VSS pin may exceed the absolute maximum rating.

\*2. If R<sub>B1-5</sub> connects with an under-spec resistor, the charge current will become all of a sudden when battery voltage exceeded overcharge detection voltage (VCU), which may lead to charge over-current and the circuit will be protected and could not be charged.

\*3. C<sub>1-5</sub> can stabilize the supply voltage of VDD, the value of C<sub>1-5</sub> should larger than 0.01μF.

\*4. Select N-MOSFET or P-MOSFET according to different model no.

## 10. Description of Operation

### 10.1. Normal Status

This IC continuing monitor the battery voltage connected between VDD and VSS to control charge balance operation. When battery voltage is higher than overcharge detection voltage ( $V_{CU}$ ), OUT pin output low potential to control P-MOSFET or output high potential to control N-MOSFET. When battery voltage under overcharge release voltage ( $V_{CR}$ ), OUT pin output high potential to control P-MOSFET or output low potential to turnoff N-MOSFET.

### 10.2. Overcharge Status

When charging battery under normal operation, once cell voltage exceeds over charge detection voltage ( $V_{CU}$ ) and this status continues longer than overcharge detection delay time ( $T_{OC}$ ), or when cell voltage lower than overcharge release voltage ( $V_{CR}$ ), **ZCC2213** series will start or turn off the MOSFET (OUT pin) that used for charging potential control, this status is called “Overcharge Status”, also “Charge Balance Control”.

There are two options of balancing control of MOSFET after overcharge status:

- (1) ZCC2213-xxxA series adopts N-MOSFET to implement charge balancing control
  - (a) Cell voltage exceeds overcharge detection voltage ( $V_{CU}$ ) during charge process and lasts longer than overcharge detection delay time ( $T_{OC}$ ), potential of OUT pin will generate L→H change to turn on N-MOSFET.
  - (b) Cell voltage lowers than overcharge release voltage ( $V_{CR}$ ) during charge process, OUT pin will generate H→L change to turn off N-MOSFET.
- (2) ZCC2213-xxxB series adopts P-MOSFET to implement charge balancing control
  - (a) Cell voltage exceeds overcharge detection voltage ( $V_{CU}$ ) during charge process and lasts longer than overcharge detection delay time ( $T_{OC}$ ), potential of OUT pin will generate H→L change to turn on P-MOSFET.
  - (b) Cell voltage lowers than overcharge release voltage ( $V_{CR}$ ) during charge process, OUT pin will generate L→H change to turn off P-MOSFET.

### 10.3. Standby Status

When discharging battery under normal operation, cell voltage drops under than standby detection voltage ( $V_{SB}$ ), it will reduce IC current consumption to the same level at standby mode, and this is called “Standby Mode”.

### 11. Characteristic Curve (Typical Value)

#### 1. Overcharge detection voltage, overcharge release voltage and overcharge delay time, standby detection voltage

(1)  $V_{CU}$  vs.  $T_a$

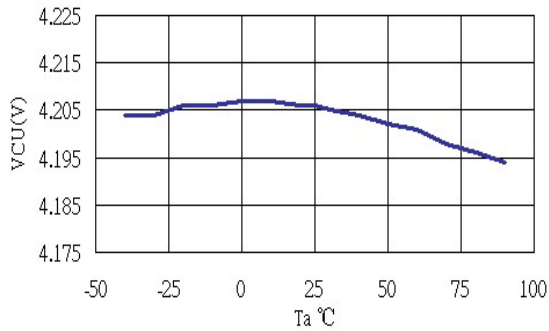

(2)  $V_{CR}$  vs.  $T_a$

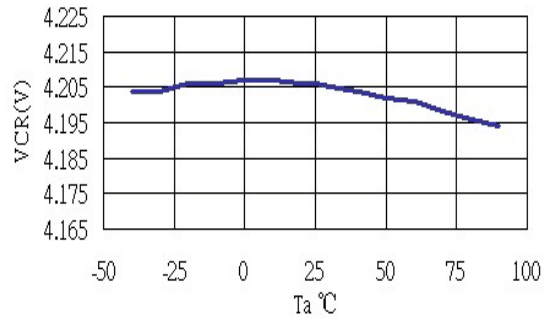

(3)  $T_{OC}$  vs.  $T_a$

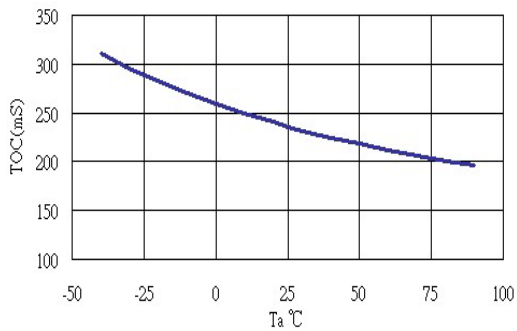

(4)  $V_{SB}$  vs.  $T_a$

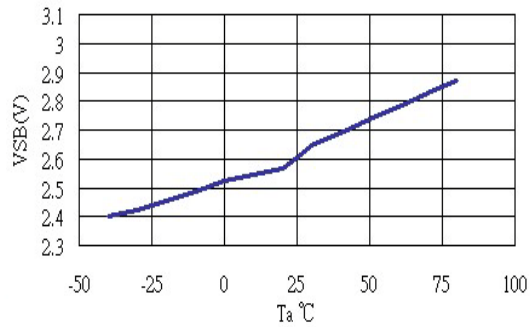

### 2. Power Consumption

(1)  $I_{DD}$  vs.  $T_a$

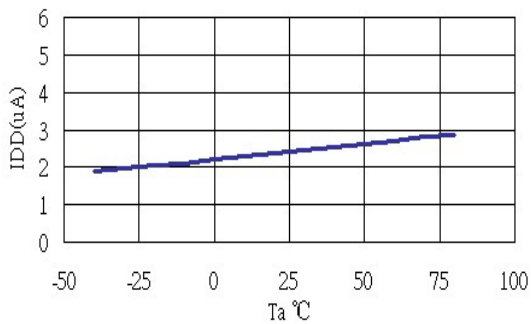

(2)  $I_{SB}$  vs.  $T_a$

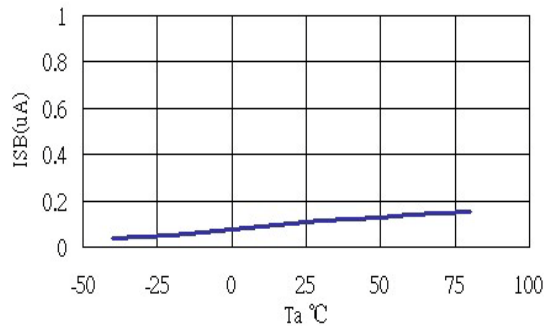

### 12. Package Information

#### 12.1. SOT-23-6 Package

Unit: mm.

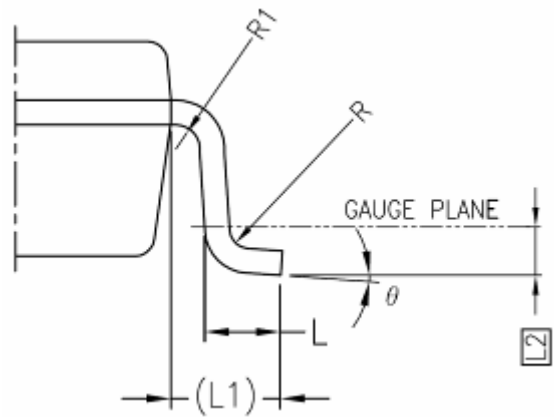
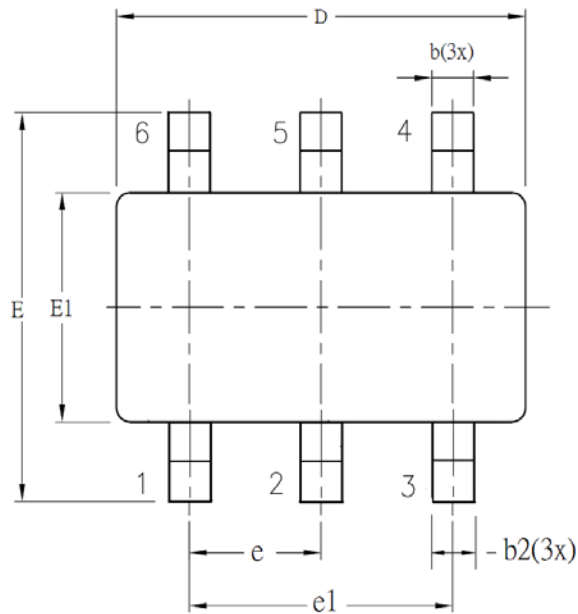

SYM BOL	ALL DIMENSIONS IN MILLIMETERS		
	MINIMUM	NOMINAL	MAXIMUM
A	-	1.30	1.40
A1	0	-	0.15
A2	0.90	1.20	1.30
b	0.30	-	0.50
b1	0.30	0.40	0.45
b2	0.30	0.40	0.50
c	0.08	-	0.22
c1	0.08	0.13	0.20
D	2.90 BSC		
E	2.80 BSC		
E1	1.60 BSC		
e	0.95 BSC		
e1	1.90 BSC		
L	0.30	0.45	0.60
L1	0.60 REF		
L2	0.25 BSC		
R	0.10	-	-
R1	0.10	-	0.25
θ	0°	4°	8°
θ1	5°	-	15°
θ2	5°	-	15°

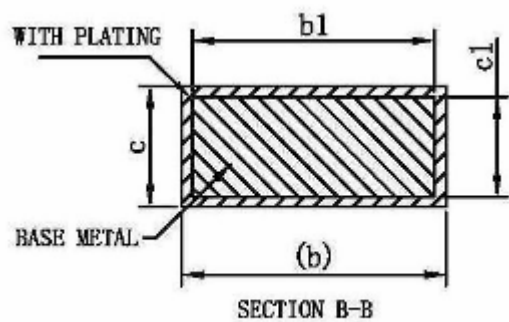
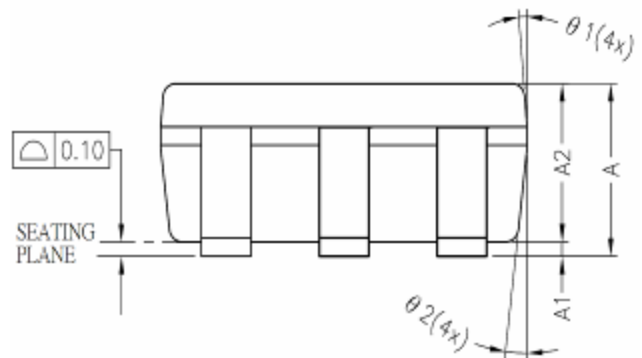

### 13. Tape & Reel Information

#### 13.1. Tape & Reel Information ---SOT-23-6 (Type 1)

Description : Unit: mm ◦

##### 13.1.1. Reel Dimensions

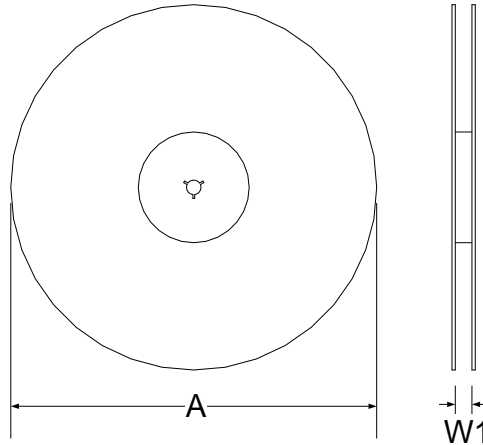

##### 13.1.2. Carrier Tape Dimensions

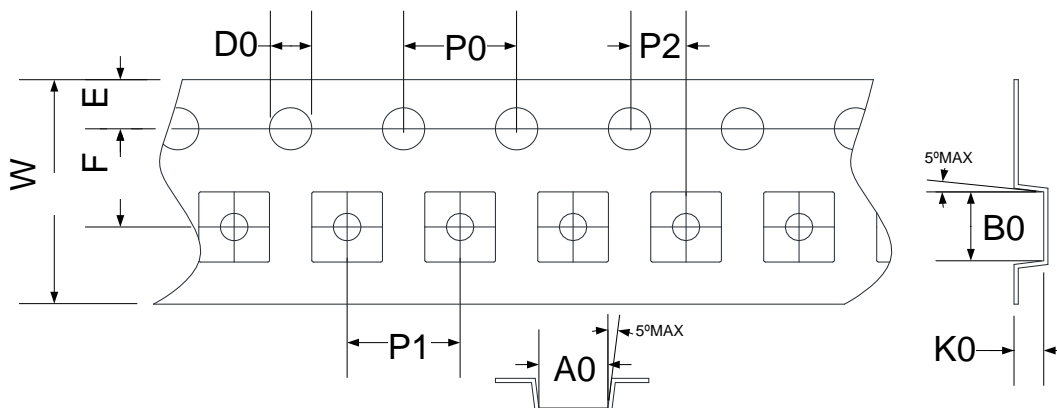

SYMBOLS	Reel Dimensions		Carrier Tape Dimensions									
	A	W1	A0	B0	K0	P0	P1	P2	E	F	D0	W
Spec.	178	9.0	3.30	3.20	1.50	4.00	4.00	2.00	1.75	3.50	1.50	8.00
Tolerance	±0.50	+1.50/-0	±0.10	±0.10	±0.10	±0.10	±0.10	±0.05	±0.10	±0.05	+0.1/-0	±0.20

Note: 10 Sprocket hole pitch cumulative tolerance is ±0.20mm.

##### 13.1.3. PIN1 direction

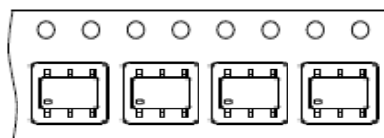

### 13.2. Tape & Reel Information ---SOT-23-6 (Type 2)

Description : Unit: mm ◦

#### 13.2.1. Reel Dimensions

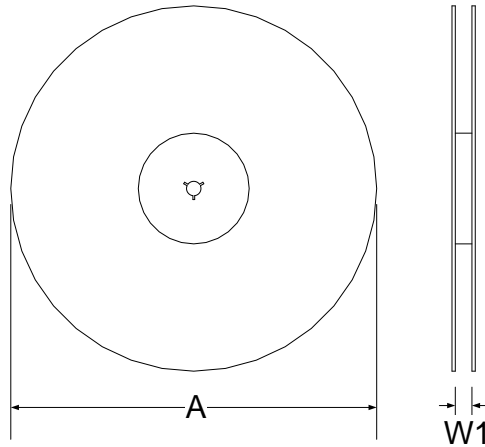

#### 13.2.2. Carrier Tape Dimensions

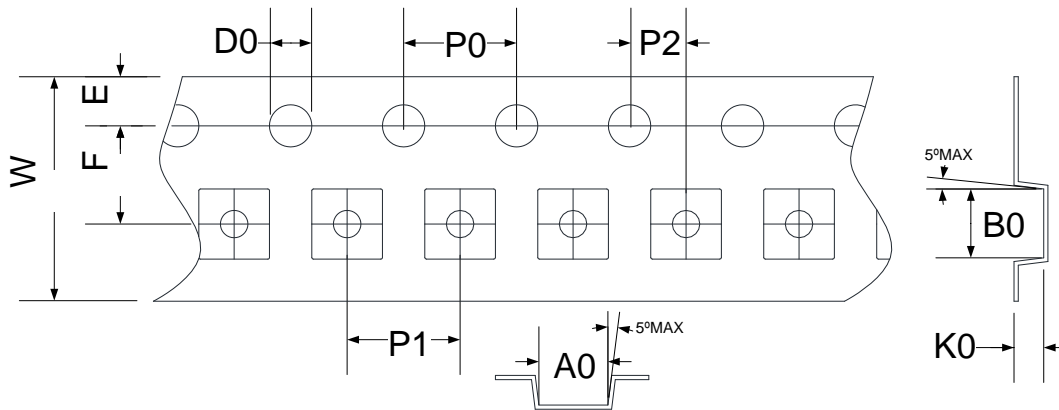

SYMBOLS	Reel Dimensions		Carrier Tape Dimensions										
	A	W1	A0	B0	K0	P0	P1	P2	E	F	D0	W	
Spec.	178	9.4	3.17	3.23	1.37	4.00	4.00	2.00	1.75	3.50	1.55	8.00	
Tolerance	±2.00	±1.50	±0.10	±0.10	±0.10	±0.10	±0.10	±0.10	±0.10	±0.05	±0.05	±0.05	+0.30/-0.10

Note: 10 Sprocket hole pitch cumulative tolerance is ±0.20mm.

#### 13.2.3. PIN1 direction

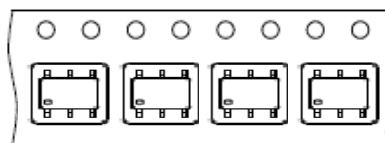

# ZCC2213

## 1 Cell Li Battery Charge Balance IC

---

### 14. Revision History

Major differences are stated thereafter:

---

<b>Version</b>	<b>Page</b>	<b>Revision Summary</b>
V01	-	First Edition
V02	All	Revise Electrical Parameters.
V03	12-13	Add Tape & Reel information.
V04	8	Revise picture of Example Circuit of Battery Charge Balance IC Application.
V05	All	Revise Traceability code.