



Data Sheet

MM32SPIN080C

Arm[®]Cortex[®]-M0 based 32-bit Microcontrollers

Version: Rev1.0

2024/01/02

MindMotion has the right to make any changes and releases to the information contained in this document (including but not limited to specifications and product descriptions) at any time. This document will replace all previously published information.

1 General Introduction

1.1 Overview

MM32SPIN080C is a high-performance 32-bit motion control MCU under MindSPIN. Utilizing Cortex®-M0 as its core, it can operate at a maximum frequency of 60MHz and features built-in 32KB high-speed memory and up to 20 GPIOs. It incorporates a 5V output LDO voltage regulator and three sets of N-channel half-bridge gate drivers. The MCU integrates a 12-bit analog-to-digital converter (ADC), two analog comparators (COMP), two operational amplifiers (OPAMP), one 32-bit general-purpose timer, three 16-bit basic timers, and one 16-bit advanced timer. It also includes a USART interface that can be used for UART or SPI communication.

This product supports a maximum pre-drive voltage of 220V and has an extended operating temperature range of -40°C ~ 105°C. It offers a power-saving mode where the chip consumes around 100uA of energy in sleep mode.

The product is available in QFN48 and QFN32 packages.

With its rich peripheral configurations, this MCU is suitable for a variety of applications:

- Motor driving and application control
- Handheld power tools
- Floor fans
- High-pressure fans
- Vacuum cleaners

1.2 Key features

- Core and system
 - Arm® Cortex®-M0 32-bit MCU
 - Highest operating frequency up to 60MHz
 - Hardware divider (32-bit)
 - 2-channel DMA (Direct Memory Access)
- Memory
 - Up to 32KB Flash program memory
 - Up to 4KB SRAM
 - 3KB independent Flash space available for program or data storage
- Clock, reset, and power management
 - 2.5V ~ 5.5V supply voltage range
 - Power-on/Power down reset (POR/PDR), programmable voltage detector (PVD)
 - Built-in 60MHz high-speed RC oscillator with factory calibration

General Introduction

- 40KHz LSI
- Low power consumption
 - Stop mode with a power consumption of 100uA
- Six timers
 - One 12-bit analog-to-digital converter with a conversion time of 1μS (up to 11 input channels)
 - Conversion range: 0~V_{DD}
 - Ten external channels
 - Supports injection mode
 - Supports multiple data buffer groups
 - Supports configuration of sampling time and resolution
 - On-chip temperature sensor
 - On-chip voltage sensor
- Two analog comparators
- Two rail-to-rail operational amplifiers
- One DMA controller with 2 channels
 - Supported peripherals include Timer, ADC, and USART
- Up to 20 fast I/O ports:
 - All I/O ports can be mapped to 16 external interrupts
 - All ports support V_{DD} signal input/output
- Seven timers
 - One 16-bit 4-channel advanced control timer (TIM1) with 4-channel PWM complimentary outputs and dead zone generation, hardware phase shifting, and brake functions
 - One 32-bit general-purpose timer (TIM2) with up to four input capture/output compare channels
 - Two 16-bit basic timers (TIM3, TIM4) with one input capture/output compare channels
 - One 16-bit timer (TIM6) supporting interrupt triggering
 - One independent watchdog timer
 - One SysTick timer with 24-bit down-counter
- Debug mode
 - Serial Wire Debug (SWD) interface
- 5V LDO voltage regulator
 - Maximum input voltage: 18V
- Three sets of N-type half-bridge gate drivers
 - Operating voltage: 7V~200V
 - Supports voltage UVLO protection
 - 1A/1.2A SINK/SOURCE three-phase gate drive current

General Introduction

- Built-in 200ns dead time setting
- One digital peripheral interface
 - One USART interface supporting UART and SPI communication
- 96-bit unique chip ID (UID)
- Available in QFN48 and QFN32 packages

2 Specification

2.1 Model List

2.1.1 Ordering Information

Table 1 Ordering information

Model		MM32SPIN080C	MM32SPIN080CN
Peripheral			
FLASH memory KB		32	32
SRAM KB		4	4
Timer	General-purpose (32 bit)	1	1
	Basic	3	3
	Advanced	1	1
Communication interface	USART	1	1
Number of GPIO ports		20	17
12-bit ADC	Number	1	1
	Number of channels	11	11
Operational amplifier		2	2
Comparator		2	2
CPU frequency		60 MHz	
Working voltage		7V ~ 18V(Gate Driver、VCC)	7V ~ 18V(Gate Driver、VCC)
Working temperature		-40°C ~ +105°C	-40°C ~ +105°C
Package		QFN48	QFN32

2.1.2 Marking Information

Silkscreen Marking

QFN48 marking sample:



Figure 1 QFN48 package marking

QFN48 packages typically have the following topside marking:

- 1st line: MM32
 - MindMotion
- 2nd line: SPIN080C
 - The product model
- 3rd line: ABCDEFGH
 - Trace code + revision code, where "H" represents chip revision
- 4th line: XZYYWW
 - "XZ" represents the control code.
 - "YYWW" indicates the date code, where "YY" represents the year and "WW" represents the week.

Silkscreen Marking

QFN32 marking sample:

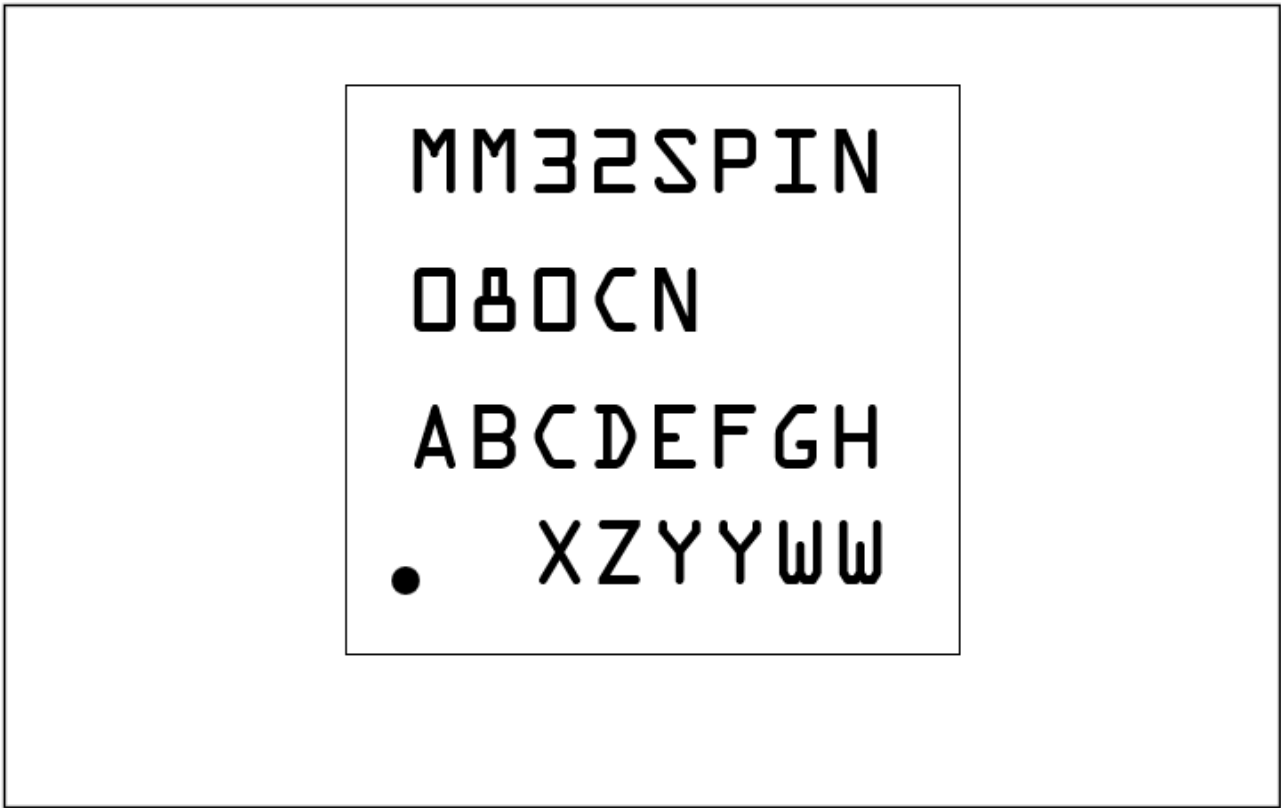

Figure 2 QFN32 package marking

QFN32 package typically has the following topside marking:

- 1st line: MM32SPIN
 - MindMotion SPIN series products
- 2nd line: 080CN
 - The product model
- 3rd line: ABCDEFGH
 - Trace code + revision code, where “H” represents chip revision
- 4th line: XZYYWW
 - “XZ” means Trace code, “YYWW” means Date code, where “YY” indicates the year and “WW” indicates the week

2.1.3 System Block Diagram

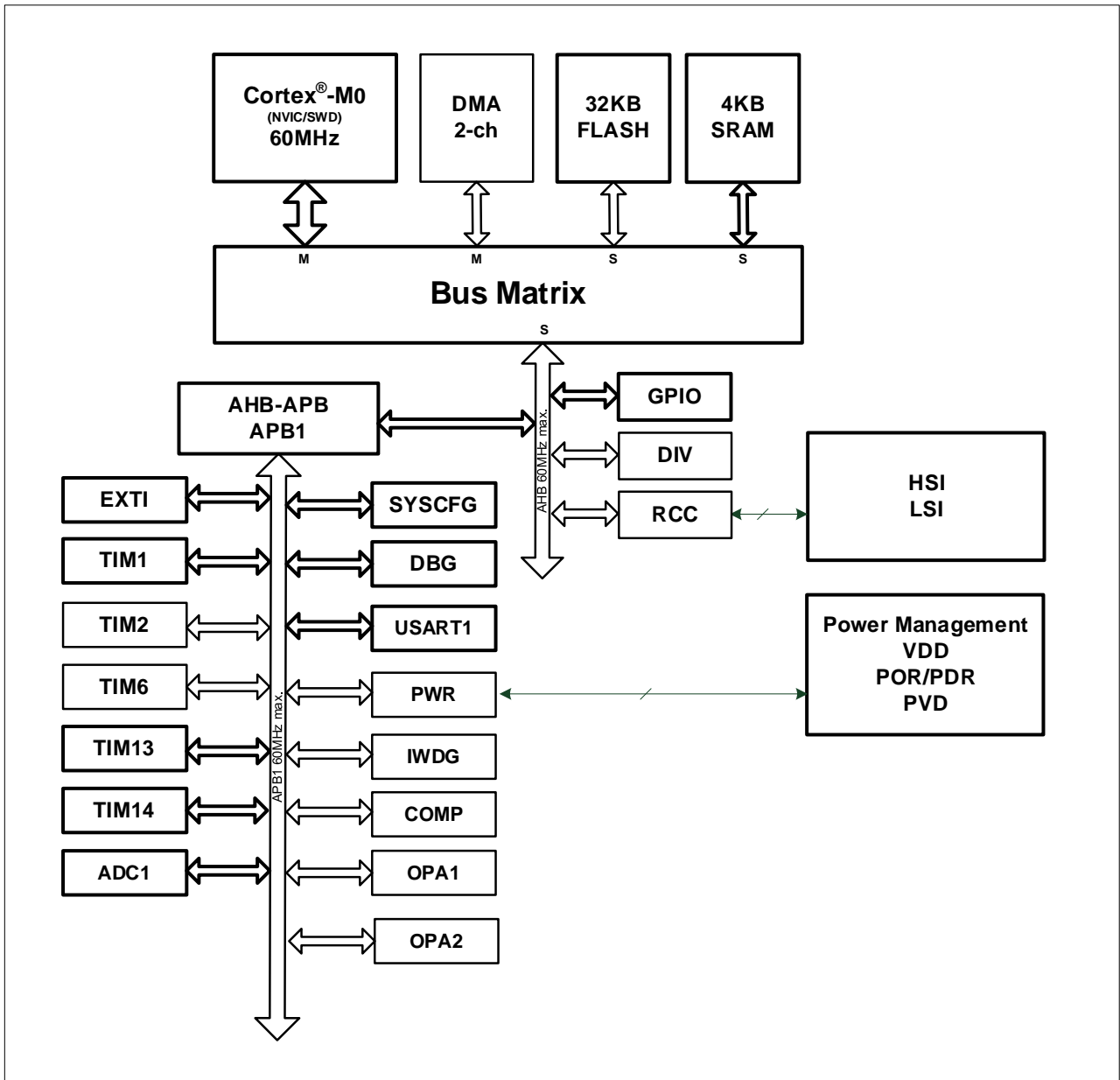

Figure 3 Block diagram

2.2 Functional Description

2.2.1 Core Introduction

The Arm® Cortex-M0 processor is the latest generation of embedded Arm processors, providing a low-cost platform, reduced pin count, and lower system power consumption to meet the needs of MCUs. It offers excellent computational performance and advanced interrupt system response.

This product features a built-in Arm core, making it compatible with all Arm tools and software.

2.2.2 Bus Overview

MM32SPIN080C adopts a matrix bus structure, which includes an AHB interconnect matrix, an AHB bus, and a bridged APB bus.

2.2.3 Memory Map

Table 2 Memory map

	Address Range	Size	Peripheral
Flash	0x0000 0000 - 0x0000 7FFF	32 KB	Can be mapped as main flash memory, data memory, system memory, or SRAM, depending on the configuration of the BOOT.
	0x0000 8000 - 0x07FF FFFF	~127 MB	Reserved
	0x0800 0000 - 0x0800 7FFF	32 KB	Main memory
	0x0800 8000 - 0x1FFD FFFF	~383 MB	Reserved
	0x1FE0 0000 - 0x1FE0 0BFF	3KB	Data memory
	0x1FE0 0C00 - 0x1FFF F3FF	~2MB	Reserved
	0x1FFF F400 - 0x1FFF F7FF	1 KB	System memory
	0x1FFF F800 - 0x1FFF F9FF	0.5KB	Option bytes
SRAM	0x1FFF FA00 - 0x1FFF FFFF	1.5KB	Reserved
	0x2000 0000 - 0x2000 0FFF	4 KB	SRAM
APB1	0x2000 1000 - 0x2FFF FFFF	~255 MB	Reserved
	0x4000 0000 - 0x4000 03FF	1KB	TIM2
	0x4000 0400 - 0x4000 0FFF	3KB	Reserved
	0x4000 1000 - 0x4000 13FF	1KB	TIM6
	0x4000 1400 - 0x4000 17FF	1KB	Reserved
	0x4000 1800 - 0x4000 1BFF	1KB	TIM13
	0x4000 1C00 - 0x4000 2FFF	5KB	Reserved
	0x4000 3000 - 0x4000 33FF	1KB	IWDG
	0x4000 3400 - 0x4000 6FFF	15KB	Reserved
	0x4000 7000 - 0x4000 73FF	1KB	PWR
	0x4000 7400 - 0x4000 8FFF	7KB	Reserved
	0x4000 9000 - 0x4000 93FF	1KB	OPA1
	0x4000 9400 - 0x4000 97FF	1KB	OPA2
	0x4000 9800 - 0x4000 FFFF	26KB	Reserved
	0x4001 0000 - 0x4001 03FF	1KB	SYSCFG
	0x4001 0400 - 0x4001 07FF	1KB	EXTI
	0x4001 0800 - 0x4001 0BFF	1KB	Reserved
	0x4001 0C00 - 0x4001 0FFF	1KB	USART1
	0x4001 1000 - 0x4001 23FF	5KB	Reserved
	0x4001 2400 - 0x4001 27FF	1KB	ADC1
	0x4001 2800 - 0x4001 2BFF	1KB	Reserved
	0x4001 2C00 - 0x4001 2FFF	1KB	TIM1
	0x4001 3000 - 0x4001 33FF	1KB	Reserved
	0x4001 3400 - 0x4001 37FF	1KB	DBG
	0x4001 3800 - 0x4001 3BFF	1KB	Reserved
	0x4001 3C00 - 0x4001 3FFF	1KB	COMP
	0x4001 4000 - 0x4001 43FF	1KB	TIM14
	0x4001 4400 - 0x4001 FFFF	47KB	Reserved
AHB	0x4002 0000 - 0x4002 03FF	1KB	DMA
	0x4002 0400 - 0x4002 0FFF	3KB	Reserved
	0x4002 1000 - 0x4002 13FF	1KB	RCC
	0x4002 1400 - 0x4002 1FFF	3KB	Reserved
	0x4002 2000 - 0x4002 23FF	1KB	Flash Interface

	Address Range	Size	Peripheral
	0x4002 2400 – 0x4002 FFFF	55KB	Reserved
	0x4003 0000 – 0x4003 03FF	1KB	HWDIV
	0x4003 0400 – 0x47FF FFFF	~128MB	Reserved
	0x4800 0000 – 0x4800 03FF	1KB	PORT A
	0x4800 0400 – 0x4800 07FF	1KB	PORT B

2.2.4 Built-in Flash

Built-in 32KB + 3KB Flash for storing programs and data.

2.2.5 Built-in SRAM

Built-in 4KB SRAM.

2.2.6 Nested Vectored Interrupt Controller (NVIC)

This product features a built-in Nested Vectored Interrupt Controller, capable of handling multiple maskable interrupt channels (excluding the 16 Cortex®-M0 interrupt lines) and 4 programmable priorities.

- Tightly-coupled NVIC for low-latency interrupt response handling
- Interrupt vector entry addresses directly into the core
- Allows early processing of interrupts
- Handles late-arriving higher-priority interrupts
- Supports tail-chaining of interrupts
- Automatically saves processor state
- Automatic restoration upon interrupt return, without additional instruction

This module provides flexible interrupt management with minimal interrupt latency.

2.2.7 External Interrupt/Event Controller (EXTI)

The External Interrupt/Event Controller includes multiple edge detectors used to capture level changes from the IO pins and generate interrupt/event requests. All IO pins can be connected to 16 external interrupt lines. Each interrupt line can be independently enabled or disabled and configured with its own trigger mode (rising edge, falling edge, or both edges). A pending status register maintains the status of all interrupt requests.

EXTI can detect level changes with a pulse width shorter than the internal AHB bus clock cycle.

2.2.8 Clock and Boot

The system clock is selected after chip startup. Upon reset, the internal 60 MHz oscillator is used as the default system clock, and the system clock is configured with an 8-divider. The system clock divider configuration can be changed to increase the system frequency (taking into account the wait control for Flash access).

In the clock system, multiple prescalers are used to generate clocks for the AHB bus and high-speed APB1 bus. The clock frequency for the AHB and high-speed APB buses can reach up to 60 MHz. The clock tree of the clock system is illustrated in the figure below.

Specification

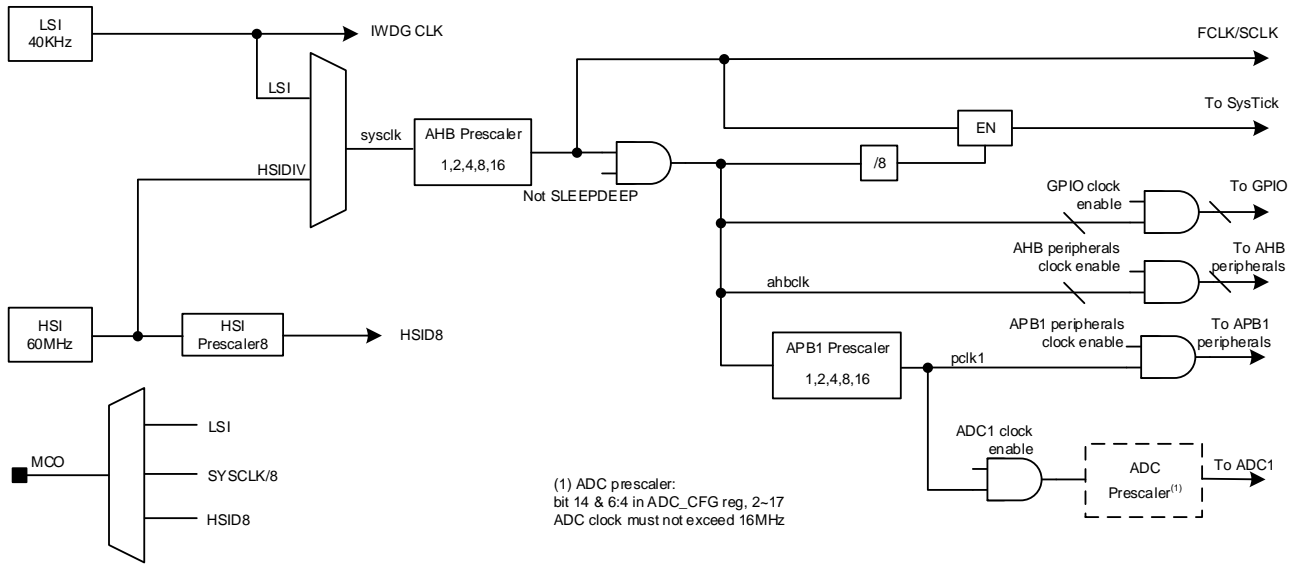

Figure 4 Clock tree

2.2.9 Boot Modes

During startup, one of four boot modes can be selected using the BOOT0 pin and the BOOT0SEL bit:

- Boot from the program memory
- Boot from the system memory
- Boot from the data memory
- Boot from the internal SRAM

The bootloader is located in the system memory and can be programmed via a serial interface, such as USART1.

2.2.10 Power Supply Schemes

$V_{DD} = 2.5V \sim 5.5V$: The I/O pins and internal regulators are powered through the V_{DD} pin. It provides power to the ADC, reset module, and oscillator.

2.2.11 Power Supply Supervisors

The product incorporates an internal power on reset (POR)/power down reset (PDR) circuit that is always active and ensures proper operation when the system voltage exceeds 2.5V. When V_{DD} drops below the set threshold (V_{POR}/V_{PDR}), the device is held in a reset state.

The device also includes a programmable voltage detector (PVD) that monitors the V_{DD} supply and compares it to the threshold voltage (V_{PVD}). When V_{DD} goes below or above the threshold, an interrupt is generated, and the interrupt handler can issue warning messages or transition the microcontroller into a safe mode. The PVD function needs to be enabled through software.

2.2.12 Voltage Regulator

The on-chip voltage regulator converts the external voltage to the operating voltage for the internal circuitry. The voltage regulator remains active after the chip is reset.

2.2.13 Low-Power Mode

The product supports low-power mode, which can achieve the optimal balance between low power consumption and fast startup.

Table 3 Low-power mode list

Mode	Entry	Wake-up	Impact on 1.5V domain clock	Impact on VDD area clock	Voltage regulator	Impact on data and registers	Notes
Sleep Mode	WFI (Wait for Interrupt)	Any interrupt	CPU clock off, no influence on other clocks and ADC clock	No	On		Peripheral clocks continue, contents of registers and SRAM retained
	WFE (Wait for Event)	Wake-up event					
Stop Mode	Set SLEEPDEEP bit; WFI or WFE	Any external interrupt (configured in external interrupt registers) or	All clocks operating in the 1.5V domain are off	HSI off	On	Contents of registers and SRAM retained	GPIOs not used before entering low-power mode

Mode	Entry	Wake-up	Impact on 1.5V domain clock	Impact on VDD area clock	Voltage regulator	Impact on data and registers	Notes
		event, IWDG interrupt (non-reset)					should be set to analog input state

Sleep Mode

In Sleep Mode, the CPU is stopped, but all peripherals, including CPU peripherals such as NVIC and SysTick, continue to operate.

Stop Mode

Stop Mode achieves lower power consumption while preserving the contents of SRAM and registers. In Stop Mode, HSI is turned off. The microcontroller can be woken up from Stop Mode by any signal configured as EXTI, which can be one of the 16 external I/O pins or the wake-up signal from the PVD.

2.2.14 Hardware Divider (HWDIV)

The built-in hardware divider unit automatically performs signed or unsigned 32-bit integer division operations. Hardware division is particularly useful in high-performance applications.

2.2.15 Direct Memory Access Controller (DMA)

The flexible 2-channel general-purpose DMA manages data transfers between memory to memory, device to memory, and memory to device. The DMA controller supports circular buffer management, avoiding interrupts when the controller reaches the end of the buffer.

Each channel has dedicated hardware DMA request logic and can also be triggered by software. The length of the transfer, source address, and destination address can all be set separately by software.

DMA can be used with major peripherals such as USART, ADC, and general/basic/advanced control timers TIMx.

2.2.16 Timers and Watchdog (TIMs & WDG)

The product includes 1 advanced control timer, 1 general-purpose timer, and 3 basic timers, as well as 1 watchdog timer and 1 SysTick timer. The following table compares the features of the advanced control timer, general-purpose timer, and basic timers:

Table 4 Timer function comparison

Timer type	Name	Counter resolution	Counter type	Prescaler factor	DMA request generation	Capture/compare channel	Complementary output
Advanced	TIM1	16-bit	up, down, up/down	Any integer between 1 and 65536	Yes	No/4	Yes

Specification

General-purpose	TIM2	32-bit	up, down, up/down	Any integer between 1 and 65536	Yes	4/4	No
Basic	TIM6	16-bit	up	Any integer between 1 and 65536	Yes	No	No
	TIM13/14	16-bit	up	Any integer between 1 and 65536	Yes	1/1	No

Advanced control timer (TIM1)

The advanced control timer consists of a 16-bit counter, 4 compare channels, and a three-phase complementary PWM generator. It provides complementary PWM outputs with dead-time insertion and can also be used as a full-featured general-purpose timer. The four independent channels can be used for:

- Output comparison
- PWM generation (edge or center-aligned mode)
- Single-pulse output

When configured as a 16-bit general-purpose timer, it has the same functionality as the TIM2 timer. When configured as a 16-bit PWM generator, it has full modulation capability (0 ~ 100%).

In debug mode, the counter can be frozen, and PWM output can be disabled, cutting off the switches controlled by these outputs.

Many features are the same as those of general-purpose timer, and the internal structure is also the same. Therefore, the advanced control timer can be used in conjunction with the general-purpose timer via timer chaining feature to provide synchronization or event chaining functionality.

32-bit general-purpose timer (TIM2)

The product has a built-in general-purpose timer (TIM2) that can run synchronously. The timer features a 32-bit auto-reload up/down counter, a 16-bit prescaler, and 4 independent channels. Each channel can be used for input capture, output compare, PWM, and single-pulse mode output.

Basic timer (TIM6)

The basic timer is based on a 16-bit programmable prescaler and a 16-bit auto-reload counter. It provides a convenient counting and timing function, and the counter clock signal is obtained by dividing the clock source with a prescaler.

Basic timer (TIM13/14)

The basic timers are based on a 16-bit programmable prescaler and a 16-bit auto-reload

counter. The counter clock signal is obtained by dividing the clock source with a prescaler. TIM13/14 have multiple uses, such as input functions (measuring pulse width, frequency, etc. of input signals) and output functions (PWM output, comparison output, etc.).

Independent watchdog (IWDG)

The independent watchdog is based on a 12-bit downcounter and an 8-bit prescaler. It is clocked by an internal independent 40kHz oscillator. This oscillator runs independently of the main clock and can operate in all operating modes. The IWDG can be used to reset the entire system when a problem occurs or as a free-running timer for timeout management in applications. It can be configured as a software or hardware startup watchdog through option bytes. In debug mode, the counter can be frozen.

SysTick timer (SysTick)

This timer is dedicated to real-time operating systems but can also be used as a standard downcounter. It has the following features:

- 24-bit downcounter
- Auto-reload feature
- Generates a maskable interrupt when the counter reaches 0
- Programmable clock source

2.2.17 General Purpose Input/Output (GPIO)

Each GPIO pin can be configured by software as an output (push-pull or open-drain), an input (with or without, pull-up or pull-down), or a multiplexed peripheral function port. Most GPIO pins are shared with digital or analog multiplexed peripherals.

In case of need, the peripheral function of an I/O pin can be locked through a specific operation to prevent accidental writes to the I/O registers.

2.2.18 Universal Synchronous/Asynchronous Receiver/Transmitter (USART)

The USART supports asynchronous mode (UART) and synchronous mode. The UART supports single-wire half-duplex communication, and both UART and synchronous modes support modem control operations (CTS/RTS hardware automatic flow control).

The USART interface supports DMA operations and can achieve data communication with SPI in synchronous mode.

2.2.19 Analog-to-Digital Converter (ADC)

The product has a built-in 12-bit analog-to-digital converter (ADC) with 10 available external channels. It can perform single, single-cycle, and continuous scan conversions. In scan mode, it automatically converts the values in a selected set of analog input. The ADC supports DMA operations.

The analog watchdog feature allows precise monitoring of one or all selected channels. An interrupt is generated when the monitored signal exceeds a predefined threshold.

Events generated by timers (TIMx) can be connected to the trigger input of the ADC, allowing configuration of ADC conversions synchronized with the clock.

Temperature Sensor

The temperature sensor generates a voltage that varies linearly with temperature and can be connected internally to an ADC input channel.

2.2.20 Analog Comparator (COMP)

The product is embedded with two comparators that can be used independently or in combination with a timer. The COMP module can be utilized for various functions, including:

- Triggering low-power mode wakeup events by analog signals
- Supporting window control function to suppress current overshoot glitches generated when PWM is turned on
- Combining with PWM output from a timer to form a per-cycle current control loop
- Each comparator has selectable thresholds
- The internal 8-bit CRV (Comparison Reference Voltage) can be selected as V_{DD} or a voltage value divided from the internal reference voltage
- Programmable hysteresis voltage
- Implementing Cyclic polling function with fixed periods
- Programmable speed and power consumption
- The output can be redirected to an I/O port or multiple timer input ports, triggering the following events:
 - Capture events
 - OCref_clr events (per-cycle current control)
- Supporting brake events for fast PWM shutdown.

2.2.21 Operational Amplifier (OPAMP)

The chip is embedded with two operational amplifiers, and the input and output of each operational amplifier are connected to I/O, allowing them to be connected with ADC and comparators through shared I/O. Rail-to-rail input/output are also supported.

2.2.22 Serial Wire Debug (SWD)

Embedded with the Arm-standard two-wire serial debugging interface (SW-DP).

3 Pin Definition and Alternate Function

3.1 Pinout Diagram

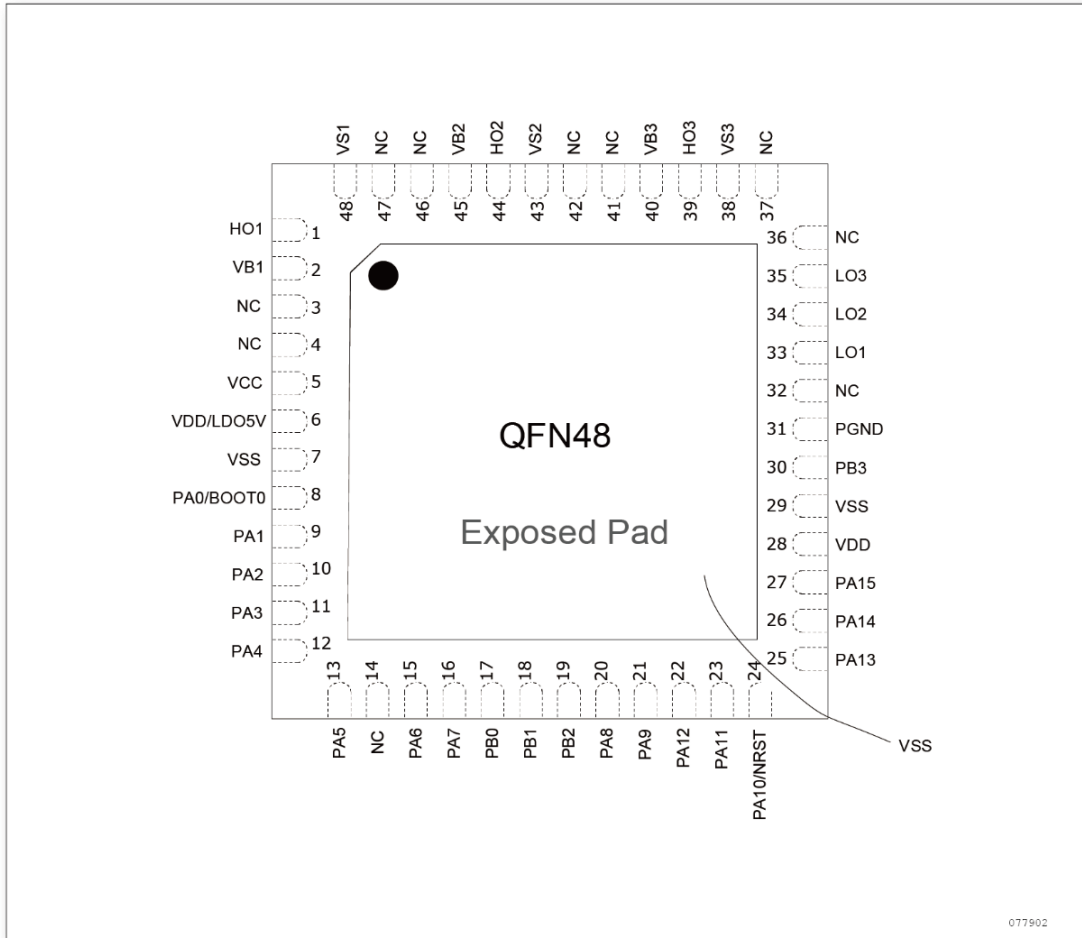

Figure 5 QFN48 pinout diagram

Pin Definition and Alternate Function

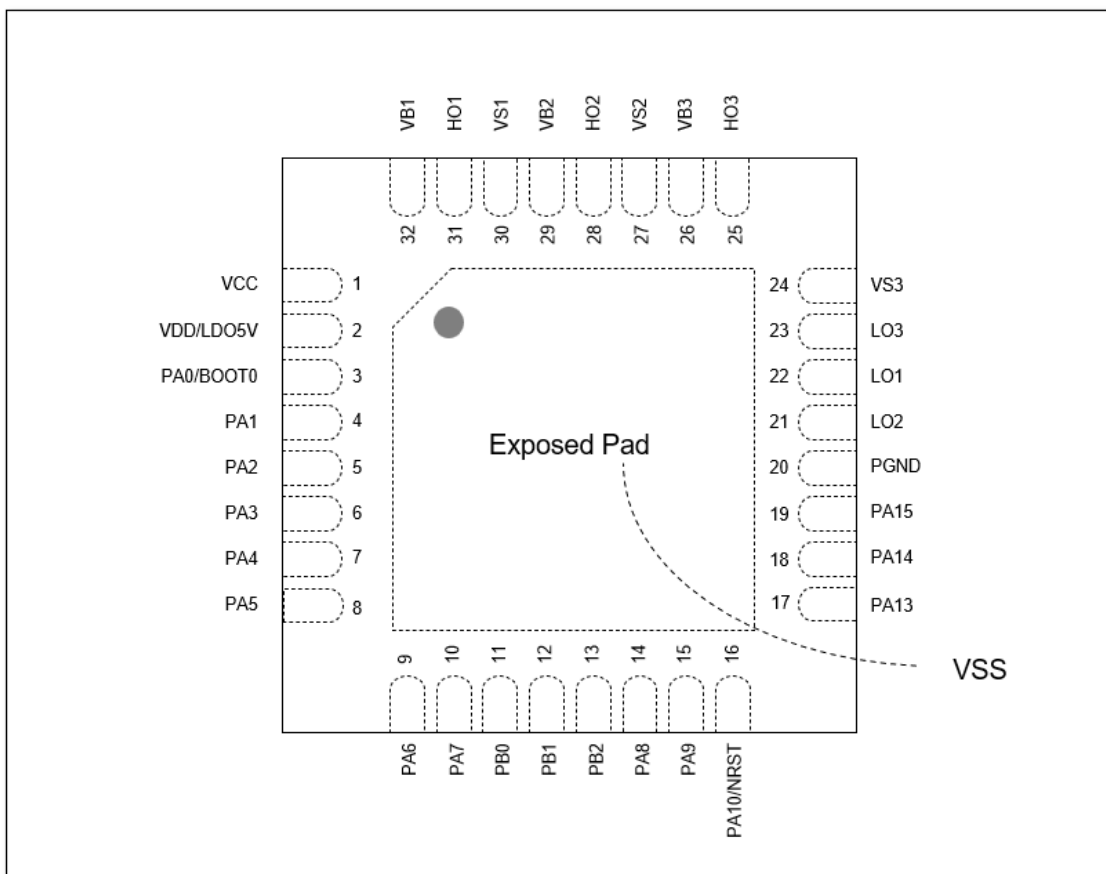

Figure 6 QFN32 pinout diagram

3.2 Pin Assignment Table

Table 5 Pin assignment table

Pin ID		Name	Type (1)	I/O level (2)	Main Function	Alternate function	Additional function TSSOP28
TSSOP28	QFN28						
1	31	HO1	-	-	HO1	-	-
2	32	VB1	-	-	VB1	-	-
3	-	NC	-	-	NC	-	-
4	-	NC	-	-	NC	-	-
5	1	VCC	-	-	VCC	-	-
6	2	LDO5V/VDD	-	-	LDO5V/VDD	-	-
7		VSS	-	-	VSS	-	-
8	3	PA0/BOOT0	I/O	TC	PA0	TIM2_CH1 TIM13_CH1 TIM1_BKIN4 USART1_SCLK ADC_TRIG_O	BOOT0
9	4	PA1	I/O	TC	PA1	TIM2_ETR TIM13_CH1 TIM2_CH2 USART1_TX COMP1_OUT	ADC_IN0
10	5	PA2	I/O	TC	PA2	TIM2_ETR TIM14_CH1 TIM1_ETR TIM1_BKIN5 USART1_RX COMP2_OUT	ADC_IN1
11	6	PA3	I/O	TC	PA3	TIM2_CH1 TIM13_CH1 USART1_nCTS	ADC_IN2 COMP1_INP[0] OPA2_IN+
12	7	PA4	I/O	TC	PA4	TIM2_CH2 TIM14_CH1 USART1_nRTS	ADC_IN3 COMP1_INM[0]/COMP2_INM[0] OPA2_IN-
13	8	PA5	I/O	TC	PA5	TIM2_CH3 TIM14_CH1 TIM1_ETR TIM1_BKIN6	ADC_IN4 COMP1_INP[1] OPA2_OUT
14		NC	-	-	NC		
15	9	PA6	I/O	TC	PA6	TIM2_CH1 TIM13_CH1	COMP1_INP[2] OPA1_IN+
16	10	PA7	I/O	TC	PA7	TIM2_CH2 TIM14_CH1 MCO USART1_nCTS	COMP2_INM[1]/COMP1_INM[1] OPA1_IN-
17	11	PB0	I/O	TC	PB0	TIM2_CH3 TIM13_CH1 USART1_nRTS	ADC_IN5 COMP2_INP[0]/COMP1_INP[3] OPA1_OUT
18	12	PB1	I/O	TC	PB1	TIM2_CH4 TIM14_CH1 USART1_RX USART1_TX	ADC_IN6 COMP2_INM[2]
19	13	PB2	I/O	TC	PB2	TIM2_CH3 TIM13_CH1 TIM1_BKIN7 USART1_SCLK	ADC_IN7 COMP2_INP[1]
20	14	PA8	I/O	TC	PA8	TIM2_CH2 TIM14_CH1 MCO USART1_TX	ADC_IN8 COMP2_INP[2]/COMP1_INM[2]

Pin Definition and Alternate Function

Pin ID		Name	Type (1)	I/O level (2)	Main Function	Alternate function	Additional function TSSOP28
TSSOP28	QFN28						
21	15	PA9	I/O	TC	PA9	TIM2_CH1 TIM13_CH1 USART1_RX	ADC_IN9 COMP2_INP[3]
22		PA12	I/O	TC	PA12	TIM2_ETR TIM1_BKIN1 TIM14_CH1 USART1_RX ADC_TRIG_O COMP2_OUT	-
23		PA11	I/O	TC	PA11	TIM2_ETR ADC_TRIG_O TIM1_ETR TIM13_CH1 USART1_TX TIM2_CH1 COMP1_OUT	-
24	16	PA10/NRST	I/O	TC	PA10		-
25	17	PA13	I/O	TC	PA13	SWDIO TIM13_CH1 USART1_SCLK USART1_RX COMP1_OUT	-
26	18	PA14	I/O	TC	PA14	SWDCLK TIM14_CH1 USART1_nRTS USART1_TX COMP2_OUT	-
27	19	PA15	I/O	TC	PA15	TIM1_CH4N TIM1_CH3 TIM1_CH4 TIM1_CH1N TIM1_CH1 TIM1_CH3N TIM13_CH1 TIM14_CH1	-
28		VDD	S	-	VDD	-	-
29		VSS	S	-	VSS	-	-
30		PB3	I/O	TC	PB3	TIM1_CH4 TIM1_CH2 TIM1_CH1 TIM1_CH2N TIM1_CH1N TIM1_BKIN2 TIM1_CH3N TIM1_CH3	-
31	20	PGND	-	-	PGND	-	-
32		NC	-	-	NC		
33	22	LO1			LO1		
34	21	LO2			LO2		
35	23	LO3			LO3		
36		NC	-	-	NC		
37		NC	-	-	NC		
38	24	VS3			VS3		
39	25	HO3			HO3		
40	26	VB3			VB3		
41		NC	-	-	NC		
42		NC	-	-	NC		
43	27	VS2			VS2		

Pin Definition and Alternate Function

Pin ID		Name	Type (1)	I/O level (2)	Main Function	Alternate function	Additional function TSSOP28
TSSOP28	QFN28						
44	28	HO2			HO2		
45	29	VB2			VB2		
46		NC	-	-	NC		
47		NC	-	-	NC		
48	30	VS1			VS1		

1) I = input, O = output, S = power pins, HiZ = high resistance

2) TC: standard IO, input signal level should not exceed VDD

3.3 Multiplex Function Table

Table 6 Multiplex function for PA port AF0-AF7

Pin Name	AF0	AF1	AF2	AF3	AF4	AF5	AF6	AF7
PA1	TIM2_ETR		TIM13_CH1	TIM2_CH2			USART1_TX	COMP1_OUT
PA2	TIM2_ETR		TIM14_CH1		TIM1_ETR	TIM1_BKIN5	USART1_RX	COMP2_OUT
PA3	TIM2_CH1		TIM13_CH1				USART1_nCTS	
PA4	TIM2_CH2		TIM14_CH1				USART1_nRTS	
PA5	TIM2_CH3		TIM14_CH1		TIM1_ETR	TIM1_BKIN6		
PA6	TIM2_CH1			TIM13_CH1				
PA7	TIM2_CH2			TIM14_CH1	MCO		USART1_nCTS	
PA8	TIM2_CH2		TIM14_CH1		MCO		USART1_TX	
PA9	TIM2_CH1		TIM13_CH1				USART1_RX	
PA10/NRST								-
PA11	TIM2_ETR	ADC_TRIG_O	TIM1_ETR	TIM13_CH1		USART1_TX	TIM2_CH1	COMP1_OUT
PA12	TIM2_ETR		TIM1_BKIN1	TIM14_CH1		USART1_RX	ADC_TRIG_O	COMP2_OUT
PA13	SWDIO			TIM13_CH1		USART1_SCLK	USART1_RX	COMP1_OUT
PA14	SWDCLK			TIM14_CH1		USART1_nRTS	USART1_TX	COMP2_OUT
PA15	TIM1_CH4N	TIM1_CH3	TIM1_CH4	TIM1_CH1N	TIM1_CH1	TIM1_CH3N	TIM13_CH1	TIM14_CH1

Table 7 Multiplex function for PB port AF0-AF7

Pin Name	AF0	AF1	AF2	AF3	AF4	AF5	AF6	AF7
PB0	TIM2_CH3			TIM13_CH1			USART1_nRTS	
PB1	TIM2_CH4			TIM14_CH1			USART1_RX	USART1_TX
PB2	TIM2_CH3		TIM13_CH1			TIM1_BKIN7	USART1_SCLK	
PB3	TIM1_CH4	TIM1_CH2	TIM1_CH1	TIM1_CH2N	TIM1_CH1N	TIM1_BKIN2	TIM1_CH3N	TIM1_CH3
PB4	TIM1_CH3N	TIM1_CH3	TIM1_CH1N	TIM1_CH1	TIM1_CH2	TIM1_CH4N	TIM1_CH4	TIM1_CH2N
PB5	TIM1_CH3	TIM1_CH4	TIM1_CH1N	TIM1_CH1	TIM1_CH2N	TIM1_CH4N	TIM1_CH3N	TIM1_CH2
PB6	TIM1_CH2N	TIM1_CH1N	TIM1_CH3N	TIM1_CH4	TIM1_CH3	TIM1_CH2	TIM1_CH1	TIM1_CH4N
PB7	TIM1_CH2	TIM1_CH2N	TIM1_CH4	TIM1_CH3	TIM1_CH3N	TIM1_CH1	TIM1_CH1N	TIM1_CH4N
PB8	TIM1_CH1N	TIM1_CH3N	TIM1_CH3	TIM1_CH2	TIM1_CH1	TIM1_BKIN3	TIM13_CH1	TIM1_CH2N
PB9	TIM1_CH1	TIM1_CH1N	TIM1_CH3N	TIM1_CH4	TIM1_CH4N	TIM1_CH3	TIM14_CH1	TIM1_CH2

Pin Definition and Alternate Function

Table 8 IO ports used by comparators

	INP0	INP1	INP2	INP3	INM0	INM1	INM2	OUT
COMP1	PA3	PA5	PA6	PB0	PA4	PA7	PA8	PA1/PA11/PA13
COMP2	PB0	PB2	PA8	PA9	PA4	PA7	PB1	PA2/PA12/PA14

Table 9 IO ports used by OPs

	INP	INM	OUT
OP1	PA6	PA7	PB0
OP2	PA3	PA4	PA5

3.4 Driver Chip Expansion Pin Description

Table 10 Gate driver pin description

Pin Code		Name	Function
QFN48	QFN32		
1	31	HO1	Gate driver upper bridge arm output 1, its input corresponds to PB9.
2	32	VB1	Gate driver bootstrap power supply output 1.
5	1	VCC	Gate driver internal power supply. This pin is the input for the internal LDO's 12V voltage.
6	2	LDO5V/VDD	IC internal MCU power supply. This pin is the output of the internal LDO's 5V voltage.
7		VSS	Ground wire of the IC
31	20	PGND	GateDriver's GND
33	22	LO1	Gate driver lower bridge arm output 1, its input corresponds to PB6.
34	21	LO2	Gate driver lower bridge arm output 2, its input corresponds to PB5.
35	23	LO3	Gate driver lower bridge arm output 3, its input corresponds to PB4.
38	24	VS3	Power switching circuit output phase node 3.
39	25	HO3	Gate driver upper bridge arm output 3, its input corresponds to PB7.
40	26	VB3	Gate driver bootstrap power supply output 3.
43	27	VS2	Power switching circuit output phase node 2.
44	28	HO2	Gate driver upper bridge arm output 2, its input corresponds to PB8.
45	29	VB2	Gate driver bootstrap power supply output 2.
48	30	VS1	Power switching circuit output phase node 1.

3.5 Functional Block Diagram and Application Reference Circuit

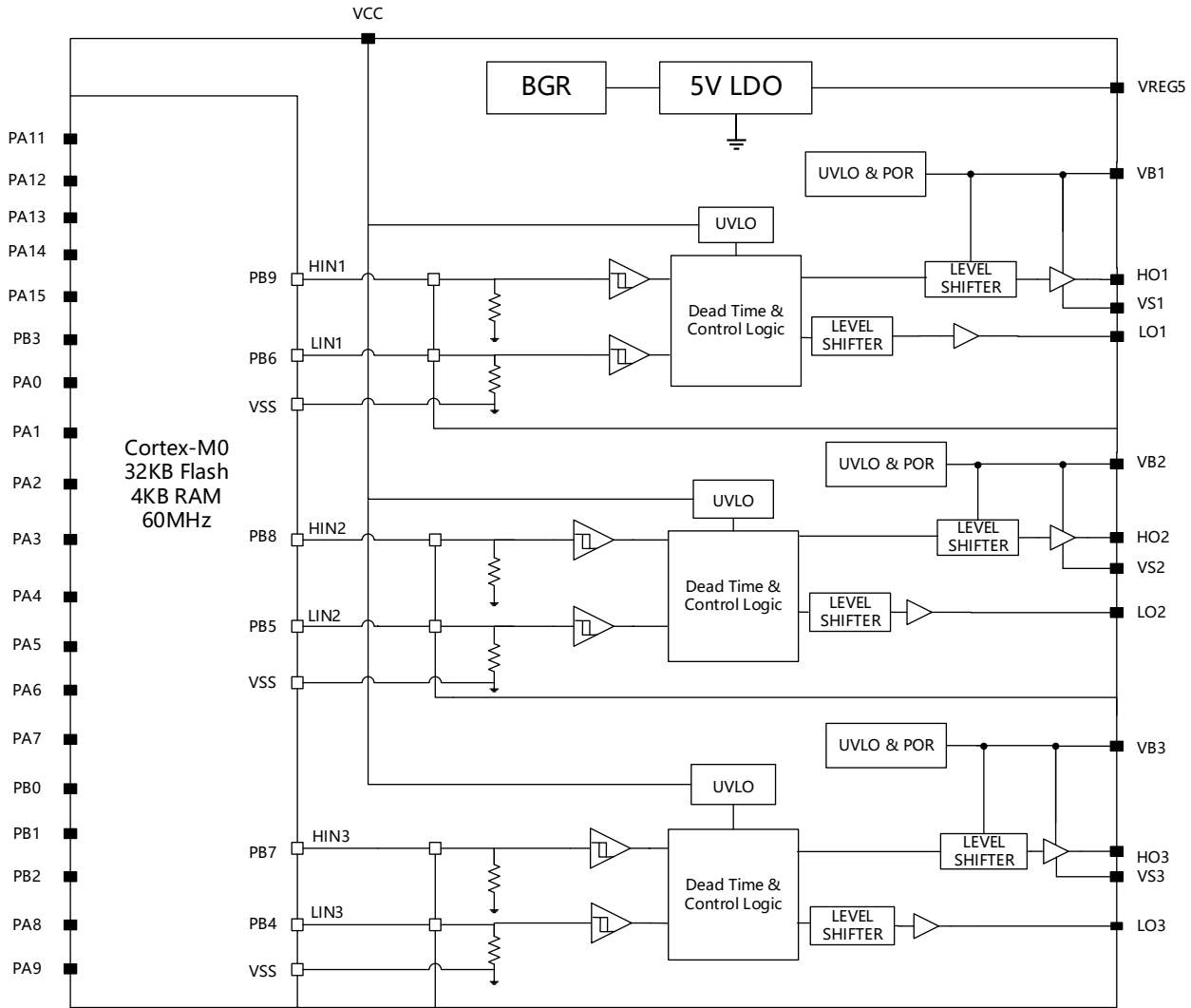

Figure 7 Functional block diagram and application reference circuit

4 Electrical Characteristics

4.1 Test Condition

Unless otherwise specified, all voltages are referenced to VSS.

4.1.1 Load Capacitor

The loading conditions used for pin parameter measurement are shown in the figure below.

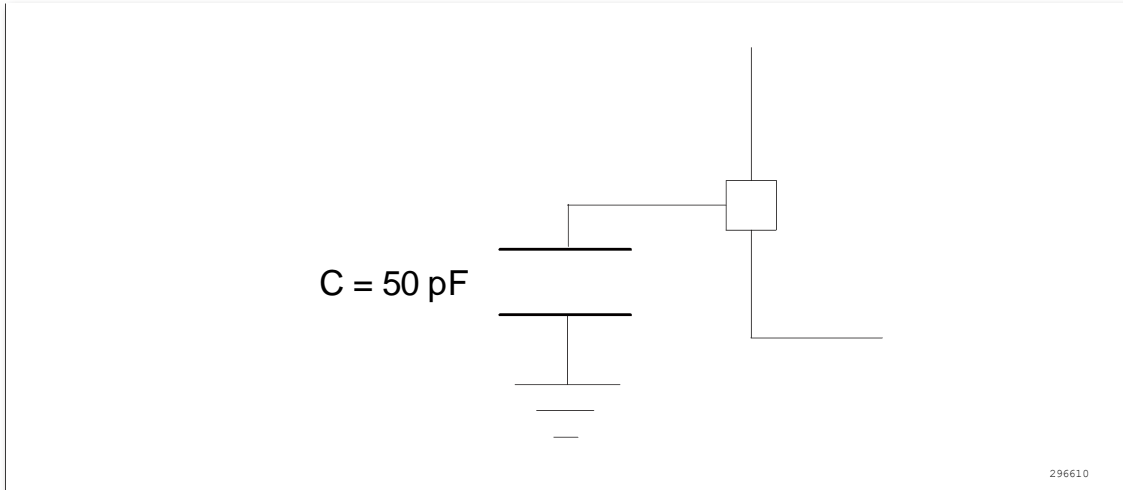

Figure 8 Pin loading conditions

4.1.2 Pin Input Voltage

The measurement method for pin input voltage is shown in the figure below.

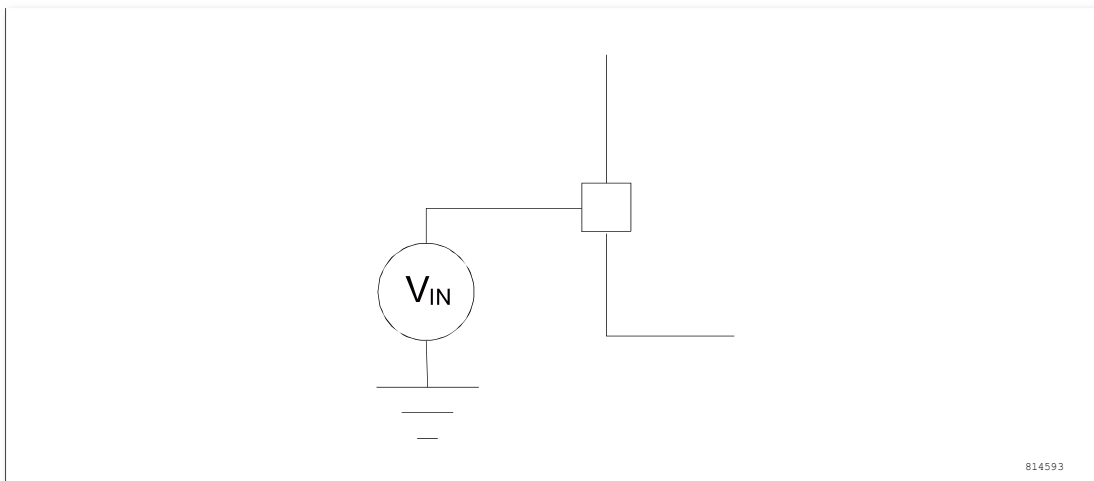

Figure 9 Pin input voltage

4.1.3 Power Scheme

The power scheme is shown in the figure below.

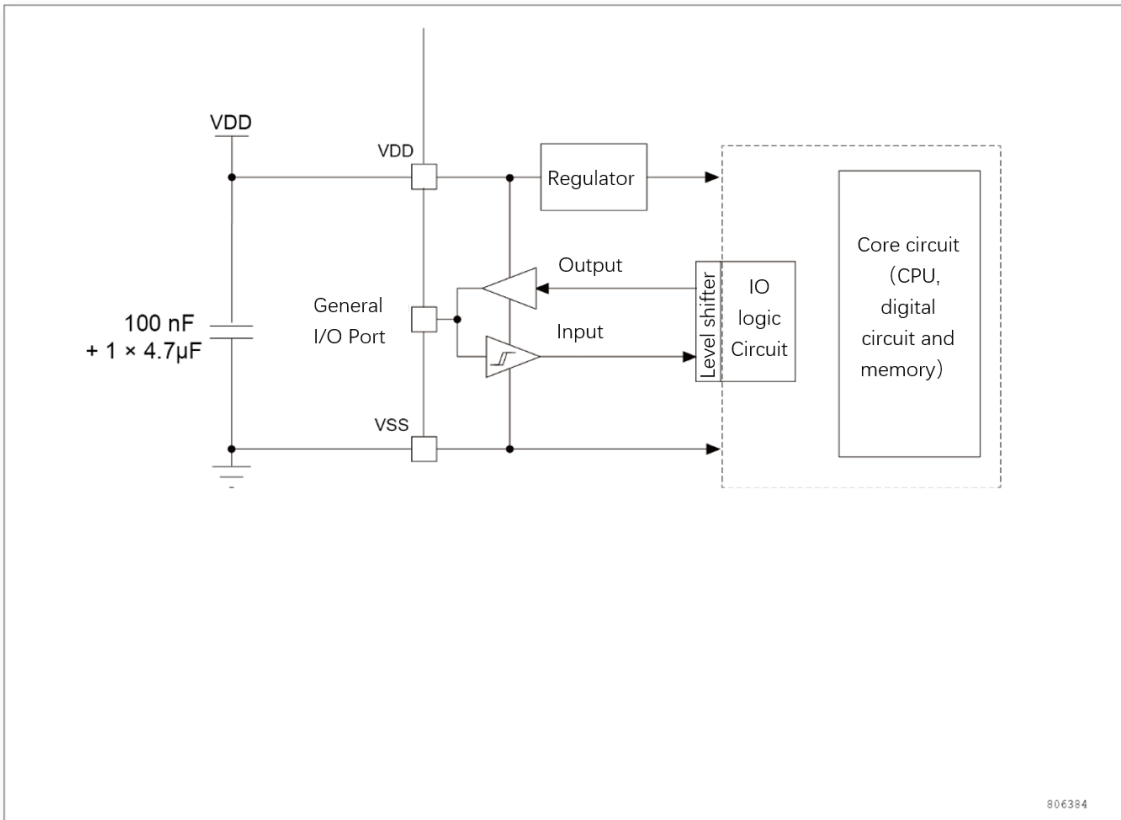

Figure 10 Scheme of power supply

4.1.4 Current Consumption Measurement

The measurement method for current consumption on pins is shown in the figure below.

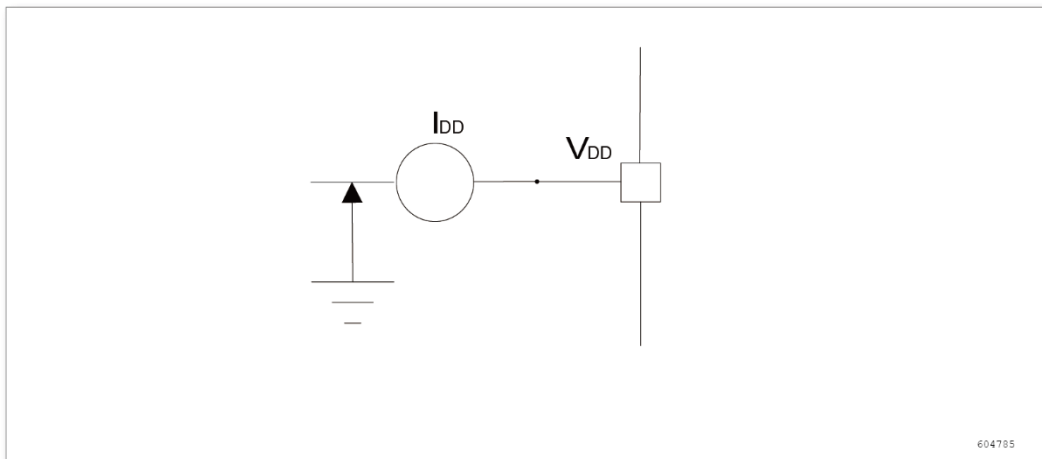

Figure 11 Current consumption measurement scheme

4.2 Absolute Maximum Ratings

If the load applied to the device exceeds the values specified in the "Absolute Maximum Ratings" table (Table 11, Table 12), it may result in permanent damage to the device. The maximum load values provided are only the limits that the device can withstand, and it does not imply flawless functional operation under these conditions. Prolonged operation of the device at maximum values can affect its reliability.

Product Naming Rule

Table 11 Voltage characteristics

Symbol	Parameter	Min	Max	Unit
$V_{DD}-V_{SS}^{(1)}$	External main supply voltage	-0.3	5.8	V
$V_{IN}^{(2)}$	Input voltage on other pins	-0.3	5.8	

- 1) All power (V_{DD}) and ground (V_{SS}) pins must always be connected to an external power supply within the allowed range.
- 2) The input voltage on pins must always comply with the range of V_{IN} . Refer to the table below for information on the allowed maximum injection current values.

Table 12 Current characteristics

Symbol	Parameter	Max	Unit
$I_{VDD}^{(1)}$	Total current through the VDD power line (source)	+60	mA
$I_{VSS}^{(1)}$	Total current through the VSS ground line (sink)	-60	
I_{IO}	Output sourcing current on any I/O and control pins	+20	
	Output sinking current on any I/O and control pins	-20	
$I_{INJ(PIN)}^{(2)(3)}$	Injection current on the NRST pin	± 5	
$\sum I_{INJ(PIN)}^{(2)(4)}$	Injection current on other pins	± 10	

- 1) Within the allowed range, all main power V_{DD} and ground V_{SS} pins must always be connected to an external power source.
- 2) Forward/reverse injection current can interfere with the analog performance of the device.
- 3) When $V_{IN} > V_{DD}$, forward injection current is generated; when $V_{IN} < V_{SS}$, reverse injection current is generated.
- 4) When multiple inputs have injection currents simultaneously, the maximum value of $\sum I_{INJ(PIN)}$ is equal to the absolute sum of the forward injection current and the reverse injection current (instantaneous values).

4.3 Operating Conditions

4.3.1 General Operating Conditions

Table 13 General operating conditions

Symbol	Parameter	Conditions	Min	Typical	Max	Unit
f_{HCLK}	Internal AHB clock frequency	-			60	MHz
f_{PCLK1}	Internal APB1 clock frequency	-			60	
V_{DD}	Operating Voltage	-	2.5		5.5	V
T_A	Ambient temperature	-	-40		105	$^{\circ}C$
$T_J^{(1)}$	Junction temperature range	-	-40		125	$^{\circ}C$

- 1) $T_J=125^{\circ}C$ is the absolute maximum rating.

4.3.2 Power-up and Power-down Operating Conditions

The parameters given in table below are derived from tests performed under general operating conditions.

Product Naming Rule

Table 14 Power-up and power-down operating conditions ⁽¹⁾ ⁽²⁾ ⁽³⁾

Symbol	Conditions	Min	Typical	Max	Unit
t_{VDD}	V_{DD} rising time t_r	300		50000	us
	V_{DD} falling time t_f	300		50000	
V_{ft}	Power-down threshold voltage	0			mV

- 1) Derived from overall evaluation, not tested in production.
- 2) The on-chip V_{DD} waveform during power-down should follow the t_r and t_f stages as shown in the waveform diagram below.
- 3) The chip should be powered up from 0V to ensure reliable power-up.

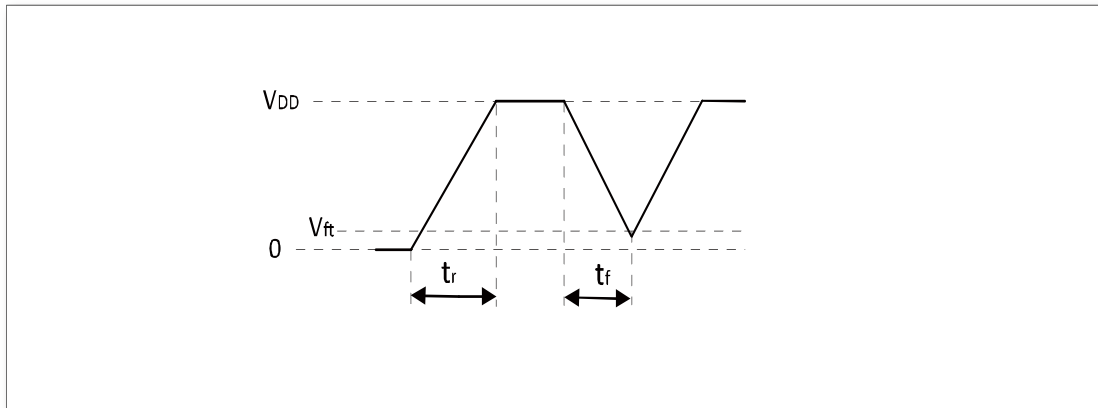

Figure 12 Power-up and power-down waveform

4.3.3 Embedded Reset and Power Control Block Characteristics

The parameters given in the table below are derived from tests performed under the listed ambient temperature and V_{DD} supply voltage according to the general operating conditions table.

Table 15 Embedded reset and power control block characteristics ⁽¹⁾

Symbol	Parameter	Condition	Min	Typical	Max	Unit
V_{PVD}	Level selection for programmable voltage detector	PLS[3:0]=0010 (rising edge)		2.4		V
		PLS[3:0]=0010 (falling edge)		2.3		
		PLS[3:0]=0011 (rising edge)		2.7		
		PLS[3:0]=0011 (falling edge)		2.6		
		PLS[3:0]=0100 (rising edge)		3.0		
		PLS[3:0]=0100 (falling edge)		2.9		
		PLS[3:0]=0101 (rising edge)		3.3		
		PLS[3:0]=0101 (falling edge)		3.2		
		PLS[3:0]=0110 (rising edge)		3.6		
		PLS[3:0]=0110 (falling edge)		3.5		
		PLS[3:0]=0111 (rising edge)		3.9		

Symbol	Parameter	Condition	Min	Typical	Max	Unit
		PLS[3:0]=0111 (falling edge)		3.8		
		PLS[3:0]=1000 (rising edge)		4.2		
		PLS[3:0]=1000 (falling edge)		4.1		
		PLS[3:0]=1001 (rising edge)		4.5		
		PLS[3:0]=1001 (falling edge)		4.4		
		PLS[3:0]=1010 (rising edge)		4.8		
		PLS[3:0]=1010 (falling edge)		4.7		
V _{POR}	Power-on reset threshold	-		2.2		V
V _{hyst_POR/PDR}	POR/PDR hysteresis	-		60		mV
T _{RSTTEMPO} ⁽²⁾	Reset duration	-		1.84		ms

- 1) Derived from comprehensive evaluation, not tested in production.
- 2) Reset Duration: Time from POR release to the execution of the user's first application code.

4.3.4 Built-in Reference Voltage

The parameters given in the table below are derived from tests under the listed ambient temperature and V_{DD} supply voltage according to the general operating conditions table.

Table 16 Built-in reference voltage

Symbol	Parameter	Condition	Min	Typical	Max	Unit
V _{REFINT} ⁽¹⁾	Built-in reference voltage	T _A =25°C	1.14	1.2	1.26	V
T _{s_vrefint}	Sampling and hold time of ADC when reading internal reference voltage	-		11.8		us

- 1) The low 16 bits of the internal Flash address 0x1FFFF7E0 store the ADC sampling value of the VREFINT voltage reference at 3.3V.

4.3.5 Supply Current Characteristics

Supply current consumption is a comprehensive indicator of various parameters and factors, including operating voltage, ambient temperature, load on I/O pins, software configuration of the product, operating frequency, switching rate of I/O pins, location of the program in memory, and executed code, etc.

All measured current consumption values in this section for all operating modes are obtained by executing a simplified code.

Current Consumption

The microcontroller is placed under the following conditions:

- All I/O pins are in input mode and connected to a static level (V_{DD} or V_{SS}).
- All peripherals are in the off state unless otherwise specified.
- Access time of the Flash memory is adjusted to the frequency of f_{HCLK} (0 wait state when f_{HCLK} is 0~30 MHz, 1 wait state when f_{HCLK} is 30~60 MHz).

Product Naming Rule

- Instruction prefetch feature is enabled. When peripherals are enabled: $f_{HCLK} = f_{PCLK1}$.

Note: The instruction prefetch feature must be set before setting the clock and bus dividers.

The parameters given in the table below are derived from tests under the listed ambient temperature and V_{DD} supply voltage according to the general operating conditions table.

Table 17 Typical current consumption in operating mode

Symbol	Parameter	Condition	$f_{HCLK}(Hz)$ ⁽¹⁾	Typical All peripherals enabled				Typical All peripherals disabled				Unit
				-40°C	25°C	85°C	105°C	-40°C	25°C	85°C	105°C	
I_{DD}	Supply current in operating mode	Internal clock	60MHz	8.44	8.61	8.78	8.80	7.00	7.08	7.27	7.35	mA
			30MHz	5.29	5.33	5.38	5.41	4.58	4.61	4.67	4.71	
			15MHz	3.42	3.41	3.43	3.45	3.05	3.02	3.05	3.07	
			7.5MHz	2.44	2.40	2.41	2.42	2.25	2.20	2.21	2.22	
			40KHz ⁽²⁾	1.10	1.02	1.00	1.01	1.09	1.00	0.98	0.99	

1) The HCLK frequency is the AHB clock obtained by dividing the HSI 60MHz clock.

2) The LSI clock is set to 40KHz as the system clock, with the HSI turned off.

Table 18 Typical current consumption in sleep mode

Symbol	Parameter	Condition	$f_{HCLK}(Hz)$ ⁽¹⁾	Typical All peripherals enabled				Typical All peripherals disabled				Unit
				-40°C	25°C	85°C	105°C	-40°C	25°C	85°C	105°C	
I_{DD}	Supply current in sleep mode	Internal clock	60MHz	3.55	3.52	3.53	3.54	2.31	2.25	2.25	2.26	mA
			30MHz	2.51	2.46	2.46	2.47	1.89	1.83	1.82	1.83	
			15MHz	1.96	1.90	1.89	1.90	1.65	1.58	1.57	1.58	
			7.5MHz	1.69	1.62	1.61	1.61	1.54	1.46	1.45	1.46	
			40KHz ⁽²⁾	1.08	1.00	0.99	1.00	1.08	1.00	0.99	1.00	

1) The HCLK frequency is the AHB clock obtained by dividing the HSI 60MHz clock.

2) The LSI clock is set to 40KHz as the system clock, with the HSI turned off.

Table 19 Typical current consumption in stop mode

Symbol	Parameter	Condition	Typical				Unit
			-40°C	25°C	85°C	105°C	
$I_{DD}^{(1)}$	Supply current in stop mode	Enter stop mode after reset, $V_{DD}=3.3V$	113.3	106.8	111.3	118.4	μA

1) I/O state is set to analog input.

Built-in Peripheral Current Consumption

The built-in peripheral current consumption is presented in Table 20 Built-in peripheral current consumption⁽¹⁾. The MCU operates under the following working conditions:

- All I/O pins are in input mode and connected to a static level- V_{DD} or V_{SS} .
- All peripherals are turned off, unless otherwise specified.
- The given values are calculated by measuring the current consumption
 - With all peripherals clocked off
 - With only one peripheral clocked on
- Ambient temperature and V_{DD} power supply conditions are listed in Table 13.

Product Naming Rule

Table 20 Built-in peripheral current consumption⁽¹⁾

Symbol	Peripheral	Bus	Typical	Unit
I _{DD}	GPIOB	AHB	0.30	uA/MHz
	GPIOA		0.31	
	HWDIV		0.88	
	DMA		0.86	
	TIM1	APB1	4.65	
	TIM2		3.72	
	ADC1		2.98	
	USART1		1.86	
	TIM14		1.61	
	TIM13		1.60	
	TIM6		1.29	
	COMP		0.51	
	SYSCFG		0.11	
	DBG		0.05	
	PWR		0.01	
	EXTI		0.01	
	IWDG		0.01	

1) $f_{HCLK} = 60\text{MHz}$, $f_{APB1} = f_{HCLK}$, the prescaler coefficient of each peripheral is the default value.

Wake-up Time for Low-power Mode

The wake-up times listed in the following table are measured during the wake-up phase of the internal clock HSI. All times are measured under general operating conditions with the ambient temperature and supply voltage within the specified range.

Table 21 Low-power mode wake-up time

Symbol	Parameter	Condition	Typical	Unit
t _{WUSLEEP}	Wake-up from sleep mode	The system clock is HSI	1.5	μS
t _{WUSTOP}	Wake-up from stop mode	The system clock is HSI	65	μS

4.3.6 Internal Clock Source Characteristics

The characteristics listed in the following table are measured under general operating conditions with the ambient temperature and supply voltage within the specified range.

High-Speed Internal (HSI) Oscillator

Table 22 HSI oscillator characteristics⁽¹⁾

Symbol	Parameter	Condition	Min	Typical	Max	Unit
f _{HSI}	Frequency	-		60		MHz
ACC _{HSI}	Accuracy of HSI oscillator	T _A = -40°C~105°C	-2.5		2.5	%
		T _A = -10°C~85°C	1.5		1.5	%
		T _A = 25°C	-1		1	%
t _{SU(HSI)}	HSI oscillator start-up time	-		61		μS

Product Naming Rule

Symbol	Parameter	Condition	Min	Typical	Max	Unit
I _{DD(HSI)}	Power consumption of HIS oscillator	-	145.7	183.2	239.3	μA

1) Derived from comprehensive evaluation, not tested in production.

Low-Speed Internal (LSI) Oscillator

Table 23 LSI oscillator characteristics⁽¹⁾

Symbol	Parameter	Condition	Min	Typical	Max	Unit
f _{LSI} ⁽²⁾	Frequency	T _A = -40°C ~ 105°C	20	40	60	KHz
t _{SU(LSI)} ⁽²⁾	LSI oscillator start-up time	-			300	μS
I _{DD(LSI)} ⁽²⁾	Power consumption of LIS oscillator	-		0.34		μA

1) V_{DD} = 3.3V, unless otherwise specified

2) Derived from comprehensive evaluation, not tested in production.

4.3.7 Memory Characteristics

Table 24 FLASH memory characteristics

Symbol	Parameter	Condition	Min	Typical	Max	Unit
t _{prog}	16-bit programming time	-		164		μS
	32-bit programming time			177		
t _{ERASE}	Page (1024 bytes) erase time	-		5.18		mS
t _{ME}	Mass erase time	-		50.98		mS

Table 25 Flash memory endurance and data retention period⁽¹⁾

Symbol	Parameter	Condition	Min	Unit
N _{END}	Erase count		2	Ten thousand times
T _{DR}	Data retention	T _A = 105°C	10	Years
		T _A = 25°C	100	

1) Derived from comprehensive evaluation, not tested in production.

4.3.8 EMC Characteristics

Sensitivity tests are performed on a sample basis during device comprehensive evaluation.

Functional EMS (Electromagnetic Sensitivity)

During the operation of a simple application (flashing 2 LEDs through I/O ports), the test sample is subjected to one type of electromagnetic interference until an error occurs. The error is indicated by the LED flashing.

- EFT: A series of transient voltage pulses (positive and negative) is applied to V_{DD} and V_{SS} by a 100pF capacitor until a functional error occurs. This test complies with the IEC61000-4-4 standard.

The test results are presented in the following table.

Table 26 EMS characteristics

Symbol	Parameter	Condition	Level/Class
V _{FESD}	Voltage limits that, when applied to any I/O pin, result in functional errors	V _{DD} = 3.3V, T _A = +25°C, f _{HCLK} = 60MHz, conforming to IEC61000-4-2	2A
V _{FEFT}	Voltage limits of transient pulse groups that, when applied through a 100pF capacitor on V _{DD} and V _{SS} , result in functional errors	V _{DD} = 3.3V, T _A = +25°C, f _{HCLK} = 60MHz, conforming to IEC61000-4-4	2A

Designing reliable software to mitigate noise issues

EMC evaluation and optimization at the device level are performed in typical application environments. It should be noted that good EMC performance is closely related to user applications and specific software. Therefore, it is recommended that users implement EMC optimization and conduct certification tests related to EMC.

Software recommendations

The software flowchart must include controls to prevent program runaway, such as:

- Corrupted program counters
- Unexpected resets
- Critical data corruption (control registers, etc.)

Prequalification trials

Many common failures (unexpected resets and program counter corruption) can be reproduced by manually introducing a low level on NRST.

During ESD testing, voltages exceeding application requirements can be directly applied to the chip. The software needs to be strengthened to prevent irreversible errors when unexpected actions are detected.

4.3.9 Functional EMS (Electrical Sensitivity)

Based on three different tests (HBM, CDM, LU) using specific measurement methods, the chip undergoes strength testing to determine its performance in terms of electrical sensitivity.

Table 27 ESD characteristics

Symbol	Parameter	Condition	Level	Max	Unit
VESD(HBM)	Electrostatic discharge voltage (human body model)	T _A = 25°C, conforming to ESDA/JEDEC JS-001-2017	3A	±6000	V
VESD(CDM)	Electrostatic discharge voltage (charged device model)	T _A = 25°C, conforming to ESDA/JEDEC JS-002-2018	C3	±2000	V
ILU	Latch-up current	T _A = 105°C, conforming to JESD78E	II, A	±300	mA

- 1) Derived from comprehensive evaluation, not tested in production.
- 2) The ESD characteristics are only applicable to the main chip and not to the gate driver.

4.3.10 GPIO Port General Input/Output Characteristics

Product Naming Rule

Unless otherwise specified, the parameters listed in the table below are derived from tests performed under the conditions summarized in Table 13. All I/O ports are CMOS-compliant.

Table 28 IO static characteristics ⁽¹⁾

Symbol	Parameter	Condition	Min	Typical	Max	Unit
V _{IL}	Input low-level voltage	3.3V CMOS port	-	-	0.8	V
V _{IL}	Input low-level voltage	5V CMOS port	-	-	0.3 * V _{DD}	V
V _{IH}	Input high-level voltage	3.3V CMOS port	2.0	-	-	V
V _{IH}	Input high-level voltage	5V CMOS port	0.7 * V _{DD}	-	-	V
V _{hy}	I/O pin Schmitt trigger voltage hysteresis	3.3V	0.1 * V _{DD}	0.50	-	V
V _{hy}	I/O pin Schmitt trigger voltage hysteresis	5V	0.1 * V _{DD}	0.60	-	V
I _{lkg}	Input leakage current ⁽²⁾	3.3V	-1	-	1	μA
I _{lkg}	Input leakage current ⁽²⁾	5V	-1	-	1	μA
R _{PU}	Weak pull-up equivalent resistance	3.3V V _{IN} = V _{SS}	50	60	75	kΩ
R _{PU}	Weak pull-up equivalent resistance	5V V _{IN} = V _{SS}	50	60	75	kΩ
R _{PD}	Weak pull-down equivalent resistance	3.3V V _{IN} = V _{DD}	50	60	75	kΩ
R _{PD}	Weak pull-down equivalent resistance	5V V _{IN} = V _{DD}	50	60	75	kΩ
C _{IO}	I/O pin capacitance	-	-	-	10	pF

1) Derived from comprehensive evaluation, not tested in production.

2) In case of a negative current back flow in an adjacent pin, the leakage current may exceed the maximum value.

Output drive current

The GPIOs (General Purpose Input/Output) can sink or source current up to ±20mA.

In user applications, the number of I/O pins must ensure that the drive current does not exceed the absolute maximum ratings given in section 4.2:

- The sum of all I/O ports' current drawn from V_{DD}, plus the MCU's maximum operating current drawn from V_{DD}, must not exceed the absolute maximum rated value I_{VDD}.
- The sum of all I/O ports' current sunk from V_{SS}, plus the MCU's maximum operating current sunk from V_{SS}, must not exceed the absolute maximum rated value I_{VSS}.

Output voltage

Unless specifically stated, the parameters listed in the table below were measured under conditions where the ambient temperature and V_{DD} power supply voltage comply with the conditions in table 13. All I/O ports are CMOS compatible.

Table 29 Output voltage characteristics ⁽¹⁾

Symbol	Parameter	Condition	Typical	Unit
V _{OL}	Output low level	I _{IO} = 6mA, V _{DD} =3.3V	0.15	V
V _{OH}	Output high level		3.0	
V _{OL}	Output low level	I _{IO} = 8mA, V _{DD} =3.3V	0.21	
V _{OH}	Output high level		2.98	
V _{OL}	Output low level		0.59	

Product Naming Rule

Symbol	Parameter	Condition	Typical	Unit
V_{OH}	Output high level	$ I_{IO} =20\text{mA}$, $V_{DD}=3.3\text{V}$	2.31	

- 1) Derived from comprehensive evaluation, not tested in production.

Input/output AC characteristics

The definition and values of AC characteristics of input and output are provided in Figure 12 and Table 30.

Unless otherwise specified, the parameters listed in the table below are measured under the conditions of ambient temperature and supply voltage specified in the general operating conditions table.

Table 30 Input/output AC characteristics ⁽¹⁾

Symbol	Parameter	Condition	Typical	Unit
$t_{f(IO)out}$	Output fall time	$C_L = 50\text{pF}$ $V_{DD}=3.3\text{V}$	5.3	ns
$t_{r(IO)out}$	Output rise time		5.8	ns

- 1) The maximum output frequency of IO is defined in Figure 11.
- 2) Guaranteed by design, not tested in production.

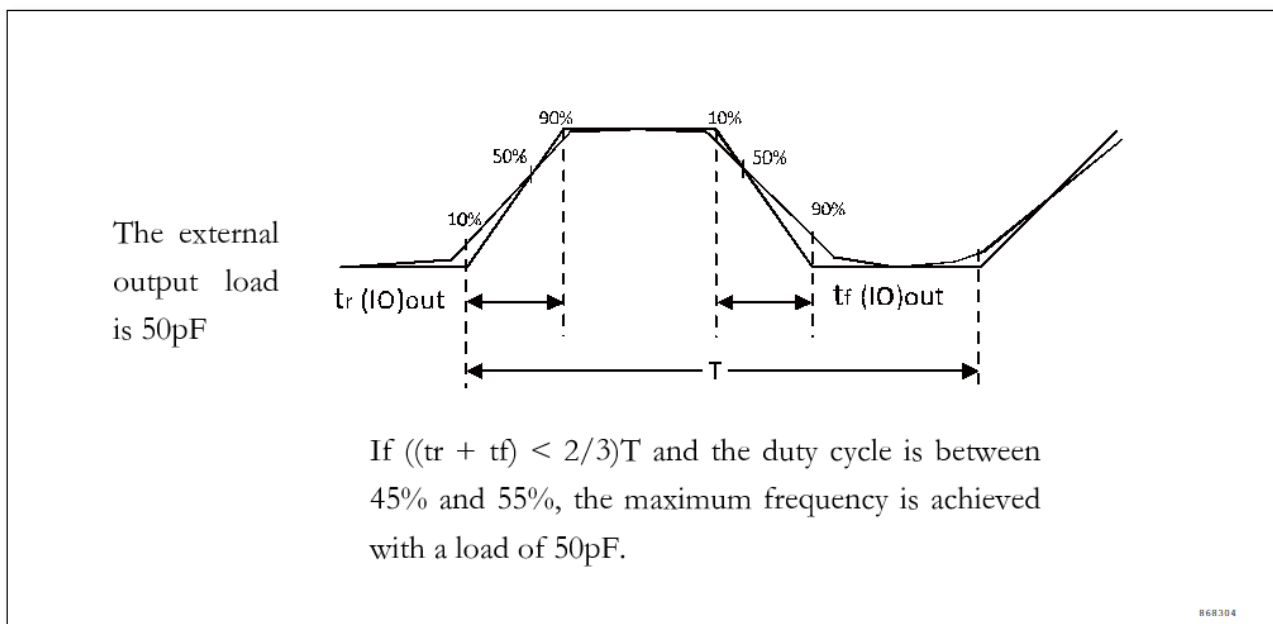

Figure 13 Definition of input and output AC characteristics

4.3.11 NRST Pin Characteristics

Unless otherwise specified, the parameters listed in the following table are measured under the conditions of ambient temperature and V_{DD} supply voltage specified in Table 13.

Table 31 NRST pin characteristics ⁽¹⁾

Symbol	Parameter	Condition	Min	Typical	Max	Unit
$V_{IL(NRST)}$	NRST input low level voltage	$V_{DD}=3.3\text{V}$			0.8	V
$V_{IH(NRST)}$	NRST input high level voltage	$V_{DD}=3.3\text{V}$	$0.7 * V_{DD}$			V
$V_{hys(NRST)}$	NRST Schmitt trigger voltage hysteresis	$V_{DD}=3.3\text{V}$		0.50		V

Product Naming Rule

Symbol	Parameter	Condition	Min	Typical	Max	Unit
R_{PU}	Weak pull-up equivalent resistor	$V_{IN} = V_{SS}$	50	60	75	$k\Omega$
$V_{F(NRST)}$	NRST input filtered pulse	-			0.5	μS
$V_{NF(NRST)}$	NRST input non-filtered pulse	-	0.7			μS

1) Guaranteed by design, not tested in production.

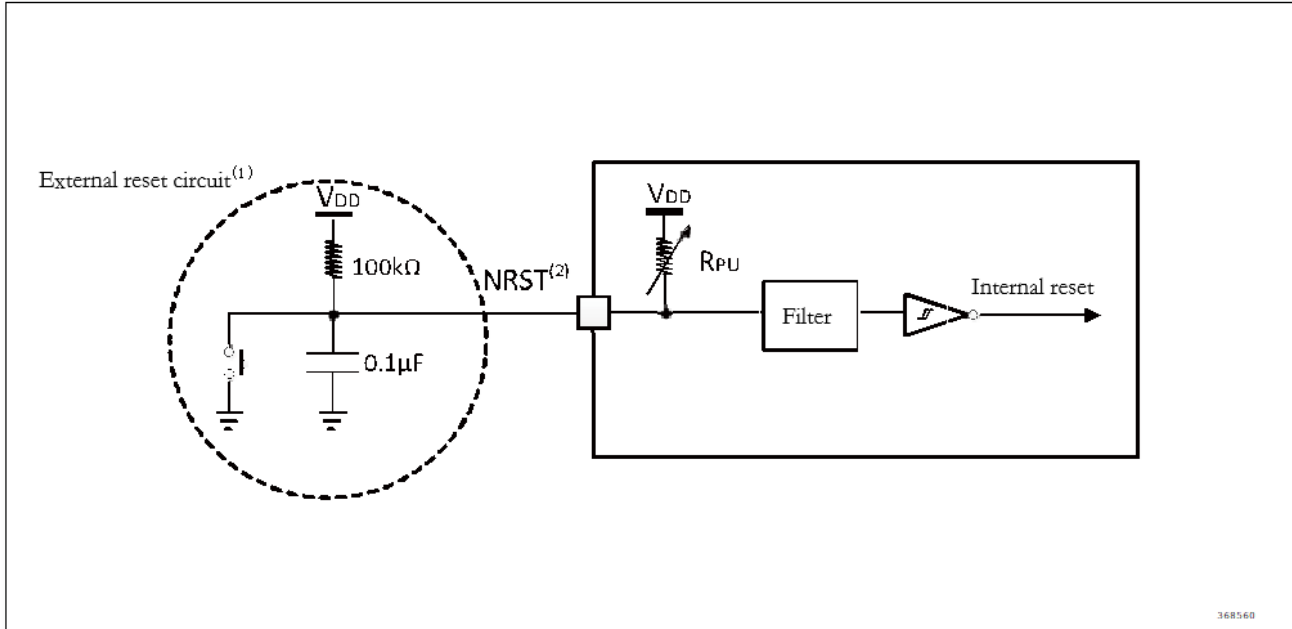

Figure 14 Recommended NRST pin protection

- 1) The reset network is to prevent parasitic reset.
- 2) The user must ensure that the potential of the NRST pin is below the maximum $V_{IL(NRST)}$ listed in Table 31, otherwise the MCU cannot be reset.

4.3.12 Timer Characteristics

Table 32 TIMx⁽¹⁾ characteristics

Symbol	Parameter	Condition	Min	Max	Unit
$t_{res(TIM)}$	Timer resolution time	-	1	-	$t_{TIMxCLK}$
		$f_{TIMxCLK} = 60MHz$	16.7	-	nS
f_{EXT}	External clock frequency for timers CH1 to CH4	-	0	-	MHz
		$f_{TIMxCLK} = 60MHz$	-	30	
Re_{TIM}	Timer resolution	-	-	16/32	位
$t_{COUNTER}$	Clock cycle of 16-bit counter	-	1	65536	$t_{TIMxCLK}$
		$f_{TIMxCLK} = 60MHz$	0.0167	1092.3	μS
t_{MAX_COUNT}	Maximum possible counting period of 16-bit counter (TIM_PSC adjustable)	-	-	65536	$t_{TIMxCLK}$
		$f_{TIMxCLK} = 60MHz$		71.6	S
t_{MAX_IN}	Maximum input frequency for TIM	$f_{HCLK} = 60MHz$		60	MHz

1) Guaranteed by design, not tested in production.

4.3.13 Communication Interfaces

USART characteristics

Unless otherwise specified, the parameters listed in Table 33 are measured under the conditions of ambient temperature, f_{PCLK1} frequency, and V_{DD} supply voltage specified in Table 13.

Table 33 USART synchronous mode characteristics ⁽¹⁾

Symbol	Parameter	Condition	Min	Max	Unit
$f_{SCK1}/t_{c(SCK)}$	SPI clock frequency	Master mode	-	7.5	MHz
		Slave mode	-	7.5	
$t_{r(SCK)}$	SPI clock rise time	Load capacitance: C = 15pF	-	6	ns
$t_{f(SCK)}$	SPI clock fall time	Load capacitance: C = 15pF	-	6	nS
$t_{w(SCKH)}^{(1)}$	SCK high time	-	$t_{c(SCK)}/2 - 6$	$t_{c(SCK)}/2 + 6$	nS
$t_{w(SCKL)}^{(1)}$	SCK low time	-	$t_{c(SCK)}/2 - 6$	$t_{c(SCK)}/2 + 6$	nS
$t_{su(MI)}^{(1)}$	Data Input Setup Time	Master mode, $f_{PCLK} = 60\text{MHz}$, prescaler = 8, high-speed mode	5	-	nS
$t_{su(SI)}^{(1)}$		Slave mode	5	-	nS
$t_{h(MI)}^{(1)}$	Data input hold time	Master mode, $f_{PCLK} = 60\text{MHz}$, prescaler = 8, high-speed mode	5	-	nS
$t_{h(SI)}^{(1)}$		Slave mode	5	-	nS
$t_{v(MO)}^{(1)}$	Data output valid time	Master mode (after enabling the edge)	-	10	nS
$t_{v(SO)}^{(1)}$	Data output valid time	Slave mode (after enabling the edge)	-	26	nS

- 1) Guaranteed by design, not tested in production.
- 2) The minimum value represents the minimum time for driving the output, while the maximum value represents the maximum time for correctly acquiring data.
- 3) The minimum value represents the minimum time for disabling the output, while the maximum value represents the maximum time for putting the data line in a high-impedance state.

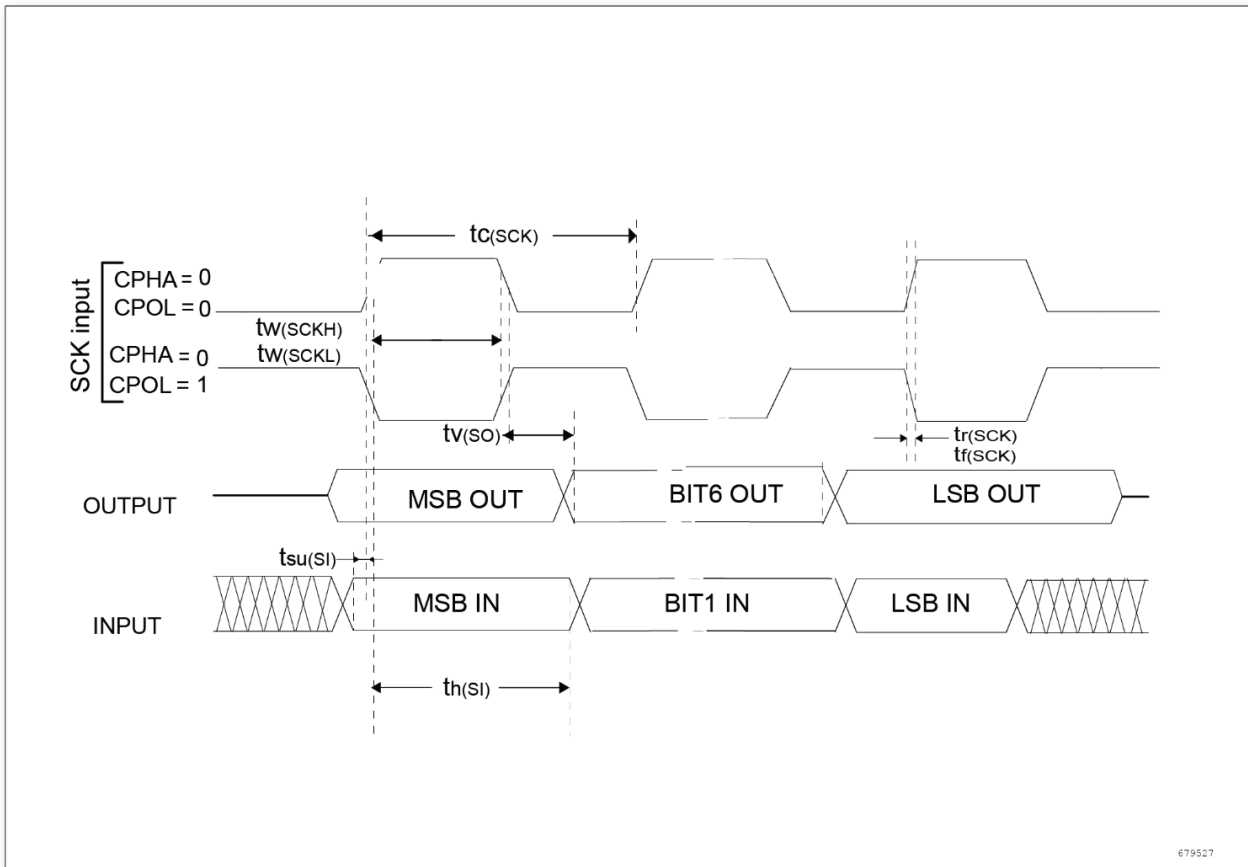

Figure 15 USART synchronous timing

4.3.14 ADC Characteristics

Unless otherwise specified, the parameters in the following table are measured using the ambient temperature, f_{CLK1} frequency, and V_{DD} power supply voltage in accordance with the conditions specified in the general operating conditions table.

Table 34 ADC characteristics ⁽¹⁾

Symbol	Parameter	Condition	Min	Typical	Max	Unit
V_{DD}	Supply voltage	-	2.5		5.5	V
f_{ADC}	ADC clock frequency	$V_{DD} \geq 2.5V$			15	MHz
f_s	Sampling rate	12bits; $V_{DD} \geq 2.5V$			1	MHz
f_{TRIG}	External trigger frequency ⁽²⁾	12bits; $f_{ADC}=15MHz$			1	MHz
		12bits			15	$1/f_{ADC}$
V_{AIN}	Conversion voltage range	$V_{DD} \geq 2.5V$	0		V_{DD}	V
R_{AIN}	External input impedance	-	See the formula below			k Ω
R_{ADC}	Sampling switch resistance	-			1.5	k Ω
C_{ADC}	Internal sampling and holding capacitance	-			5	pF
t_{STAB}	Power-up time	-			10	μs
t_{lat}	Injection-trigger conversion delay	-			512	$1/f_{ADC}$

Product Naming Rule

Symbol	Parameter	Condition	Min	Typical	Max	Unit
t _{latr}	Regular-trigger conversion delay				512	1/f _{ADC}
t _s	Sampling time	f _{ADC} =15MHz	0.167		16.03	μS
		-				1/f _{ADC}
t _{CONV}	Total conversion time (including sampling time)	12bits; f _{ADC} =15MHz	1		16.87	μS
		12bits				1/f _{ADC}
ENOB	Effective number of bits	12bits; V _{DD} ≥ 3.3V; f _{ADC} =15MHz		10.9		bit

- 1) Guaranteed by design, not tested in production.
- 2) For external triggering, a delay of 1/f_{ADC} must be added to the timing.

Input Impedance Table

$$R_{AIN} < \frac{T_s}{f_{ADC} \times C_{ADC} \times \ln(2^{n+2})} - R_{ADC}$$

The above formula is used to determine the maximum external impedance to ensure that the error is less than 1/4 LSB. Here, n = 12 (representing 12-bit resolution) and it is measured at f_{ADC} = 15MHz.

Table 35 Maximum R_{AIN} at f_{ADC}=15MHz⁽¹⁾

Ts (Cycle)	t _s (μS)	Maximum R _{AIN} (kΩ)
2.5	0.167	1.9
3.5	0.233	3.3
4.5	0.300	4.7
5.5	0.367	6.1
6.5	0.433	7.4
7.5	0.500	8.8
8.5	0.567	10.2
14.5	0.967	18.4
29.5	1.967	39.0
42.5	2.833	56.9
56.5	3.767	76.1
72.5	4.833	98.1
240.5	16.033	328.9

- 1) Guaranteed by design, not tested in production.

Table 36 ADC static parameter^{(1) (2)}

Symbol	Parameter	Condition	Typical	Unit
ET	Overall error	f _{PCLK1} = 60MHz, f _{ADC} = 15MHz, R _{AIN} < 0.1 kΩ, V _{DD} = 3.3V, T _A = 25°C	-6/+7	LSB
EO	Offset error		-4.8/+6	
EG	Gain error		-1.2/+5.8	
ED	Differential linearity error		-0.9/1.5	
EL	Integral linearity error		-4/+4.2	

- 1) The relationship between ADC accuracy and reverse injection current: It is necessary to avoid injecting reverse current into any standard analog input pin, as it significantly degrades the accuracy of the conversion performed on another analog input pin. It is recommended to add a Schottky diode between the pin and ground on standard analog pins where reverse injection current may occur.

- 2) Derived from comprehensive evaluation, not tested in production.

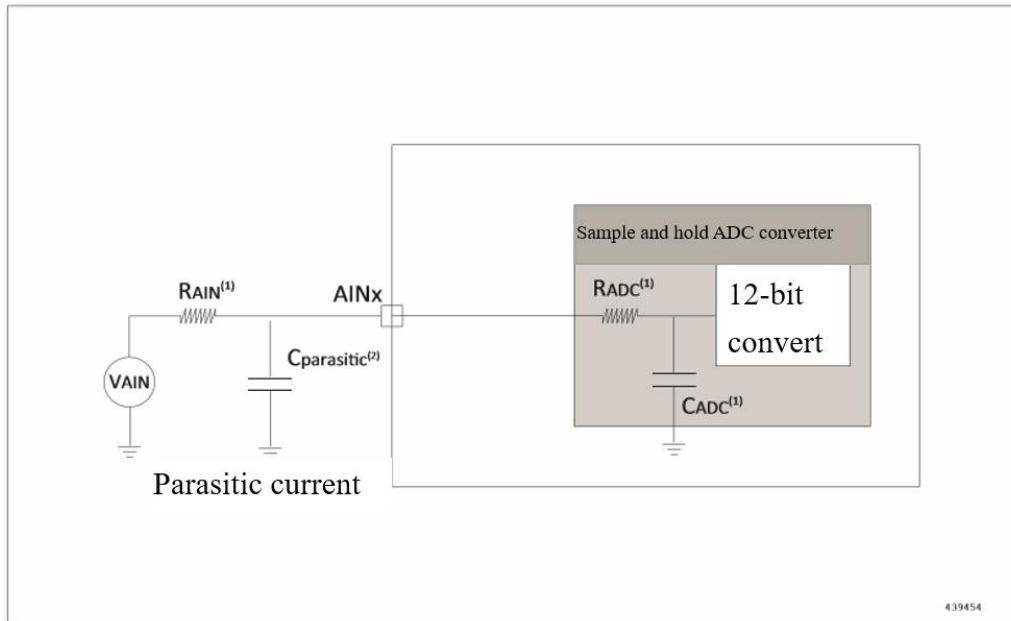

Figure 16 Typical connection diagram using ADC

- 1) Refer to Table 35 for the values of R_{AIN} , R_{ADC} and C_{ADC} .
- 2) $C_{parasitic}$ represents the capacitance between the PCB (which is dependent on soldering and PCB layout quality) and the solder pads (approximately 7pF). A high value of $C_{parasitic}$ will degrade the accuracy of the conversion. To address this issue, it is recommended to reduce f_{ADC} .

PCB design recommendations

The decoupling of the power supply must be connected as shown in the figure below. The 10nF capacitor depicted in the figure must be a ceramic capacitor and should be placed as close as possible to the MCU chip.

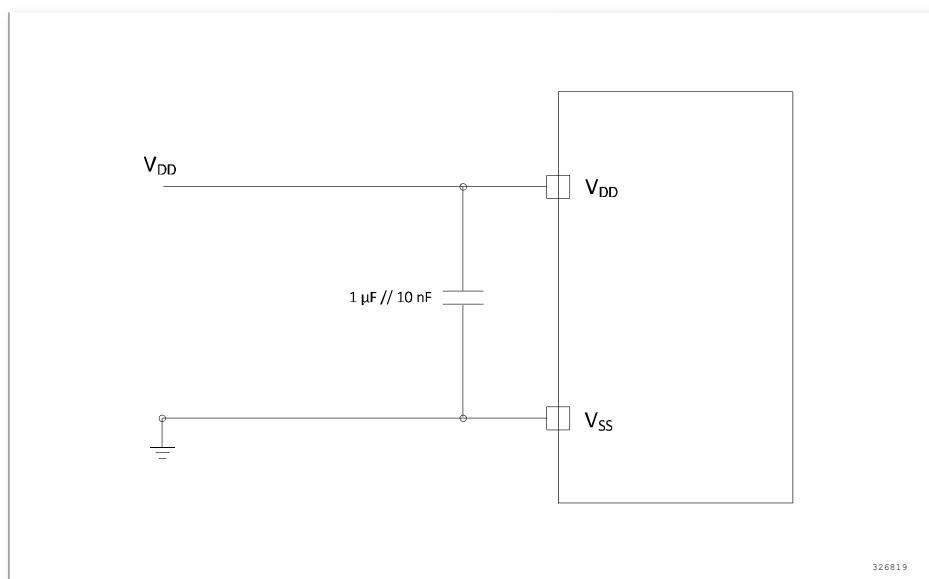

Figure 17 Power supply and reference power supply decoupling circuit

4.3.15 Temperature Sensor Characteristics

Product Naming Rule

Table 37 Temperature sensor characteristics ⁽³⁾

Symbol	Parameter	Min	Typical	Max	Unit
T _L ⁽¹⁾	Linearity of V _{SENSE} relative to temperature		±5		°C
Avg Slope ⁽¹⁾	Average slope		-3.89		mV/°C
V _{25°C} ⁽¹⁾	Voltage at 25°C		1.289		V
t _{START} ⁽²⁾	Settling time		1		μS
t _{s_temp} ⁽²⁾	ADC sampling time when reading temperature		11.8		μS

1) Derived from comprehensive evaluation, not tested in production.

2) Guaranteed by design, not tested in production.

3) Temperature formula: $T_{\text{sensor}} = 25 + (\text{ADCvalue} * v_{\text{dd}} - \text{offset} * 3300) / (4096 * \text{Avg_Slope})$, where the offset is stored in the lower 12 bits of address 0x1FFFF7F6.

4.3.16 Comparator Characteristics

Table 38 Comparator characteristics

Comparator characteristics						
Symbol	Parameter	Register configuration	Min	Typical	Max	Unit
V _{IN}	Input Voltage	-	0.6	-	V _{DD} -1	V
t _{HYST}	Hysteresis	00(hysteresis), high power	-	0	-	mV
		00(hysteresis), low power	-	0	-	mV
		01(hysteresis), high power	15	22	43	mV
		01(hysteresis), low power	13	15	23	mV
		10(hysteresis), high power	32	45	92	mV
		10(hysteresis), low power	25.2	32	46.7	mV
		11(hysteresis), high power	55	85	182	mV
		11(hysteresis), low power	25.5	60	83.9	mV
V _{OFFSET}	Offset voltage	-		+/-6	+/-10.4	mV
t _{DELAY}	Propagation delay ⁽¹⁾	00 (high power)	3.7	10.7	43	ns
		01 (medium power)	10.5	34.9	83	ns
		10 (low power)	13.8	49	114	ns
		11 (ultra-low power)	22.2	86	194.5	ns
I _q	Average operating current	00 (high power)	6.5	45	205.4	μA
		01 (medium power)	3.3	21.7	81.3	μA
		10 (low power)	2.6	15.3	59.6	μA
		11 (ultra-low power)	1.7	8.8	35.3	μA

Product Naming Rule

- 1) Time difference between 50% output transition and input transition.

4.3.17 Operational Amplifier Characteristics

Table 39 Operational amplifier characteristics

Symbol	Parameter	Condition	Min	Typical	Max	Unit
V _{DD}	Supply voltage	-	2.5		5.5	V
V _{OFFSET}	Input bias voltage	Common mode input 1/2 * V _{DD}	-6	-	6	mV
I _{LOAD}	Drive current	Drive current (sinking current) (V _{DD} =5V V _{OUT} =1V)			15	mA
C _{LOAD}	Capacitive load	-			30	pF
CMRR	Common mode rejection ratio	-		80		dB
PSRR	Power supply rejection ratio	-		80		dB
GBW	Gain-bandwidth product	-		12		MHz
SR	Slew rate	-		7		V/us
GOL	Open-loop gain	-	90	110	120	dB

- 1) Guaranteed by design, not tested in production.

5 Gate Driver

5.1 Operating Condition

Table 40 Gate driver absolute maximum ratings

Symbol	Description	Min	Max	Unit
VCC	LDO and gate driver power supply voltage	-0.3	20	V
VREG5	5V linear regulator output	-0.3	6	
HIN1,2,3	Gate driver upper bridge arm input	-0.3	VCC + 0.3	
LIN1,2,3	Gate driver lower bridge arm input	-0.3	VCC + 0.3	
VB1,2,3	Gate driver bootstrap power supply output	-0.3	220	
VS1,2,3	Power switch circuit output phase node	-10	VB + 0.3	
HO1,2,3	Gate driver upper bridge arm output	VS – 0.3	VB + 0.3	
LO1,2,3	Gate driver lower bridge arm output	- 0.3	VCC + 0.3	
PD	Package power dissipation at TA<=25°C		0.625	W
RthJA	Thermal resistance		200	°C/W
TJ	Junction temperature		150	°C
TS	Storage temperature	-55	150	
TL	Lead temperature during soldering (10 seconds hold)		300	

Table 41 Gate driver recommended operating range

Symbol	Description	Min	Max	Unit
VCC	LDO and gate driver power supply voltage	7	18	V
VREG5	5V linear regulator output	4.5	5.5	
HIN1,2,3	Gate driver upper bridge arm input	0	VCC	
LIN1,2,3	Gate driver lower bridge arm input	0	VCC	
VB1,2,3	Gate driver bootstrap power supply output	VS + 5	VS + 18	
VS1,2,3	Power switch circuit output phase node	-7	200	
HO1,2,3	Gate driver upper bridge arm output	VS	VB	
LO1,2,3	Gate driver lower bridge arm output	0	VCC	
TA	Ambient Temperature	-40	125	°C

5.2 Electrical Characteristics

The characteristics of the gate driver are as shown in the following figure.

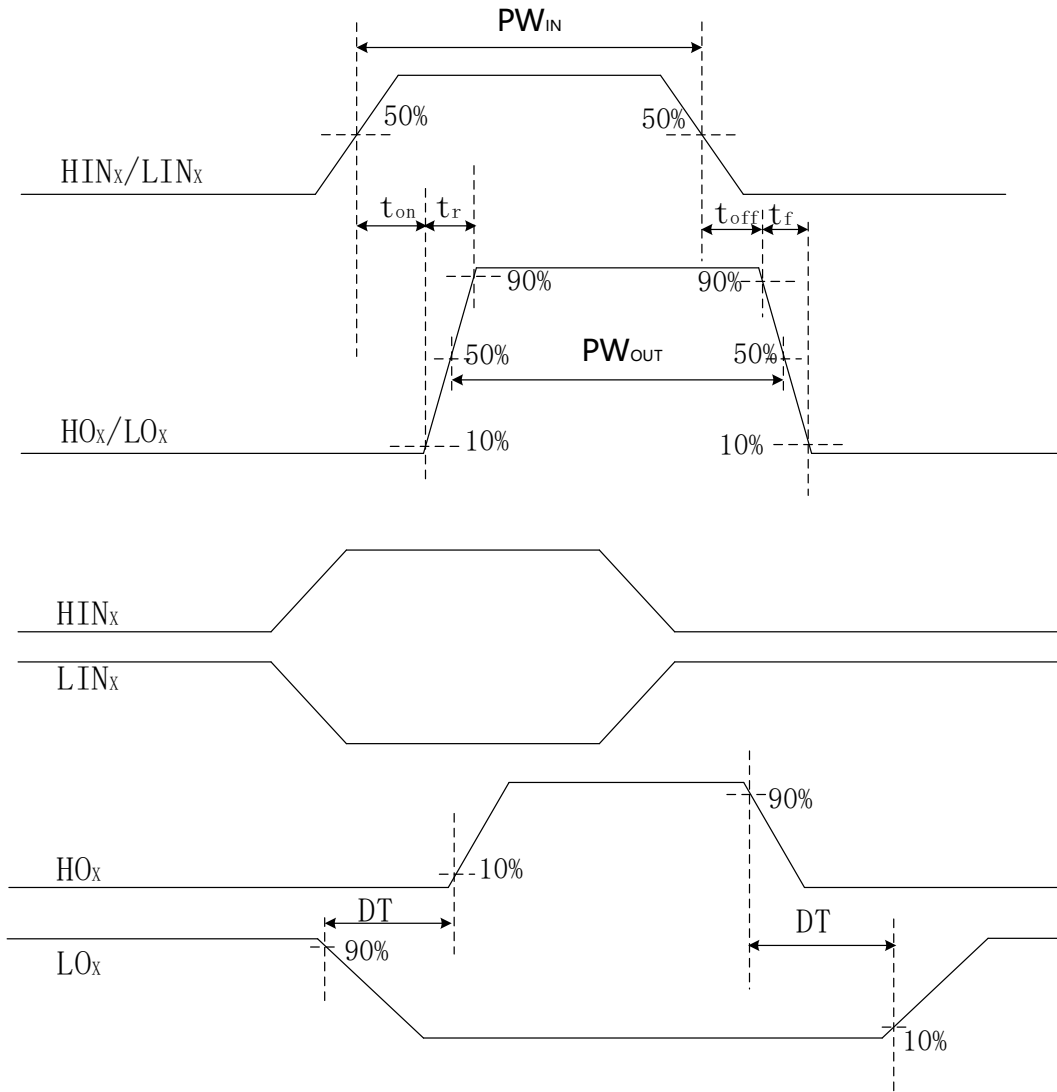

Figure 18 Switching and dead-Time timing state

Table 42 Gate driver electrical characteristics

Symbol	Description	Min	Typical	Max	Unit
IQCC	Static power supply current ($HIN=LIN=0V$)		300	400	μA
UVCCCT	VCC undervoltage triggering value	4.2	4.5	4.8	V
UVCCHYS	VCC hysteresis threshold		0.2		
UVBST	VVBS undervoltage triggering value	4	4.3	4.6	
UVBSHYS	VVBS hysteresis threshold		0.2		
VIH	High-level input voltage threshold	2.5			
VIL	Low-level input voltage threshold			0.8	
RINPD	Input pull-down resistance		200		$k\Omega$

Product Naming Rule

Symbol	Description	Min	Typical	Max	Unit
IIN+	Input bias current (HO=high)			35	uA
IIN-	Input bias current (HO=low)			2	
IQBS	VB static power supply current (HO=low)		100	120	
ISINK	Input current		1		A
ISOURCE	Output current		1.2		
VOH	High-level output voltage (IO=100mA)		0.6	0.9	V
VOL	Low-level output voltage (IO=100mA)		0.3	0.45	
tr	Output rise time		40	60	ns
tf	Output fall time		15	30	
tDT	Dead time		200		
ton	Turn-on delay time		150	300	
toff	Turn-off delay time		150	300	

Table 43 5V LDO

Symbol	Description	Min	Typical	Max	Unit
VREG5	Linear regulator and gate driver power supply output (IO=40 mA)	4.5	5	5.5	V
IREG5	Linear regulator current output		120		mA
VREG5,drop1	Dropout voltage 1 (1 mA ≤ IO ≤ 40 mA, VCC=12V)		100	200	mV
VREG5,drop2	Dropout voltage 2 (10V ≤ VCC ≤ 15V, IO=40 mA)		200	400	mV

6 Package Dimensions

6.1 Package QFN48

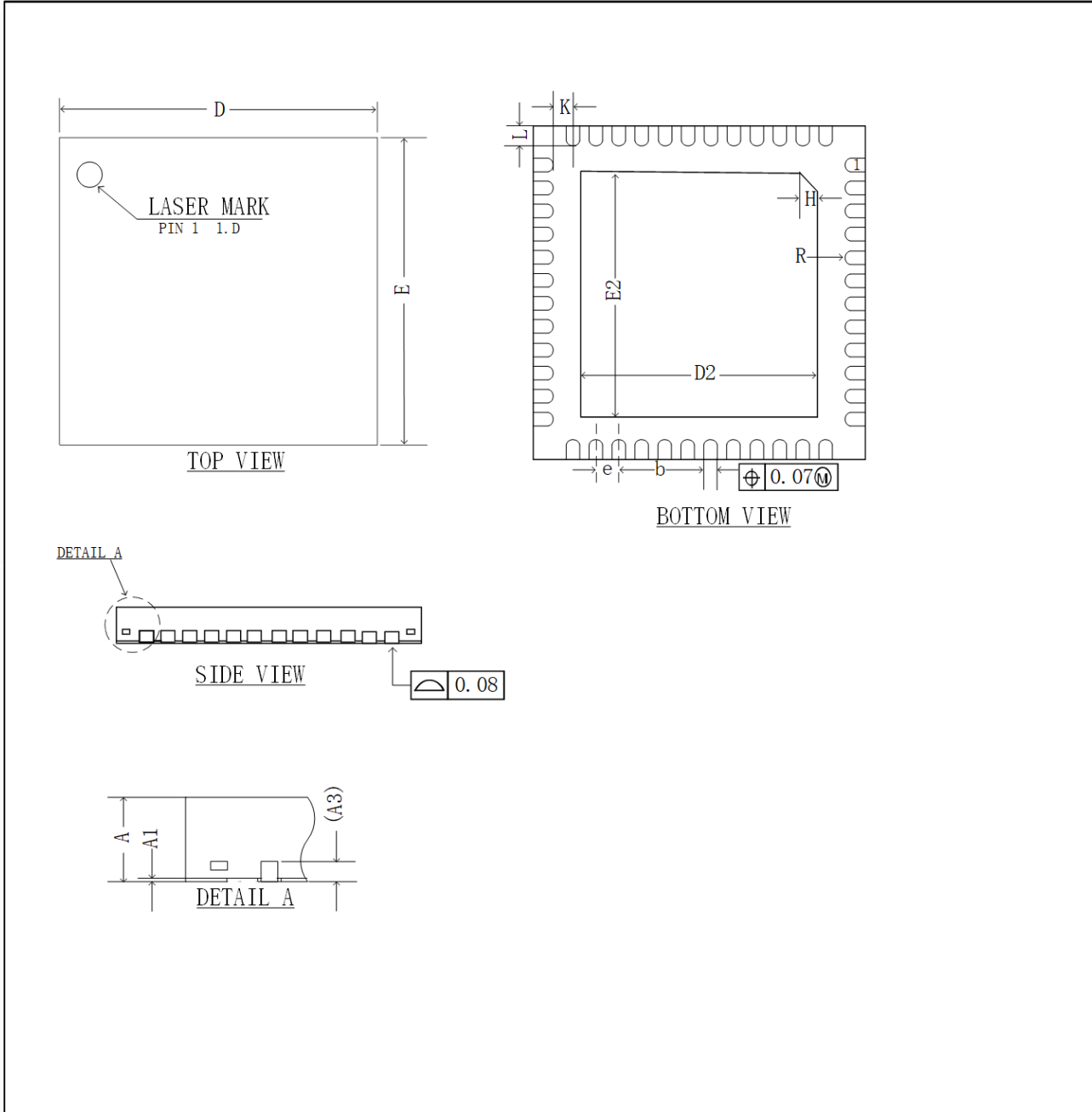

Figure 19 QFN48, 48-pin low-profile square flat package

1. Drawing is not to scale.
2. Dimensions are in millimeters.

Product Naming Rule

Table 44 QFN48 size description

Symbol	MM		
	Min	Typical	Max
A	0.70	0.75	0.80
A1	0.00	0.02	0.05
A3	0.203REF		
b	0.15	0.20	0.25
D	5.90	6.00	6.10
E	5.90	6.00	6.10
D2	4.30	4.40	4.50
E2	4.30	4.40	4.50
e	-	0.40	-
H	0.35REF		
K	0.30	0.40	0.50
L	0.30	0.40	0.50
R	0.075	-	-

6.2 Package QFN32

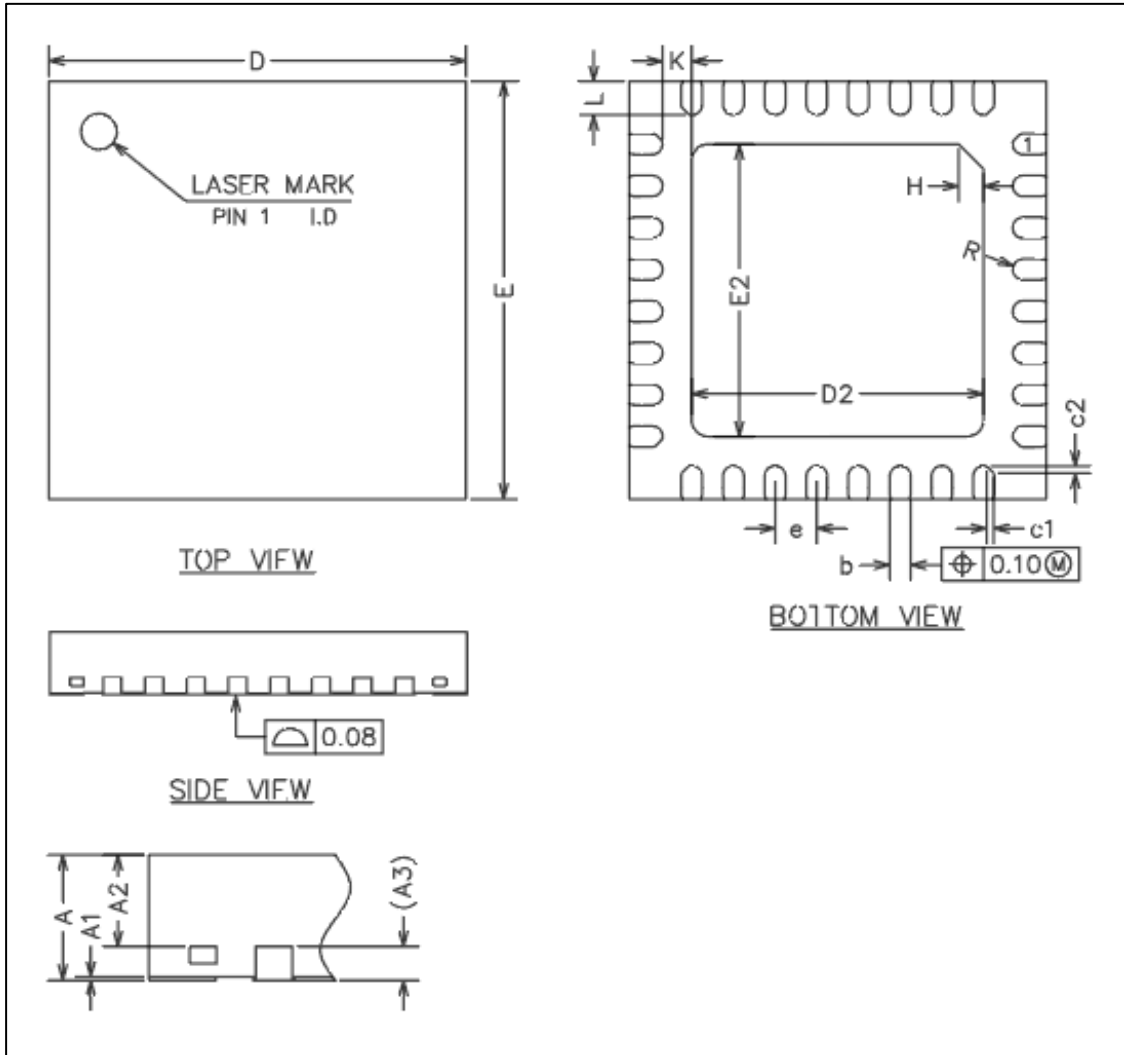

Figure 20 QFN32, 32-pin low-profile square flat package

1. Drawing is not to scale.
2. Dimensions are in millimeters.

Product Naming Rule

Table 45 QFN32 size description

Symbol	MM		
	Min	Typical	Min
A	0.70	0.75	0.80
A1	0.00	0.02	0.05
A2	0.50	0.55	0.60
A3	0.203REF		
b	0.18	0.23	0.28
D	4.90	5.00	5.10
E	4.90	5.00	5.10
D2	3.40	3.50	3.60
E2	3.40	3.50	3.60
e	-	0.5	-
H	0.30REF		
K	0.35REF		
L	0.35	0.40	0.45
R	0.09	-	-
c1	-	0.08	-
c2	-	0.08	-

7 Revision History

Date	Version	Content
2023/03/15	Rev0.1	First public release
2023/05/04	Rev0.5	Newly added electrical parameters
2023/06/07	Rev0.9	Newly added functional block diagram, ESD parameters updated
2024/01/02	Rev1.0	<ol style="list-style-type: none">1. Update package dimension information and Flash characteristic data.2. Add input voltage range information to the comparator characteristics table.3. Include input bias voltage conditions in the operational amplifier characteristics table.