

### Features

- Meets the Requirements of TIA/EIA- 232-F and ITU V.28 Standards
- Wide Power Supply Range: Single +3V to +5.5V
- Two Drivers and Two Receivers
- Operates up to 250 kbps
- Typically requires Four External 0.1 $\mu$ F Cap
- ESD Protection for RS-232 Bus Pins
  - ±15 kV (HBM)
  - ±12 kV (IEC61000-4-2, Contact Discharge)
  - ±15 kV (IEC61000-4-2, Air-Gap Discharge)

### Description

The TPT3232E is IEC61000 ESD protected, 3.0V to 5.5V powered transceivers that meet the RS-232 standards for balanced communication. Each receiver converts TIA/RS-232 inputs to TTL/CMOS levels.

The devices have a typical threshold of 1.25V, a typical hysteresis of 0.3V, and can accept  $\pm 15V$  inputs. The device operates at data signaling rates up to 250 kbps. The TPT3232E is available in SOP16, SSOP16 and TSSOP16 package, and is characterized from  $-40^{\circ}C$  to  $125^{\circ}C$ .

### Applications

- Battery-Powered Equipment
- Industry Human Machine Interface
- Notebook, Computers
- Printers

### Device Table

Device	Package	Body size
TPT3232E-SS3R	SSOP16	6.2 mm x 5.3 mm
TPT3232E-TS3R	TSSOP16	5.0 mm x 4.4 mm
TPT3232E-SO3R	SOP16	9.9 mm x 3.9 mm

### Function Block

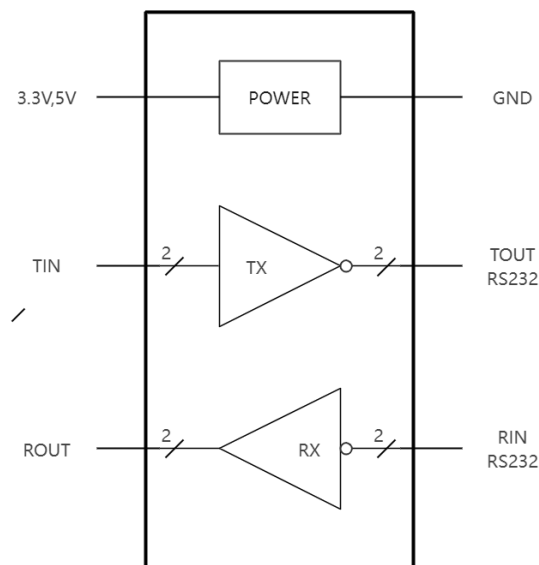

## Revision History

Date	Revision	Notes
2019/02/22	Rev. Prelim	Definition Draft
2020/02/18	Rev. A0	Released version
2020/04/24	Rev. B0	Updated C1~C4 recommended value
2023/11/16	Rev. C0	Added the disclaimer

## Order Information

Order Number	Operating Temperature Range	Package	Marking Information	MSL	Transport Media, Quantity
TPT3232E-SS3R	-40 to 125°C	SS3R 16-Pin SSOP	3232E	MSL3	Tape and Reel, 2000
TPT3232E-TS3R	-40 to 125°C	TS3R 16-Pin TSSOP	3232E	MSL3	Tape and Reel, 3000
TPT3232E-SO3R	-40 to 125°C	SO3R 16-Pin SOP	3232E	MSL3	Tape and Reel, 2500

## Pin Configuration and Functions

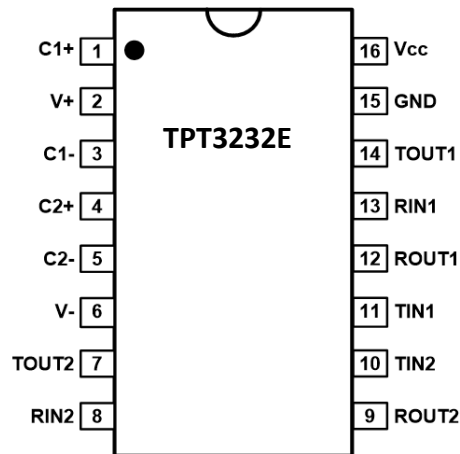

Pin No.	Symbol	I/O Type	Description
1	C1+		Positive lead of C1 capacitor
2	V+	Output	Positive charge pump output for storage capacitor only
3	C1-		Negative lead of C1 capacitor
4	C2+		Positive lead of C2 capacitor
5	C2-		Negative lead of C2 capacitor
6	V-	Output	Negative charge pump output for storage capacitor only
7	TOUT2	Output	Output of RS232 driver, RS232 level
8	RIN2	Input	Input of RS232 receiver, RS232 level
9	ROUT2	Output	Output of RS232 receiver, TTL/CMOS level
10	TIN2	Input	Input of RS232 driver, TTL/CMOS level
11	TIN1	Input	Input of RS232 driver, TTL/CMOS level
12	ROUT1	Output	Output of RS232 receiver, TTL/CMOS level
13	RIN1	Input	Input of RS232 receiver, RS232 level
14	TOUT1	Output	Output of RS232 driver, RS232 level
15	GND		Ground
16	V <sub>CC</sub>		Supply voltage

## Absolute Maximum Ratings

SYMBOL	DESCRIPTION	MIN	MAX	UNIT
V <sub>CC</sub>	Supply voltage	-0.3	6	V
V+	Positive output supply voltage	-0.3	7	V
V-	Negative output supply voltage	-7	0.3	V
V+ – V-	Supply voltage difference		13	V
TIN1, TIN2	Input voltage of driver, TTL/CMOS level	-0.3	6	V
TOUT1, TOUT2	Output voltage of driver, RS232 level	-13.2	13.2	V
RIN1, RIN2	Input voltage of receiver, RS232 level	-15	15	V
ROUT1, ROUT2	Output voltage of receiver, TTL/CMOS level	-0.3	V <sub>CC</sub> +0.3	V
T <sub>J</sub>	Operating virtual junction temperature		150	°C

(1) Stresses beyond the *Absolute Maximum Ratings* may cause permanent damage to the device. These are stress ratings only, which do not imply functional operation of the device at these or any other conditions beyond those indicated under *Recommended Operating Conditions*.

## Thermal Resistance

PART NUMBER	PACKAGE TYPE	$\theta_{JA}$	$\theta_{JC}$	UNIT
TPT3232E -SS3R	16-Pin SSOP	103	45	°C/W
TPT3232E -TS3R	16-Pin TSSOP	115	48	°C/W
TPT3232E -SO3R	16-Pin SOP	91	43	°C/W

## ESD Rating

		Value	UNIT
RS232 Bus Pin: TOUT1, TOUT2, RIN1, RIN2	HBM, Human body model	±15	kV
RS232 Bus Pin: TOUT1, TOUT2, RIN1, RIN2	IEC-61000-4-2, Contact Discharge	±12	kV
RS232 Bus Pin: TOUT1, TOUT2, RIN1, RIN2	IEC-61000-4-2, Air-Gap Discharge	±15	kV
All Pin except RS232 Bus Pin	HBM, Human body model	±6	kV
All Pin	CDM, Charge device model	±1.5	kV

## Electrical Characteristics

The following specifications apply for  $V_{CC} = 3.0V$  to  $3.6V$ ,  $4.5$  to  $5.5V$ ,  $C_1 - C_4 = 0.2\mu F$ ,  $T_A = -40^\circ C$  to  $125^\circ C$ , unless otherwise noted.

Parameter	Conditions	Min	Typ	Max	Units
<b>DC Characteristics</b>					
I <sub>CC</sub> = Supply Current	no load, V <sub>CC</sub> = 3.3V, T <sub>INx</sub> = GND or V <sub>CC</sub> , T <sub>A</sub> = 25°C		1.2	15	mA
<b>Logic Inputs and Receiver Outputs</b>					
Input Voltage of Logic Low	T <sub>IN1</sub> , T <sub>IN2</sub>			0.8	V
Input Voltage of Logic High	T <sub>IN1</sub> , T <sub>IN2</sub> , V <sub>CC</sub> = 3.3V	2			V
Input Voltage of Logic High	T <sub>IN1</sub> , T <sub>IN2</sub> , V <sub>CC</sub> = 5.0V	2.4			V
Input Leakage Current	T <sub>IN1</sub> , T <sub>IN2</sub> , V <sub>IN</sub> = 0V to V <sub>CC</sub> , T <sub>A</sub> = 25°C	-1		15	μA
Output Leakage Current	R <sub>out1</sub> , R <sub>out2</sub> , V <sub>CC</sub> =3.3V	-15		10	uA
Output Voltage Low	I <sub>OUT</sub> = -1.5mA			0.3	V
Output Voltage High	I <sub>OUT</sub> = 1.5mA	V <sub>CC</sub> -0.3			V
<b>Driver Outputs</b>					
Output Voltage Swing	R <sub>L</sub> = 3kΩ, T <sub>INx</sub> = GND	±5.0	±5.4		V
Output Resistance	V <sub>CC</sub> = V <sub>+</sub> = V <sub>-</sub> = 0V, T <sub>OUTx</sub> =+2V, <sup>note1</sup>	160	2.4M		Ω
Output Short-Circuit Current	V <sub>OUT</sub> = 0V	-60		60	mA
<b>Receiver Inputs</b>					
Input Threshold Low	V <sub>CC</sub> = 3.3V,	0.6	1.30		V
	V <sub>CC</sub> = 5.0V	0.8	1.30		
Input Threshold High	V <sub>CC</sub> = 3.3V,		1.60	2.4	V
	V <sub>CC</sub> = 5.0V		1.60	2.4	
Input Hysteresis	<sup>note1</sup>		0.3		V
Input Resistance	R <sub>IN</sub> voltage = 5V <sup>note1</sup>	3	5	7	kΩ
<b>Timing Characteristics</b>					
Maximum Data Rate	R <sub>L</sub> = 3kΩ, C <sub>L</sub> = 1000pF, one driver switching, <sup>Note1</sup>			250	kbps
Driver Propagation Delay, high to low output, t <sub>DPHL</sub>	Driver input to receiver output, C <sub>L</sub> = 150pF		700	1000	ns
Driver Propagation Delay, low to high output, t <sub>DPLH</sub>	Driver input to receiver output, C <sub>L</sub> = 150pF		500	700	ns
Driver Skew	t <sub>DPHL</sub> - t <sub>DPLH</sub>		200	400	ns
Transition-Region Slew Rate	V <sub>CC</sub> = 3.3V, R <sub>L</sub> = 3kΩ, C <sub>L</sub> = 1000pF, T <sub>A</sub> = 25°C, <sup>note1</sup>	6	10	30	V/μs
Receiver Propagation Delay, high to low output, t <sub>RPHL</sub>	Receiver input to receiver output, C <sub>L</sub> = 150pF		180	300	ns
Receiver Propagation Delay, low to high output, t <sub>RPLH</sub>	Receiver input to receiver output, C <sub>L</sub> = 150pF		210	400	ns
Receiver Skew	t <sub>RPHL</sub> - t <sub>RPLH</sub>		30	100	ns

Note1: based on Bench characterization and design simulation

Note2: I<sub>CC</sub> = 3mA with no load; and I<sub>CC</sub> = 15mA with max load, R<sub>L</sub> = 3kΩ, C<sub>L</sub> = 1000pF

### Parameter Measurement Information

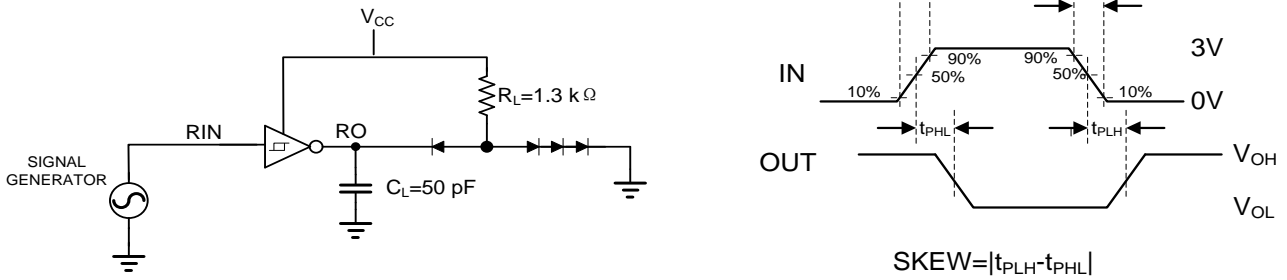

Figure 1 Receiver Propagation Delay and Receiver Skew

### Typical Application Circuit

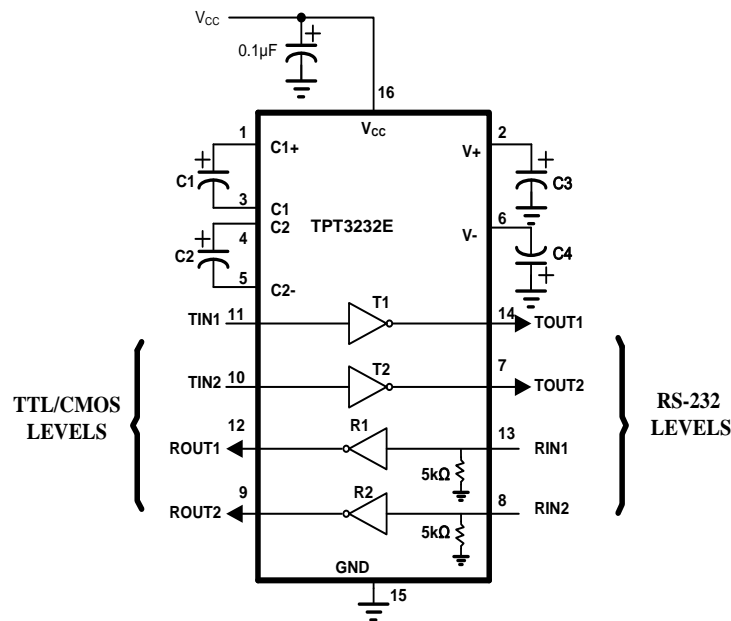

Figure 2 Typical application circuit

Non-polarized ceramic capacitors are acceptable. If polarized tantalum or electrolytic capacitors are used, they should be connected as shown in Figure 22. The recommended capacitor value of C1 to C4 is in Table 1. If the power supply is possibly connected to 3.3V or 5.5V, all cap as 0.2uF is suggested in the application.

V <sub>cc</sub> (V)	C1(μF)	C2, C3, C4(μF)
3.0 to 3.6	0.2	0.1
4.5 to 5.5	0.1	0.1
3.0 to 5.5	0.2	0.2

Table 1 Required Minimum Capacitor Values

### Tape and Reel Information

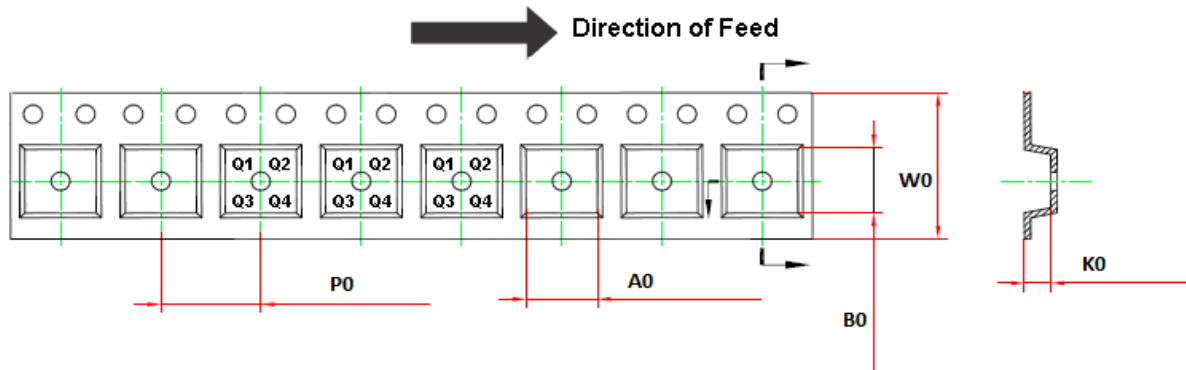
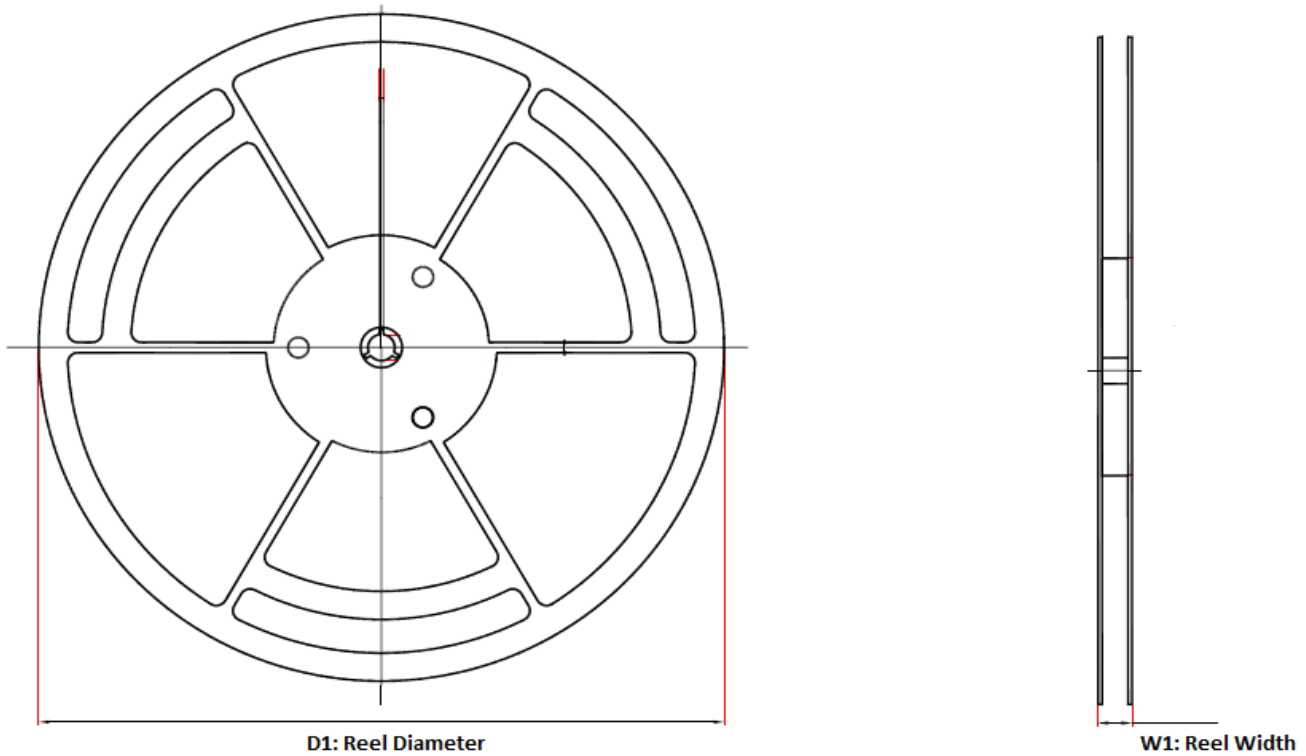

Order Number	Package	D1	W1	A0	B0	K0	P0	W0	Pin1 Quadrant
TPT3232E-SO3R	SOP16	330	21.6	6.7±0.1	10.4±0.1	2.1±0.1	8.0±0.1	16.0±0.3	Q1
TPT3232E-TS3R	TSSOP16	330	17.6	6.8±0.1	5.4±0.1	1.3±0.1	8.0±0.1	12.0±0.1	Q1
TPT3232E-SS3R	SSOP16	330	21.6	8.5	6.8	2.37	12.00	16.00	Q1

Package Outline Dimensions

SS3R (SSOP16)

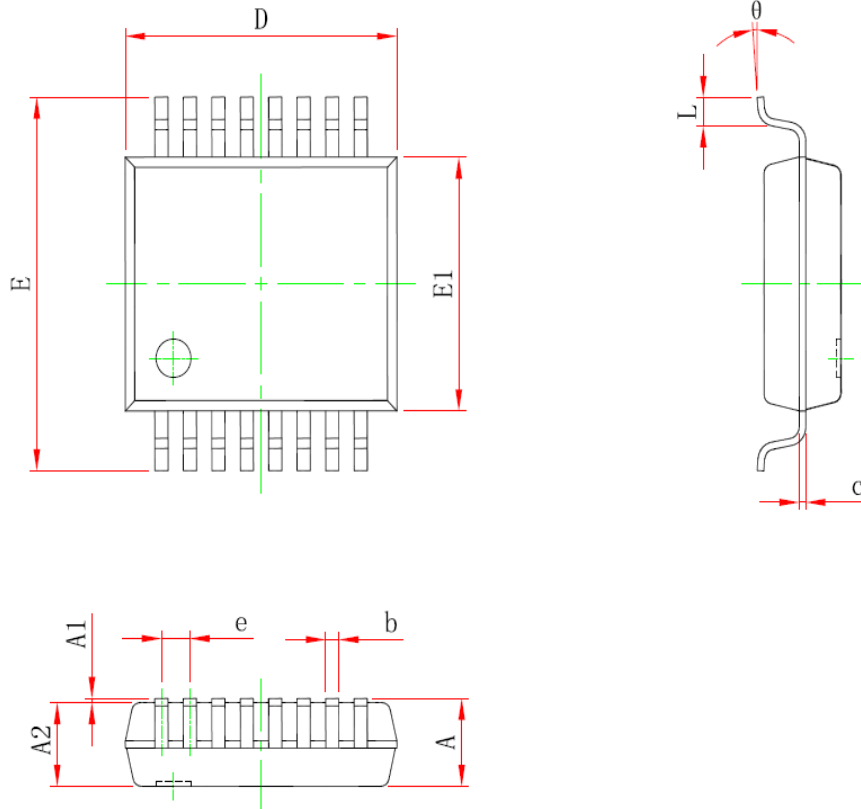

Symbol	Dimensions In Millimeters		Dimensions In Inches	
	Min	Max	Min	Max
A	--	2.000	--	0.079
A1	0.050	--	0.002	--
A2	1.650	1.850	0.065	0.073
b	0.220	0.380	0.009	0.015
c	0.090	0.250	0.004	0.010
D	5.900	6.500	0.232	0.256
E	7.400	8.200	0.291	0.323
E1	5.000	5.600	0.197	0.220
e	0.650 (BSC)		0.026 (BSC)	
L	0.550	0.950	0.022	0.037
theta	0°	8°	0°	8°

**TS3R (TSSOP16)**

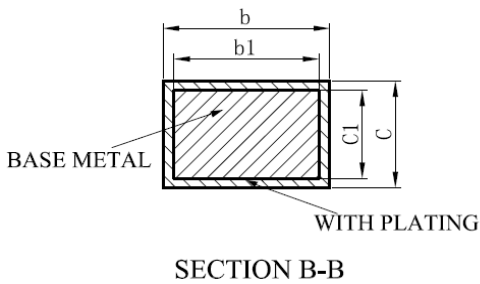
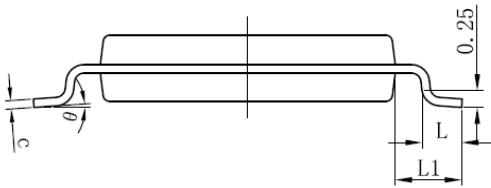
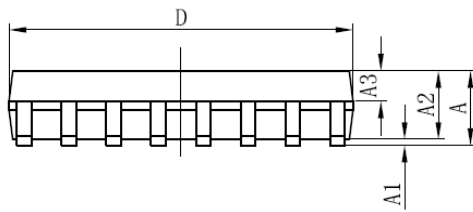
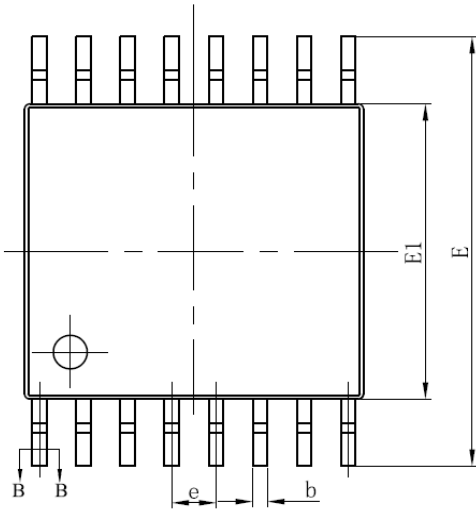

SYMBOL	MILLIMETER		
	MIN	NOM	MAX
A	—	—	1.20
A1	0.05	—	0.15
A2	0.90	1.00	1.05
A3	0.39	0.44	0.49
b	0.20	—	0.28
b1	0.19	0.22	0.25
c	0.13	—	0.17
c1	0.12	0.13	0.14
D	4.90	5.00	5.10
E	6.20	6.40	6.60
E1	4.30	4.40	4.50
e	0.65BSC		
L	0.45	0.60	0.75
L1	1.00BSC		
0	0	—	8°

SO3R (SOP16)

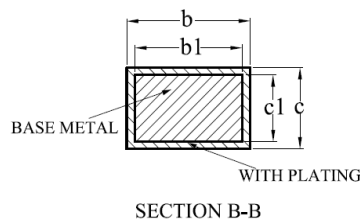
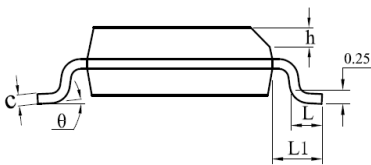
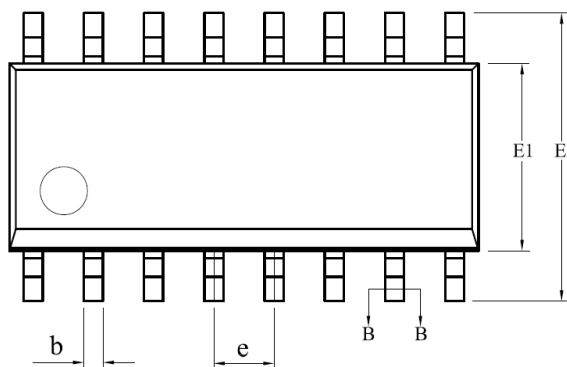
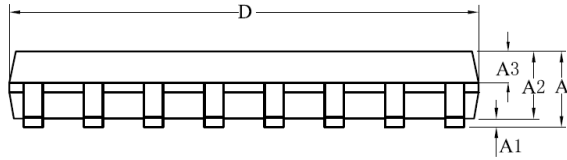

SYMBOL	MILLIMETER		
	MIN	NOM	MAX
A	—	—	1.75
A1	0.10	—	0.225
A2	1.30	1.40	1.50
A3	0.60	0.65	0.70
b	0.39	—	0.47
b1	0.38	0.41	0.44
c	0.20	—	0.24
c1	0.19	0.20	0.21
D	9.80	9.90	10.00
E	5.80	6.00	6.20
E1	3.80	3.90	4.00
e	1.27BSC		
h	0.25	—	0.50
L	0.50	—	0.80
L1	1.05REF		
θ	0	—	8°

## Important Notice

**Copyright**© 3PEAK 2012-2023. All rights reserved.

**Trademarks.** Any of the 思瑞浦 or 3PEAK trade names, trademarks, graphic marks, and domain names contained in this document /material are the property of 3PEAK. You may NOT reproduce, modify, publish, transmit or distribute any Trademark without the prior written consent of 3PEAK.

**Performance Information.** Performance tests or performance range contained in this document/material are either results of design simulation or actual tests conducted under designated testing environment. Any variation in testing environment or simulation environment, including but not limited to testing method, testing process or testing temperature, may affect actual performance of the product.

**Disclaimer.** 3PEAK provides technical and reliability data (including data sheets), design resources (including reference designs), application or other design recommendations, networking tools, security information and other resources "As Is". 3PEAK makes no warranty as to the absence of defects, and makes no warranties of any kind, express or implied, including without limitation, implied warranties as to merchantability, fitness for a particular purpose or non-infringement of any third-party's intellectual property rights. Unless otherwise specified in writing, products supplied by 3PEAK are not designed to be used in any life-threatening scenarios, including critical medical applications, automotive safety-critical systems, aviation, aerospace, or any situations where failure could result in bodily harm, loss of life, or significant property damage. 3PEAK disclaims all liability for any such unauthorized use.