



深圳市矽源特科技有限公司
ShenZhen ChipSoureTek Technology Co.,Ltd.

DATASHEET

CST510P8

Self-capacitive touch controller

Version: 1.0
2023.02.09



GENERAL DESCRIPTION

CST510P8 is a high-performance self-capacitor touch key controller that supports various self-capacitor key, slider or scroll wheel patterns and has excellent signal-to-noise ratio to achieve high reliability while maintaining ultra-low power consumption. CST510P8 also supports LED dimming control base on PWM.

1 CST510P8 Features

1.1 Key features

◆ Touch controller

- Support key number up to 14
- Support sliders/scroll wheel
- Support three work modes: Normal mode, Idle mode, Sleep mode
- The sleep mode power consumption is as low as 5uA, and the normal mode power consumption is as low as 2mA
- Auto calibration
- Support I2C interfaces
- Support online programming

◆ PWM

- 8 PWM LED/Output drivers
- Hardware PWM set through I2C memory map – no overhead from host
- Dimming mode available, up and down
- Minimum, maximum & adjustable limit levels for dimming mode

◆ Single power supply 2.7V to 5.5V

◆ Package: QFN24 3x3x0.55mm

◆ Applications

- Household appliances, small appliances
- Intelligent switch
- Office equipment, toys
- Test equipment



1.2 Pin layout

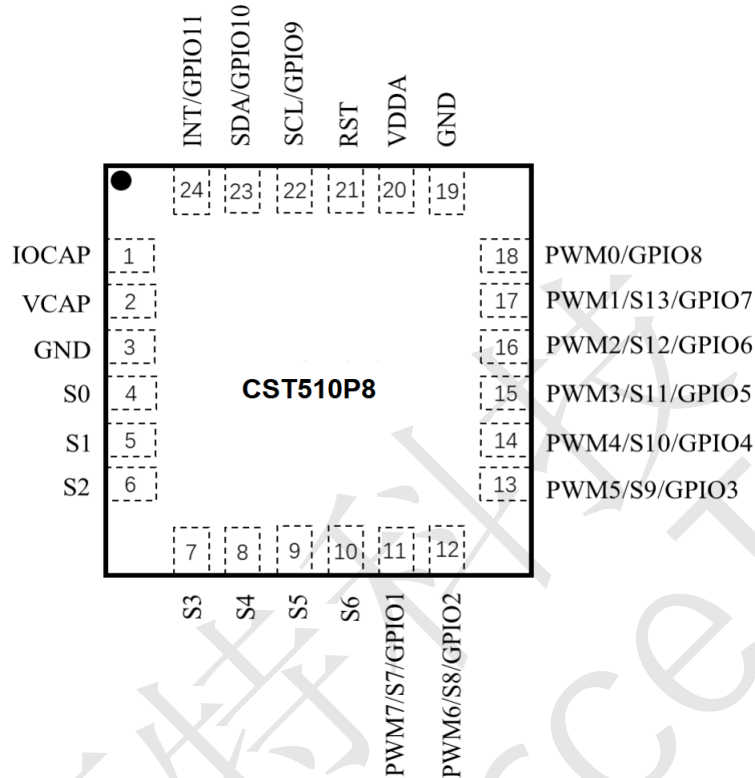

PIN NO.	PIN Name	Description
1	IOCAP	Connect 1uF capacitor
2	VCAP	Connect 1uF capacitor
3	GND	Supply Ground
4~10	S0~S6	Sensor channels
11	PWM7/ S7/GPIO1	PWM output, also can be reused as sensor channel or GPIO
12	PWM6/S8/GPIO2	PWM output, also can be reused as sensor channel or GPIO
13	PWM5/S9/GPIO3	PWM output, also can be reused as sensor channel or GPIO
14	PWM4/S10/GPIO4	PWM output, also can be reused as sensor channel or GPIO
15	PWM3/S11/GPIO5	PWM output, also can be reused as sensor channel or GPIO
16	PWM2/S12/GPIO6	PWM output, also can be reused as sensor channel or GPIO
17	PWM1/S13/GPIO7	PWM output, also can be reused as sensor channel or GPIO
18	PWM0/GPIO8	PWM output, also can be reused as GPIO
19	GND	Supply Ground
20	VDDA	Power supply 2.7~5.5V, connect 1-10uF capacitor
21	RESET	Reset input, active low
22	SCL/GPIO9	I2C clock input, also can be reused as GPIO
23	SDA/GPIO10	I2C data input and output, also can be reused as GPIO
24	INT/GPIO11	Interrupt output, also can be reused as GPIO External interrupt to the host



2 CST510P8 Function Overview

2.1 Block diagram

The overall system block diagram of the CST510P8 is shown as Figure below.

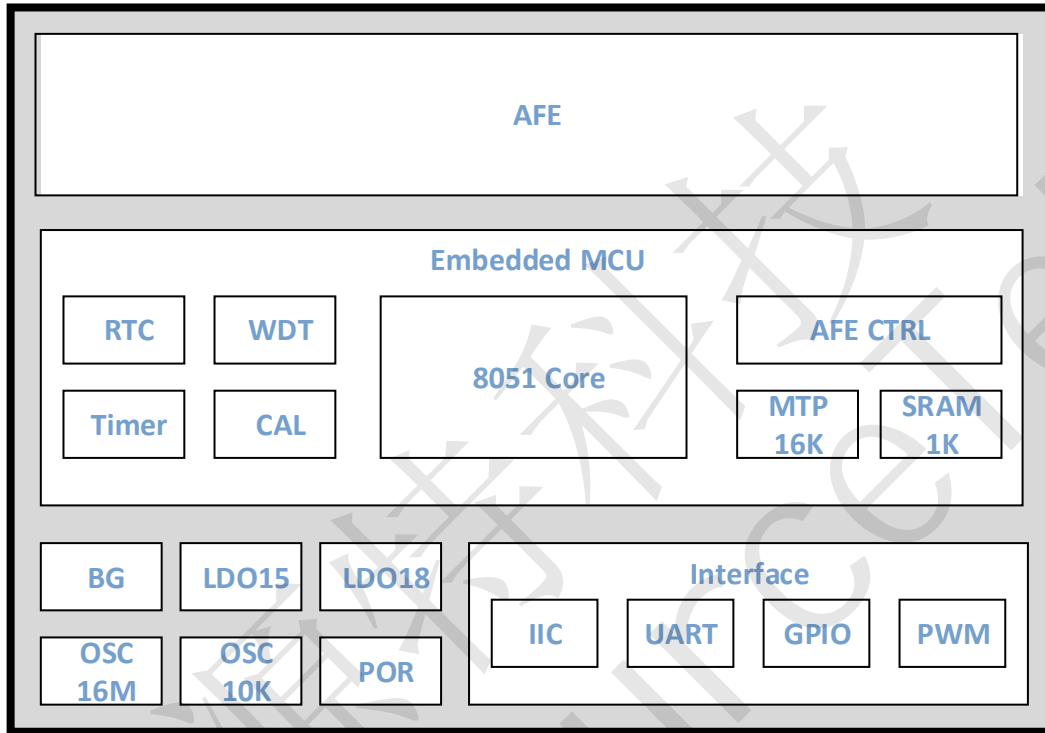

Figure: block diagram

2.1.1 AFE

AFE channels connect with key patterns, scan by sending AC signals to the patterns and process the received signals, which finally be converted by ADC and sent to MCU.

2.1.2 Interface

IIC is main communication interface which support slave mode only and support up to 400KHz transfer speed. Detail of IIC communication please refer to Chapter 3.

UART is normally used as debug function. It supports up to 1Mbps baud.

GPIO1~8 high level voltage is VDDA, GPIO9~11 (pins: “INT”, “SDA”, “SCL”) high level voltage can be configured to 1.8V or VDDA by setting internal register. “INT” signal is used to inform HOST to get newest key states or just wakeup HOST. Each GPIO supports external interrupt, can be independently configured select the trigger event(rising edge, falling edge, high level or low level) and can be masked independently.



PWM module provides 8 channels, and the range of period can be set from 130ns to 65.52ms. Each channel shares the same period but uses independent duty cycle. The minimum duty cycle adjustment step is 0.0625 us.

2.1.3 Embedded MCU

Embedded MCU bases on a high efficiency core.

MTP is used to store firmware and run.

SRAM is for system use.

AFE CTRL module is the interface between MCU and AFE. User can configurate AFE CTRL registers to generate control signals to AFE. AFE also inform MCU current state through AFE CTRL module.

RTC works with OSC2. It is used to support low-power scan mode, in which OSC1 can be shut down and AFE scan is triggered automatically.

CAL module is designed for speeding up data process.

Timer can be used to generate a precise latency.

WDT is used to ensure the stability of chip when in operation.

Signal processing algorithms are implemented by MCU to detect the key states reliably and efficiently. Communication protocol is also implemented by MCU to exchange key states or control information with HOST.

2.2 Work modes

There are three work modes available:

- Normal mode
- Idle mode
- Sleep mode

Work modes switching conditions are shown as below:

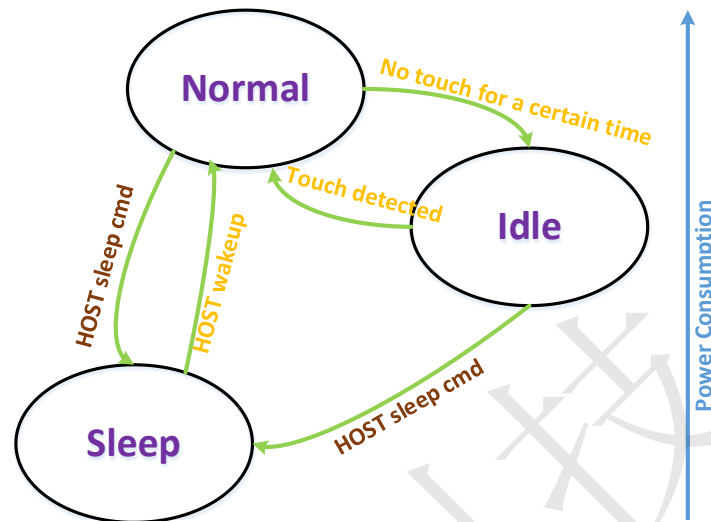

Figure: Work modes

2.2.1 Normal mode

In normal mode, AFE scans the key patterns in a configurable scan-rate, MCU will detect touch states of each key and report.

2.2.2 Idle mode

When there is no touch on any key for a configurable interval, MCU automatically switch into idle mode. In idle mode, AFE scans the key patterns with a relatively lower scan-rate (also configurable) to reduce power consumption. Majority of the algorithms will be canceled, and only simple detection algorithms is retained to detect if there is a touch. Once a touch on any key is detected, MCU will immediately switch back to normal mode.

2.2.3 Sleep mode

In sleep mode, MCU enters ultra low-power mode and can be wakeup by IIC. The power consumption in this mode is extremely small, can greatly extend the standby time of portable devices.



3 CST510P8 Communication Interface

The connection from host to CST510P8 is shown as below:

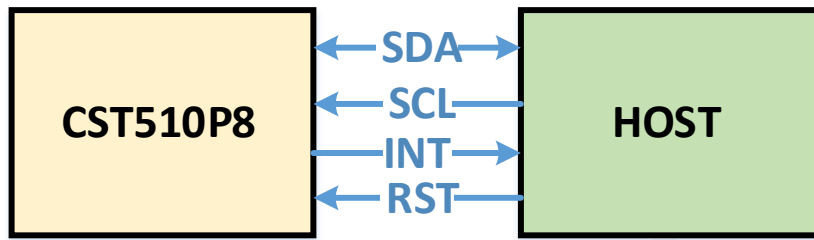

Figure: interface

INT signal is used to inform HOST that there are touch events and touch information is ready. INT signal idle level can be configured as low or high. When there are touch events, INT signal is set to active level until HOST read the touch information. If HOST haven't read the touch information, INT signal would retain active level until next touch events update. So, HOST can use either level or edge trigger-mode interrupt to respond INT signal.

RST signal is used to reset CST510P8 by setting low level for a while then setting back to high level.

IIC interface is used to transfer data between CST510P8 and HOST. Write/Read protocols are shown as below:



Figure: IIC write/Read operation



Figure: Host write CST510P8 register

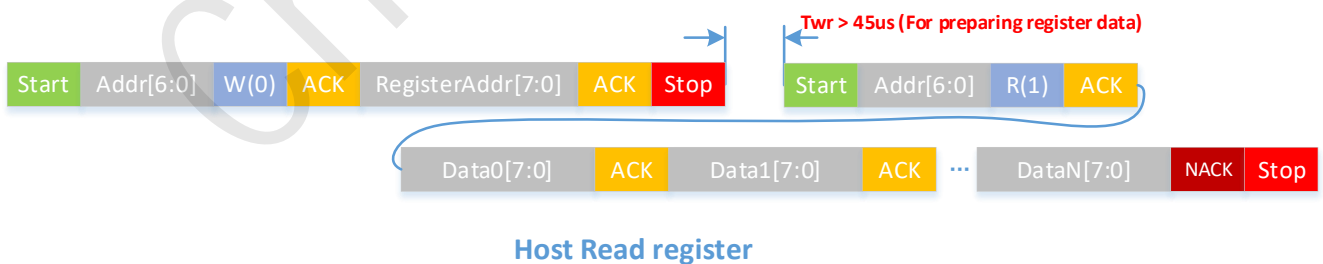

Figure: Host read CST510P8 register



4 CST510P8 Electrical Specifications

4.1 Absolute maximum ratings

Table: Absolute Maximum Ratings

Characteristics	Sym.	Min.	Max	Unit	Test Condition
Supply Voltage	VDDA	-0.3	5.5	V	
Storage temperature Range	T _{St}	-55	150	°C	

4.2 Recommended operating condition

Table: Recommended operation condition

Item	Sym.	Min	Typ.	Max	Unit	Condition
Power-supply voltage	VDDA	2.7	3.3	5.5	V	
Operating Temperature Range	T _{Opr}	-40		85	°C	

4.3 AC characteristics

Table: AC Characteristics

Parameter	Sym.	Min	Typ.	Max	Unit	Condition
Digital inputs/outputs						
Input high voltage	V _{IH}	0.7 × IOVCC		IOVCC	V	
Input low voltage	V _{IL}	GND		0.3 × IOVCC	V	
Output high voltage	V _{OH}	0.7 × IOVCC		IOVCC	V	
Output low voltage	V _{OL}	GND		0.3 × IOVCC	V	

NOTE: IOVCC=VDDA or 1.8V



5 CST510P8 Schematic circuit

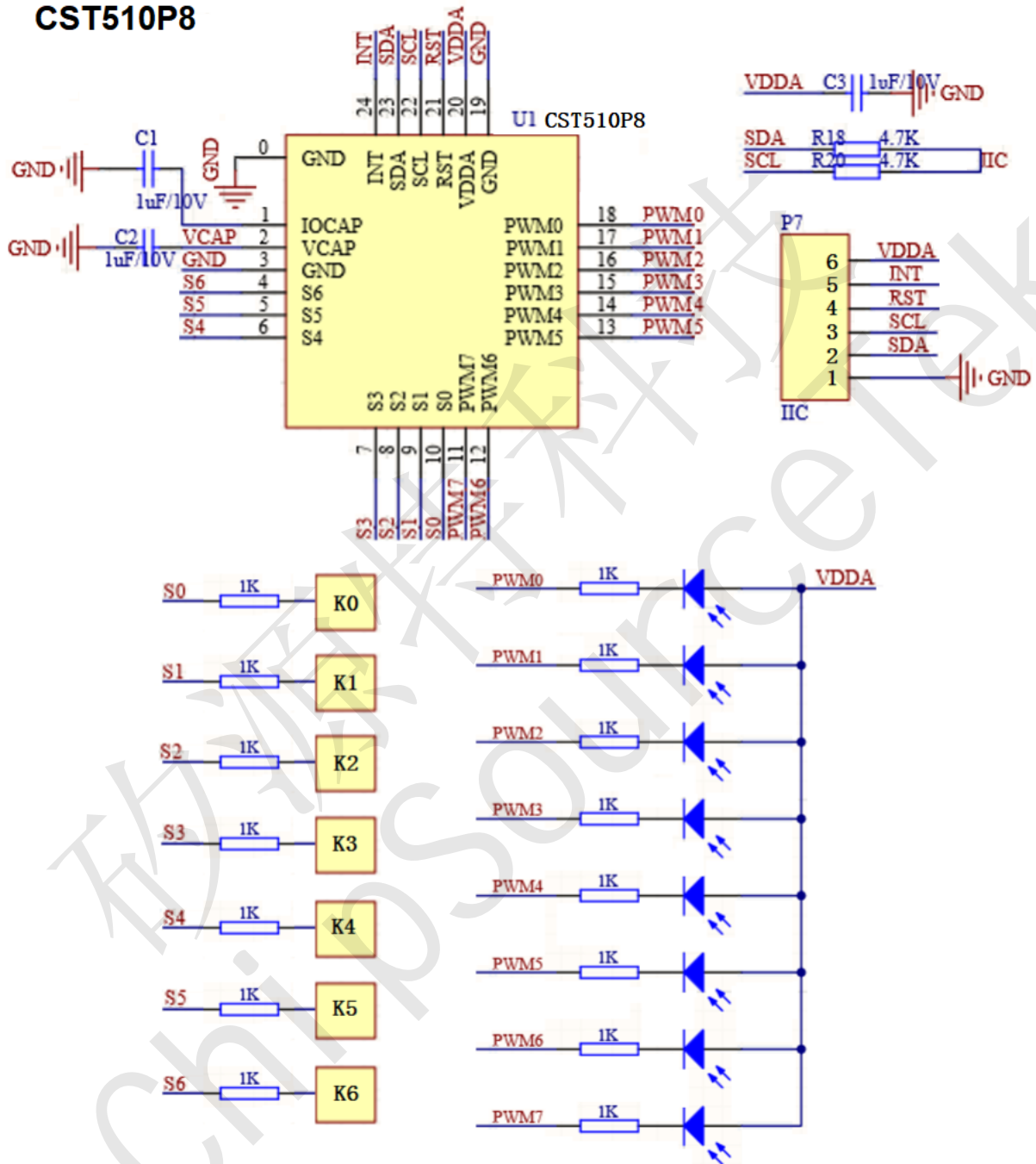

1. SDA、SCL芯片为开漏，需要HOST端接上拉电阻（电阻2.2KΩ~10KΩ）
2. PCB的Sensor 通道走线背面需要铺地铜隔离干扰



6 CST510P8 Package

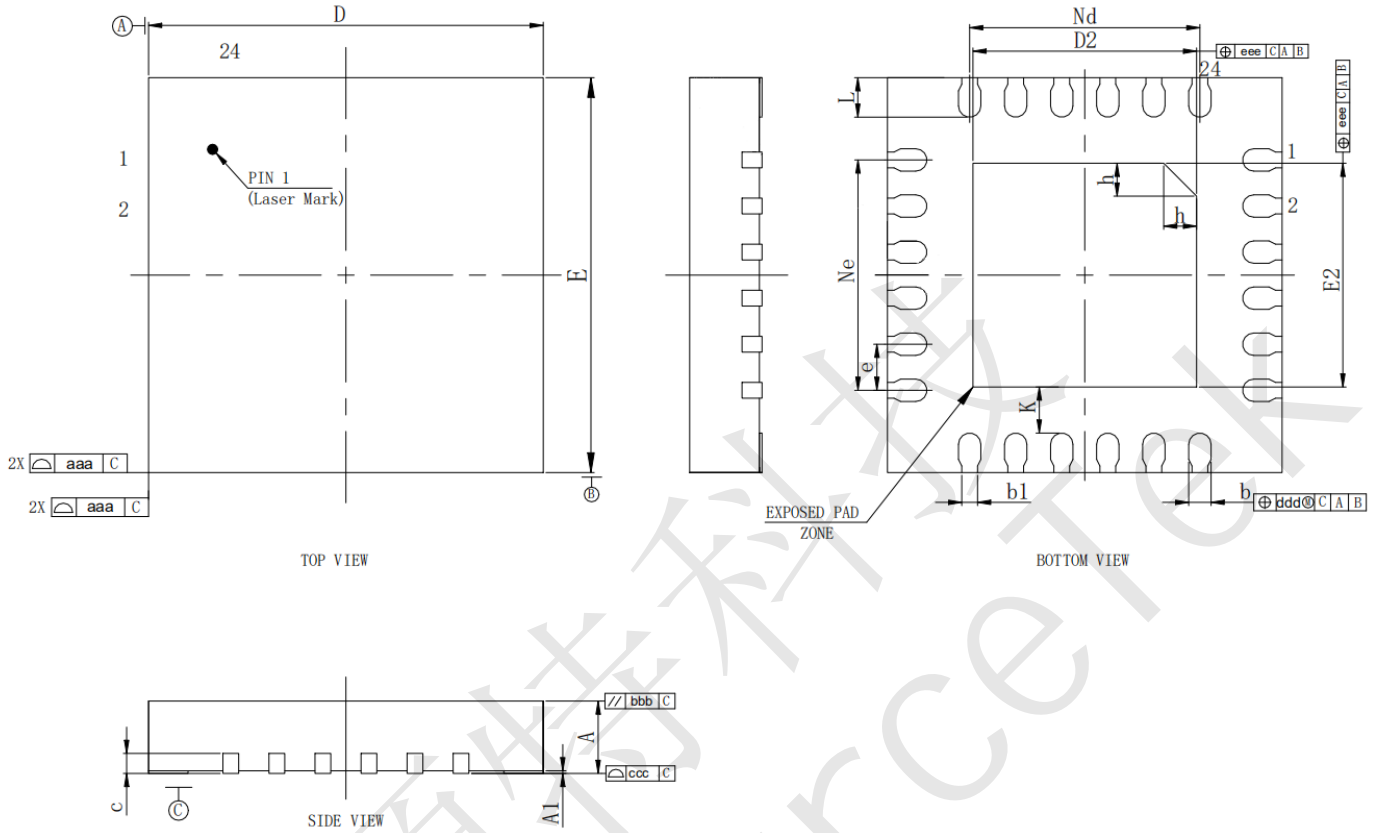

	SYMBOL	MILLIMETER			
		MIN	NOM	MAX	
TOTAL THICKNESS	A	0.50	0.55	0.60	
STAND OFF	A1	0	0.02	0.05	
LEAD WIDTH	b	0.12	0.17	0.22	
LEAD END WIDTH	b1	0.12REF			
L/F THICKNESS	c	0.152REF			
BOOY SIZE	X	D	2.90	3.00	3.10
	Y	E	2.90	3.00	3.10
LEAD PITCH	e	0.35BSC			
EP SIZE	X	D2	1.60	1.70	1.80
	Y	E2	1.60	1.70	1.80
ACCUMULATIVE PITCH	X	Nd	1.75BSC		
	Y	Ne	1.75BSC		
LEAD LENGTH	L	0.25	0.30	0.35	
SPACING BETWEEN LEAD EDGE TO E-PAD EDGE	K	0.35REF			
PIN 1# ID	h	0.20	0.25	0.30	
PACKAGE EDGE TOLERANCE	aaa	0.10			
MOLD FLATNESS	bbb	0.10			
COPLANARITY	ccc	0.08			
LEAD OFFSET	ddd	0.10			
EXPOSED PAD OFFSET	eee	0.10			



7 CST510P8 Ordering information

Product Series	Package Type	Packing Method	Ordering Number	Minimum Order Quantity
CST510P8	24-pin 3x3x0.55mm QFN	TR	CST510P8	3000

8 CST510P8 DISCLAIMER

The information appearing in this publication is believed to be accurate.

Integrated circuits sold by ChipSourceTek covered by the warranty and patent indemnification provisions stipulated in the terms of sale only. ChipSourceTek Technology makes no warranty, express, statutory implied or by description regarding the information in this publication or regarding the freedom of the described chip(s) from patent infringement. Furthermore, ChipSourceTek Technology makes no warranty of merchant ability or fitness for any purpose. ChipSourceTek Technology reserves the right to halt production or alter the specifications and prices at any time without notice. Accordingly, the reader is cautioned to verify that the data sheets and other information in this publication are current before placing orders. Products described herein are intended for use in normal commercial applications. Applications involving unusual environmental or reliability requirements, e.g. military equipment or medical life support equipment, are specifically not recommended without additional processing by ChipSourceTek Technology for such applications. Please note that application circuits illustrated in this document are for reference purposes only.