

**UV ERASABLE 32,768-BIT
READ ONLY MEMORY**

DESCRIPTION

The Fujitsu MBM2732A is a high speed 32,768-bit static N-channel MOS erasable and electrically re-programmable read only memory (EPROM). It is especially well suited for applications where rapid turn-around and/or bit pattern experimentation are important.

The MBM2732A is fabricated using N-channel double polysilicon gate technology with single transistor stacked gate cells. It is organized as 4096 words by 8-bits

for use in microprocessor applications. Single +5V operation greatly facilitates its use in systems.

A 24-pin dual in-line package with a transparent lid is used to package the MBM2732A. The transparent lid allows the user to expose the device to ultraviolet light in order to erase the memory bit pattern previously programmed. At the completion of erasure, a new pattern can then be written into the memory.

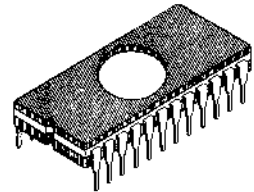

**CERDIP PACKAGE
DIP-24C-C02**

FEATURES

- Organized as 4096 words by 8-bits, fully decoded
- Simple programming requirements
- Single location programming
- Programs with one 50ms pulse
- Programming Voltage:
MBM2732A-20/-25/-30: 21 volts
MBM2732A-35/-35X: 21 or 25 volts
- Low power requirement:
MBM2732A-20/-25/-30:
Active: 780mW
Standby: 184mW
MBM2732A-35/-35X:
Active: 825mW
Standby: 165mW
- Single +5V operation
- MBM2732A-35X: Extended temperature range of -40°C to +85°C
- TTL compatible inputs and outputs
- No clocks required, fully static operation
- Three-state output with OR-tie capability
- Output Enable (\overline{OE}) pin for simplified memory expansion
- Fast Access Time:
MBM2732A-20 200 ns max.
MBM2732A-25 250 ns max.
MBM2732A-30 300 ns max.
MBM2732A-35 350 ns max.
MBM2732A-35X 350 ns max.
- Standard 24-pin DIP package
- Pin compatible with Intel 2732A

PIN ASSIGNMENT

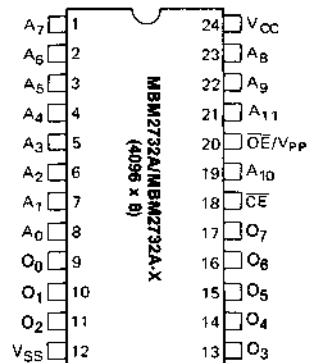

**MBM2732A
BLOCK DIAGRAM**

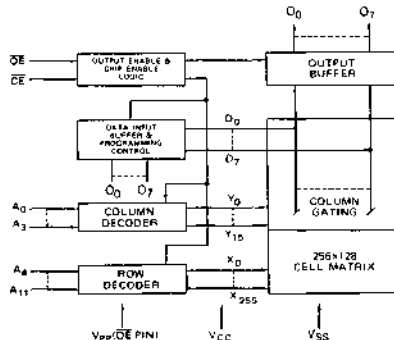

This device contains circuitry to protect the inputs against damage due to high static voltages or electric fields. However, it is advised that normal precautions be taken to avoid application of any voltage higher than maximum rated voltages to this high impedance circuit.

ABSOLUTE MAXIMUM RATINGS (See Note)

Rating		Symbol	Value	Unit
Temperature Under Bias		T_A	-25 to +85	°C
Storage Temperature	MBM2732A-20/-25/-30/-35	T_{stg}	-85 to +125	°C
	MBM2732A-35X		-50 to +95	
Inputs/Outputs (Except \overline{OE}/V_{PP}) with Respect to V_{SS}		V_{IN}, V_{OUT}	-0.6 to +7	V
Output Enable/Program Input with Respect to V_{SS}		\overline{OE}/V_{PP}	-0.6 to +26	V
V_{CC} with Respect to V_{SS}		V_{CC}	-0.6 to +7	V

NOTE: Permanent device damage may occur if ABSOLUTE MAXIMUM RATINGS are exceeded. Functional operation should be restricted to the conditions as detailed in the operations sections of this data sheet. Exposure to absolute maximum rating conditions for extended periods may affect device reliability.

FUNCTIONS AND PIN CONNECTIONS $V_{CC}(24) = +5, V_{SS}(12) = GND$

Function (Pin No.)	Address Input (1-8, 19, 21-23)	Data I/O (9-11, 13-17)	\overline{CE} (18)	\overline{OE}/V_{PP} (20)	I_{CC} Supply (24)
Read	A_{IN}	D_{OUT}	V_{IL}	V_{IL}	I_{CC2}
Output Disable	A_{IN}	High Z	V_{IL}	V_{IH}	I_{CC2}
Stand By	Don't Care	High Z	V_{IH}	Don't Care	I_{CC1}
Program	A_{IN}	D_{IN}	V_{IL}	V_{PP}	I_{CC2}
Program Verify	A_{IN}	D_{OUT}	V_{IL}	V_{IL}	I_{CC2}
Program inhibit	Don't Care	High Z	V_{IH}	V_{PP}	I_{CC1}

RECOMMENDED OPERATING CONDITIONS

(Referenced to V_{SS})

Parameter	Symbol	Min	Typ	Max	Unit	Operating Temperature	
						MBM2732A	MBM2732A-35X
Supply Voltage(1)	V_{CC}	4.75	5.0	5.25	V	0°C to +70°C	-40°C to +85°C
		-35/-35X	4.5	5.0			
Supply Voltage	V_{SS}	—	GND	—	V		
Input High Voltage	V_{IH}	2.0	—	$V_{CC} + 1$	V		
Input Low Voltage	V_{IL}	-0.1	—	0.8	V		

Note: (1) V_{CC} must be applied either before or coincident with V_{PP} and removed either after or coincident with V_{PP} .

CAPACITANCE

($T_A = 25^\circ\text{C}; f = 1\text{MHz}$)

Parameter	Symbol	Min	Typ	Max	Unit
Input Capacitance (Except $\overline{OE}/V_{PP}, V_{IN} = 0V$)	C_{IN1}	—	4	6	pF
\overline{OE}/V_{PP} Input Capacitance ($V_{IN} = 0V$)	C_{IN2}	—	—	20	pF
Output Capacitance ($V_{OUT} = 0V$)	C_{OUT}	—	8	12	pF

DC CHARACTERISTICS

(Recommended operating conditions unless otherwise noted)

Parameter	Symbol	Min	Typ	Max	Unit
Input Load Current ($V_{IN} = 5.25V$)	I_{LI}	—	—	10	μA
Output Leakage Current ($V_{OUT} = 5.25V$)	I_{LO}	—	—	10	μA
V_{CC} Supply Current (Standby) -20/-25/-30	I_{CC1}	—	—	35	mA
V_{CC} Supply Current (Active)	I_{CC2}	—	—	150	mA
V_{CC} Supply Current (Standby) -35/-35X	I_{CC3}	—	—	30	mA
Output Low Voltage ($I_{OL} = 2.1\text{mA}$)	V_{OL}	—	—	0.45	V
Output High Voltage ($I_{OH} = -400\mu\text{A}$)	V_{OH}	2.4	—	—	V

MBM2732A

AC TEST CONDITIONS (Including Programming)

Input Pulse Levels:	0.8V to 2.2V
Input Rise and Fall Time:	$\leq 20\text{ns}$
Timing Measurement Reference Levels:	1.0V and 2.0V for inputs 0.8V and 2.0V for outputs
Output Load:	1 TTL gate and $C_L = 100\text{pF}$

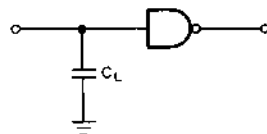

AC CHARACTERISTICS

(Recommended operating conditions unless otherwise noted)

Parameter	Symbol	MBM2732A-20		MBM2732A-25		MBM2732A-30		MBM2732A-35 MBM2732A-35X		Unit
		Min	Max	Min	Max	Min	Max	Min	Max	
Address Access Time	t_{ACC}	—	200	—	250	—	300	—	350	ns
Chip Enable to Output Delay	t_{CE}	—	200	—	250	—	300	—	350	ns
Output Enable to Output Delay	t_{OE}	10	70	10	100	10	150	—	120	ns
Address to Output Hold	t_{OH}	0	—	0	—	0	—	0	—	ns
Output Enable High to Output Float	t_{DF}	0	60	0	90	0	130	0	100	ns

OPERATION TIMING DIAGRAM

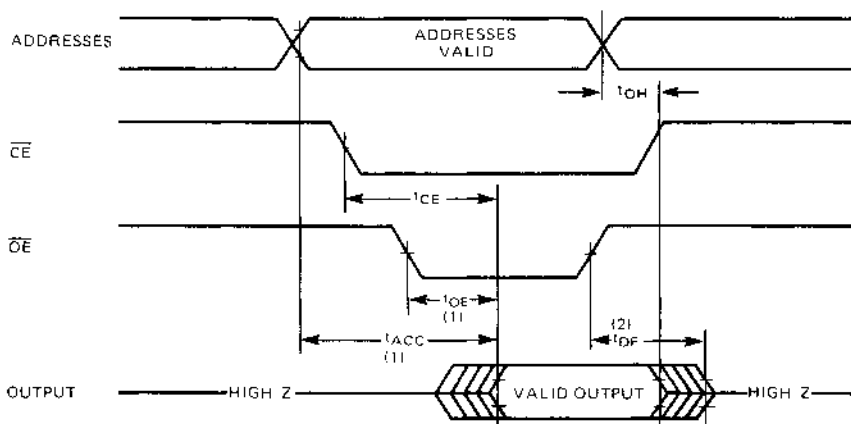

Note: (1) \overline{OE} may be delayed up to $t_{ACC} - t_{OE}$ after the falling edge of \overline{CE} without impact on t_{ACC} .

(2) t_{DF} is specified from \overline{OE} or \overline{CE} , whichever occurs first.

PROGRAMMING/ERASING INFORMATION

Memory Cell Description

The MBM2732A is fabricated using a single-transistor stacked gate cell construction, implemented via double-layer polysilicon technology. The individual cells consist of a bottom floating gate and a top select gate (see Fig. 1). The top gate is connected to the row decoder, while the floating gate is used for charge storage. The cell is programmed by the injection of high energy electrons through the oxide and onto the floating gate. The presence of the charge on the floating gate causes a shift in the cell threshold (refer to Fig. 2). In the initial state the cell has a low threshold (V_{TH1}) which will enable the transistor to be turned on when the cell is selected (via the top select gate). Programming shifts the threshold to a higher level (V_{TH0}), thus preventing the cell transistor from turning on when selected. The status of the cell (i.e., whether programmed or not) can be determined by examining its state at the sense threshold (V_{THS}), as indicated by the dotted line in Fig. 2.

Fig. 1 — MEMORY CELL

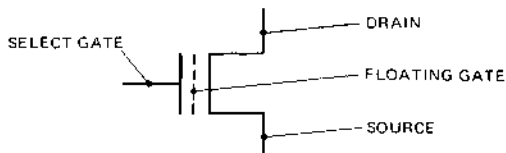
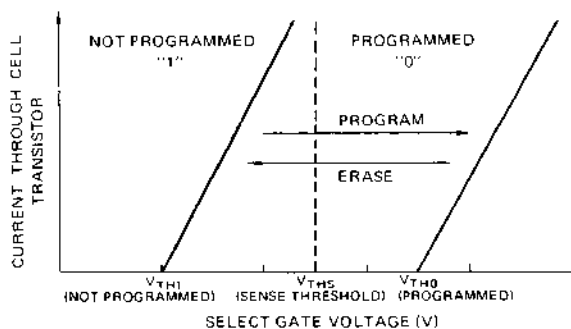

Fig. 2 — MEMORY CELL THRESHOLD SHIFT



Programming

Upon delivery from Fujitsu, or after each erasure (see Erasure section), the MBM2732A has all 32,768 bits in the "1", of high, state. "0's" are loaded into the MBM2732A through the procedure of programming.

For MBM2732A-20/-25/-30, the programming mode is entered when +21V is applied to the \overline{OE}/V_{PP} pin. For MBM2732A-35/-35X, the programming mode is entered when +25V or +21V is applied to the \overline{OE}/V_{PP} pin. A 0.1 μ F capacitor between \overline{OE}/V_{PP} and V_{SS} is needed to prevent excessive voltage transients, which could damage the device. The address to be programmed is applied to the proper address pins. 8-bit patterns are placed on the respective data output pins. The voltage levels should be standard TTL levels. When both the address and data

are stable, a 50 msec, TTL Low-level pulse is applied to the \overline{CE} input to accomplish the programming.

The procedure can be done manually, address by address, randomly, or automatically via the proper circuitry. All that is required is that one 50 msec program pulse be applied at each address to be programmed. It is necessary that this program pulse width not exceed 55 msec. Therefore, applying a DC level to the \overline{CE} input is prohibited when programming.

Erasure

In order to clear all locations of their programmed contents, it is necessary to expose the MBM2732A to an ultraviolet light source. A dosage of 15 W-second/cm² is required to completely erase an MBM2732A. This

dosage can be obtained by exposure to an ultraviolet lamp (wavelength of 2537 Angstroms (\AA)) with intensity of 12000 μ W/cm² for 15 to 20 minutes. The MBM2732A should be about one inch from the source and all filters should be removed from the UV light source prior to erasure.

It is important to note that the MBM2732A and similar devices, will erase with light sources having wavelengths shorter than 4000 \AA . Although erasure times will be much longer than with UV sources at 2537 \AA , nevertheless the exposure to fluorescent light and sunlight will eventually erase the MBM2732A, and exposure to them should be prevented to realize maximum system reliability. If used in such an environment, the package window should be covered by an opaque label or substance.

MBM2732A**PROGRAMMING / ERASING INFORMATION** (continued)**DC Characteristics**(T_A = 25 ± 3°C, V_{CC}(1) = 5V ± 5%, V_{PP} = 21V ± 0.5V, V_{SS} = 0V) (For MBM2732A-35I-35X: V_{PP} = 21V or 25V)

Parameter	Symbol	Min	Typ	Max	Unit
Input Leakage Current (V _{IN} = 5.25V/0.45V)	I _{LI}	—	—	10	μA
V _{PP} Supply Current During Programming Pulse ($\overline{CE} = V_{IL}, \overline{OE}/V_{PP} = V_{PP}$)	I _{PP}	—	—	30	mA
V _{CC} Supply Current	I _{CC2}	—	—	150	mA
Input Low Level	V _{IL}	-0.1	—	0.8	V
Input High Level	V _{IH}	2.0	—	V _{CC} + 1	V
Output Low Voltage During Verify (I _{OL} = 2.1mA)	V _{OL}	—	—	0.45	V
Output High Voltage During Verify (I _{OH} = -400μA)	V _{OH}	2.4	—	—	V

Note: (1) V_{CC} must be applied either coincidentally or before V_{PP} and removed either coincidentally or after V_{PP}.

(2) V_{PP} must not be greater than 21.5 volts (26.5 Volts for MBM2732A-35I-35X) including overshoot. Permanent device damage may occur if the device is taken out or put into socket remaining V_{PP} = (21 volts for MBM2732A-20I-25I-30, 21 volts or 25 volts for MBM2732A-35I-35X). Also, during \overline{CE} , PGM = V_{IL}, V_{PP} must not be switched from V_{IL} to V_{PP} volts or vice-versa.

AC Characteristics(T_A = 25 ± 3°C, V_{CC}(1) = 5V ± 5%, V_{PP} = 21V ± 0.5V) (21V ± 0.5V or 25V ± 0.5V for MBM2732A-35I-35X)

Parameter	Symbol	Min	Typ	Max	Unit
Address Setup Time	t _{AS}	2	—	—	μS
Output Enable Setup Time	t _{OES}	2	—	—	μS
Data Setup Time	t _{DS}	2	—	—	μS
Address Hold Time	t _{AH}	0	—	—	μS
Output Enable Hold Time	t _{OEH}	2	—	—	μS
Data Hold Time	t _{DH}	2	—	—	μS
Chip Enable to Output Float Delay ($\overline{OE} = V_{IL}$)	t _{DF}	0	—	130	ns
Chip Enable to Data Valid Time ($\overline{CE} = V_{IL}, \overline{OE}/V_{PP} = V_{IL}$)	t _{DV}	—	—	1	μS
Program Pulse Width	t _{PW}	45	50	55	ms
Program Pulse Rise Time	t _{PRT}	50	—	—	ns
V _{PP} Recovery Time	t _{VR}	2	—	—	μS

PROGRAMMING WAVEFORMS

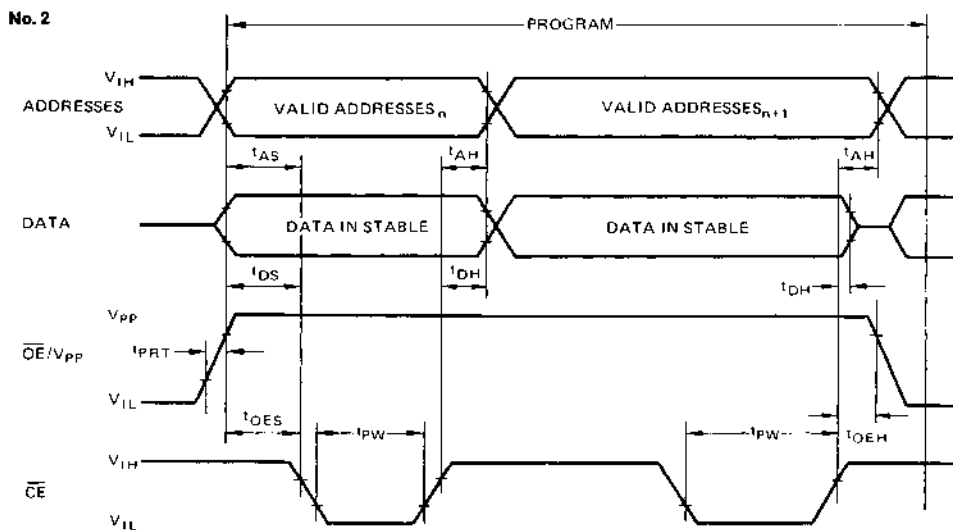
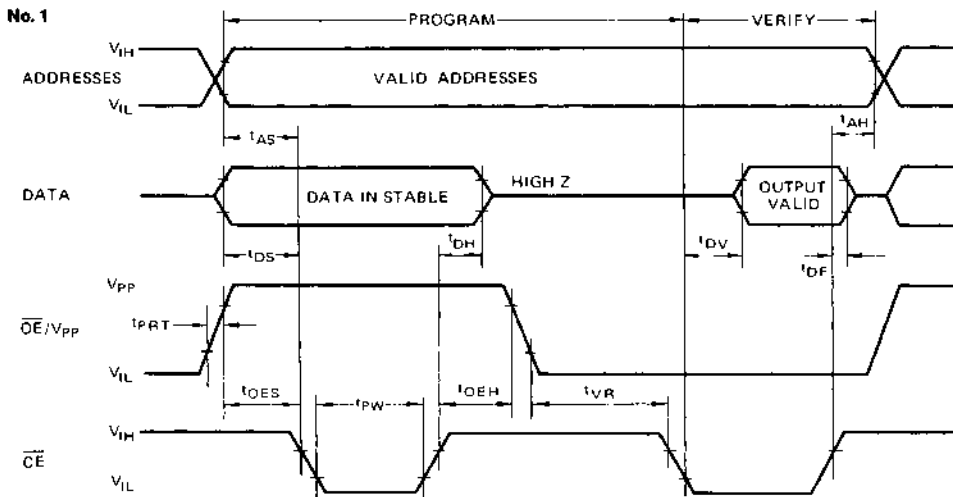

Note: In PROGRAMMING WAVEFORMS No. 2, Address Hold Time t_{AH} must be more than 2 μ s.