

Product Specification

Part Name: 7.0 inch TFT Display Module

Element Touch Part ID: ETT070B1KRGB

Data: 2024/01/10

Preliminary Specification

Final Specification

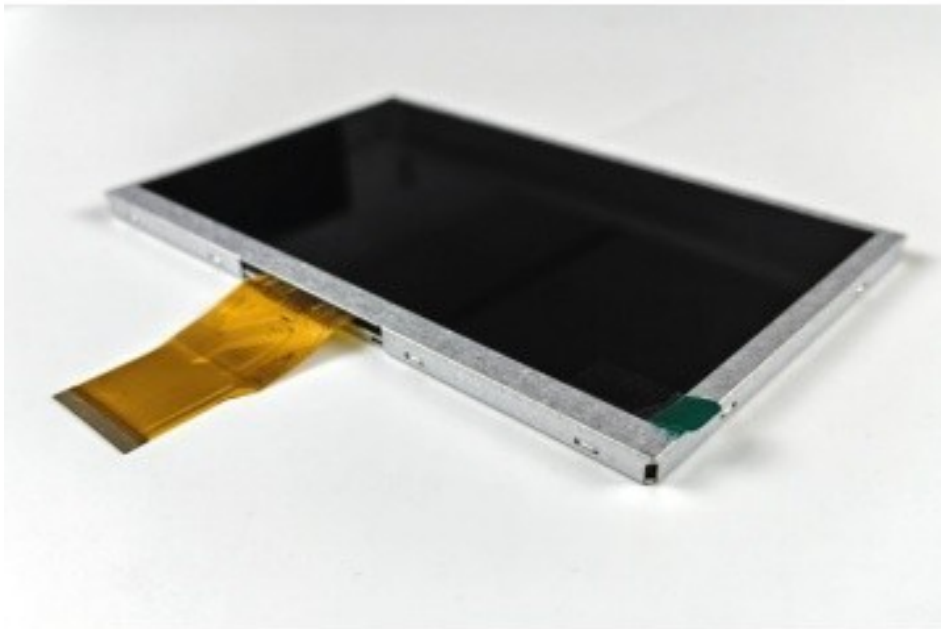

Record of Revision

Version	Revise Date	Page	Content
Pre-Spec0.1	2024/01/10	All	7SD IPS

Contents

1. General Specifications.....	4
2. Pin Assignment.....	5
3. Operation Specifications.....	8
3.1. Absolute Maximum Ratings.....	8
3.1.1. Typical Operation Conditions.....	9
3.1.2. Current Consumption	10
3.2. Power Sequence	10
3.3. Timing Characteristics	11
3.3.1. AC Electrical Characteristics	11
3.3.2. Input Clock and Data Timing Diagram	12
3.3.3. Timing.....	12
3.3.4. Data Input Format.....	13
4. Optical Specifications.....	14
5. Reliability Test Items.....	17
6. General Precautions.....	18
6.1. Safety	18
6.2. Handling	18
6.3. Static Electricity	18
6.4. Storage	18
6.5. Cleaning	18
7. Mechanical Drawing	19
8. Package Drawing	20

1. General Specifications

No.	Item	Specification	Remark
1	LCD size	7.0 inch(Diagonal)	
2	Driver element	a-Si IPS	
3	Resolution	1024 × 3(RGB) × 600	
4	Display mode	Normally Black, FFS	
5	Dot pitch	0.1506(W)×0.1432(H) mm	
6	Active area	154.2144(W) × 85.92(H) mm	
7	Panel size	164.9(W)× 100(H) × 5.7(D) mm	Note 1
8	Surface treatment	Anti-Glare Hardness:3H	
9	Color arrangement	RGB vertical stripe	
10	Display Color	16.7M	
11	Interface	RGB Interface	

Note 1: Refer to Mechanical Drawing.

2. Pin Assignment

FPC Connector is used for the module electronics interface. The recommended model is FH12A-50S-0.5SH manufactured by Hirose.

Pin No.	Symbol	I/O	Function	Remark
1	V _{LED+}	P	Power for LED backlight (Anode)	
2	V _{LED+}	P	Power for LED backlight (Anode)	
3	V _{LED-}	P	Power for LED backlight (Cathode)	
4	V _{LED-}	P	Power for LED backlight (Cathode)	
5	GND	P	Power ground	
6	V _{COM}	I	Common voltage	
7	DV _{DD}	P	Power for Digital Circuit	
8	MODE	I	DE/SYNC mode select	Note 1
9	DE	I	Data Input Enable	
10	VS	I	Vertical Sync Input	
11	HS	I	Horizontal Sync Input	
12	B7	I	Blue data(MSB)	
13	B6	I	Blue data	
14	B5	I	Blue data	
15	B4	I	Blue data	
16	B3	I	Blue data	
17	B2	I	Blue data	
18	B1	I	Blue data	Note 2
19	B0	I	Blue data(LSB)	Note 2
20	G7	I	Green data(MSB)	
21	G6	I	Green data	
22	G5	I	Green data	
23	G4	I	Green data	
24	G3	I	Green data	
25	G2	I	Green data	
26	G1	I	Green data	Note 2

27	G0	I	Green data(LSB)	Note 2
28	R7	I	Red data(MSB)	
29	R6	I	Red data	
30	R5	I	Red data	
31	R4	I	Red data	
32	R3	I	Red data	
33	R2	I	Red data	
34	R1	I	Red data	Note 2
35	R0	I	Red data(LSB)	Note 2
36	GND	P	Power Ground	
37	DCLK	I	Sample clock	Note 3
38	GND	P	Power Ground	
39	L/R	I	Left / right selection	Note 4,5
40	U/D	I	Up/down selection	Note 4,5
41	V _{GH}	P	Gate ON Voltage	
42	V _{GL}	P	Gate OFF Voltage	
43	AV _{DD}	P	Power for Analog Circuit	
44	RESET	I	Global reset pin.	Note 6
45	NC	-	No connection	
46	V _{COM}	I	Common Voltage	
47	DITHB	I	Dithering setting DITH="L" 6bit resolution(last 2 bit of input data truncated) DITH="H" 8bit resolution(default setting)	
48	GND	P	Power Ground	
49	NC	-	No connection	
50	NC	-	No connection	

I: input, O: output, P: Power

Note 1: DE/SYNC mode select. Normally pull high.

When select DE mode, MODE="1", VS and HS must pull high.

When select SYNC mode, MODE="0", DE must be grounded.

Note 2: When input 18 bits RGB data, the two low bits of R,G and B data must be grounded.

Note 3: Data shall be latched at the falling edge of DCLK.

Note 4: Selection of scanning mode

Setting of scan control input		Scanning direction
U/D	L/R	
GND	DV _{DD}	Up to down, left to right
DV _{DD}	GND	Down to up, right to left
GND	GND	Up to down, right to left
DV _{DD}	DV _{DD}	Down to up, left to right

Note 5: Definition of scanning direction.
Refer to the figure as below:

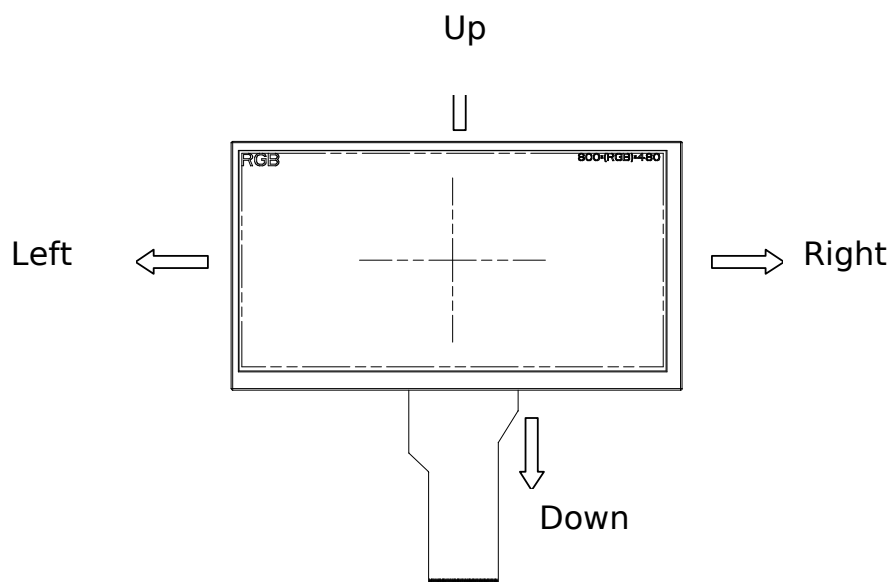

Note 6: Global reset pin. Active low to enter reset state. Suggest to connect with an RC reset circuit for stability. Normally pull high.

3. Operation Specifications

3.1. Absolute Maximum Ratings

(Note 1)

Item	Symbol	Values		Unit	Remark
		Min.	Max.		
Power voltage	DV_{DD}	-0.3	5.0	V	
	AV_{DD}	-0.5	14.85	V	
	V_{GH}	-0.3	40	V	
	V_{GL}	-20.0	0.3	V	
Operation Temperature	T_{OP}	-20	70	°C	
Storage Temperature	T_{ST}	-30	80	°C	

Note 1: The absolute maximum rating values of this product are not allowed to be exceeded at any times. Should a module be used with any of the absolute maximum ratings exceeded, the characteristics of the module may not be recovered, or in an extreme case, the module may be permanently destroyed.

3.1.1. Typical Operation Conditions

(Note 1)

Item	Symbol	Values			Unit	Remark
		Min.	Typ.	Max.		
Power voltage	DV_{DD}	3.0	3.3	3.6	V	Note 3
	AV_{DD}	9.4	9.6	9.8	V	
	V_{GH}	17	18	19	V	
	V_{GL}	-6.6	-6	-5.4	V	
Input signal voltage	V_{COM}	2.8	3.2	3.6	V	Note 2
Input logic high voltage	V_{IH}	$0.7 \times V_{DD}$	-	V_{DD}	V	Note 3
Input logic low voltage	V_{IL}	GND	-	$0.3 \times V_{DD}$	V	

Note 1: Be sure to apply DV_{DD} and V_{GL} to the LCD first, and then apply V_{GH} .

Note 2: Typical V_{COM} is only a reference value. It must be optimized according to each LCM. Please use VR and base on below application circuit.

Note 3: DV_{DD} setting should match the signals output voltage (refer to Note 3) of customer's system board.

3.1.2. Current Consumption

ITEM	SYMBOL	CONDITION	MIN	TYPE	MAX	UNIT	NOTE
Gate On Power Current	IVGH	VGH =18V	--	0.5	1	mA	Note1
Gate Off Power Current	IVGL	VGL= -6V	--	0.5	1	mA	Note1
Digital Power Current	IDVDD	DVDD = 3.3V	--	30	45	mA	Note1
Analog Power Current	IAVDD	AVDD = 9.6V	--	35	45	mA	Note1
Total Power Consumption	PC		--	447	604	mW	Note1

Note1: Typ. specification : Gray-level test Pattern

Max. specification : White test Pattern



256 gray pattern



White Pattern

3.1.3. Backlight Driving Conditions

Item	Symbol	Values			Unit	Remark
		Min.	Typ.	Max.		
Voltage for LED backlight	V_L	16.2	18	19.8	V	Note 1
Current for LED backlight	I_L		180	200	mA	
LED life time	-	30,000	-	-	Hr	Note 2

Note 1: The LED Supply Voltage is defined by the number of LED at $T_a=25\text{ }^\circ\text{C}$ and $I_L = 180\text{mA}$.

Note 2: The "LED life time" is defined as the module brightness decrease to 50% original brightness at $T_a=25\text{ }^\circ\text{C}$ and $I_L = 180\text{mA}$. The LED lifetime could be decreased if operating I_L is larger than 180mA.

3.2. Power Sequence

In order to prevent IC from power on reset fail, the rising time (TPOR) of the digital power supply VDD should be maintained within the given specifications. Refer to "AC Characteristics" for more detail on timing.

a. Power on/off timing sequence

Power On: DVDD→AVDD/VGL →VGH → Video & Logic Signal→ Backlight

Power Off: Backlight→ Video & Logic Signal→ VGH→ AVDD/VGL→ DVDD

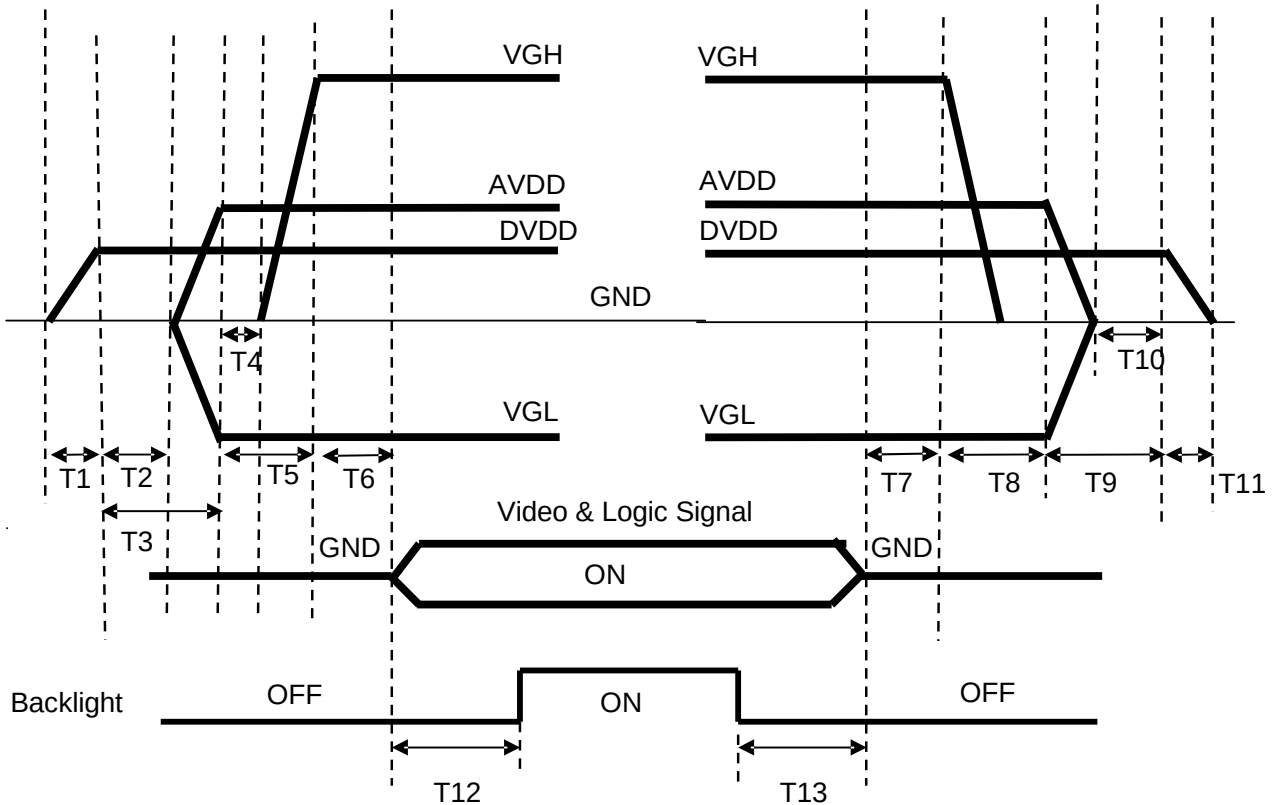

$$0 < T1 \leq 10\text{ms}$$

$$T2 > 0\text{ms}$$

$$T3 > 20\text{ms}$$

$$T4 > 0\text{ms}$$

$$T5 > 10\text{ms}$$

$$0 < T6 \leq 10\text{ms}$$

$$T12 \geq 200\text{ms}$$

$$T7 > 0\text{ms}$$

$$T8 > 0\text{ms}$$

$$T9 > 0\text{ms}$$

$$T10 > 0\text{ms}$$

$$0 < T11 \leq 10\text{ms}$$

$$T13 \geq 200\text{ms}$$

3.3. Timing Characteristics

3.3.1. AC Electrical Characteristics

Parameter	Symbol	Spec.			Unit	Condition
		Min.	Typ.	Max.		
DVDD Power On Slew Rate	TPOR	-	-	20	ms	From 0V to 90% DVDD
RSTB Pulse Width	TRst	50	-	-	us	DCLK=65MHz
DCLK Cycle Time	Tcph	14	-	-	ns	
DCLK Pulse Duty	Tcwh	40	50	60	%	
VSD Setup Time	Tvst	5	-	-	ns	
VSD Hold Time	Tvhd	5	-	-	ns	
HSD Setup Time	Thst	5	-	-	ns	
HSD Hold Time	Thhd	5	-	-	ns	
Data Setup Time	Tdsu	5	-	-	ns	D0[7:0],D1[7:0],D2[7:0] to DCLK
Data Hold Time	Tdhd	5	-	-	ns	D0[7:0],D1[7:0],D2[7:0] to DCLK
DEN Setup Time	Tesu	5	-	-	ns	
DEN Hold Time	Tehd	5	-	-	ns	

3.3.2. Input clock and data timing diagram

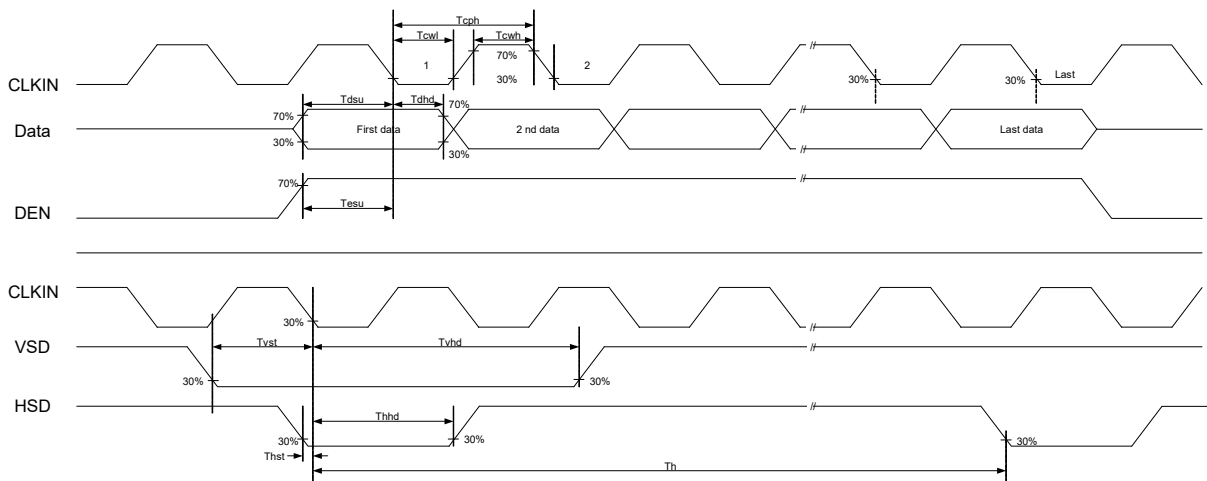

3.3.3. Timing

DE mode

Parameter	Symbol	Spec.			Unit
		Min.	Typ.	Max.	
DCLK frequency	fclk	40.8	51.2	67.2	MHz
Horizontal display area	thd	1024			DCLK
HSD period	th	1114	1344	1400	DCLK
HSD blanking	thb+thfp	90	320	376	DCLK
Vertical display area	tvd	600			T _H
VSD period	tv	610	635	800	T _H
VSD blanking	tvbp+tvfp	10	35	200	T _H

DE mode (1024x600)

HV mode

• Horizontal timing

Parameter	Symbol	Spec.			Unit
		Min.	Typ.	Max.	
DCLK frequency	fclk	44.9	51.2	63	MHz
Horizontal display area	thd	1024			DCLK
HSD period	th	1200	1344	1400	DCLK
HSD pulse Width	thpw	1	-	140	DCLK
HSD back porch	thbp	160			DCLK
HSD front porch	thfp	16	160	216	DCLK

HV mode horizontal timing (1024x600)

• Vertical timing

Parameter	Symbol	Spec.			Unit
		Min.	Typ.	Max.	
Vertical display area	tv _d	600			T _H
VSD period	tv	624	635	750	T _H
VSD pulse width	tv _{pw}	1	-	20	T _H
VSD back porch	tv _{bp}	23			T _H
VSD front porch	tv _{fp}	1	12	127	T _H

HV mode vertical timing (1024x600)

3.3.4. Data Input Format

• Vertical timing

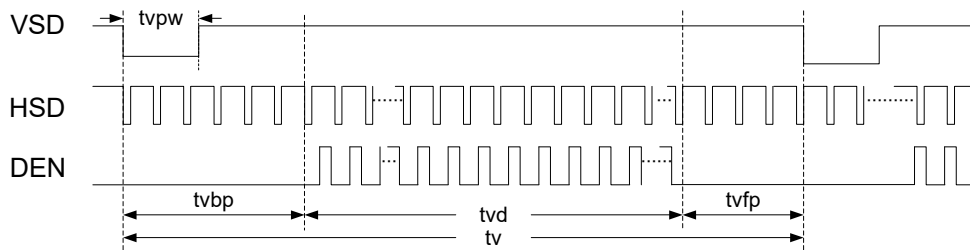

Vertical input timing diagram

• Horizontal timing

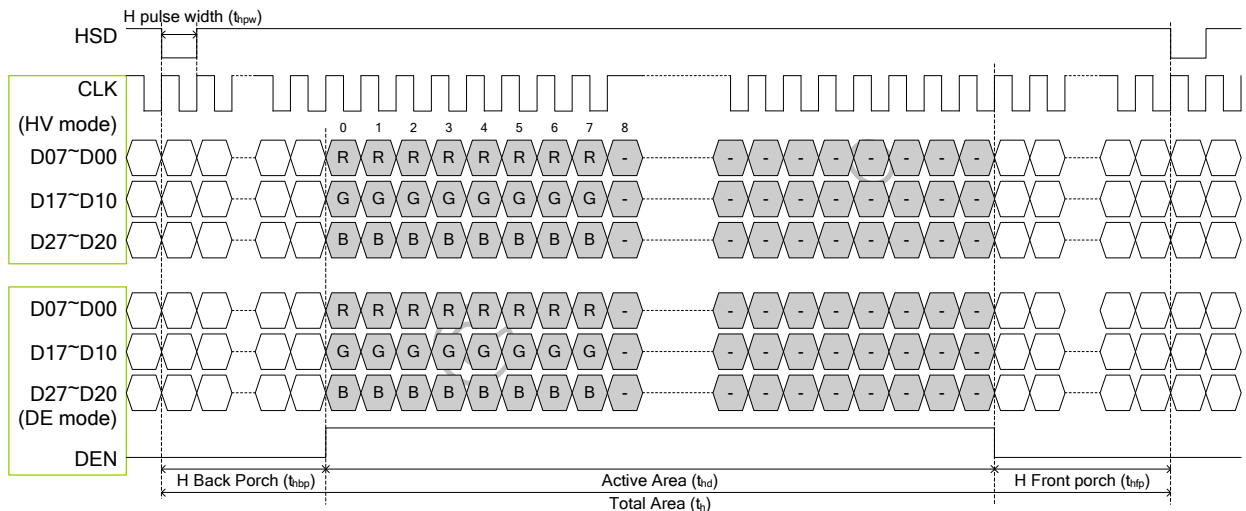

Horizontal input timing diagram

4. Optical Specifications

Items	Symbol	Condition	Min.	Typ.	Max.	Unit	Remark	
Viewing angles	θ_T	Center CR \geq 10	80	85	-	Degree.	Note2	
	θ_B		80	85	-			
	θ_L		80	85	-			
	θ_R		80	85	-			
Contrast Ratio	CR	$\Theta = 0$		800	-	-	Note1, Note3	
Response Time	$T_{ON+T_{off}}$	25°C	-	30	50	ms	Note1, Note4	
Chromaticity	Red	R_X	$\Theta = 0$ Normal viewing angle	0.540	0.590	0.650	-	
		R_Y		0.260	0.310	0.360	-	
	Green	G_X		0.265	0.315	0.365		
		G_Y		0.495	0.545	0.595		
	Blue	B_X		0.075	0.125	0.175		
		B_Y		0.026	0.076	0.126		
	White	W_X		0.240	0.290	0.340		
		W_Y		0.266	0.316	0.366		
Uniformity	U		70	75	-	%	Note1,	
Luminance	L		900	1000			Note1, Note7	

Test Conditions:

1. $DV_{DD}=3.3V$ the ambient temperature is 25°C
2. The test systems refer to Note 1 and Note 2.

Note 1: Definition of optical measurement system.

The optical characteristics should be measured in dark room. After 5 minutes operation, the optical properties are measured at the center point of the LCD screen. All input terminals LCD panel must be ground when measuring the center area of the panel.

Note 1: Definition of viewing angle range

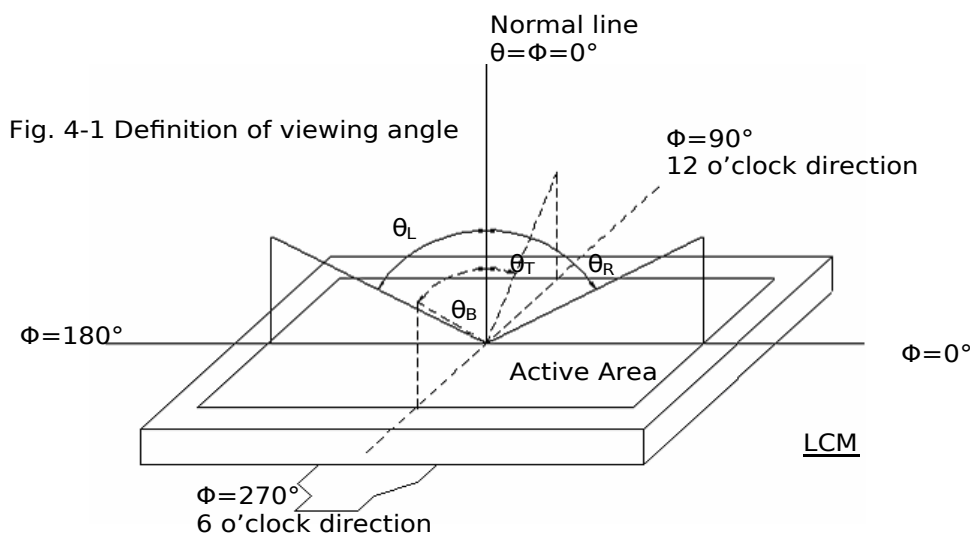

Note 2: Definition of optical measurement system.

The optical characteristics should be measured in dark room. After 30 minutes operation, the optical properties are measured at the center point of the LCD screen. (Response time is measured by Photo detector TOPCON BM-7, other items are measured by BM-5A/Field of view: 1° /Height: 500mm.)

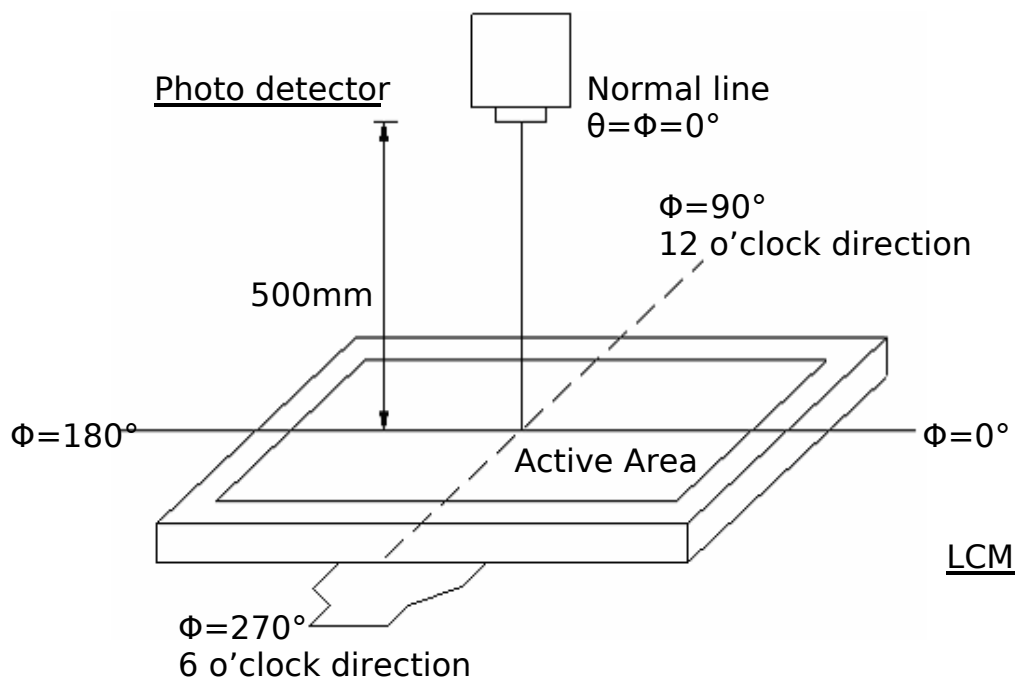

Fig. 4-2 Optical measurement system setup

Note 3: Definition of Response time

The response time is defined as the LCD optical switching time interval between "White" state and "Black" state. Rise time (T_{ON}) is the time between photo detector output intensity changed from 90% to 10%. And fall time (T_{OFF}) is the time between photo detector output intensity changed from 10% to 90%.

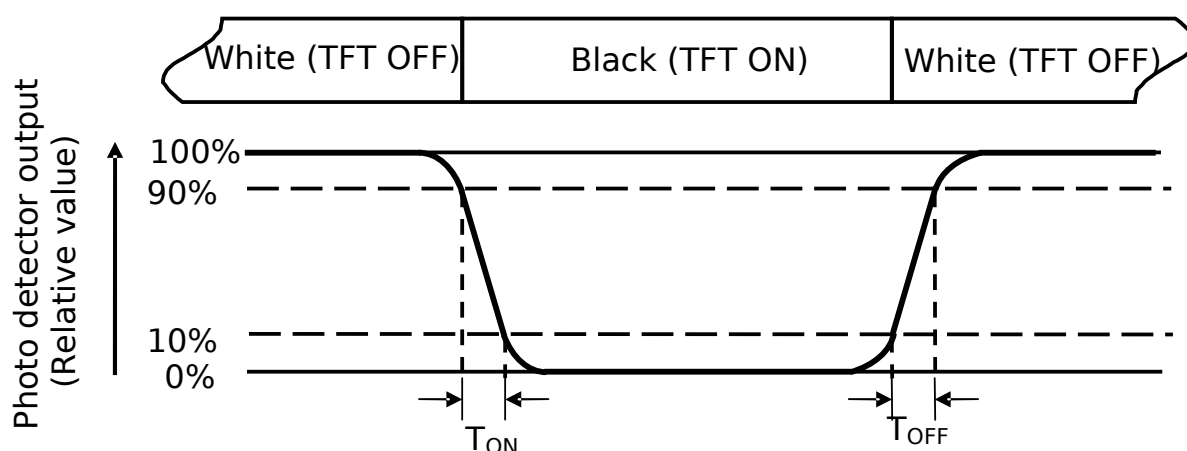

Fig. 4-3 Definition of response time

Note 4: Definition of contrast ratio

$$\text{Contrast ratio (CR)} = \frac{\text{Luminance measured when LCD on the "White" state}}{\text{Luminance measured when LCD on the "Black" state}}$$

Note 5: Definition of color chromaticity (CIE1931)

Color coordinates measured at center point of LCD.

Note 6: All input terminals LCD panel must be ground while measuring the center area of the panel.

Note 7: Definition of Luminance Uniformity

Active area is divided into 9 measuring areas (Refer to Fig. 4-4).Every measuring point is placed at the center of each measuring area.

$$\text{Luminance Uniformity (Yu)} = \frac{B_{\min}}{B_{\max}}$$

L-----Active area length W----- Active area width

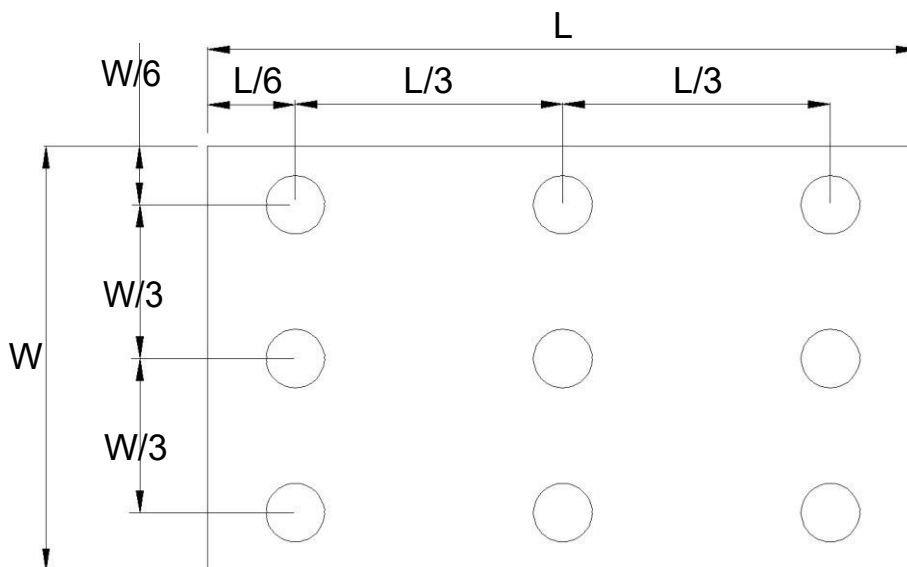

Fig. 4-4 Definition of measuring points

B_{\max} : The measured maximum luminance of all measurement position.

B_{\min} : The measured minimum luminance of all measurement position.

5. Reliability Test Items

(Note3)

Item	Test Conditions	Remark
High Temperature Storage	Ta = 80°C 240hrs	Note 1, Note 4
Low Temperature Storage	Ta = -30°C 240hrs	Note 1, Note 4
High Temperature Operation	Ts = 70°C 240hrs	Note 2, Note 4
Low Temperature Operation	Ta = -20°C 240hrs	Note 1, Note 4
Operate at High Temperature and Humidity	+60°C, 90%RH 240hrs	Note 4
Thermal Shock	-20°C/30 min ~ +70°C/30 min for a total 100 cycles, Start with cold temperature and end with high temperature.	Note 4
Vibration Test	Frequency range:10~55Hz Stroke:1.5mm Sweep:10Hz~55Hz~10Hz 2 hours for each direction of X. Y. Z. (6 hours for total)	
Mechanical Shock	100G 6ms,±X, ±Y, ±Z 3 times for each direction	
Package Vibration Test	Random Vibration : 0.015G*G/Hz from 5-200HZ, -6dB/Octave from 200-500HZ 2 hours for each direction of X. Y. Z. (6 hours for total)	
Package Drop Test	Height:60 cm 1 corner, 3 edges, 6 surfaces	
Electro Static Discharge	± 2KV, Human Body Mode, 100pF/1500Ω	Non-operating

Note 1: Ta is the ambient temperature of samples.

Note 2: Ts is the temperature of panel's surface.

Note 3: In the standard condition, there shall be no practical problem that may affect the display function. After the reliability test, the product only guarantees operation, but don't guarantee all of the cosmetic specification.

Note 4: Before cosmetic and function test, the product must have enough recovery time, at least 2 hours at room temperature.

6. General Precautions

6.1. Safety

Liquid crystal is poisonous. Do not put it in your mouth. If liquid crystal touches your skin or clothes, wash it off immediately by using soap and water.

6.2. Handling

1. The LCD panel is plate glass. Do not subject the panel to mechanical shock or to excessive force on its surface.
2. The polarizer attached to the display is easily damaged. Please handle it carefully to avoid scratch or other damages.
3. To avoid contamination on the display surface, do not touch the module surface with bare hands.
4. Keep a space so that the LCD panels do not touch other components.
5. Put cover board such as acrylic board on the surface of LCD panel to protect panel from damages.
6. Transparent electrodes may be disconnected if you use the LCD panel under environmental conditions where the condensation of dew occurs.
7. Do not leave module in direct sunlight to avoid malfunction of the ICs.

6.3. Static Electricity

1. Be sure to ground module before turning on power or operating module.
2. Do not apply voltage which exceeds the absolute maximum rating value.

6.4. Storage

1. Store the module in a dark room where must keep at $25\pm 10^{\circ}\text{C}$ and 65%RH or less.
2. Do not store the module in surroundings containing organic solvent or corrosive gas.
3. Store the module in an anti-electrostatic container or bag.

6.5. Cleaning

1. Do not wipe the polarizer with dry cloth. It might cause scratch.
2. Only use a soft sloth with IPA to wipe the polarizer, other chemicals might permanent damage to the polarizer.

7. Mechanical Drawing

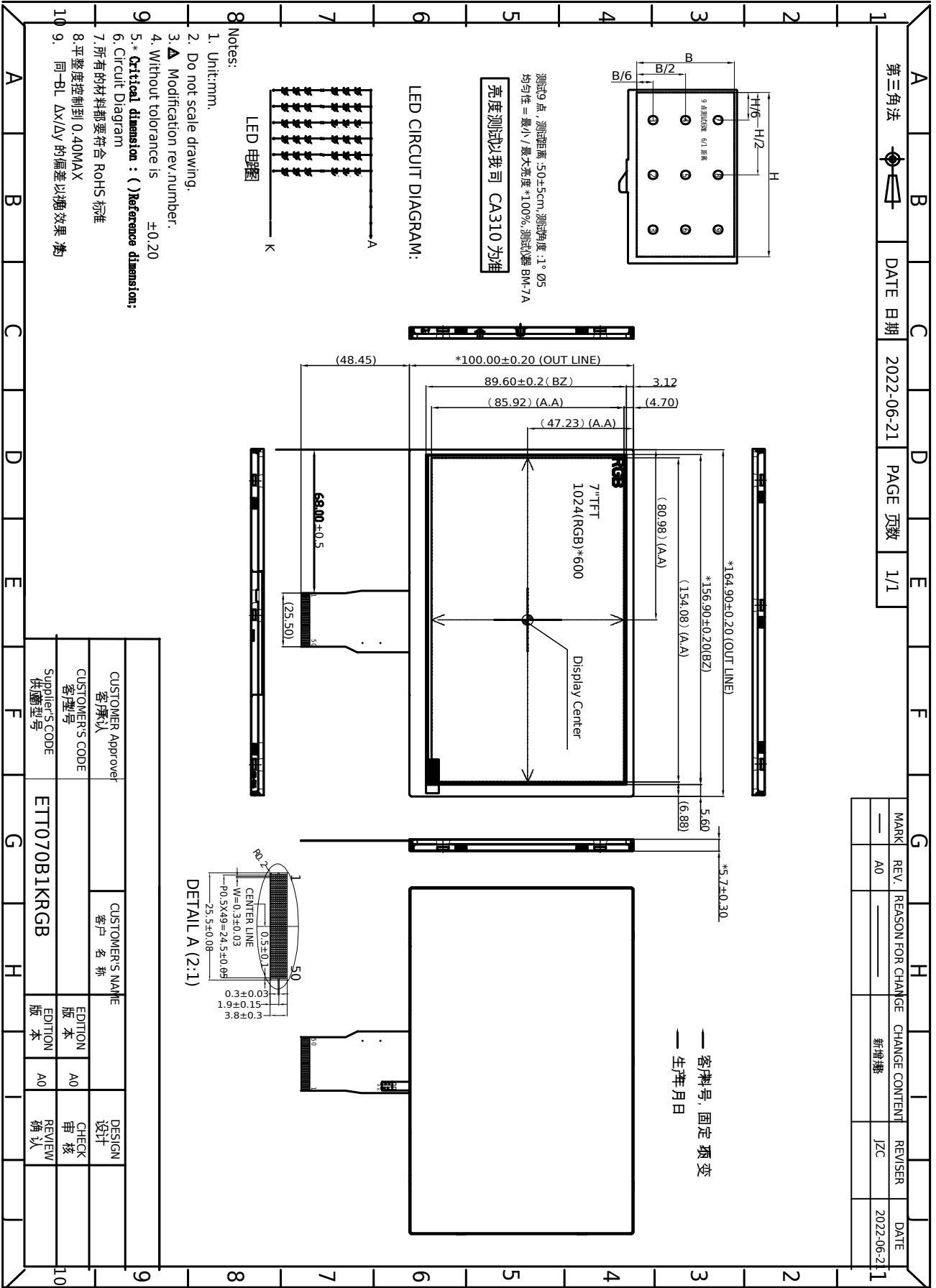

8. Package Drawing

A	B	C	D	E	F	G	H	I	J		
第三角法		DATE 日期	2018-6-8	PAGE 页数	1/1	MARK	REV. A0	REASON FOR CHANGE	CHANGE CONTENT	REVISER	DATE
									新增糊	YSJ	2018-06-08

Drawing Of Marks 100.00±0.5

客户名称	XXXXXXXXXX
客户订单号	XXXXXXXXXX
规格型号	ETT070*+-**
物料类别	
单箱数量	60 PCS
生产日期	20**-*-***
备注	

60.00±0.5

将成品装在一个开口塑料袋中，将袋口卷折。

图说说明:

1. 客户订单号: 以业务提供为准;
2. 规格型号: 7寸推包装(固定)项
3. 物料类别: 业务提供
4. 单箱数量: 按实际实包装数量;
5. 生产日期: 以当日生产日期 为准

将1片漏放入纸板格子中，共计60pcs

使用封口胶封口并贴唛头

CUSTOMER Approver 客户承认	CUSTOMER'S NAME 客户名称	
CUSTOMER'S CODE 客户型号	EDITION 版本	CHECK 审核
Supplier'S CODE 成品型号	EDITION 版本	REVIEW 确认

7寸 165*100*5.7 标准包装