



CCS811



Ultra-Low Power Digital Gas Sensor for Monitoring Indoor Air Quality

CCS811 Datasheet

Revision: 3

Release Date: July 2021

Document Status: Production



CCS811 has been transferred from ams AG to SciSense

**The datasheet is valid in its presented form
but might still have reference to ams AG**

SciSense is a Joint Venture of ams AG

Headquarters: Sciosense B.V.
High Tech Campus 10
5656 AE Eindhoven
The Netherlands

Contact: www.sciosense.com
info@sciosense.com

Sensing tomorrow's world

CCS811

Ultra-Low Power Digital Gas Sensor for Monitoring Indoor Air Quality

General Description

The CCS811 is an ultra-low power digital gas sensor solution which integrates a metal oxide (MOX) gas sensor to detect a wide range of Volatile Organic Compounds (VOCs) for indoor air quality monitoring with a microcontroller unit (MCU), which includes an Analog-to-Digital converter (ADC), and an I²C interface.

CCS811 is based on Sciosense unique micro-hotplate technology which enables a highly reliable solution for gas sensors, very fast cycle times and a significant reduction in average power consumption.

The integrated MCU manages the sensor driver modes and measurements. The I²C digital interface significantly simplifies the hardware and software design, enabling a faster time to market.

CCS811 supports intelligent algorithms to process raw sensor measurements to output equivalent total VOC (eTVOC) and equivalent CO₂ (eCO₂) values, where the main cause of VOCs is from humans.

CCS811 supports multiple measurement modes that have been optimized for low-power consumption during an active sensor measurement and idle mode extending battery life in portable applications.

CCS811 is available in a 10 lead 2.7mm x 4.0mm x 1.1mm, 0.6mm pitch LGA package.

Ordering Information and Content Guide appear at end of datasheet.

Key Benefits & Features

The benefits and features of CCS811, Ultra-Low Power Digital Gas Sensor for Monitoring Indoor Air Quality are listed below:

Figure 1:
Added Value of Using CCS811 Sensor

Benefits	Features
<ul style="list-style-type: none"> Manages the sensor drive modes and measurements while detecting VOCs 	<ul style="list-style-type: none"> Integrated MCU
<ul style="list-style-type: none"> Provides eCO₂ level or eTVOC indication with no host intervention 	<ul style="list-style-type: none"> On-board processing
<ul style="list-style-type: none"> Simplifies the hardware and software integration 	<ul style="list-style-type: none"> Standard (100kbit/s) and fast (400kbit/s) I²C interface
<ul style="list-style-type: none"> Extend battery life in portable applications 	<ul style="list-style-type: none"> Optimised low-power modes
<ul style="list-style-type: none"> Suitable for small form-factor designs 	<ul style="list-style-type: none"> 2.7mm x 4.0mm x 1.1mm LGA package
<ul style="list-style-type: none"> Saves up to 60% in PCB footprint 	<ul style="list-style-type: none"> Low component count
<ul style="list-style-type: none"> Designed for high volume and reliability (>5years lifetime) 	<ul style="list-style-type: none"> Proven technology platform

Applications

This device can be mainly used for indoor air quality monitoring in:

- Smart phones
- Air cleaners and purifiers
- Smart thermostats
- Home controllers
- Smart accessories and IoT devices

Block Diagram

The functional blocks of this device are shown below:

Figure 2:
CCS811 Block Diagram

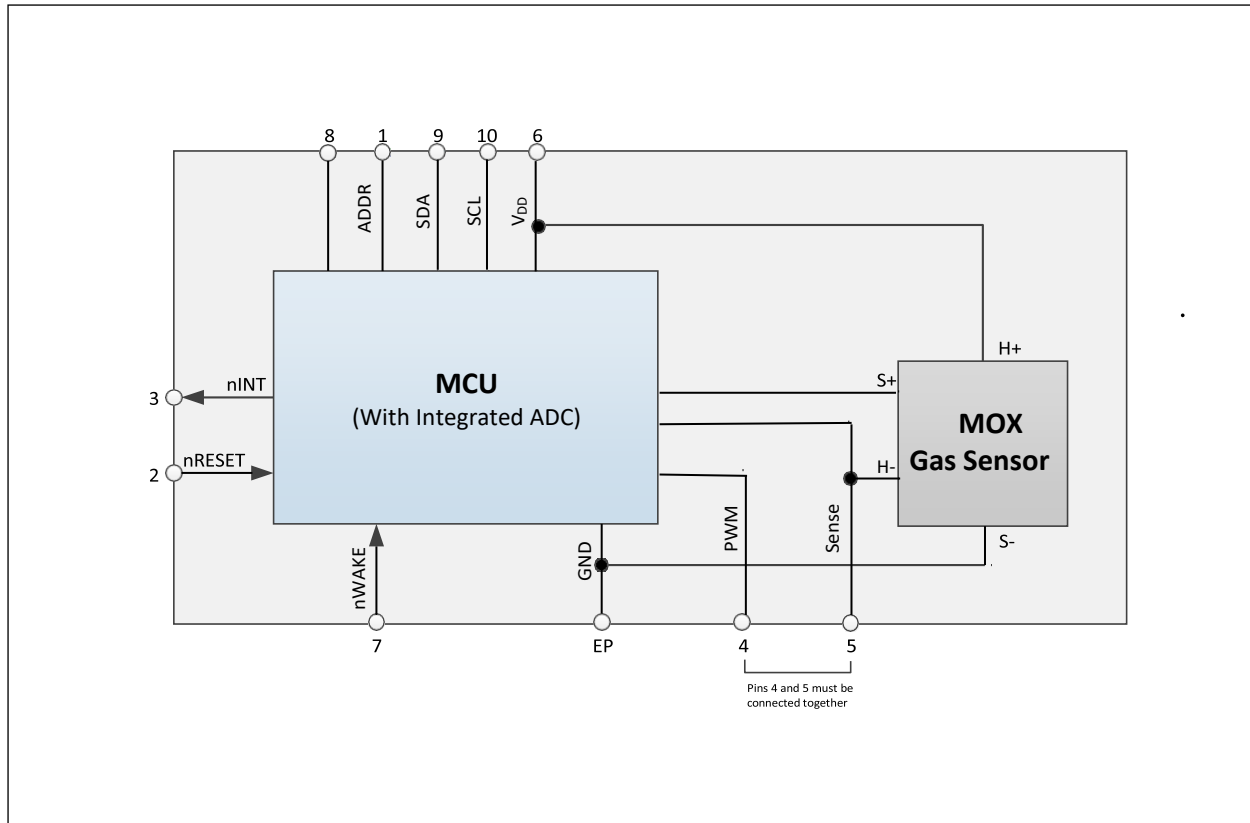

Pin Assignment

Figure 3:
Pin Diagram

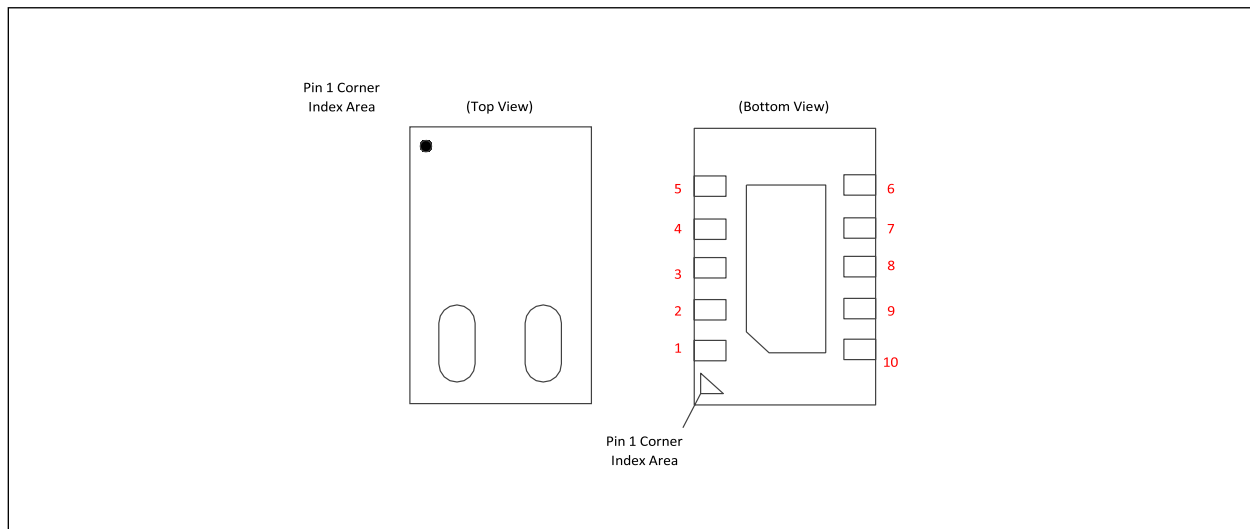

Pin Diagram: The Exposed Pad is underneath

Figure 4:
CCS811 LGA Pin Assignment

Pin No.	Pin Name	Description
1	ADDR	Single address select bit to allow alternate address to be selected <ul style="list-style-type: none"> When ADDR is low the 7 bit I²C address is decimal 90 / hex 0x5A When ADDR is high the 7 bit I²C address is decimal 91 / hex 0x5B.
2	nRESET	nRESET is an active low input and is pulled up to V _{DD} by default. nRESET is optional but 4.7kΩ pull-up and/or decoupling of the nRESET pin may be necessary to avoid erroneous noise-induced resets. This pin will be pulled low internally during reset.
3	nINT	nINT is an active low optional output. It is pulled low by the CCS811 to indicate end of measurement or a set threshold value has been triggered.
4	PWM	Heater driver PWM output. Pins 4 and 5 must be connected together.
5	Sense	Heater current sense. Pins 4 and 5 must be connected together.
6	V _{DD}	Supply voltage.
7	nWAKE	nWAKE is an active low input and should be asserted by the host prior to an I ² C transaction and held low throughout.
8	NC	No connect
9	SDA	SDA pin is used for I ² C data. Should be pulled up to V _{DD} with a resistor.
10	SCL	SCL pin is used for I ² C clock. Should be pulled up to V _{DD} with a resistor.
EP	Exposed Pad	Connect to ground.

Absolute Maximum Ratings

Stresses beyond those listed under [Absolute Maximum Ratings](#) may cause permanent damage to the device. These are stress ratings only. Functional operation of the device at these or any other conditions beyond those indicated under [Electrical Characteristics](#) is not implied. Exposure to absolute maximum rating conditions for extended periods may affect device reliability

Figure 5:
Absolute Maximum Ratings

Symbol	Parameter	Min	Max	Units	Comments
Electrical Parameters					
$V_{DD}^{(1)}$	Supply Voltage	1.8 ⁽²⁾	3.6	V	
I_{DD}	Average Supply Current		30	mA	In mode 1
I_{DDPeak}	Peak Supply Current		54	mA	In modes 2 and 3
P	Power Consumption		60	mW	In mode 1
Electrostatic Discharge					
ESD_{HBM}	Human Body Model	±2000		V	
ESD_{CDM}	Charged Device Model	±1000		V	
Environmental Conditions					
$T_{AMB}^{(3)}$	Ambient Temperature for Operation	-40	85	°C	
T_{STRG}	Storage Temperature	-40	125	°C	
RH_{NC}	Relative Humidity (non-condensing)	10	95	%	
MSL	Moisture Sensitivity Level	1			Unlimited max. floor life time

Note(s):

1. The supply voltage V_{DD} is sampled during boot and should not vary during operation.
2. The minimum supply voltage V_{DD} is 1.8V and should not drop below this value for reliable device operation.
3. Sensors are electrically operable in this range, however indoor air quality performance will vary in this range.

Electrical Characteristics

Figure 6:
Electrical Characteristics

Parameters	Conditions	Min	Typ ⁽⁶⁾	Max	Units
Supply Voltage (V_{DD}) ^{(1), (2)}		1.8		3.3	V
Supply Current (I_{DD}) ⁽³⁾	During measuring at 1.8V		26		mA
	Average over pulse cycle ⁽³⁾ at 1.8V		0.7		mA
	Sleep Mode at 1.8V		19		μ A
Power Consumption	Idle Mode 0 at V_{DD} = 1.8V		0.034		mW
	Mode 1 & 4 at V_{DD} = 1.8V		46		mW
	Mode 2 at V_{DD} = 1.8V		7		mW
	Mode 3 at V_{DD} = 1.8V		1.2		mW
Logic High Input (nRESET, nWAKE, ADDR, SCL and SDA) ⁽⁵⁾		$V_{DD} - 0.5$		V_{DD}	V
Logic Low Input (nRESET, nWAKE, ADDR, SCL and SDA) ⁽⁵⁾		0		0.6	V
Logic High Output (nINT)		$V_{DD} - 0.7$		V_{DD}	V
Logic Low Output (nINT, SCL and SDA)		0		0.6	V
Product Lifetime (L_T) ⁽⁶⁾	In Mode 1		>5		Years

Note(s):

1. The supply voltage V_{DD} is sampled during boot and should not vary during operation.
2. The maximum V_{DD} ramp time for Power On is 3ms.
3. Typical values for 1.8V supply voltage (V_{DD}).
4. Average Supply Current (I_{DD}) for a sensor measurement once every 60 seconds.
5. For SDA and SCL timing refer NXP I²C – bus specification and user manual UM10204.
6. Typical values at 25°C and 50% RH.

Figure 7:
Timing Characteristics

Parameters	Conditions	Min	Typ	Max	Units
t_{APP_START}	Time between giving the APP_START command in boot mode and the device being ready for new I ² C commands			1	ms
$t_{WAKE}^{(1)}$	Time after falling nWAKE and the device being ready for new I ² C commands			50	μ s
$t_{START}^{(2)}$	Time between power on and the device being ready for new I ² C commands		18	20	ms
	Time after rising nRESET pin or giving the SW_RESET command and the device being ready for new I ² C commands		1	2	ms
t_{DWAKE}	Minimum time nWAKE should be high after rising nWAKE	20			μ s
t_{DRESET}	Minimum time nRESET should be high after rising nRESET	20			μ s
t_{RESET}	Minimum time nRESET should be low after falling nRESET	15			μ s
f_{I^2C}	Frequency of I ² C bus supported	10	100	400	kHz
t_{I^2C}	Clock stretch duration	0	1	100	ms

Note(s):

1. nWAKE should be asserted prior to and during any I²C transaction.
2. Up to 70ms on the first Reset after new application download.

Figure 8:
CCS811 Timings

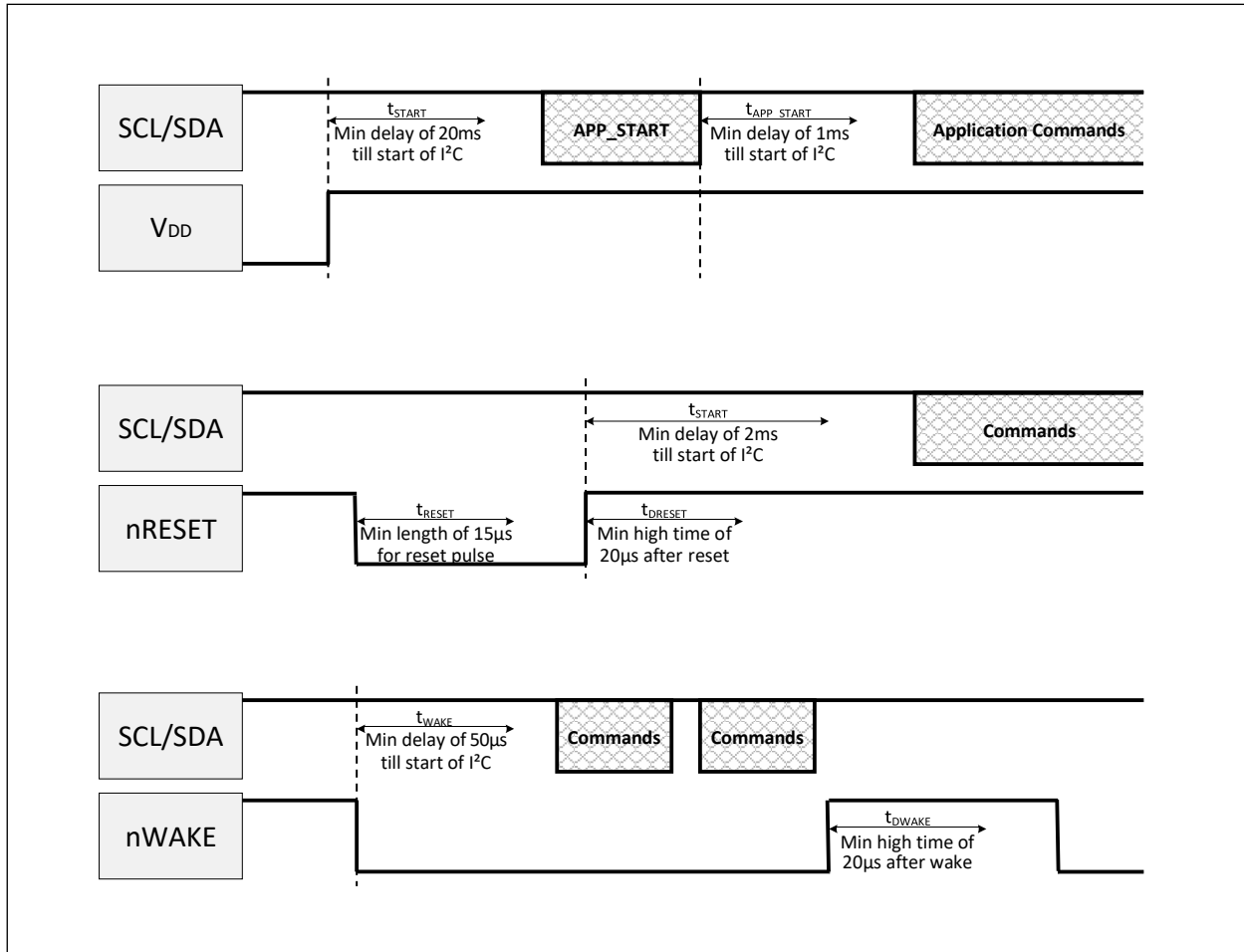

Detailed Description

State Machine

The state machine for CCS811 is shown below:

Figure 9:
CCS811 State Machine

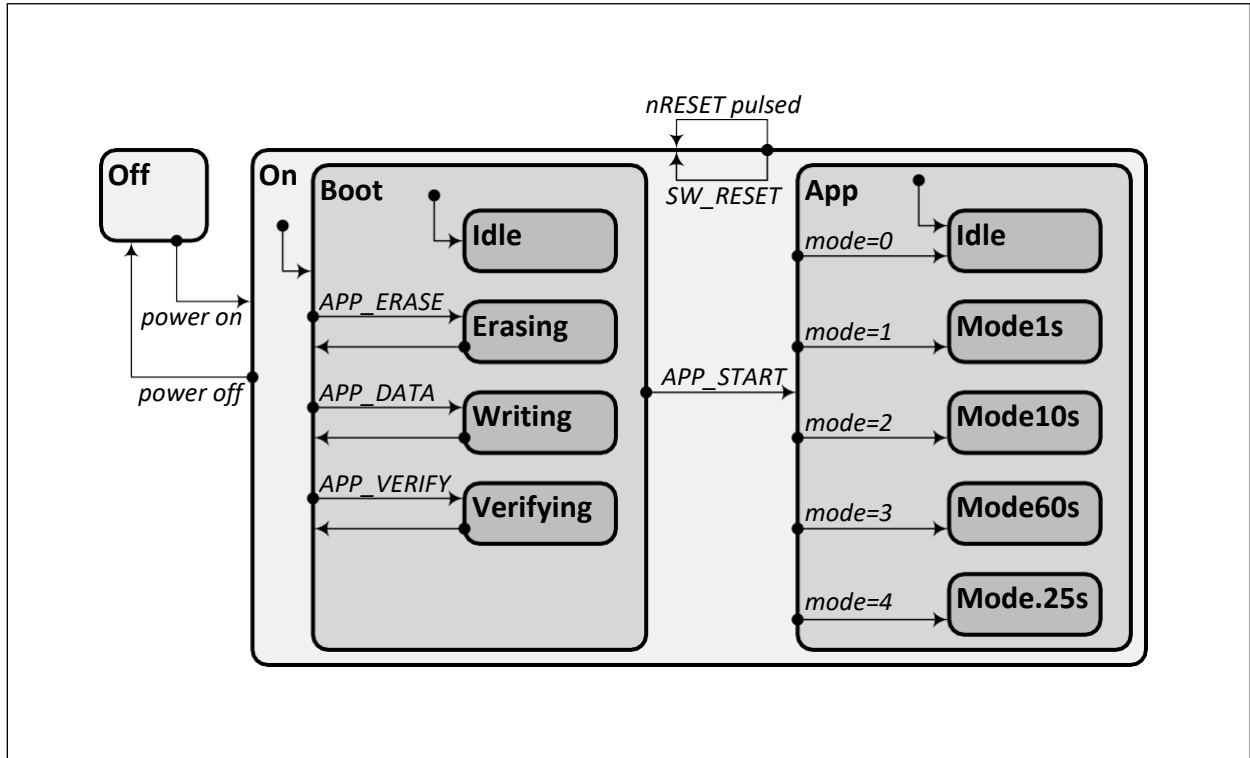

When powering on the CCS811, a typical action is to transition from *Boot* to *App* mode, a write to register APP_START with no data is required. Before performing the write the STATUS register should be accessed to check if there is an application present. When in *App* mode, the next step is to start measuring. For example, writing 1 to register MEAS_MODE selects operation mode *Mode1s*: every second new measurement data (CO₂, TVOC) becomes available.

A write to register SW_RESET (with a four byte “cookie”) will restart the CCS811 in *Boot* mode. The key feature of the *Boot* mode is replacement of the application firmware. First erase the application firmware (write to APP_ERASE), next write the new firmware image (use multiple 8 byte writes via APP_DATA), and finally verify the written firmware (with a write to APP_VERIFY).

For details on these registers, see later sections in this datasheet.

Power States

The previous diagram showed that when the CCS811 is powered *On* it can be in several functional states (e.g. *App* with *Mode1s*). Orthogonal to this, when the CCS811 is *On*, it can be in several power states. The diagram below illustrates the power behavior.

Figure 10:
CCS811 Power States

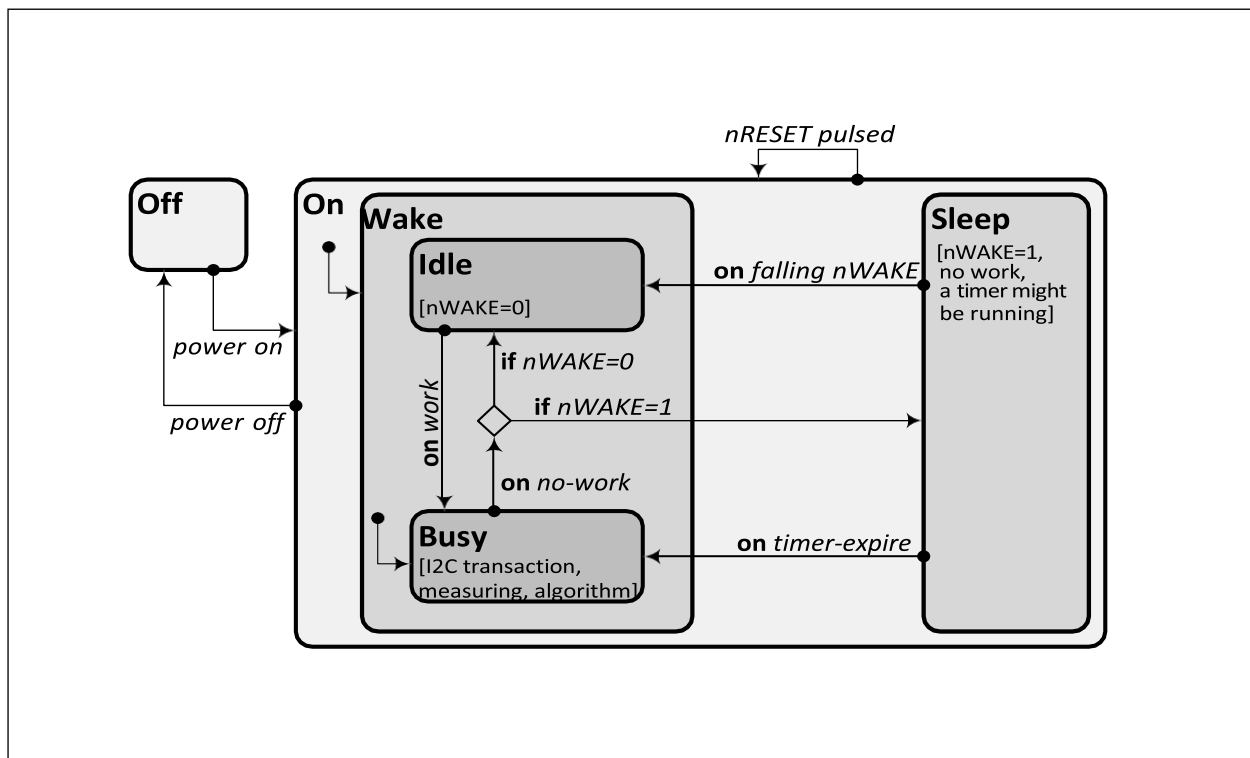

As long as the CCS811 has work to do, for example, handling I²C transactions from the master, executing a measurement or running algorithms to convert measurement to eCO₂/eTVOC, the CCS811 is *Busy*. When measurements are enabled a timer is running (which expires every 1, 10, 60 or 0.25 seconds), but running a timer does not count as work.

When there is no work to do, the power state transitions from *Busy* to either *Idle* or *Sleep*, depending on the state of the nWAKE pin. With nWAKE high, the master requests *Sleep* mode, with nWAKE low, the CCS811 stays *Wake* but *Idle*.

In *Idle* mode, work can appear, either an I²C transaction from the host, or the timer expires, triggering a measurement (followed by an algorithm step).

In *Sleep* mode the CCS811 is not ready to handle I²C transactions. The master should first pull nWAKE low, this causes the CCS811 to transition to *Wake (Idle)*. A timer could be running, when it expires, it also causes the CCS811 to transition to *Wake*, but as *Busy*.

Note that a hardware reset (via the nRESET) pin can be triggered irrespective of the power state (assuming *On*), for a SW_RESET, the CCS811 needs to be *Wake*.

So, tying nWAKE to ground is the simplest hardware configuration – CCS811 will always be *Wake* and ready to communicate but consumes more power. If power consumption is a concern, the master should set nWAKE low before I²C communication and high afterwards. If measurements are enabled, the CCS811 will use a timer to wake up itself periodically to execute a measurement.

Modes of Operation

The CCS811 has 5 modes of operation as follows

- Mode 0: Idle, low current mode
- Mode 1: Constant power mode, IAQ measurement every second
- Mode 2: Pulse heating mode IAQ measurement every 10 seconds
- Mode 3: Low power pulse heating mode IAQ measurement every 60 seconds
- Mode 4: Constant power mode, sensor measurement every 250ms

In Modes 1, 2, 3, the equivalent CO₂ concentration (ppm) and eTVOC concentration (ppb) are calculated for every sample.

- Mode 1 reacts fastest to gas presence, but has a higher operating current
- Mode 3 reacts more slowly to gas presence but has the lowest average operating current.

When a sensor operating mode is changed to a new mode with a lower sample rate (e.g. from Mode 1 to Mode 3), it should be placed in Mode 0 (Idle) for at least 10 minutes before enabling the new mode. When a sensor operating mode is changed to a new mode with a higher sample rate (e.g. from Mode 3 to Mode 1), there is no requirement to wait before enabling the new mode.

Mode 4 is intended for systems where an external host system wants to run an algorithm with raw data and this mode provides new sample data every 250ms. Mode 4 is also recommended for end-of-line production test to save test time. For additional information please refer to application note ScioSense AN000373: CCS811 Factory test procedure.

Note(s): Mode timings are subject to typical 2% tolerance due to accuracy of internal clock

Early-Life (Burn-In)

CCS811 performance in terms of resistance levels and sensitivities will change during early life. The change in resistance is greatest over the first 48 hours of operation. CCS811 controls the burn-in period allowing eCO₂ and eTVOC readings to be used from first power-on after 60 minutes of operation in modes 1-3.

Conditioning Period (Run-In)

After early-life (Burn-In) the conditioning or run-in period is the time required to achieve good sensor stability before measuring VOCs after long idle period.

After writing to MEAS_MODE to configure the sensor in mode 1-4, run CCS811 for 20 minutes, before accurate readings are generated.

The conditioning period must also be observed before writing to the BASELINE register.

eCO₂

The equivalent CO₂ (eCO₂) output range for CCS811 is from 400ppm up to 32768ppm.

eTVOC

The equivalent Total Volatile Organic Compound (eTVOC) output range for CCS811 is from 0ppb up to 29206ppb.

Temperature and Humidity Compensation

If an external sensor is available this information can be written to CCS811 so that they will be used to compensate gas readings due to temperature and humidity changes. When ENV_DATA has been written, the next eCO₂ and eTVOC readings (in ALG_RESULT_DATA) may not yet use the latest ENV_DATA. All subsequent reading will use the ALG_RESULT_DATA. *Refer to the [ENV_DATA \(Environment Data\) Register \(0x05\)](#).*

Interrupt and Interrupt on Threshold

At the end of each measurement cycle (250ms, 1s, 10s, 60s) a flag is set and optionally interrupt (nINT) pin asserted. *Refer to the [MEAS_MODE \(Measurement and Conditions\) Register \(0x01\)](#).* The user can choose to only assert nINT if the eCO₂ value changes into a different range set by register values. *Refer to the [THRESHOLDS Register \(0x10\)](#).*

Automatic Baseline Correction

The resistance R_S of the sensitive layer is the output of the sensor. However, metal oxide sensors do not give absolute readings. The resistance R_S varies from sensor to sensor (manufacturing variation), from use-case to use-case, and over time. To mitigate this problem, the output of the sensor is normalized: R_S is divided by R_A . The value of R_A is known as the baseline. R_A cannot be determined by a one-time calibration; it is maintained on-the-fly in software. This process is known as baseline correction. The air quality is expected to vary in a typical environment so the minimum time over which a baseline correction is applied is 24 hours. Automatic baseline correction is enabled after initial device operation.

Manual Baseline Correction

There is a mechanism within CCS811 to manually save and restore a previously saved baseline value using the BASELINE register.

For additional information on manual baseline control please refer to application note ScioSense AN000370: CCS811 Clean Air Baseline Save and Restore.

Application Information

The recommended application circuit for CCS811 is shown below.

Figure 11:
Recommended Application Circuit

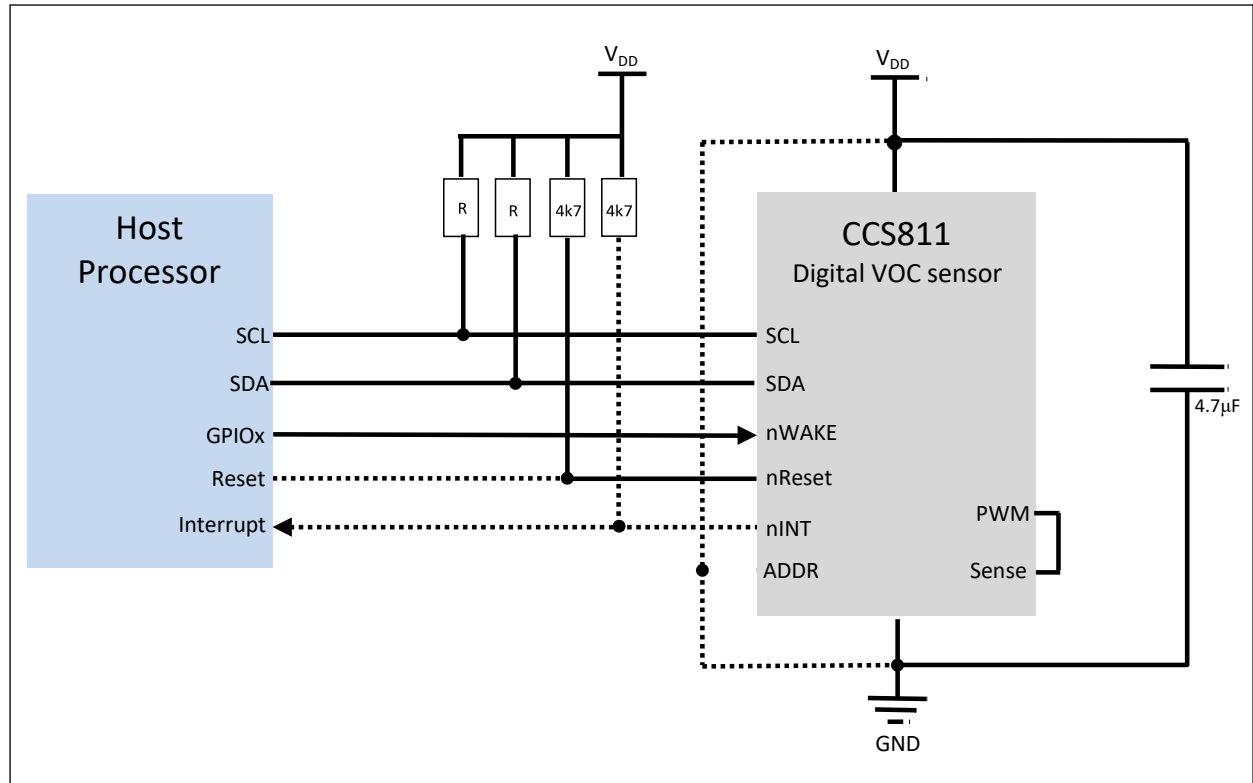

Note(s):

1. The PWM (Pin 4) and Sense (Pin 5) signals on CCS811 must be connected together.
2. A decoupling capacitor must be placed close to the supply pin VDD on the CCS811.
3. The value of the pull-ups for SCL and SDA depends on the system configuration (desired bus speed, bus length, number of slaves, etc.).
4. If power is not an issue, nWake can be connected to ground if a spare GPIO is not available on the host processor.
5. ADDR must be connected to either VDD (logic 1) or ground (logic 0) depending on the required lsb of the CCS811's I²C slave address.

Host System Software Requirements

1. The minimum level of driver support that a host system needs is read and write I²C transactions of data bytes where the nWAKE pin is asserted at least tAWAKE before the transaction and kept asserted throughout.
2. An Interrupt handler is also recommended to tell the application code that the device has asserted an interrupt.

I²C Interface

I²C transactions require a register address to be selected (written) and followed by data, as described by the transaction types in the subsections below. Each Register location corresponds to a byte or multiple bytes. Multiple reads or writes in a single sequence will be to or from the same location (the address does not increment). Therefore, registers are sometimes referred to as mailboxes in this document.

CCS811 requires the host processor supports clock stretching.

I²C Register Write

Figure 12:
I²C Register Write

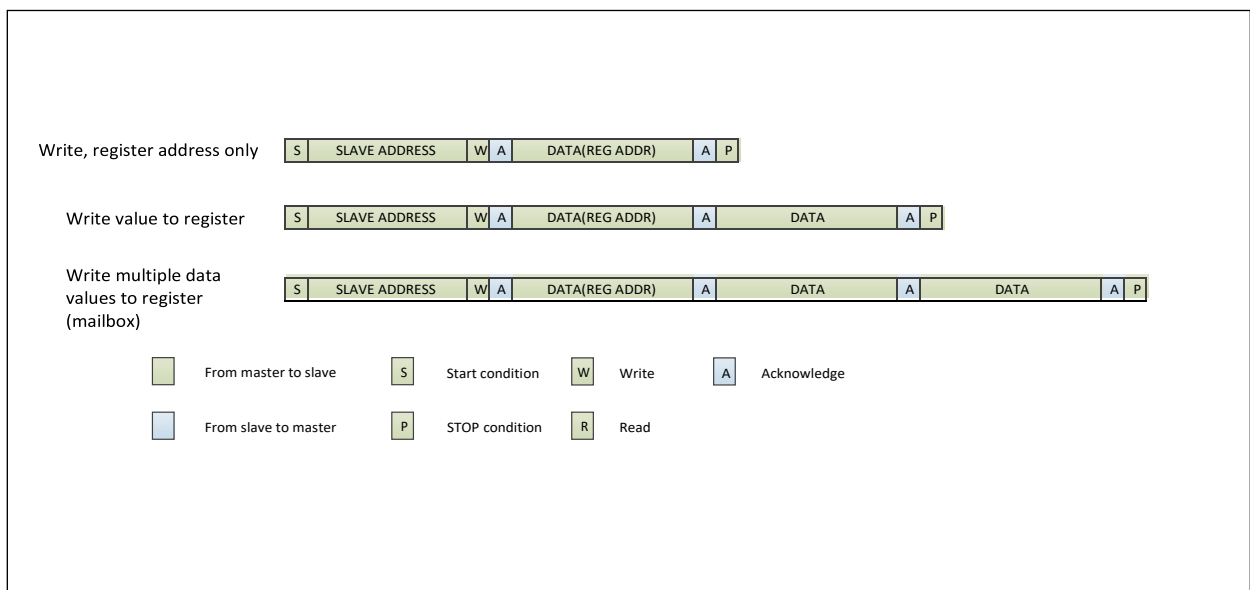

As shown above, a transaction may be:

- Single Byte to select a register address for subsequent read
- Two Bytes to select a register address and write a byte to it, typically to set a single-byte register value
- Multi-Bytes to select a register address and write several bytes to it, typically to set multiple configuration bytes

I²C Register Read

Figure 13:
I²C Register Read



- Since no register address can be supplied during an I²C read, an I²C write needs to be prepended to select the required register first.
- The write and read operations can optionally be combined into a single transaction using a repeated start condition, as shown in the second example above.
- Select and repeatedly read multiple data values from register, if the three reads are from the same register (mailbox), or from three subsequent registers (mailboxes).

Application Register Overview

All I²C transactions must use the (7 bits) slave address 0x5A or 0x5B depending on status of ADDR pin when writing to and reading from the CCS811. [Figure 14](#) shows the register map for CCS811. [Figure 25](#) shows the bootloader register map.

Figure 14:
CCS811 Application Register Map

Address	Register	R/W	Size	Description
0x00	STATUS	R	1 byte	Status register
0x01	MEAS_MODE	R/W	1 byte	Measurement mode and conditions register
0x02	ALG_RESULT_DATA	R	up to 8 bytes	Algorithm result. The most significant 2 bytes contain a ppm estimate of the equivalent CO ₂ (eCO ₂) level, and the next two bytes contain a ppb estimate of the total VOC level.
0x03	RAW_DATA	R	2 bytes	Raw ADC data values for resistance and current source used.
0x05	ENV_DATA	W	4 bytes	Temperature and humidity data can be written to enable compensation
0x10	THRESHOLDS	W	4 bytes	Thresholds for operation when interrupts are only generated when eCO ₂ ppm crosses a threshold
0x11	BASELINE	R/W	2 bytes	The encoded current baseline value can be read. A previously saved encoded baseline can be written.
0x20	HW_ID	R	1 byte	Hardware ID. The value is 0x81
0x21	HW Version	R	1 byte	Hardware Version. The value is 0x1X
0x23	FW_Boot_Version	R	2 bytes	Firmware Boot Version. The first 2 bytes contain the firmware version number for the boot code.
0x24	FW_App_Version	R	2 bytes	Firmware Application Version. The first 2 bytes contain the firmware version number for the application code
0xA0	Internal_State	R	1 byte	Internal Status register
0xE0	ERROR_ID	R	1 byte	Error ID. When the status register reports an error its source is located in this register
0xFF	SW_RESET	W	4 bytes	If the correct 4 bytes (0x11 0xE5 0x72 0x8A) are written to this register in a single sequence the device will reset and return to BOOT mode.

Note(s):

1. The number of bytes read from a register must not exceed the size in this table.
2. For more information on CCS811 programming requirements please refer to SciSense application note AN000369.

STATUS Register (0x00)

Single byte read only register which indicates if a device is active, if new data is available or if an error occurred.

Figure 15:
Status Register

7	6	5	4	3	2	1	0
FW_MODE	APP_ERASE	APP_VERIFY	APP_VALID	DATA_READY	-	-	ERROR

Bit(s)	Field	Description
7	FW_MODE	0: Firmware is in boot mode, this allows new firmware to be loaded 1: Firmware is in application mode. CCS811 is ready to take ADC measurements
6	APP_ERASE	Boot Mode only. 0: No erase completed 1: Application erase operation completed successfully (flag is cleared by APP_DATA and also by APP_START, SW_RESET, nRESET and APP_VERIFY) After issuing the ERASE command the application software must wait 500ms before issuing any transactions to the CCS811 over the I ² C interface.
5	APP_VERIFY	Boot Mode only. 0: No verify completed 1: Application verify operation completed successfully (flag is cleared by APP_START, SW_RESET and nRESET) After issuing a VERIFY command the application software must wait 70ms before issuing any transactions to CCS811 over the I ² C interface
4	APP_VALID	0: No application firmware loaded 1: Valid application firmware loaded
3	DATA_READY	0: No new data samples are ready 1: A new data sample is ready in ALG_RESULT_DATA, this bit is cleared when ALG_RESULT_DATA is read on the I ² C interface
2:1	-	Reserved
0	ERROR	This bit is cleared by reading ERROR_ID (it is not sufficient to read the ERROR field of ALG_RESULT_DATA and STATUS) 0: No error has occurred 1: There is an error on the I ² C or sensor, the ERROR_ID register (0xE0) contains the error source

MEAS_MODE (Measurement and Conditions) Register (0x01)

This is Single byte register, which is used to enable sensor drive mode and interrupts.

Figure 16:
Measure Mode Register

7	6	5	4	3	2	1	0
-	DRIVE_MODE			INTERRUPT	THRESH	-	

Bit(s)	Field	Description
7	-	Reserved – write ‘0’
6:4	DRIVE_MODE	000: Mode 0 – Idle (Measurements are disabled in this mode) 001: Mode 1 – Constant power mode, IAQ measurement every second 010: Mode 2 – Pulse heating mode IAQ measurement every 10 seconds 011: Mode 3 – Low power pulse heating mode IAQ measurement every 60 seconds 100: Mode 4 – Constant power mode, sensor measurement every 250ms 1xx: Reserved modes (For future use) In mode 4, the ALG_RESULT_DATA is not updated, only RAW_DATA; the processing must be done on the host system. A new sample is placed in ALG_RESULT_DATA and RAW_DATA registers and the DATA_READY bit in the STATUS register is set at the defined measurement interval.
3	INT_DATARDY	0: Interrupt generation is disabled 1: The nINT signal is asserted (driven low) when a new sample is ready in ALG_RESULT_DATA. The nINT signal will stop being driven low when ALG_RESULT_DATA is read on the I ² C interface. At the end of each measurement cycle (250ms, 1s, 10s, 60s) a flag is set in the STATUS register regardless of the setting of this bit..
2	INT_THRESH	0: Interrupt mode (if enabled) operates normally 1: Interrupt mode (if enabled) only asserts the nINT signal (driven low) if the new ALG_RESULT_DATA crosses one of the thresholds set in the THRESHOLDS register by more than the hysteresis value (also in the THRESHOLDS register)
1:0	-	Reserved - write 00

ALG_RESULT_DATA (Algorithm Results Data) Register (0x02)

This multi-byte read only register contains the calculated eCO₂ (ppm) and eTVOC (ppb) values followed by the STATUS register, ERROR_ID register and the RAW_DATA register.

- If only eCO₂ is required, only the first 2 bytes need to be read.
- If eTVOC is required, 4 bytes need to be read.
- In a system where interrupts are not implemented and the host needs to poll the STATUS register to determine whether there is new data, an efficient alternative is to read 5 bytes in a single transaction since that returns eCO₂, eTVOC and the status register.
- Optionally, all 8 bytes could be read in a single transaction, so that even the error status and the raw data is available.

Figure 17:
Algorithm Results Register Byte Order

Byte 0	Byte 1	Byte 2	Byte 3	Byte 4	Byte 5	Byte 6 & 7
eCO ₂ High Byte	eCO ₂ Low Byte	eTVOC High Byte	eTVOC Low Byte	STATUS	ERROR_ID	See RAW_DATA

RAW_DATA Register (0x03)

Two byte read only register which contains the latest readings from the sensor.

The most significant 6 bits of the Byte 0 contain the value of the current through the sensor (0μA to 63μA).

The lower 10 bits contain (as computed from the ADC) the readings of the voltage across the sensor with the selected current (1023 = 1.65V)

Figure 18:
RAW_DATA Register Byte Order

Byte 0								Byte 1							
7	6	5	4	3	2	1	0	7	6	5	4	3	2	1	0
Current Selected 5:0							Raw ADC reading 9:0								

ENV_DATA (Environment Data) Register (0x05)

A multi-byte register that can be written with the current Humidity and Temperature values if known.

Relative Humidity

Figure 19:
Relative Humidity Fields and Byte Order

Byte 0								Byte 1							
Humidity High Byte								Humidity Low Byte							
7	6	5	4	3	2	1	0	7	6	5	4	3	2	1	0
64	32	16	8	4	2	1	1/2	1/4	1/8	1/16	1/32	1/64	1/128	1/256	1/512
Humidity %								Humidity % Fraction							

Humidity is stored as an unsigned 16 bits in 1/512%RH. The default value is 50% = 0x64, 0x00. As an example 48.5% humidity would be 0x61, 0x00.

Temperature

Figure 20:
Temperature Fields and Byte Order

Byte 2								Byte 3							
Temperature High Byte								Temperature Low Byte							
7	6	5	4	3	2	1	0	7	6	5	4	3	2	1	0
64	32	16	8	4	2	1	1/2	1/4	1/8	1/16	1/32	1/64	1/128	1/256	1/512
Temperature 25°C								Temperature 25°C Fraction							

Temperature is stored as an unsigned 16 bits integer in 1/512 degrees; there is an offset: 0 maps to -25°C. The default value is 25°C = 0x64, 0x00. As an example 23.5% temperature would be 0x61, 0x00.

The internal algorithm uses ENV_DATA values (or default values if not set by the application) to compensate for changes in relative humidity and ambient temperature.

For temperatures below -25°C the 7-bit temperature field in Byte 2 above should be set to all zeros.

THRESHOLDS Register (0x10)

If 'interrupt on threshold change' has been set in the Mode register (see above), the values in this multi-byte write only register are used to determine the thresholds.

Figure 21:
Thresholds Register Byte Order

Byte 0	Byte 1	Byte 2	Byte 3
Low to Medium Threshold		Medium to High Threshold	
High Byte	Low Byte	High Byte	Low Byte

An interrupt is asserted if the eCO₂ value moved from the current range (Low, Medium, or High) into another range by more than 50ppm.

- Low to Medium Threshold default = 1500ppm = 0x05DC
- Medium to High Threshold default = 2500ppm = 0x09C4

BASELINE Register (0x11)

A two byte read/write register which contains an encoded version of the current baseline used in Algorithm Calculations.

A previously stored value may be written back to this two byte register and the Algorithms will use the new value in its calculations (until it adjusts it as part of its internal Automatic Baseline Correction). For more information, refer to SciSense application note AN000370: CCS811 Clean Air Baseline Save and Restore.

HW_ID (Hardware identifier) Register (0x20)

Single byte read only register which holds the HW ID which is 0x81 for this family of CCS81x devices.

HW_Version (Hardware Version) Register (0x21)

Single byte read only register which holds the Hardware Major and Minor Hardware versions.

The top four bits read major hardware version 1 – identifying the product as CCS811. The bottom four bits identify any build variant. The default value is 0x1X.

FW_Boot_Version (Firmware Bootloader Version) Register (0x23)

Two byte read only register which contain the version of the firmware bootloader stored in the CCS811 in the format Major.Minor.Trivial

Figure 22:
Firmware Bootloader Version Format

Byte 0								Byte 1							
7	6	5	4	3	2	1	0	7	6	5	4	3	2	1	0
Major				Minor				Trivial							

FW_App_Version (Firmware Application Version) Register (0x24)

Two byte read only register which contain the version of the firmware application stored in the CCS811 in the format Major.Minor.Trivial. FW_App_Version will read FFFF when there is no firmware application (see [APP_VALID](#) in STATUS).

Figure 23:
Firmware Application Version Format

Byte 0								Byte 1							
7	6	5	4	3	2	1	0	7	6	5	4	3	2	1	0
Major				Minor				Trivial							

ERROR_ID (Error Identifier) Register (0xE0)

If the ERR bit [0] of the STATUS Register is set, this single byte read only register indicates source(s) of the error.

Figure 24:
ERROR_ID Register Codes

Bit	ERROR_CODE	Description
0	WRITE_REG_INVALID	The CCS811 received an I ² C write request addressed to this station but with invalid register address ID
1	READ_REG_INVALID	The CCS811 received an I ² C read request to a mailbox ID that is invalid
2	MEASMODE_INVALID	The CCS811 received an I ² C request to write an unsupported mode to MEAS_MODE
3	MAX_RESISTANCE	The sensor resistance measurement has reached or exceeded the maximum range
4	HEATER_FAULT	The Heater current in the CCS811 is not in range
5	HEATER_SUPPLY	The Heater voltage is not being applied correctly
6	-	Reserved for Future Use
7	-	Reserved for Future Use

SW_RESET Register (0xFF)

As an alternative to Power-On reset or Hardware Reset a Software Reset is available.

Asserting the SW_RESET will restart the CCS811 in Boot mode to enable new application firmware to be downloaded.

To prevent accidental SW_RESET a sequence of four bytes must be written to this register in a single I²C sequence: 0x11, 0xE5, 0x72, 0x8A.

For details, please refer to application notes SciSense AN000369 and SciSense AN000371.

Bootloader Register Overview

All I²C transactions must use the (7bits) slave address 0x5A or 0x5B depending on status of ADDR pin when writing to and reading from the CCS811. [Figure 25](#) shows the bootloader register map for CCS811.

Figure 25:
CCS811 Bootloader Register Map

Address	Register	R/W	Size	Description
0x00	STATUS	R	1 byte	Status register
0x20	HW_ID	R	1 byte	Hardware ID. The value is 0x81
0x21	HW_Version	R	1 byte	Hardware Version. The value is 0x1X
0x23	FW_Boot_Version	R	2 bytes	Firmware Boot Version. The first 2 bytes contain the firmware version number for the boot code.
0x24	FW_App_Version	R	2 bytes	Firmware Application Version. The first 2 bytes contain the firmware version number for the application code.
0xE0	ERROR_ID	R	1 byte	Error ID. When the status register reports an error its source is located in this register
0xF1	APP_ERASE	W	4 bytes	If the correct 4 bytes (0xE7 0xA7 0xE6 0x09) are written to this register in a single sequence the device will start the application erase
0xF2	APP_DATA	W	9 bytes	Transmit flash code for the bootloader to write to the application flash code space.
0xF3	APP_VERIFY	W	-	Starts the process of the bootloader checking through the application to make sure a full image is valid.
0xF4	APP_START	W	-	Application start. Used to transition the CCS811 state from boot to application mode, a write with no data is required. Before performing a write to APP_START the Status register should be accessed to check if there is a valid application present.
0xFF	SW_RESET	W	4 bytes	If the correct 4 bytes (0x11 0xE5 0x72 0x8A) are written to this register in a single sequence the device will reset and return to BOOT mode.

Note(s):

1. The number of bytes read from a register must not exceed the size in this table.
2. For more information on performing application code download please refer to application note SciSense AN000371.

Registers not detailed below are documented in the [Application Register Overview](#) section.

APP_ERASE (Application Erase) Register (0xF1) To prevent accidental APP_ERASE a sequence of four bytes must be written to this register in a single I²C sequence: 0xE7, 0xA7, 0xE6, 0x09.

The APP_ERASE can take a variable amount of time. The status register can be polled to determine when this function is complete. The 6th bit (0x40) is initialised to 0 and set to a 1 on completion of the APP_ERASE function. After an erase this bit is only cleared by doing a reset or starting the application.

APP_DATA (Application Data) Register (0xF2)

Nine byte, write only register for sending small chunks of application data which will be written in order to the CCS811 flash code.

APP_VERIFY (Application Verify) Register (0xF3)

Single byte write only register which starts the application verify process run by the bootloader to check for a complete application code image. Command only needs to be called once after a firmware download as the result is saved in a flash location that gets checked during device initialisation.

The APP_VERIFY can take a variable amount of time. The status register can be polled to determine when this function is complete. The 5th bit (0x20) is initialised to 0 and set to a 1 on completion of the APP_VERIFY function. After an APP_VERIFY this bit is only cleared by doing a reset or starting the application.

For details on downloading new application firmware please refer to application note SciSense AN000371.

APP_START (Application Start) Register (0xF4)

To change the mode of the CCS811 from Boot mode to running the application, a single byte write of 0xF4 is required.

The CCS811 interprets this as an address write to select the 'APP_START' register and starts running the loaded application software if it is a valid version (*Refer to the [STATUS Register \(0x00\)](#)*).

Package Drawings & Marking

LGA Package Outline

Figure 26:
LGA Package Drawings

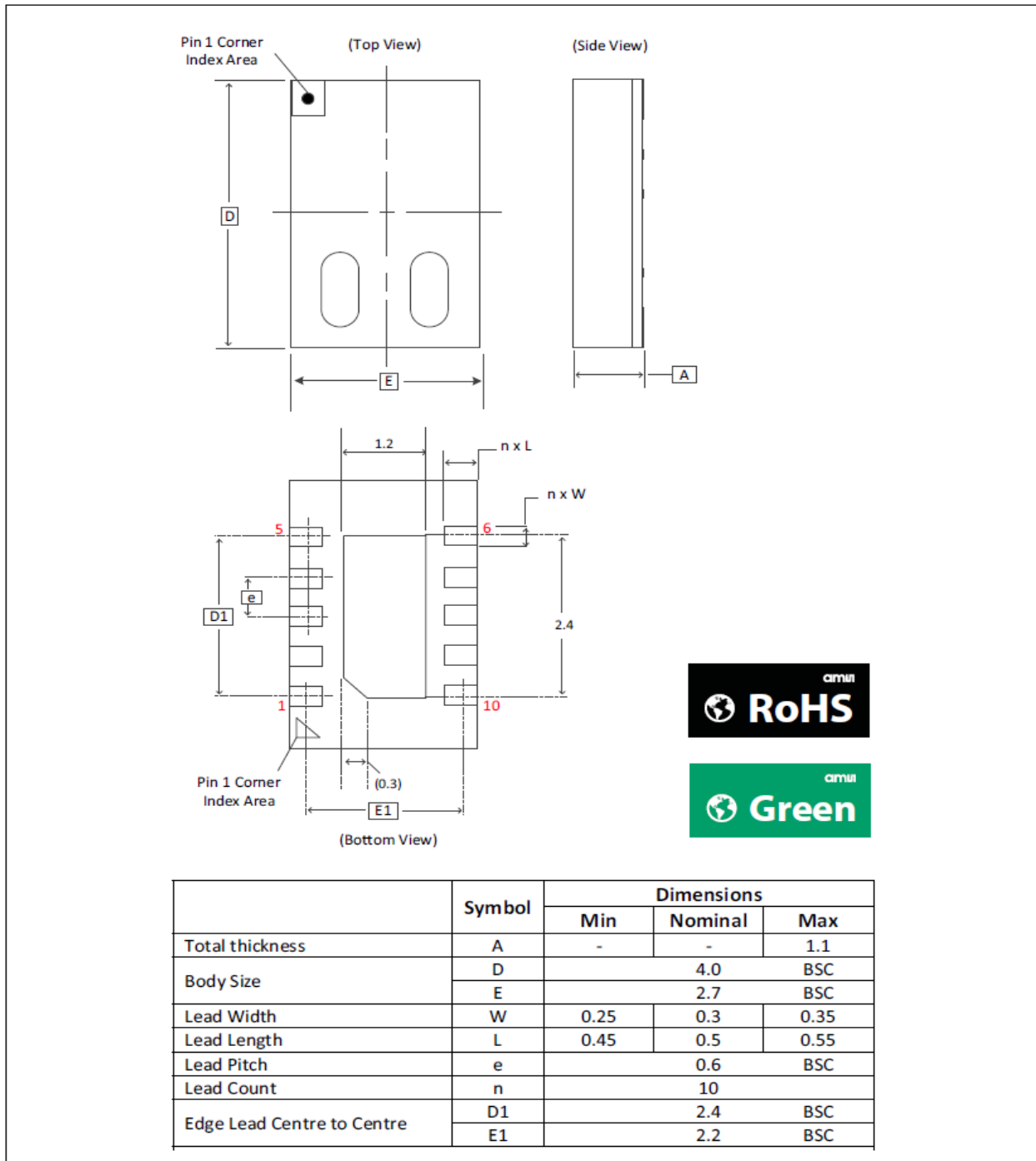

Note(s):

1. All dimensions are in millimeters.

The recommended package footprint or landing pattern for CCS811 is shown below:

Figure 27:
Recommended Package Footprint for CCS811

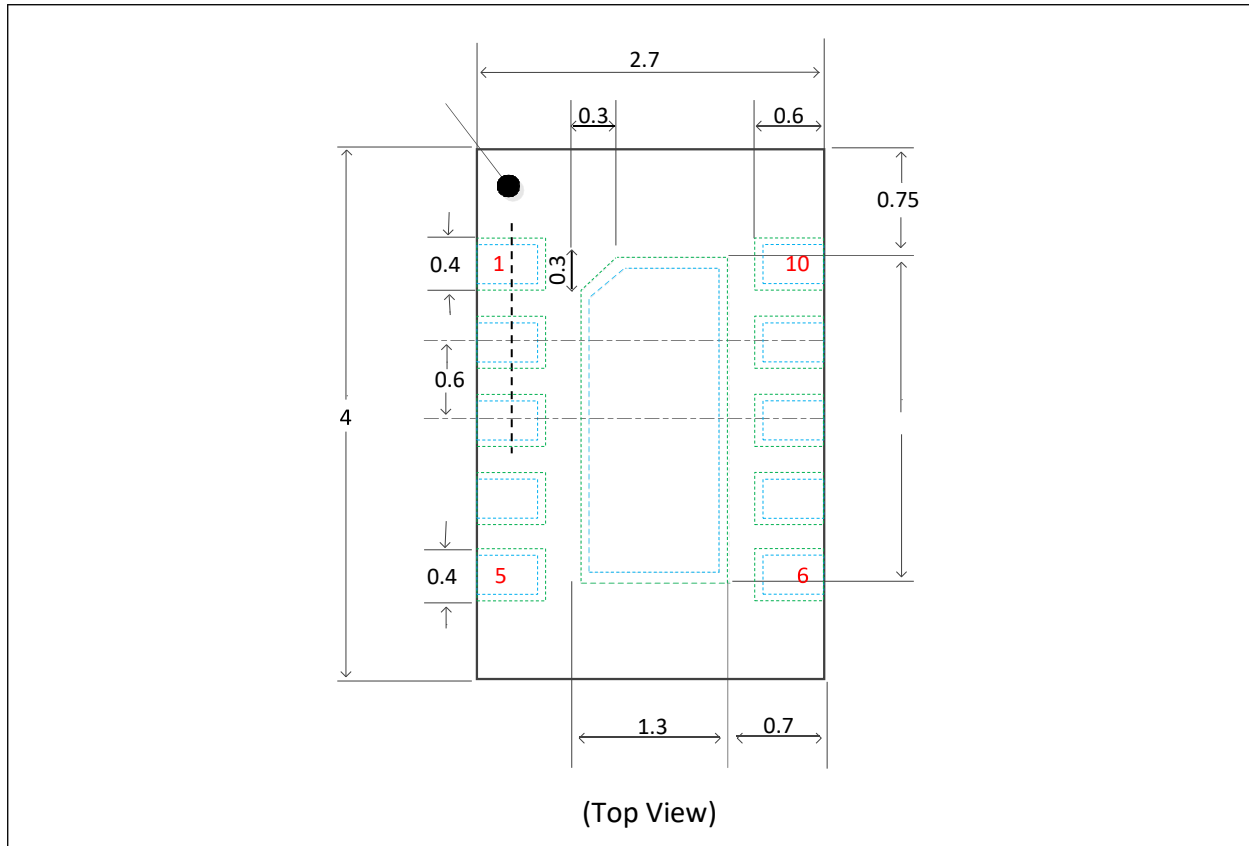

Note(s):

1. All dimensions are in millimeters.
2. PCB land pattern in Green dash lines
3. Pin numbers are in Red
4. Add 0.05mm all around the nominal lead width and length for the PCB land pattern

Ordering & Contact Information

Figure 28:
Ordering Information

Ordering Code	Description	Package	MOQ
CCS811B-JOPR5K	CCS811 digital gas sensor for Indoor Air Quality Monitoring	2.7mm x 4.0mm x 1.1mm LGA	5000
CCS811B-JOPD500	CCS811 digital gas sensor for Indoor Air Quality Monitoring	2.7mm x 4.0mm x 1.1mm LGA	500

Note(s):

1. Refer to JEDEC J-STD020 lead-free standard for typical soldering reflow profile

Technical Support is available at:

customersupport@sciosense.com

For further information and requests, e-mail us at:

info@sciosense.com

For sales offices, distributors and representatives, please visit:

www.sciosense.com/distribution-partners/

Headquarters

SciSense B.V.
High Tech Campus 10
5656 AE Eindhoven
The Netherlands

Tel: +43 (0) 3136 500 0

Website: www.sciosense.com

RoHS Compliant & ams Green Statement

RoHS: The term RoHS compliant means that ams AG products fully comply with current RoHS directives. Our semiconductor products do not contain any chemicals for all 6 substance categories, including the requirement that lead not exceed 0.1 % by weight in homogeneous materials. Where designed to be soldered at high temperatures, RoHS compliant products are suitable for use in specified lead-free processes.

ams Green (RoHS compliant and no Sb/Br): ams Green defines that in addition to RoHS compliance, our products are free of Bromine (Br) and Antimony (Sb) based flame retardants (Br or Sb do not exceed 0.1% by weight in homogeneous material).

Important Information: The information provided in this statement represents ams AG knowledge and belief as of the date that it is provided. ams AG bases its knowledge and belief on information provided by third parties, and makes no representation or warranty as to the accuracy of such information. Efforts are underway to better integrate information from third parties. ams AG has taken and continues to take reasonable steps to provide representative and accurate information but may not have conducted destructive testing or chemical analysis on incoming materials and chemicals. ams AG and ams AG suppliers consider certain information to be proprietary, and thus CAS numbers and other limited information may not be available for release.

Copyrights & Disclaimer

Copyright ams AG, Tobelbader Strasse 30, 8141 Premstaetten, Austria-Europe. Trademarks Registered. All rights reserved. The material herein may not be reproduced, adapted, merged, translated, stored, or used without the prior written consent of the copyright owner.

Devices sold by ams AG are covered by the warranty and patent indemnification provisions appearing in its General Terms of Trade. ams AG makes no warranty, express, statutory, implied, or by description regarding the information set forth herein. ams AG reserves the right to change specifications and prices at any time and without notice. Therefore, prior to designing this product into a system, it is necessary to check with ams AG for current information. This product is intended for use in commercial applications. Applications requiring extended temperature range, unusual environmental requirements, or high reliability applications, such as military, medical life-support or life-sustaining equipment are specifically not recommended without additional processing by ams AG for each application. This product is provided by ams AG "AS IS" and any express or implied warranties, including, but not limited to the implied warranties of merchantability and fitness for a particular purpose are disclaimed.

ams AG shall not be liable to recipient or any third party for any damages, including but not limited to personal injury, property damage, loss of profits, loss of use, interruption of business or indirect, special, incidental or consequential damages, of any kind, in connection with or arising out of the furnishing, performance or use of the technical data herein. No obligation or liability to recipient or any third party shall arise or flow out of ams AG rendering of technical or other services.

Document Status

Document Status	Product Status	Definition
Product Preview	Pre-Development	Information in this datasheet is based on product ideas in the planning phase of development. All specifications are design goals without any warranty and are subject to change without notice
Preliminary Datasheet	Pre-Production	Information in this datasheet is based on products in the design, validation or qualification phase of development. The performance and parameters shown in this document are preliminary without any warranty and are subject to change without notice
Datasheet	Production	Information in this datasheet is based on products in ramp-up to full production or full production which conform to specifications in accordance with the terms of ams AG standard warranty as given in the General Terms of Trade
Datasheet (discontinued)	Discontinued	Information in this datasheet is based on products which conform to specifications in accordance with the terms of ams AG standard warranty as given in the General Terms of Trade, but these products have been superseded and should not be used for new designs

Revision Information

Changes from 1-05 (2018-May-01) to current revision 1-07 (2020-Dec-16)	Page
Updated figure 6	6
Updated figure 7	7
Added figure 8	8
Added “State Machine” under “Detailed Description”	9
Added “Power States” under “Detailed Description”	10
Updated and Renamed “Early-Life Use (Burn-In)” to “Early-Life (Burn-In)”	12
Updated Conditioning Period (Run-In), eCO ₂ , Temperature and Humidity Compensation	12
eTVOC and eCO ₂ limits corrected	12
Updated figure 11 and notes under it	14
Updated figure 15	18
Updated “FW_App_Version (Firmware Application Version) Register (0x24)”	23
References to ams changed to SciSense	all

Note(s):

1. Page and figure numbers for the previous version may differ from page and figure numbers in the current revision.
2. Correction of typographical errors is not explicitly mentioned.

Appendix

References

Figure 29:
Document Reference

Document Reference	Description
SciSense AN000367	CCS811 Assembly guidelines
SciSense AN000368	CCS811 Design guidelines
SciSense AN000369	CCS811 Programming and interfacing guide
SciSense AN000370	CCS811 Clean air baseline save and restore
SciSense AN000371	CCS811 Performing a firmware download
SciSense AN000373	CCS811 Factory test procedure

Content Guide

- 1 General Description**
- 2 Key Benefits & Features
- 3 Applications
- 4 Block Diagram

- 5 Pin Assignment**
- 6 Absolute Maximum Ratings**
- 7 Electrical Characteristics**

- 9 Detailed Description**
- 9 State Machine
- 10 Power States
- 11 Modes of Operation
- 11 Early-Life (Burn-In)
- 12 Conditioning Period (Run-In)
- 12 eCO₂
- 12 eTVOC
- 12 Temperature and Humidity Compensation
- 12 Interrupt and Interrupt on Threshold
- 13 Automatic Baseline Correction
- 13 Manual Baseline Correction

- 14 Application Information**
- 14 Host System Software Requirements
- 15 I²C Interface
- 15 I²C Register Write
- 16 I²C Register Read

- 17 Application Register Overview**
- 18 STATUS Register (0x00)
- 19 MEAS_MODE (Measurement and Conditions) Register (0x01)
- 20 ALG_RESULT_DATA (Algorithm Results Data) Register (0x02)
- 20 RAW_DATA Register (0x03)
- 21 ENV_DATA (Environment Data) Register (0x05)
- 21 Relative Humidity
- 22 THRESHOLDS Register (0x10)
- 22 BASELINE Register (0x11)
- 22 HW_ID (Hardware identifier) Register (0x20)
- 22 HW_Version (Hardware Version) Register (0x21)
- 23 FW_Boot_Version (Firmware Bootloader Version) Register (0x23)
- 23 FW_App_Version (Firmware Application Version) Register (0x24)
- 24 ERROR_ID (Error Identifier) Register (0xE0)
- 25 SW_RESET Register (0xFF)

- 26 Bootloader Register Overview**
- 27 APP_ERASE (Application Erase) Register (0xF1)
- 27 APP_DATA (Application Data) Register (0xF2)
- 27 APP_VERIFY (Application Verify) Register (0xF3)
- 27 APP_START (Application Start) Register (0xF4)

28	Package Drawings & Marking
28	LGA Package Outline
30	Ordering & Contact Information
31	RoHS Compliant & ams GreenStatement
32	Copyrights & Disclaimer
33	Document Status
34	Revision Information
35	Appendix
35	References