

1. Scope

This document is applied to a magnetic sensor operating to ON/OFF when the sensor detects the magnetic field.

2. Part number

2-1 Part description Magnetic Sensor

2-2 Murata part number MRMS541E

3. Dimensions and schematics

3-1 Dimensions

3-1-1 Package outline drawing (Unit :mm)

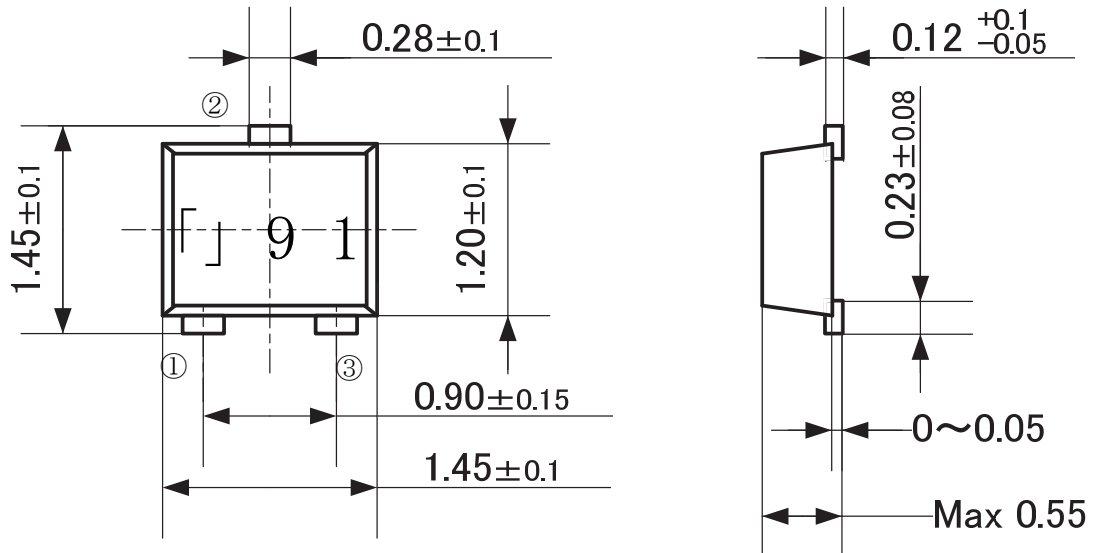

① :Vcc ② :Gnd ③ :Out

3-1-2 Marking example

(E.g.)	「」 9 1	I	Control code...One alphabetic character
	↓ ↓ ↓	II	Manufactured year...The last digit of the year
	I II III	III	Manufactured month..
			Jan to Sep : 1 to 9
			Oct to Dec : X, Y, Z

3-1-3 Reference mount pad (Unit :mm)

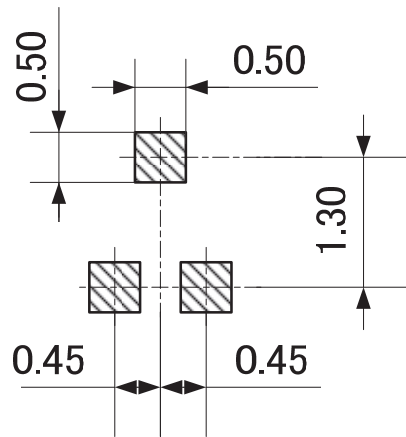

NOTE1) Please evaluate your soldering paset condition and reflow condition with our product being mounted to your product.

NOTE2) Please make sure the sensing direction of the sensor (see the item 3-2) and your magnetic field direction to the sensor.

3-2 Block wiring diagram

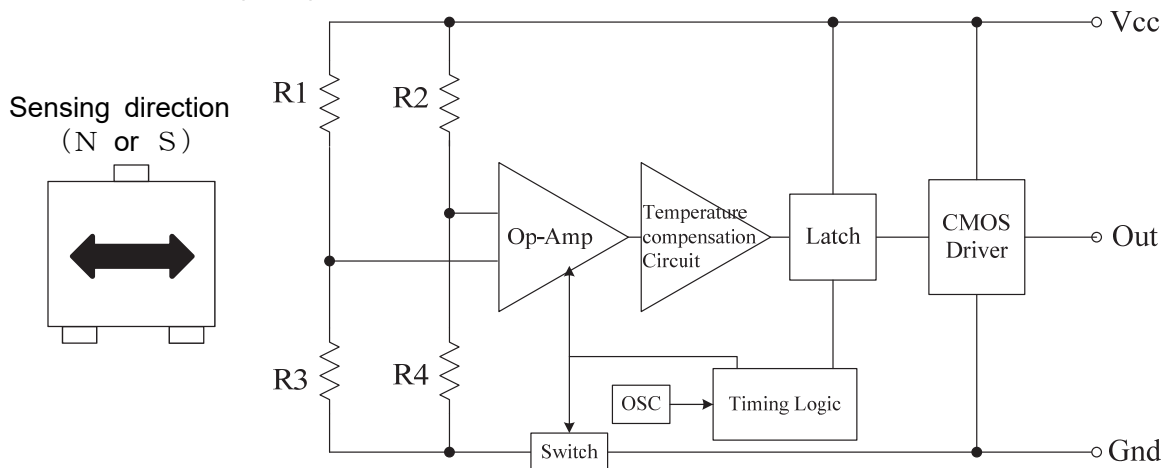

The intermittent switch circuit inside R1-R4:MR Elements

3-3 Magnetic electric conversion characteristic

ON/OFF switched depending on the intensity of the magnetic field. (Positive logic)

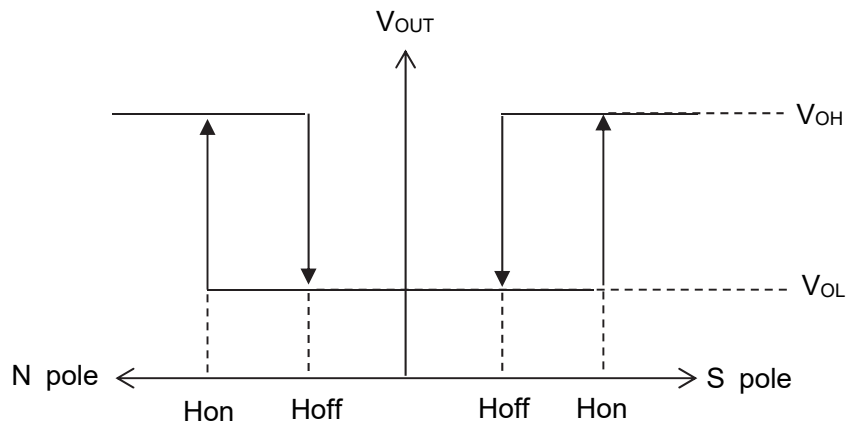

3-4 Timing diagram

The sensor has intermittence operating circuit.

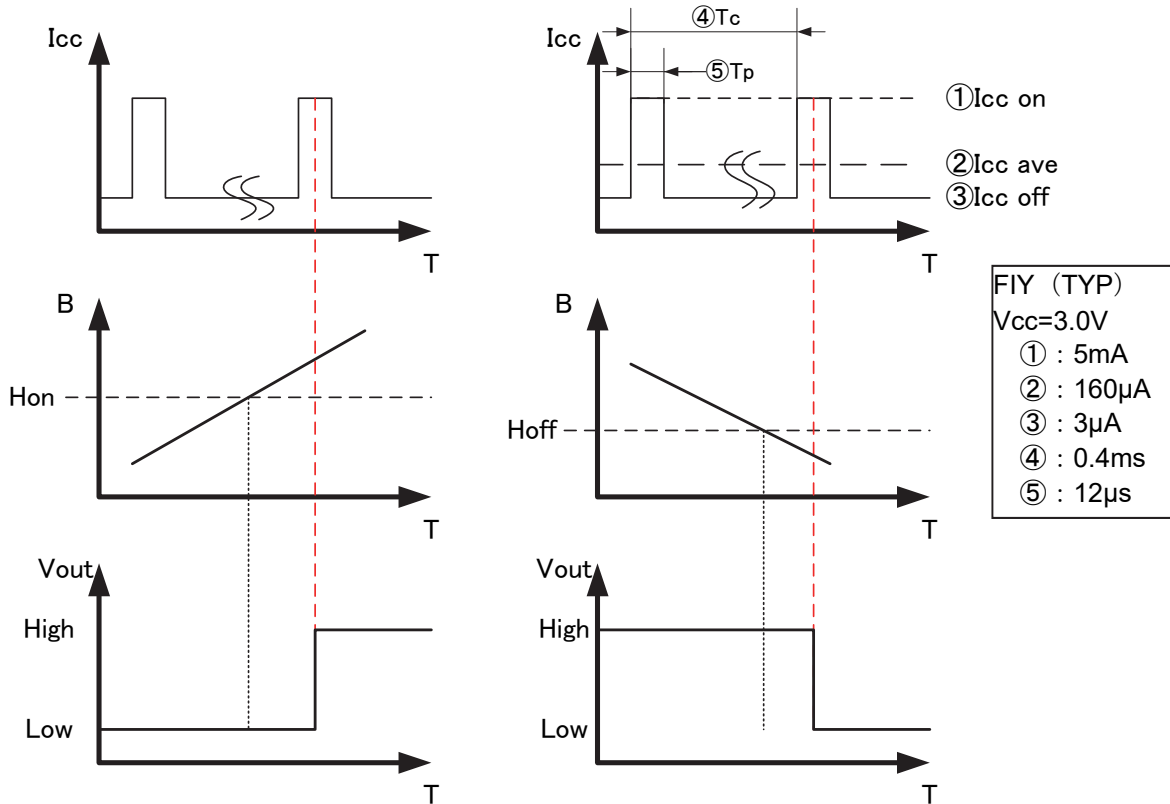

NOTE1) AMR element is driven by the intermittent switch circuit shown in item 3-2.

The timing of Vout change is subject to the period of Icc on.

NOTE2) Please consider the change speed of the operating magnetic field against the intermittent operation in your design process.

3-5 Electric characteristics/ absolute maximum rating (Ta=+25°C±3°C)

	Parameter	Symbol	Conditions	Min.	Typ.	Max.	Unit
1	Supply voltage	V _{cc}	—	2.4	3.0	3.8	V
2	Absolute max. supply voltage	—	—	—	—	6.0	V
3	Current consumption	I _{cc}	V _{cc} =3.0V No Load Resistance Average Current	—	160	250	µA
4	Operating magnetic field	H _{on}	V _{cc} =3.0V No Load Resistance	1.5	—	2.7	mT
		H _{off}	V _{cc} =3.0V No Load Resistance	0.9	—	—	
5	Frequency response	—	V _{cc} =3.0V No Load Resistance	1.0	2.0	—	kHz
6	Output Voltage	V _{OH}	V _{cc} =3.0V No Load Resistance	2.7	—	—	V
		V _{OL}	V _{cc} =3.0V No Load Resistance	—	—	0.3	V
7	Operating temp. range	—	—	-40	—	+85	°C
8	Storage temp. range	—	—	-40	—	+125	°C

NOTE1) Each specification represents the standardized figures tested independently.

NOTE2) When switching the sensor output from L to H, please make sure that the magnetic flux density applied to the sensor becomes higher than above stated operating magnetic field (H_{on}) in your designing process.

NOTE3) When switching the sensor output from H to L, please make sure that the magnetic flux density applied to the sensor becomes lower than above stated operating magnetic field (Hoff) in your designing process.

NOTE4) As the above stated operating magnetic field is defined based on Vcc=3.0V, please be advised that such operating magnetic field may vary under the condition of Vcc not equal to 3.0V. Therefore, please make sure to consider extra allowance in terms of the magnetic design, especially when the operating magnetic field is not defined at Vcc=3.0V.

4. Packing specification

4-1 Packing information

Form of packing	Reel dimension	Pcs per reel
Tape & reel	φ180	3000pcs

4-2 Taping specifications

4-2-1 Taping dimensions

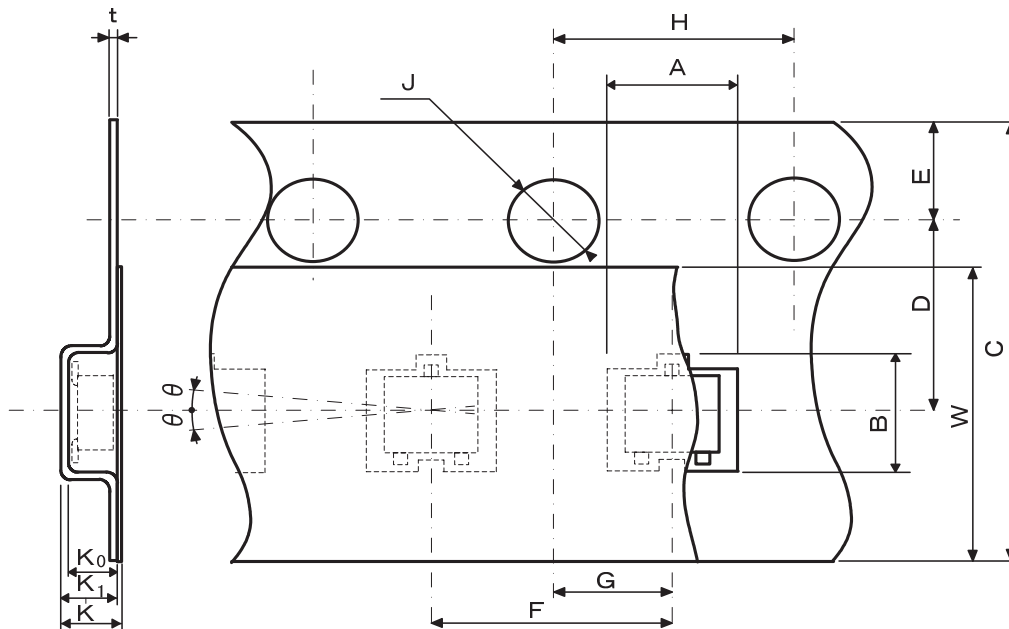

Unit:mm

Parameter	Symbol	Size/ Angle	Parameter	Symbol	Size/ Angle
Pocket	Length	A	Dist. Between center lines	L direction	G
	Width	B		W direction	D
	Depth	K ₀	Cover tape	Width	W
	Pitch	F		Width	C
Feed hole	Diameter	J	Carrier tape	Thickness	T
	Pitch	H		Depth	K ₁
	Position	E	Device	Tilt	θ
Overall thickness	K				

4-2-2 Reel dimensions...EIAJ PRV08B compliant

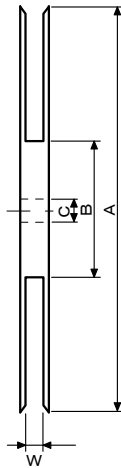
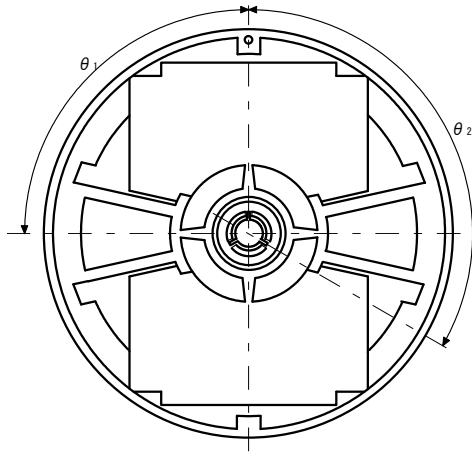

Unit: mm

Item	Symbol	Dim/Angle
Flange	Diameter	A $\phi 178 \pm 2$
	Dis. between flanges	W 9 ± 0.5
Hub	Diameter	B $\phi 60 \pm 1$
	Hub slit position	θ_1 90°
	Spindle hole diam.	C $\phi 13 \pm 0.5$
	Key slit position	θ_2 120°
Marking	Labeled on one side of flange	

4-2-3 Start/End of taping



Reel label A (example)

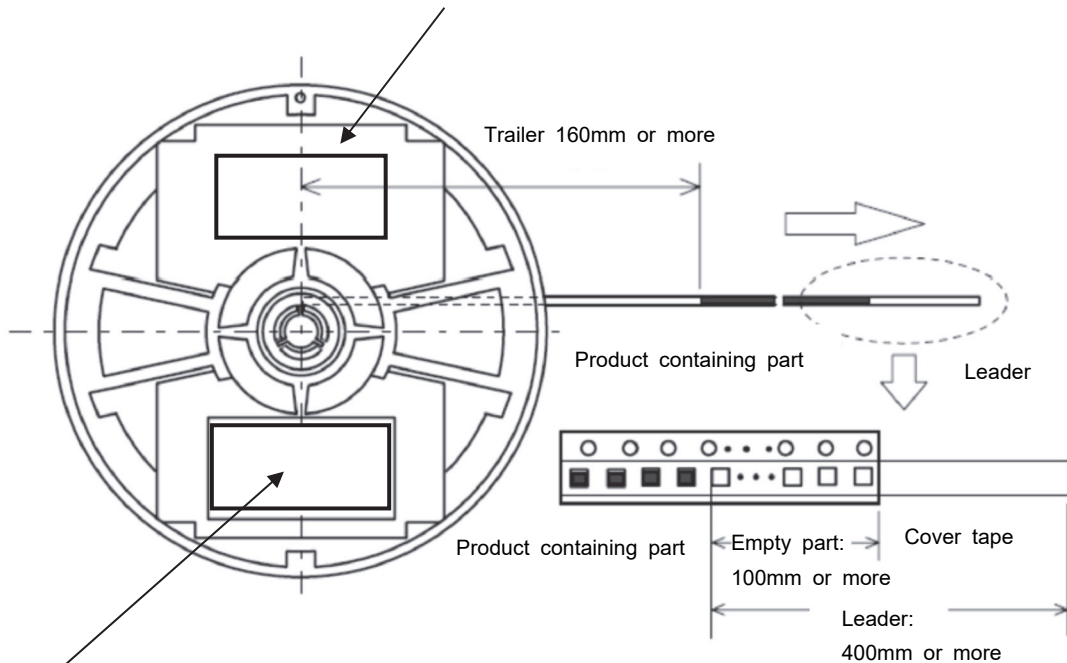

Reel label B (example)



4-2-4 Other notes

Continuously missing device shall not exceed 2 pcs.
Peeling strength of the cover tape: 0.1 to 0.7N.

4-3 Outer packing specifications

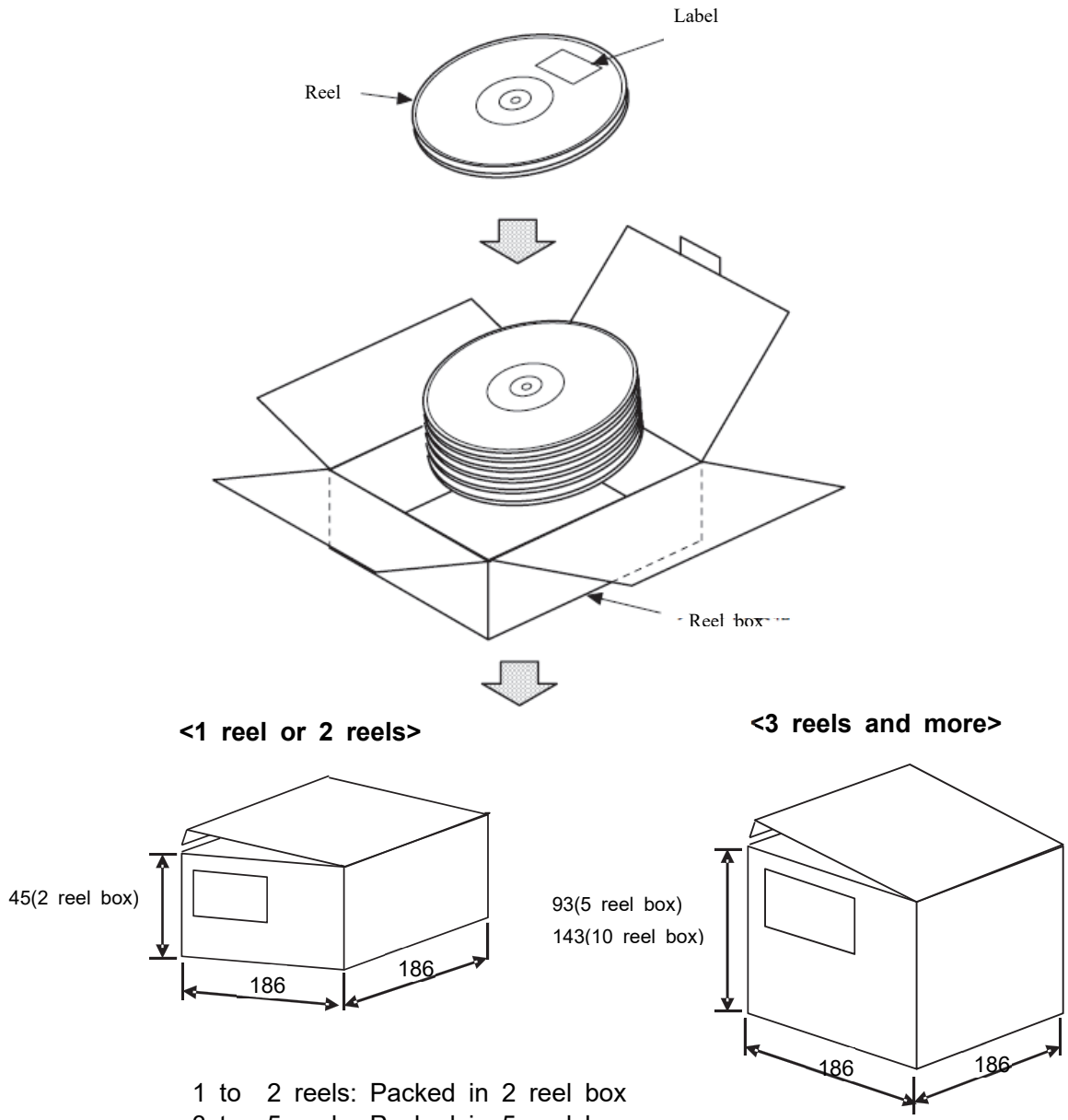

1 to 2 reels: Packed in 2 reel box
3 to 5 reels: Packed in 5 reel box
6 to 10 reels: Packed in 10 reel box

*When the box is not filled with reels, antistatic buffer material will be used to avoid product from moving inside box.

*Unit: mm, Tolerance: +/- 5mm

Material

Reel packing box: Cardboard

5. Mounting condition

5-1 Reflow condition

- Below is the maximum reflow condition for the product mounting.
- The temperature mentioned in below table and figure is package surface temperature.
- The absolute maximum package peak temperature is 260°C and time within the temperature of 260°C must not exceed 10 seconds (Requirement).

Profile	Conditions
Pre-heating Temperature Min. Temperature Max. Time from Temperature Min. to Max.	150°C 180°C 60-120s
Heating Liquidus temperature Time maintained over Liquidus temperature Peak Temperature	230°C 30s 260°C/10s max.
Cycle of reflow	3 times max.

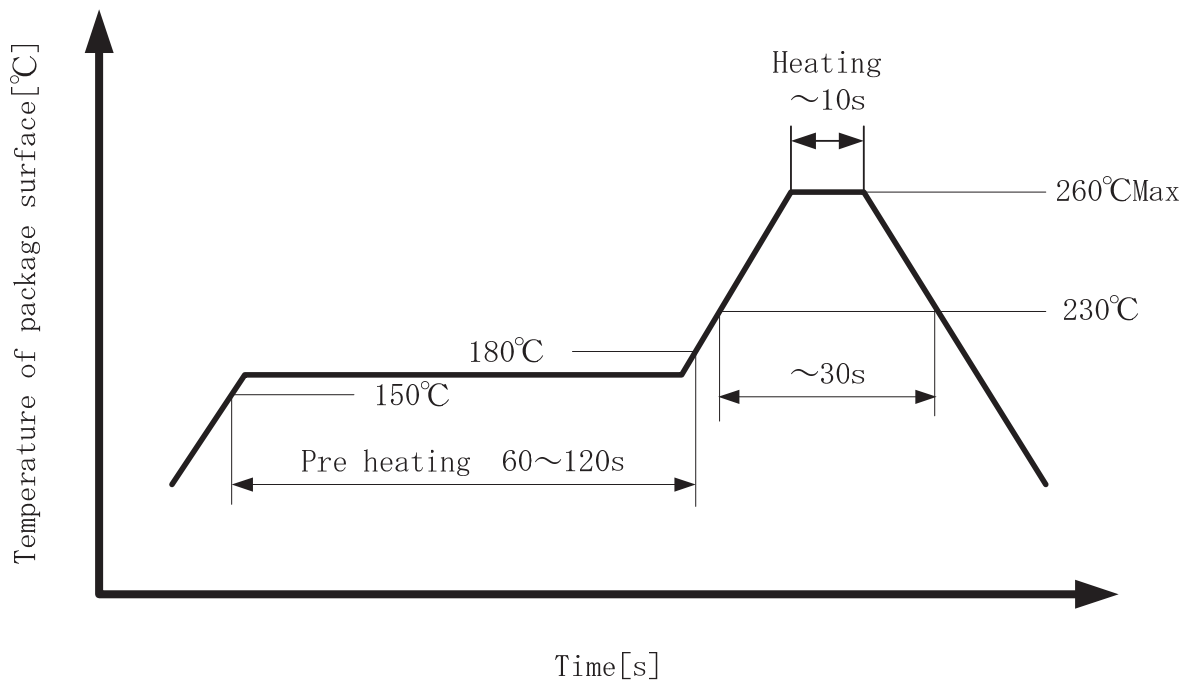

5-2 MSL

MSL(Moisture Sensitivity Level): equal to MSL1

6. Reliability test

No.	Reliability test	Test conditions	Judgment criteria	
1	High temp. storage	+125°C 500h No-load	<p>It shall be tested after being kept in a room over 2hours and Vcc= 3.0V.</p> <ul style="list-style-type: none"> • Output voltage Hi:2.7V or above Lo:0.3V or less • Using current 250 μ A or less 	
2	High temp. load	+105°C 500h Load voltage 5.5V		
3	Low temp. storage	-40°C 500h No-load		
4	High temp, high humidity load	+85°C 85%RH 500h Load voltage 5.5V		
5	Thermal shock	-55 °C /30 min \leftrightarrow +125 °C /30min (vapor phase) 500 cycle, no-load		
6	Vibration	Apply vibration [Max amplitude: 1.5mm, frequency: 10 to 55Hz, 1 cycle minute, 3 directions, 2h in each direction (total 6h)]		
7	Shock test	Unpacked condition, X, Y, Z direction, 1470m/s ² , 5 times/each		
8	Drop test	100g dummy load, Height: 150cm, on the concrete, 6 sides, 10 times/each		
9	Solder heat resistance	Pretreatment: +85°C, 85%RH, 168h Reflow condition: Max. 260°C & 230°C, 30 sec, times of reflow: 3		
10	Electrostatic resistance	Machine Model Condition: 200pF, Resistance: 0 Ω , +/-200V		
		Human Body Model Condition: 100pF, Resistance: 1.5k Ω , +/-2kV		
11	Solder ability	Solder temp.: +230°C, Time: 3 sec immersion		90% and more terminal surface covered with solder
12	Electrode sticking tendency	5N(510gf), 4 directions, 10 sec		No external abnormality found.
13	Bending cycle	Glass epoxy PCB, t=1.6, Speed: 5mm/min, 90mm span, bending range \pm 1mm, 1500 cycle		No terminal fracture, loosening found.
14	Bending limit	Glass epoxy PCB, t=1.6, 90mm span, bending range \pm 7mm.		

7. Caution

7-1 Limitation of applications

Please avoid using this product for the applications listed below which require especially high reliability in order to prevent defects that might directly cause damage to the third party's life, body, or property.

When this product is used for the applications listed below, we shall not be liable for any claims on the product.

- ① Aircraft equipment
- ② Aerospace equipment
- ③ Undersea equipment
- ④ Generating plant equipment
- ⑤ Medical equipment
- ⑥ Transportation equipment (vehicles, trains, ships, etc.)
- ⑦ Traffic signal equipment
- ⑧ Disaster prevention/ crime prevention equipment
- ⑨ Data processing equipment
- ⑩ Application of similar complexity and/or reliability requirements to the applications listed above.

7-2 Fail-safe

Be sure to provide appropriate fail-safe function on your product to prevent a second damage that may be caused by the abnormal function or the failure of our product.

8. Caution for use

8-1 Handling

- This product may be degraded by electrostatic discharge. It is necessary to take anti-static precautions when handling.

8-2 Design

- Please thoughtfully evaluate this product for the magneto-variation of the magnet used along with this product, otherwise this product may result in the miss-operation or the non-operation.
- Sensor miss-operation or non-operation may occur due to the influence of the magnetic noise from surrounding devices such as motor. Please make sure there is no influence of the magnetic noise in designing process.
- Please be careful about a magnetic body (Iron, Nickel, etc.) and a magnetic noise immunity that may affect the magnetism of a magnet.
- Please do not supply inverse voltage or excess voltage to this product. If applied, this product may be damaged and electrically destroyed.
- Please design your product not to be affected by stress of the resin due to heat shrink.

- Sensor output (Vout) is not stable at power on to the sensor. After power on, it needs about 4 times of Tc showed on item 3-4 to make it stable.
- Please avoid plugging/unplugging of connector cable while the power is on

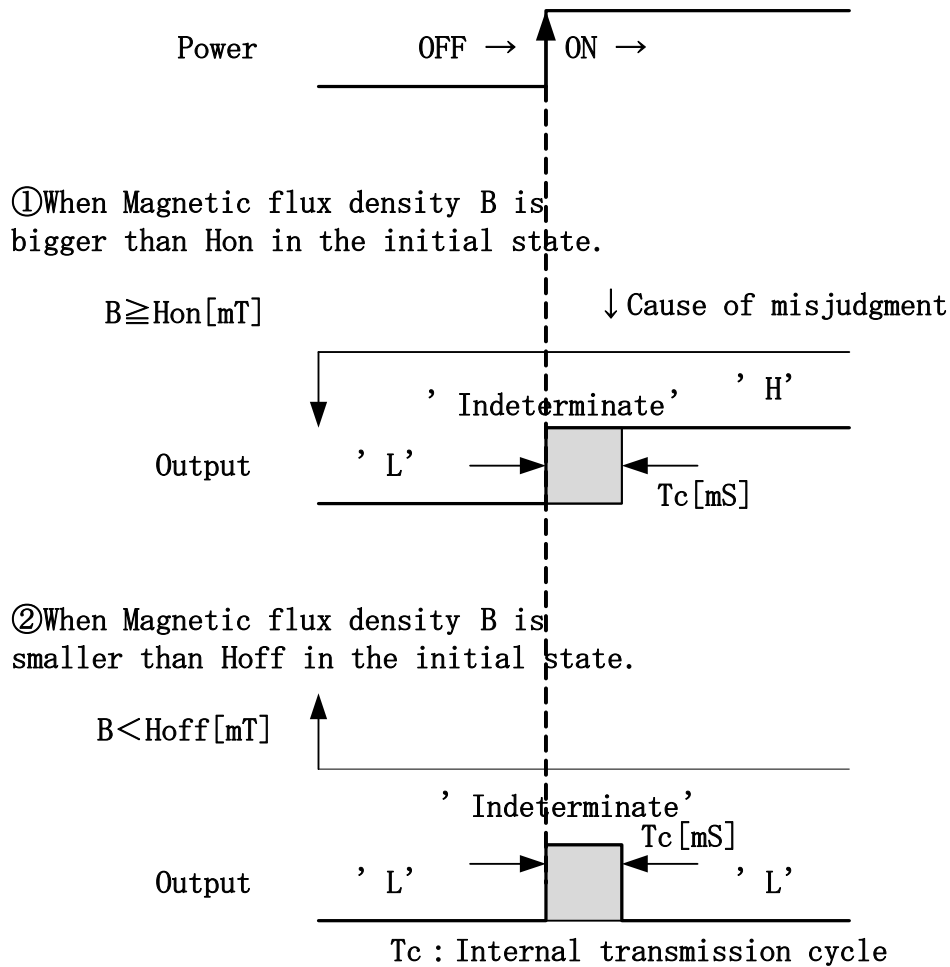

- It is effective to place a bypass capacitor near AMR sensor for power supply noise suppression.

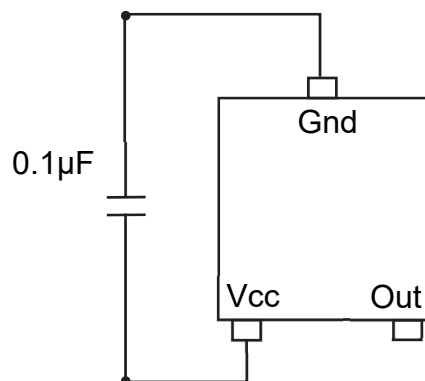

- * 0.1 μF is the recommended value and does not guarantee operation. Please select the suitable capacity depending on the usage environment. In addition, when the sensor is used under high noise level, Zener diode is recommended in parallel with a bypass capacitor.

8-3 Storage condition

- Recommended storage conditions are listed below.

Temperature: +5 to +30°C

Humidity : 70%(RH)% and lower

*Desiccator storage or storage in N₂ atmosphere is recommended.

- Allowable storage time of the product is one year from the date of delivery. Please take account of the storage conditions listed above. Please also use the product as soon as possible after opening the product packing to avoid the deterioration of solder ability.
- Please avoid the water, chemical solvent, or oil.
- Please avoid the corrosive gas (Cl₂ H₂S, NH₃ NO₂, NO₃ etc.)
- Please avoid the strong vibration or shock.

8-4 Mounting

- Please mount this product under standard reflow condition. Otherwise this product may be damaged.
- Hand soldering is not allowed for this product.
- Please do not apply excessive load to the terminals. Also, please do not bend the terminals.
- Please do not apply excessive bending stress to the product by bending the PCB or by similar handling as it may change the sensor sensitivity.
- Please make sure the mounting state of the sensor after mounting it. Depend on your application, mounting error may cause the sensor miss operation.

9. Note

- Make sure that your product has been evaluated in view of your specifications with our product being mounted to your product.
- Not to use our product deviating from the agreed specification.