



UFM-01

Ultrasonic Flow Sensing Module

UFM-01 Datasheet

Revision: 10

Release Date: 2025-06-11

Document Status: Product Preview

The UFM-01 is a complete unit including the sensor electronics, spool piece, connectors with standard ½” thread, and a cable connector supporting single-wire and UART interfaces.

The module is based on SciSense contactless ultrasonic flow sensor technology, which does away with the rotors and other mechanical parts in traditional Hall sensor-based flow sensors. By contrast, the ultrasonic UFM-01 contains no moving parts and offers an unlimited lifetime when operated according to datasheet specifications.

The UFM-01 is suitable for use with food-grade material, and can directly measure drinking water flows. Accurate to at least ±5 % at flow rates above 60 l/hr, the UFM-01 enables precise control of liquid flow and - via a built-in temperature sensor - liquid temperature in the control systems of products such as boilers, smart taps, beverage brewing machines and more.

Key Features & Benefits

- **Long-time reliability**
Solve the pain point, no movable parts, no risk of getting stuck
- **High accuracy**
Up to 5% accuracy at wide range (can be even better with customization)
- **Wide sensing range**
0 to 3125 l/h
- **Low power**
2mA average current with single 5 V power supply
- **Standard interface**
UART, 1-wire communication supported and industrial standard mechanical interface
- **Cost effective**
Simplified system design and automatic production to optimize the overall cost
- **Food grade material**
Can be used for drinking water directly

Applications

- **Boilers**
- **Water purifiers**
- **Coffee Machines**
- **Smart toilets**

Table of Contents

Key Features & Benefits	2
Applications	2
Table of Contents	3
1 Block diagram	4
2 Absolute maximum ratings	4
3 Electrical characteristics	5
4 Sensor characteristics	5
5 Interface Description	6
6 Mechanical Outline	7
7 Application Information	7
7.1 UART.....	7
7.2 1-wire Connection	8
8 UART Protocol	8
8.1 Host Protocol.....	8
8.2 Command Definition.....	9
8.3 Host / Device protocol Examples	10
8.4 Data Output Format	11
8.5 Answer Set Frequency & Start Flow..	14
8.6 Answer Software Version	14
9 1-wire Protocol	15
9.1 Protocol Description.....	15
9.1.1 BUS Initialization (1WRST)	15
9.1.2 Master Write Operation.....	15
9.1.3 Master Read operation.....	16
9.2 1-wire Command.....	17
9.3 1-wire registers	17
9.4 CRC-8 calculation	18
10 Ordering information	19
11 RoHS Compliance & SciSense Green Statement	20
12 Copyrights & Disclaimer	20
13 Document status	21
14 Revision information	21

1 Block diagram

The internal block diagram of UFM-01 is shown in [Figure 1](#).

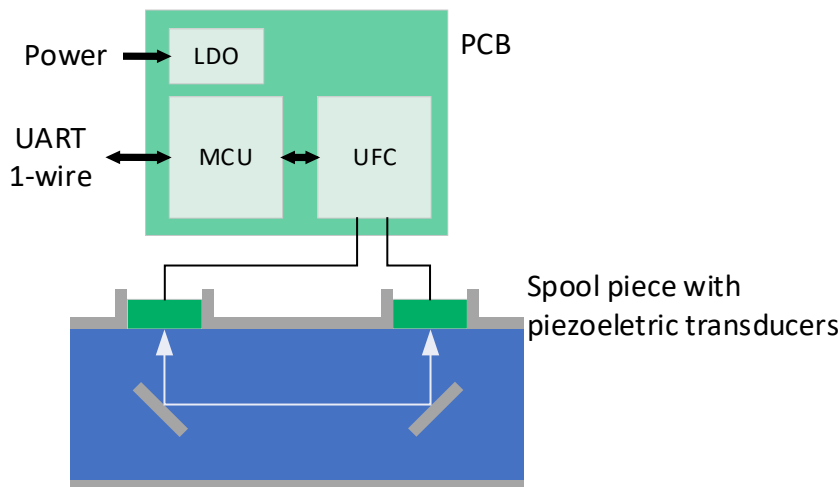

Figure 1: Functional blocks

2 Absolute maximum ratings

Stresses beyond those listed in this section may cause permanent damage to the device. These are - each at a time - stress ratings only. Functional operation of the device at these or any other conditions beyond those indicated under [Electrical characteristics](#) is not implied. Exposure to absolute maximum rating conditions for extended periods may affect device reliability. The UFM-01 should be protected against constant exposure to sunlight and humidity. It's also not designed for application submerge into water.

Table 1: UFM-01 absolute maximum ratings

Symbol	Parameter	Min	Max	Units	Comments
Electrical Parameters					
V _{DD}	Supply voltage	-0.30	6.0	V	
V _{IO}	IO voltage level	-0.30	5.5	V	UART_RX, UART_TX, 1-Wire
Electrostatic Discharge					
ESD _{HBM}	Contact discharge, all pins	±4000		V	IEC 61000-4-2
Water Pressure					
p _{Watr}	Maximum water pressure	4.0		MPa	
Operating and Storage Conditions					
T _{STRG}	Storage temperature	-25	100	°C	

T_A	Operating ambient temperature	-25	85	°C	
T_{Water}	Operating water temperature	0	60	°C	Not frozen
H_A	Operating ambient relative humidity	0	100	%RH	
p_{Water}	Operating water pressure		1.75	MPa	

The UFM-01 should be protected against constant exposure to sunlight and humidity and it's designed for application submerge into water.

3 Electrical characteristics

All limits are guaranteed. The parameters with min and max values are guaranteed with production tests or SQC (Statistical Quality Control) methods. All values refer to $T_A = 25\text{ °C}$ and at 5V supply voltage, unless otherwise specified.

Table 2: Electrical characteristics

Symbol	Parameter	Conditions	Min	Typ	Max	Unit
V_{DD}	Supply voltage		4.5	5.0	5.5	V
I_{DDavg}	Average Supply current	25 °C 85 °C		2	t.b.d.	mA
I_{DDpk}	Peak Supply current	25 °C 85 °C		2.6	3	mA
V_{IH}	High-level input voltage		$0.7 \times V_{DD}$		$V_{DD} + 0.3$	V
V_{IL}	Low-level input voltage		-0.5		0.7	V

4 Sensor characteristics

Table 3: Electrical characteristics

Symbol	Parameter	Conditions	Min	Typ	Max	Unit
F_{range}	Flow sensing range		10		3125 ¹	l/h
F_{acc}	Flow sensing accuracy of reading	10 to 60 l/h			±10	%
		60 to 2000 l/h		±3	±5	

¹ Above this maximum flow an error flag will be set and the precision is no longer guaranteed.

T_{range}	Water temperature measurement range		1		60	°C
T_{acc}	Water temperature accuracy			± 1		°C
f_{data}	Data output rate			1	4	Hz

5 Interface Description

Table 4: Electrical characteristics

Pin Number	Pin Name	Description	
1	1-Wire	1-Wire output	Connector: CWB (https://www.cwb.com.cn/ TJC2004-5Y Counterparts (e.g. TJC2004-5A) Counter parts: e.g. Molex 55932-0530 and 55935-0510
2	VCC	Power supply	
3	GND	Ground	
4	UART_RX	UART RX input	
5	UART_TX	UART TX output	

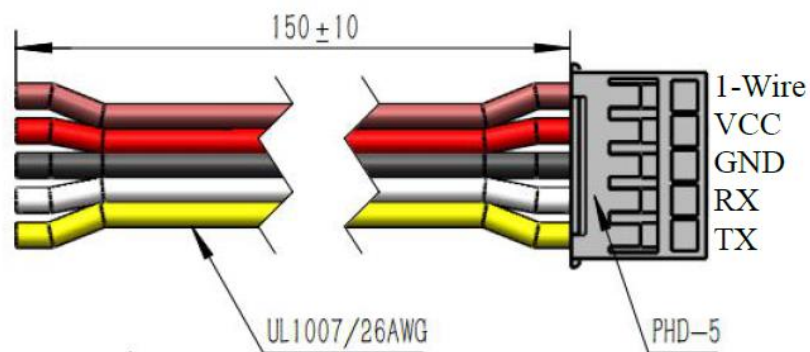

6 Mechanical Outline

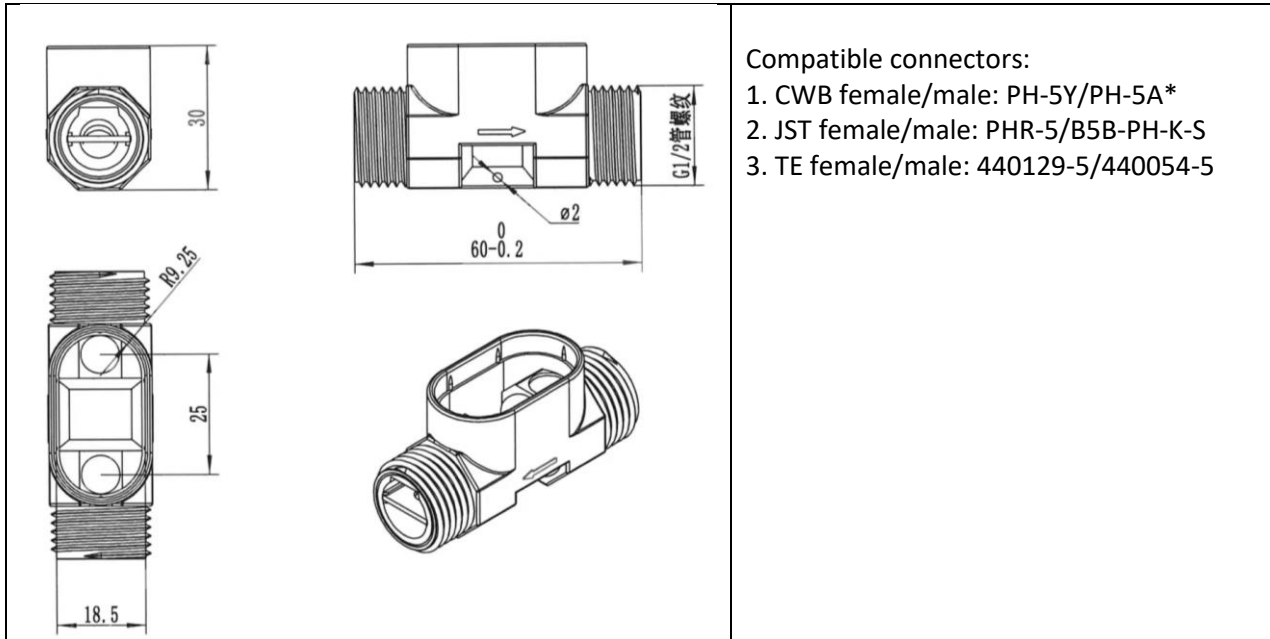

Figure 2: mechanical drawings

7 Application Information

7.1 UART

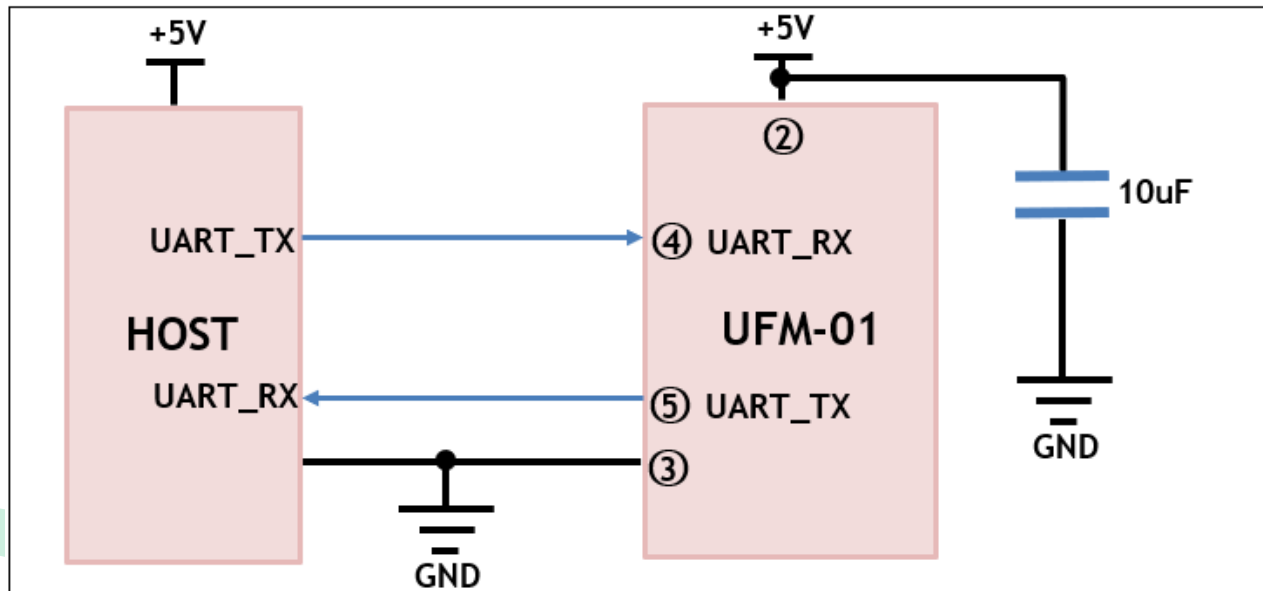

Figure 3: UFM-01 typical Application with UART connection

7.2 1-wire Connection

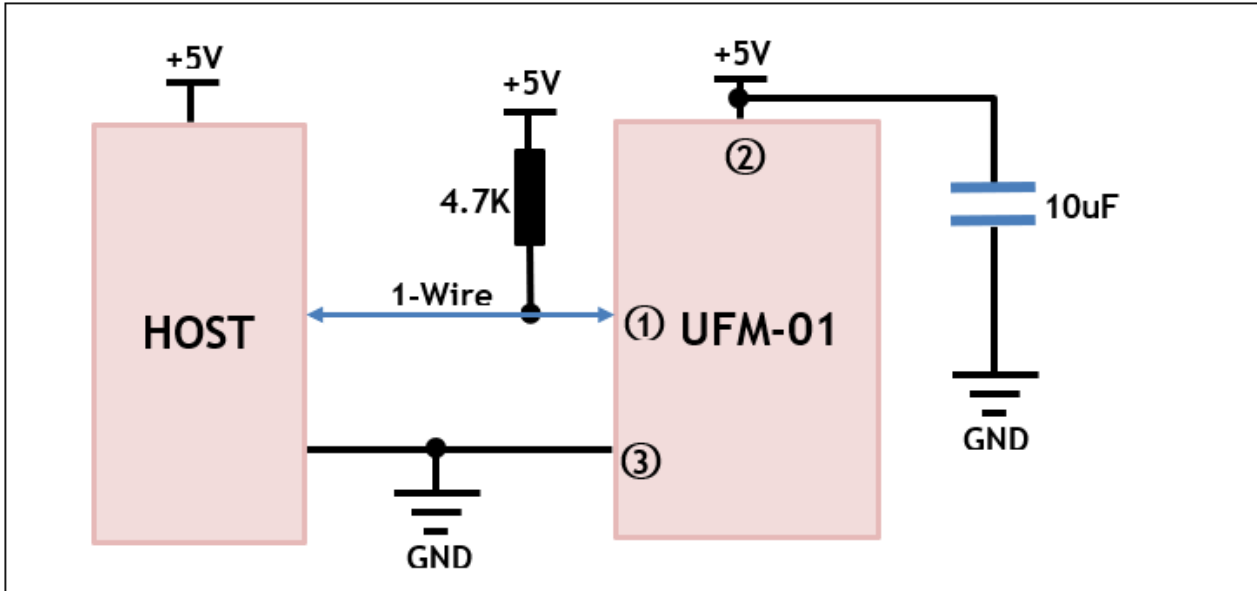

Figure 4: UFM-01 typical Application with 1-wire connection

8 UART Protocol

The UART protocol is based on

- Baud rate: 2400 bit/s
- Data bits: 8
- Parity: Even
- Stop bit: 1

8.1 Host Protocol

Table 5: Host protocol

Prefix Byte 1	Prefix Byte 2	Start Byte 1	Command Byte	Command para Byte	Checksum Byte	Stop Byte
0xFE	0xFE	0x11	CMD	DATA	CS	0x16

CS =(Command Byte +Command para byte n) & 0xFF

8.2 Command Definition

Table 6: Command definition

CMD	DATA1	Note
0x5A	0xFD	Clear accumulated flow
0x5C	0x00- active 0x01- passive	Change passive/active mode: Passive mode: device only send data when the host send a read command, data format according to the Table 8: Data output(Passive Mode, Data report when read all data including ID) and Table 9: Data output(Passive Mode, Data report when read data without ID). Active mode: device send data automatically every second, data format according to the Table 7. Default: Active mode
0x5B	0xCB 0x0F	Read sensor data: 0xCB: Read all data including ID. 0x0F: Read data without ID. Data format defined in Table 8 and Table 9.
0x5D	0xCB	Reset the device
0x5E ²	0x62	Read out Software Version
0x60 ²	0xA0 0x00 0xA1 0x00 0x10 0x00 0x10 0x00 0x10 0xA2 + frequency 0xA3 + start flow 0xA4 0x00 0x00 0x00	Reserved data Reserved data Reserved data Frequency Flag 0xA2 Frequency: 0x01 Hz, 0x02 = 2 Hz, 0x04 = 4Hz, 0x08 = 8 Hz ³ Start flow: flow in 0.1l/h lowest byte e.g. 0x15 for 1.5l/h middle byte 0x00 highest byte 0x00 Reserved

² only available at Software Version >= 24210810 and Production Date >= 2024.08.05

³ 8 Hz not supported by UART

8.3 Host / Device protocol Examples

- a) Clear accumulated flow
 Host 0xFE 0xFE 0x11 0x5A 0xFD 0x57 0x16
 Device 0xE5
- b) Change passive/active mode
 Change to passive mode:
 Host 0xFE 0xFE 0x11 0x5C 0x01 0x5D 0x16
 Device 0xE5

 Change to active mode:
 Host 0xFE 0xFE 0x11 0x5C 0x00 0x5C 0x16
 Device 0xE5
- c) Read sensor data(WithOut ID):
 Host 0xFE 0xFE 0x11 0x5B 0x0F 0x6A 0x16
 Device Data out defined in 8.4. Data output format
- d) Read sensor data(With ID):
 Host 0xFE 0xFE 0x11 0x5B 0xCB 0x26 0x16
 Device Data out defined in 8.4. Data output format
- e) Reset the module:
 Host 0xFE 0xFE 0x11 0x5D 0xCB 0x28 0x16
 Device 0xE5
- f)² Set frequency 4Hz & start flow 1.5l/h:
 Host 0xFE 0xFE 0x11 0x60 0xA0 0x00 0xA1 0x00 0x10 0x00 0x10 0x00 0x10 0xA2 0x04
 0xA3 0x15 0x00 0x00 0xA4 0x00 0x00 0x00 0xD3 0x16
 Device Data out defined in 8.5.
- g)² Readout Software Version:
 Host 0xFE 0xFE 0x11 0x5E 0x62 0xC0 0x16
 Device Data out defined in 8.6

8.4 Data Output Format

Table 7: Data output(Active Mode)

0	1	2	3	4	5	6	7
Start Byte1	Start Byte2	Device ID, fox example 2307140001 Data: 230714 SerialNum:0001					Reserved
0x3C	0x32	0x01	0x00	0x14	0x07	0x23	0x01

8	9	10	11	12	13	14	15
Acc Flow Flag	If Flag is 0x0A, then Acc Flow is 331023456.789l LSB:0.001L If Flag is 0x1A, then Acc Flow is 331023456.789m3 LSB:0.001m3						Instant Flow Flag
0x0A 0x1A	0x89	0x67	0x45	0x23	0x10	0x33	0x0B

16	17	18	19	20	21	22	23
Instant Flow is -234567.89 l/h, LSB:0.01l/h Byte 20:0x80,Negative Value					Reserved		
0x89	0x67	0x45	0x23	0x80	0x0C		

24	25	26	27	28	29	30	31
Temp Flag	Measured water temperature in degree, for example 56.34 °C			ST1	ST2	Checksum	Stop Byte
0x0D	0x34	0x56	0x00			CS =(Byte 0 + Byte 1 + ... +ST2) & 0xFF	0x16

Table 8: Data output(Passive Mode, Data report when read all data including ID)

0	1	2	3	4	5	6	7
Start Byte1	Start Byte2	Device ID, fox example 2307140001 Data: 230714 SerialNum:0001					Reserved
0x3C	0x96	0x01	0x00	0x14	0x07	0x23	

8	9	10	11	12	13	14	15
Acc Flow Flag	If Flag is 0x0A, then Acc Flow is 331023456.789l LSB:0.001L If Flag is 0x1A, then Acc Flow is 331023456.789m3 LSB:0.001m3					Reserved	
0x0A/0x1A	0x89	0x67	0x45	0x23	0x10	0x33	

16	17	18	19	20	21	22	23
Reserved						Instant Flow Flag	
						0x0B	0x89

24	25	26	27	28	29	30	31
-234567.89 l/h,LSB:0.01l/h Byte 27: 0x80, Negative Value				Reserved			Temp Flag
0x67	0x45	0x23	0x80				0x0D

32	33	34	35	36	37	38
Measured water temperature in degree, for example 56.34 °C			ST1	ST2	Checksum	Stop Byte
0x34	0x56	0x00			CS =(Byte 0 + Byte 1 + ... + ST2) & 0xFF	0x16

Table 9: Data output(Passive Mode, Data report when read data without ID)

0	1	2	3	4	5	6	7
Start Byte1	Start Byte2	Acc Flow Flag	If Flag is 0x0A, the Acc Flow is 331023456.789l LSB:0.001L If Flag is 0x1A, the Acc Flow is 331023456.789m3 LSB:0.001m3				
0x3C	0x64	0x0A/0x1A	0x89	0x67	0x45	0x23	0x10

8	9	10	11	12	13	14	15
	Instant Flow Flag	-234567.89 l/h, LSB:0.01l/h Byte 14: 0x80, Negative Value					Temp Flag
0x33	0x0B	0x89	0x67	0x45	0x23	0x80	0x0D

16	17	18	19	20	21	22
Measured water temperature in degree, for example 56.34 °C			ST1	ST2	Checksum	Stop Byte
0x34	0x56	0x00			CS =(Byte 0 + Byte 1 + ... + ST2) & 0xFF	0x16

Status bytes ST1 & ST2 are used for error code:

ST2	Bit7	Bit6	Bit5	Bit4	Bit3	Bit2	Bit1	Bit0
			UFC chip error		Flow direction wrong	Flow rate out of range		

ST1	Bit7	Bit6	Bit5	Bit4	Bit3	Bit2	Bit1	Bit0
			Empty tube			-	-	

UFC chip error:

Flow direction wrong:

Empty tube:

Flow rate out of range:

UFC not detected or abnormal.

Negative flow detected.

No water detected in the tube.

Big flow rate out of range continuously detected for 5s.

8.5 Answer Set Frequency & Start Flow

Table 10: Answer

0	1	2	3	4	5	6	7	8	9
ACK	Reserved								
0xE5	0xA0	/	0xA1	/	/	/	/	/	/

10	11	12	13	14	15
Frequency Flag	Frequency is 4 Hz	Startup Flow Rate Flag	The Startup Flow Rate is 1.5l/h, LSB:0.1l		
0xA2	0x04	0xA3	0x15	0x00	0x00

16	17	18	19	20	21
Reserved	Reserved			Checksum Byte	Stop Byte
0xA4	/	/	/	CS =(Byte 1) +... + (Byte 19)) & 0xFF	0x16

8.6 Answer Software Version

Table 11: Answer

0	1	2	3	4	5	6
ACK	Software Version: 23380315				Checksum Byte	Stop Byte
0xE5	0x15	0x03	0x38	0x23	CS =(Byte 1 + ... + Byte 4) & 0xFF	0x16

9 1-wire Protocol

9.1 Protocol Description

The read and write operation of 1-wire protocol is low bit first and high bit last. The 1-wire interface of UFM-01 receives the reading time sequence and sends out measurement data. If the data is not ready, all the data will be zero. UFM-1 is a slave, which transmits data at a rate of 16.3k bit/s.

The sequence parameters in the figures in this section are from the general standard, and the brackets are the parameters implemented by the slave. In addition to standard function mode (NM), UFM-1 has added a simplified mode (SM) to reduce data flow.

As 1-wire interface is simulated via MCU's GPIO, it is not fully compatible with the hardware interface and some parameters are limited, pls refer to the following description for details.

9.1.1 BUS Initialization (1WRST)

The slave will pull the BUS down 60-240 us within 15-60 us after receiving the effective jump. During this period, the host will sample the bus to determine whether the slave is connected to the current BUS.

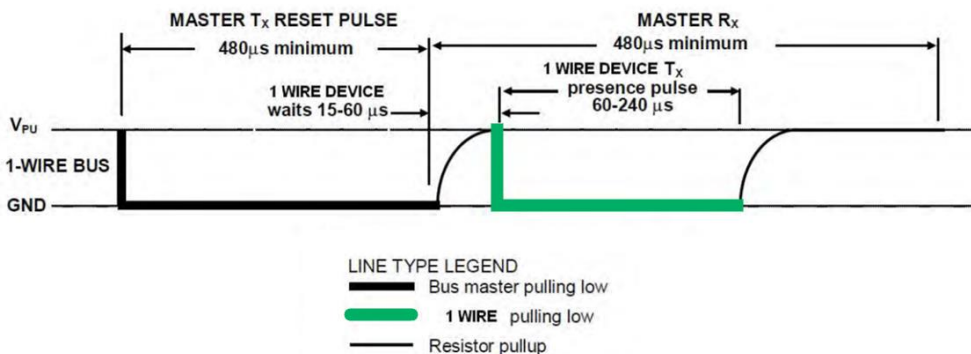

Figure 5: 1-wire bus reset timing

9.1.2 Master Write Operation

It needs at least 60 us for the master to write one bit to the bus, and there is more than 1 us interval for continuous write operations.

The operation steps of the master when writing data are as follows:

- 1) The master pulls down the bus by 1 us.
- 2) The master releases the bus within 15 us (routine is 3 us), and then puts the data immediately.
- 3) The master waits (routine is 50 us) for the end of this receiving cycle of 60 us, and then releases the bus.

4) If the data is not sent completely, wait for 1 us, repeat the above steps, and prepare to send the next bit.

The operation steps of the slave when writing data are as follows:

- 1) When there are 1-15 us low pulses on the slave detection bus, it is ready to receive data.
- 2) The slave reads the bus data in a time window of 15-60 us (20 us is recommended).

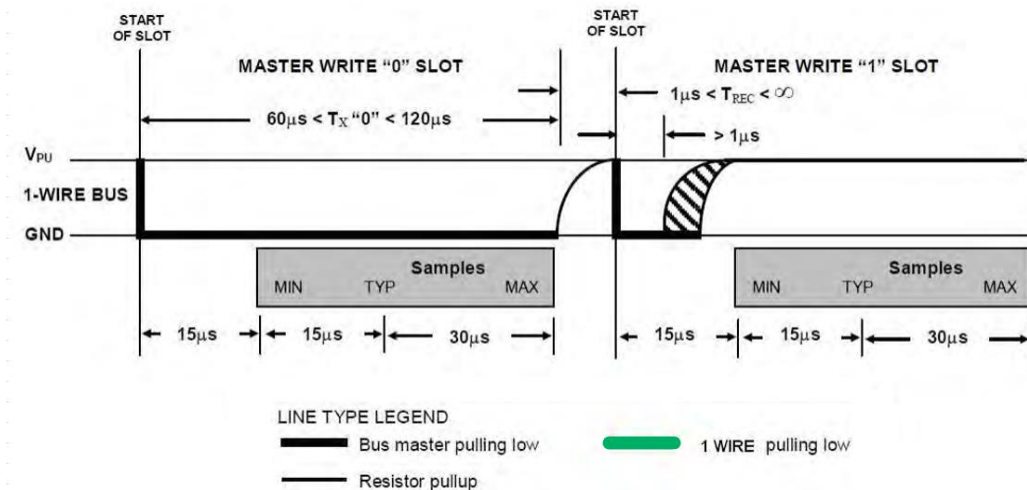

Figure 6: 1-wire write timing

9.1.3 Master Read operation

The master needs at least 60 us to read one bit from the bus, and the interval between two consecutive read operations is more than 1 us.

When reading data, the master operation steps are as follows:

- 1) The master pulls down the bus by 1-15 us (routine is 4 us) and then releases it.
- 2) The host reads the bus value within 15 us, with a routine of 11 us.
- 3) The master waits (routine 40 us) for the end of this receiving cycle of 60 us, and then releases the bus.
- 4) If the data is not received completely, wait for 1 us or more (routine is 1 us), repeat the previous steps, and prepare to receive the next bit.

When reading data, the slave operation steps are as follows:

- 1) The slave detects the bus, data is immediately inserted when there are 1-15 us low pulses or at the falling edge.

Note: If the low pulse of the host is as low as 1 us, the slave may not be able to detect the accurate pulse width. A compromise method can be considered: after the slave detects the falling edge, it detects the high level arrival time t through interrupts or scans greater than 1 us

and less than 10 us. If t is less than 10 us, the slave will input data; If t is greater than 10 us, continue to detect and determine whether it is a 1WRST signal.

- 2) Hold the data to 60 us and then release the bus.
- 3) If the data is not sent completely, repeat the above steps to prepare to send the next bit.

9.2 1-wire Command

The command format is: command [parameters] [checksum], and the content of [] can be omitted, and the checksum is the 8-bit cumulative value of the parameter.

Table 12: 1-wire Command format

Command	Function
0x5a	Clear accumulated flow
0x5b, REG, data1,data2 ...	Continuously read data from address register (REG), with REG and read range from 0x30 to 0x3b
0x5d	Reset module

Notes:

1. [para] is the data read, with low bytes leading and can be omitted. After omission, the function of the command is the same as 0xaa.
2. The NM mode can be switched directly by command. When switching between SM mode and NM mode, or between SM modes, initialization (1WRST) must be executed first.
3. When already in SM mode, there is no need to issue a command to read data. Instead, initiate a read operation and return the last requested type data from the slave.

9.3 1-wire registers

Address	Symbol
0x30	InFL_L
0x31	InFL_M
0x32	InFL_H
0x33	InFL_CRC8
0x34	T_L
0x35	T_M
0x36	T_H
0x37	T_CRC8
0x38	CuFL_L
0x39	CuFL_M
0x3a	CuFL_H
0x3b	CuFL_CRC8

Example 1: 0x30 to 0x32 are sequentially 0x40, 0x0d, and 0x03, indicating an instantaneous flow of $200000 \times 0.01=2000$ l/h.

Example 2: 0x34 to 0x36 are sequentially 0x70, 0x17, and 0x00, indicating a temperature of $6000 \times 0.01 = 60 \text{ }^\circ\text{C}$.

Example 3: 0x38 to 0x3a are sequentially 0xff, 0xff, and 0xff, indicating a cumulative flow of $16777215 \times 1677721.5 \text{ l}$ (1677.7 m^3). 1-wire parameters

9.4 CRC-8 calculation

CRC-8 calculation of array 'val' with a length of 'length'

```
uint8_t crc8( uint8_t *val, uint8_t length )
{
    uint8_t CRC=0xFF;
    uint8_t i,t;
    for(i=0;i<length;i++)
    {
        CRC^=val[i];
        for(t=8;t>0;--t)
        {
            if(CRC&0x80) { CRC=(CRC<<1)^0x31u;}
            Else { CRC=(CRC<<1); }
        }
    }
    return CRC;
}
```

10 Ordering information

Table 13: Ordering information

Ordering Code	Material ID	Package	Description	Delivery Quantity
UFM-01	501911001	-	Ultrasonic flow module DN10	50 pc

11 RoHS Compliance & SciSense Green Statement

RoHS: The term RoHS compliant means that Sciosense B.V. products fully comply with current RoHS directives. Our semiconductor products do not contain any chemicals for all 6 substance categories, including the requirement that lead does not exceed 0.1% by weight in homogeneous materials. Where designed to be soldered at high temperatures, RoHS compliant products are suitable for use in specified lead-free processes.

SciSense Green (RoHS compliant and no Sb/Br): SciSense Green defines that in addition to RoHS compliance, our products are free of Bromine (Br) and Antimony (Sb) based flame retardants (Br or Sb do not exceed 0.1% by weight in homogeneous material).

Important Information: The information provided in this statement represents Sciosense B.V. knowledge and belief as of the date that it is provided. Sciosense B.V. bases its knowledge and belief on information provided by third parties, and makes no representation or warranty as to the accuracy of such information. Efforts are underway to better integrate information from third parties. Sciosense B.V. has taken and continues to take reasonable steps to provide representative and accurate information but may not have conducted destructive testing or chemical analysis on incoming materials and chemicals. Sciosense B.V. and Sciosense B.V. suppliers consider certain information to be proprietary, and thus CAS numbers and other limited information may not be available for release.

12 Copyrights & Disclaimer

Copyright Sciosense B.V High Tech Campus 10, 5656 AE Eindhoven, The Netherlands. Trademarks Registered. All rights reserved. The material herein may not be reproduced, adapted, merged, translated, stored, or used without the prior written consent of the copyright owner.

Devices sold by Sciosense B.V. are covered by the warranty and patent indemnification provisions appearing in its General Terms of Trade. Sciosense B.V. makes no warranty, express, statutory, implied, or by description regarding the information set forth herein. Sciosense B.V. reserves the right to change specifications and prices at any time and without notice. Therefore, prior to designing this product into a system, it is necessary to check with Sciosense B.V. for current information. This product is intended for use in commercial applications. Applications requiring extended temperature range, unusual environmental requirements, or high reliability applications, such as military, medical life-support or life-sustaining equipment are specifically not recommended without additional processing by Sciosense B.V. for each application. This product is provided by Sciosense B.V. "AS IS" and any express or implied warranties, including, but not limited to the implied warranties of merchantability and fitness for a particular purpose are disclaimed.

This product is not intended for use as safety device and/or in applications where failure of the product could result in personal injury. Sciosense B.V. shall not be liable to recipient or any third party for any damages, including but not limited to personal injury, property damage, loss of profits, loss of use, interruption of business or indirect, special, incidental or consequential damages, of any kind, in connection with or arising out of the furnishing, performance or use of the technical data herein. No obligation or liability to recipient or any third party shall arise or flow out of Sciosense B.V. rendering of technical or other services.

13 Document status

Table 14: Document status

Document Status	Product Status	Definition
Preliminary Datasheet	Pre-Production	Information in this datasheet is based on products in the design, validation or qualification phase of development. The performance and parameters shown in this document are preliminary without any warranty and are subject to change without notice.
Datasheet	Production	Information in this datasheet is based on products in ramp-up to full production or full production which conform to specifications in accordance with the terms of SciSense B.V. standard warranty as given in the General Terms of Trade.

14 Revision information

Table 15: Revision history

Revision	Date	Comment	Page
1	2023-03-21	Preliminary Version – Product Launch	All
2	2023-06-12	Update UART protocol, Update power consumption Add 1-wire protocol	8, 9, 2, 5 12ff
3	2023-11-04	Maximum flow extended, note added Sample rate added New connectors, compatible with JST or TE Chapter 8.2 & 8.3 references corrected, Set Frequency and start flow rate added Chapter 8.5 added	2, 5 5 6 8ff
4 & 5	2024-11	Internal revisions only, not released	
6	2024-11-25	Sample rate and start flow setting added	9
7	2024-03-07	Command Software Version Read added Footnote added for Add note for Valid Features Section 8.6 Answer Software Version added	9 9 13
8	2024-03-10	Formatting / Dates corrected	
9	2024-05-22	Use case protection definition added	4
10	2024-06-10	Corrected Content of Table 7-9, updated Sec 8.3 and 8.6	10-14

Notes:

1. Page and figure numbers for the previous version may differ from page and figure numbers in the current revision.
2. Correction of typographical errors is not explicitly mentioned.

Address: Sciosense B.V.
High Tech Campus 10
5656 AE Eindhoven
The Netherlands

Contact: www.sciosense.com
info@sciosense.com