

# Silicon Carbide (SiC) MOSFET - EliteSiC, 16 mohm, 650 V, M3S, T2PAK

## NTT2016N065M3S

### Features

- Typical  $R_{DS(on)} = 16 \text{ m}\Omega @ V_{GS} = 18 \text{ V}$
- Ultra Low Gate Charge ( $Q_{G(tot)} = 100 \text{ nC}$ )
- High Speed Switching with Low Capacitance ( $C_{oss} = 208 \text{ pF}$ )
- 100% Avalanche Tested
- This Device is Halide Free and RoHS Compliant with Exemption 7a, Pb-Free 2LI (on second level interconnection)

### Applications

- SMPS, Solar Inverters, UPS, Energy Storages, EV Charging Infrastructure

### MAXIMUM RATINGS ( $T_J = 25 \text{ }^\circ\text{C}$ unless otherwise noted)

Parameter	Symbol	Value	Unit
Drain-to-Source Voltage	$V_{DSS}$	650	V
Gate-to-Source Voltage	$V_{GS}$	-8/+22	V
Continuous Drain Current	$T_C = 25 \text{ }^\circ\text{C}$	$I_D$	85 A
Power Dissipation		$P_D$	333 W
Continuous Drain Current	$T_C = 100 \text{ }^\circ\text{C}$	$I_D$	62 A
Power Dissipation		$P_D$	167 W
Pulsed Drain Current (Note 1)	$T_C = 25 \text{ }^\circ\text{C}$ $t_p = 100 \text{ }\mu\text{s}$	$I_{DM}$	178 A
Continuous Source-Drain Current (Body Diode)	$T_C = 25 \text{ }^\circ\text{C}$ $V_{GS} = -3 \text{ V}$	$I_S$	49 A
	$T_C = 100 \text{ }^\circ\text{C}$ $V_{GS} = -3 \text{ V}$		29
Pulsed Source-Drain Current (Body Diode) (Note 1)	$T_C = 25 \text{ }^\circ\text{C}$ $V_{GS} = -3 \text{ V}$ $t_p = 100 \text{ }\mu\text{s}$	$I_{SM}$	198 A
Single Pulse Avalanche Energy ( $I_{LPK} = 60 \text{ A}$ , $L = 0.1 \text{ mH}$ ) (Note 2)	$E_{AS}$	180	mJ
Operating Junction and Storage Temperature Range	$T_J, T_{stg}$	-55 to +175	$^\circ\text{C}$
Lead Temperature for Soldering Purposes (1/8" from case for 10 seconds)	$T_L$	245	$^\circ\text{C}$

Stresses exceeding those listed in the Maximum Ratings table may damage the device. If any of these limits are exceeded, device functionality should not be assumed, damage may occur and reliability may be affected.

1. Single pulse, limited by max junction temperature.
2.  $E_{AS}$  of 180 mJ is based on starting  $T_J = 25 \text{ }^\circ\text{C}$ ,  $L = 0.1 \text{ mH}$ ,  $I_{AS} = 60 \text{ A}$ ,  $V_{DD} = 100 \text{ V}$ ,  $V_{GS} = 18 \text{ V}$ .

$V_{(BR)DSS}$	$R_{DS(ON)}$ TYP	$I_D$ MAX
650 V	16 m $\Omega$ @ $V_{GS} = 18 \text{ V}$	85 A

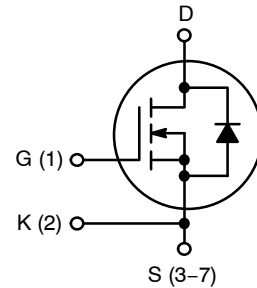

N-CHANNEL MOSFET

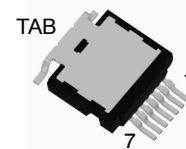

T2PAK-7  
CASE 763AC

### MARKING DIAGRAM

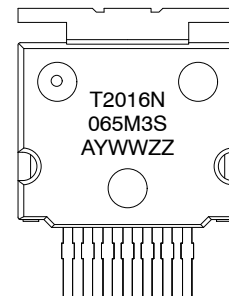

NTT2016N065M3S = Specific Device Code  
 A = Assembly Site  
 WW = Work Week Number  
 Y = Year of Production, Last Number  
 ZZ = Assembly Lot Number, Last Two Numbers

### ORDERING INFORMATION

Device	Package	Shipping <sup>†</sup>
NTT2016N065M3S	T2PAK-7L	800 / Tape & Reel

<sup>†</sup> For information on tape and reel specifications, including part orientation and tape sizes, please refer to our Tape and Reel Packaging Specification Brochure, [BRD8011/D](#).

# NTT2016N065M3S

## THERMAL CHARACTERISTICS

Parameter	Symbol	Value	Unit
Thermal Resistance, Junction-to-Case (Note 3)	$R_{\theta JC}$	0.45	$^{\circ}\text{C}/\text{W}$

3. The entire application environment impacts the thermal resistance values shown, they are not constants and are only valid for the particular conditions noted.

## RECOMMENDED OPERATING CONDITIONS

Parameter	Symbol	Value	Unit
Operation Values of Gate-to-Source Voltage	$V_{GSop}$	-3/18	V

Functional operation above the stresses listed in the Recommended Operating Ranges is not implied. Extended exposure to stresses beyond the Recommended Operating Ranges limits may affect device reliability.

## ELECTRICAL CHARACTERISTICS ( $T_J = 25^{\circ}\text{C}$ unless otherwise specified)

Parameter	Symbol	Test Conditions	Min	Typ	Max	Unit
-----------	--------	-----------------	-----	-----	-----	------

### OFF CHARACTERISTICS

Drain-to-Source Breakdown Voltage	$V_{(BR)DSS}$	$V_{GS} = 0\text{ V}, I_D = 1\text{ mA}, T_J = 25^{\circ}\text{C}$	650	-	-	V
Zero Gate Voltage Drain Current	$I_{DSS}$	$V_{DS} = 650\text{ V}, T_J = 25^{\circ}\text{C}$	-	-	10	$\mu\text{A}$
		$V_{DS} = 650\text{ V}, T_J = 175^{\circ}\text{C}$ (Note 5)	-	-	500	$\mu\text{A}$
Gate-to-Source Leakage Current	$I_{GSS}$	$V_{GS} = -10\text{ V}, V_{DS} = 0\text{ V}$	-1	-	-	$\mu\text{A}$
		$V_{GS} = +22\text{ V}, V_{DS} = 0\text{ V}$	-	-	1	

### ON CHARACTERISTICS

Drain-to-Source On Resistance	$R_{DS(on)}$	$V_{GS} = 18\text{ V}, I_D = 29\text{ A}, T_J = 25^{\circ}\text{C}$	-	17	23.4	m $\Omega$
		$V_{GS} = 18\text{ V}, I_D = 29\text{ A}, T_J = 175^{\circ}\text{C}$ (Note 5)	-	26	-	
		$V_{GS} = 15\text{ V}, I_D = 29\text{ A}, T_J = 25^{\circ}\text{C}$	-	22	-	
		$V_{GS} = 15\text{ V}, I_D = 29\text{ A}, T_J = 175^{\circ}\text{C}$ (Note 5)	-	29	-	
Gate Threshold Voltage	$V_{GS(TH)}$	$V_{GS} = V_{DS}, I_D = 15\text{ mA}, T_J = 25^{\circ}\text{C}$	2.0	2.7	4.0	V
Forward Transconductance	$g_{FS}$	$V_{DS} = 10\text{ V}, I_D = 29\text{ A}$ (Note 5)	-	19	-	S

### CHARGES, CAPACITANCES & GATE RESISTANCE

Input Capacitance	$C_{ISS}$	$V_{DS} = 400\text{ V}, V_{GS} = 0\text{ V}, f = 1\text{ MHz}$ (Note 5)	-	2735	-	pF
Output Capacitance	$C_{OSS}$		-	208	-	
Reverse Transfer Capacitance	$C_{RSS}$		-	18	-	
Total Gate Charge	$Q_{G(TOT)}$	$V_{DD} = 400\text{ V}, I_D = 29\text{ A}, V_{GS} = -3/18\text{ V}$ (Note 5)	-	100	-	nC
Gate-to-Source Charge	$Q_{GS}$		-	26	-	
Gate-to-Drain Charge	$Q_{GD}$		-	25	-	
Gate Resistance	$R_G$	$f = 1\text{ MHz}$	-	2.8	-	$\Omega$

### SWITCHING CHARACTERISTICS

Turn-On Delay Time	$t_{d(ON)}$	$V_{GS} = -3/18\text{ V}, V_{DD} = 400\text{ V}, I_D = 30\text{ A}, R_G = 4.7\text{ }\Omega, T_J = 25^{\circ}\text{C}, L_{stray} = 13\text{ nH}$ (Notes 4, 5)	-	25	-	ns
Turn-Off Delay Time	$t_{d(OFF)}$		-	54	-	
Rise Time	$t_r$		-	17	-	
Fall Time	$t_f$		-	10.5	-	
Turn-On Switching Loss	$E_{ON}$		-	146	-	$\mu\text{J}$
Turn-Off Switching Loss	$E_{OFF}$		-	55	-	
Total Switching Loss	$E_{TOT}$		-	201	-	

# NTT2016N065M3S

## ELECTRICAL CHARACTERISTICS ( $T_J = 25\text{ }^\circ\text{C}$ unless otherwise specified) (continued)

Parameter	Symbol	Test Conditions	Min	Typ	Max	Unit
<b>SWITCHING CHARACTERISTICS</b>						
Turn-On Delay Time	$t_{d(ON)}$	$V_{GS} = -3/18\text{ V}$ , $V_{DD} = 400\text{ V}$ , $I_D = 30\text{ A}$ , $R_G = 4.7\text{ }\Omega$ , $T_J = 175\text{ }^\circ\text{C}$ , $L_{stray} = 13\text{ nH}$ (Notes 4, 5)	-	30.6	-	ns
Turn-Off Delay Time	$t_{d(OFF)}$		-	63	-	
Rise Time	$t_r$		-	16	-	
Fall Time	$t_f$		-	11.5	-	
Turn-On Switching Loss	$E_{ON}$		-	150	-	$\mu\text{J}$
Turn-Off Switching Loss	$E_{OFF}$		-	65	-	
Total Switching Loss	$E_{TOT}$		-	216	-	

## SOURCE-TO-DRAIN DIODE CHARACTERISTICS

Forward Diode Voltage	$V_{SD}$	$I_{SD} = 29\text{ A}$ , $V_{GS} = -3\text{ V}$ , $T_J = 25\text{ }^\circ\text{C}$	-	4.5	6.0	V
		$I_{SD} = 29\text{ A}$ , $V_{GS} = -3\text{ V}$ , $T_J = 175\text{ }^\circ\text{C}$ (Note 5)	-	4.2	-	
Reverse Recovery Time	$t_{RR}$	$V_{GS} = -3\text{ V}$ , $I_S = 29\text{ A}$ , $dI/dt = 1000\text{ A}/\mu\text{s}$ , $V_{DS} = 400\text{ V}$ , $T_J = 25\text{ }^\circ\text{C}$ (Note 5)	-	23	-	ns
Charge Time	$t_a$		-	13	-	
Discharge Time	$t_b$		-	10	-	
Reverse Recovery Charge	$Q_{RR}$		-	146	-	nC
Reverse Recovery Energy	$E_{REC}$		-	12	-	$\mu\text{J}$
Peak Reverse Recovery Current	$I_{RRM}$		-	11	-	A

Product parametric performance is indicated in the Electrical Characteristics for the listed test conditions, unless otherwise noted. Product performance may not be indicated by the Electrical Characteristics if operated under different conditions.

4.  $E_{ON}/E_{OFF}$  result is with body diode.

5. Defined by design, not subject to production test.

TYPICAL CHARACTERISTICS

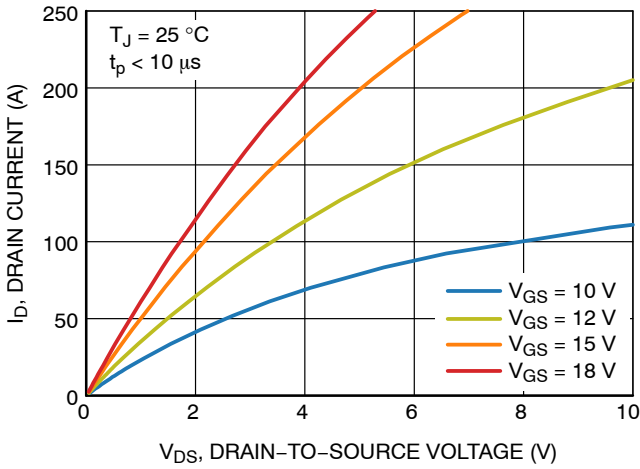

Figure 1. Output Characteristics

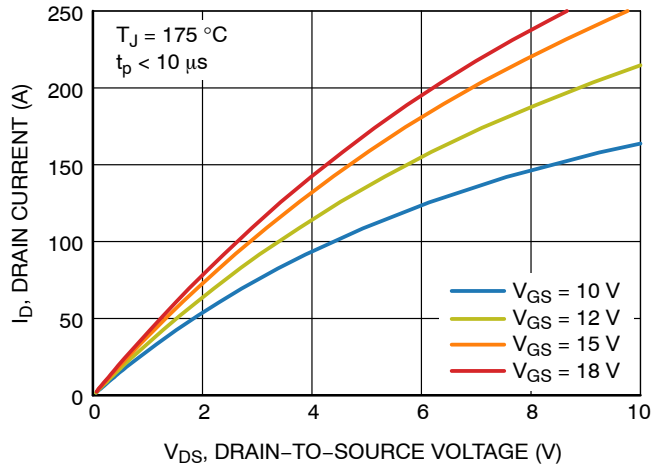

Figure 2. Output Characteristics

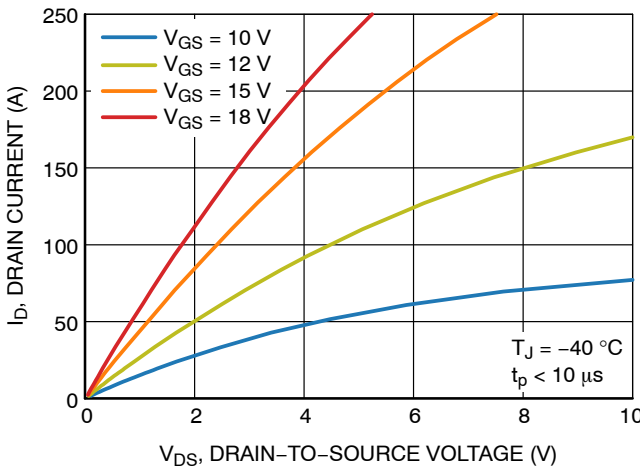

Figure 3. Output Characteristics

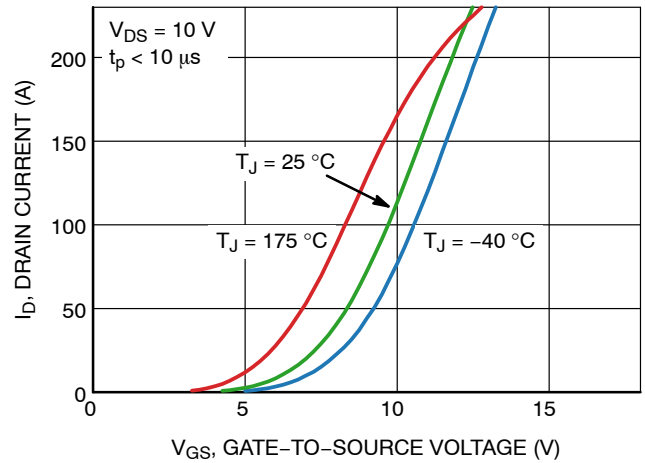

Figure 4.  $I_D$  vs.  $V_{GS}$

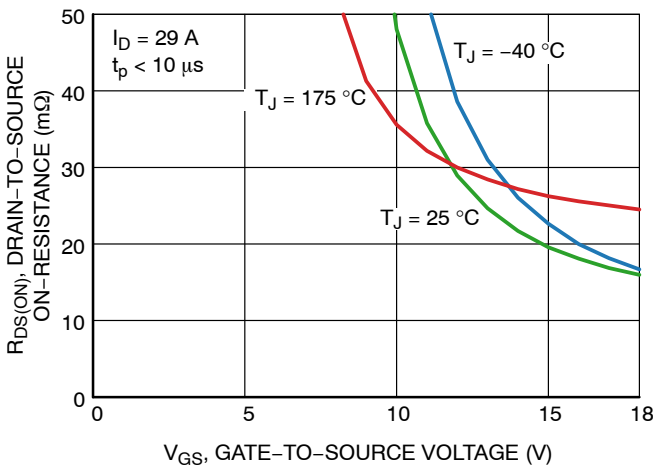

Figure 5.  $R_{DS(ON)}$  vs.  $V_{GS}$

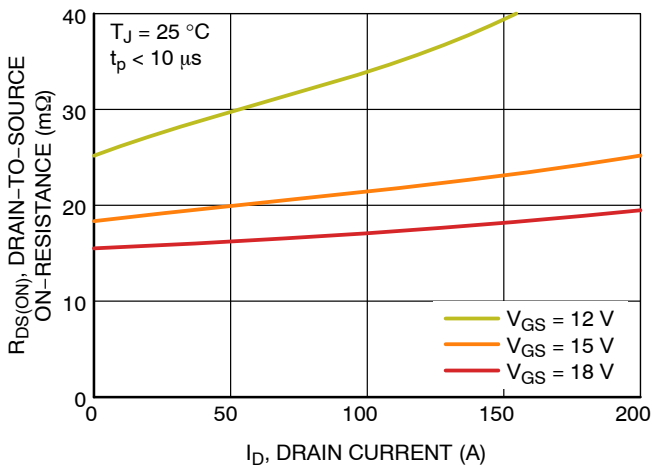

Figure 6.  $R_{DS(ON)}$  vs.  $I_D$

TYPICAL CHARACTERISTICS

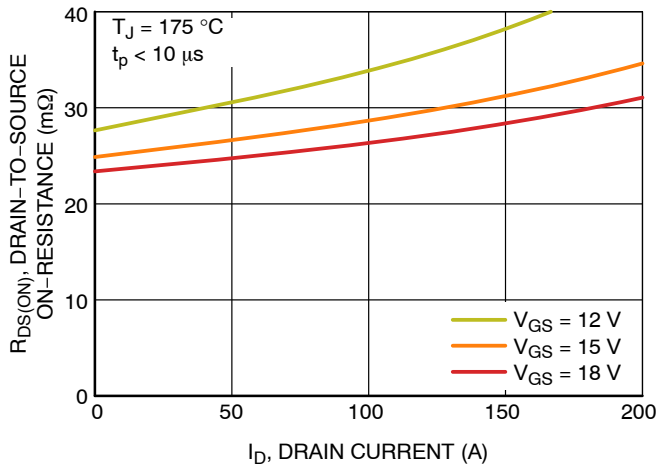

Figure 7.  $R_{DS(ON)}$  vs.  $I_D$

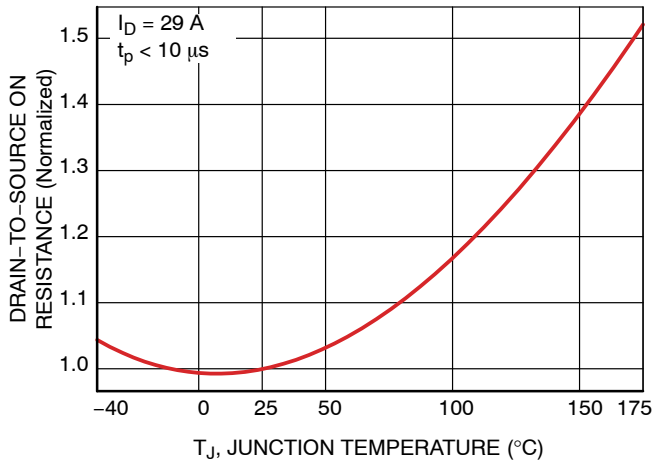

Figure 8.  $R_{DS(ON)}$  vs.  $T_J$

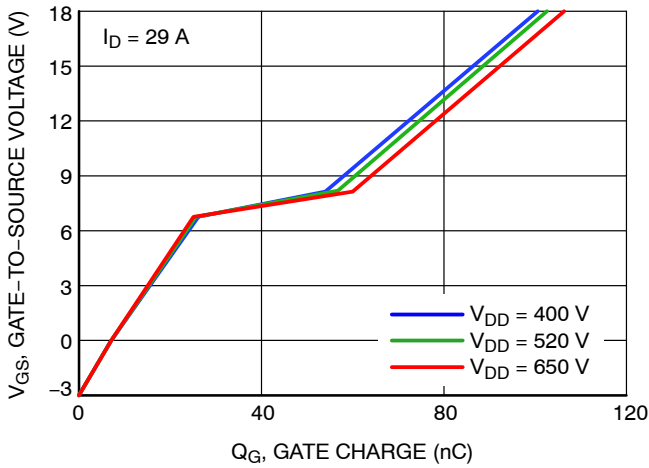

Figure 9. Gate Charge Characteristics

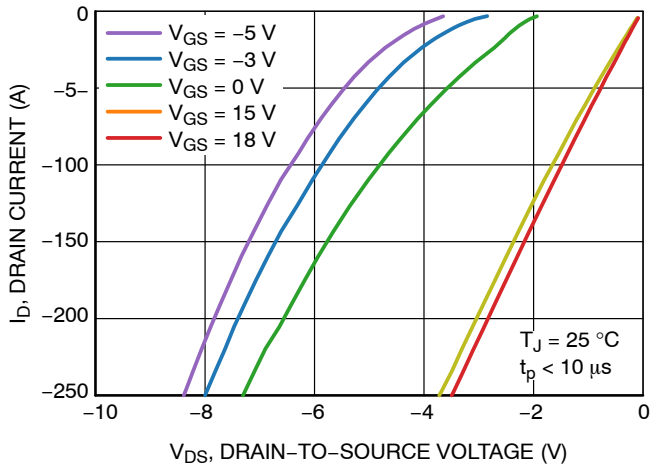

Figure 10.  $I_D$  vs.  $V_{DS}$

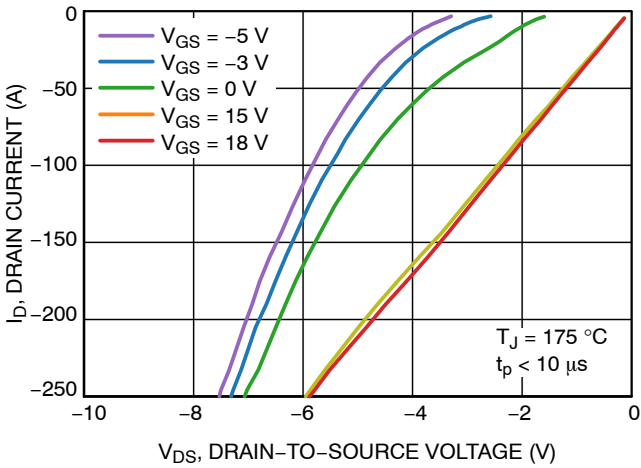

Figure 11.  $I_D$  vs.  $V_{DS}$

TYPICAL CHARACTERISTICS

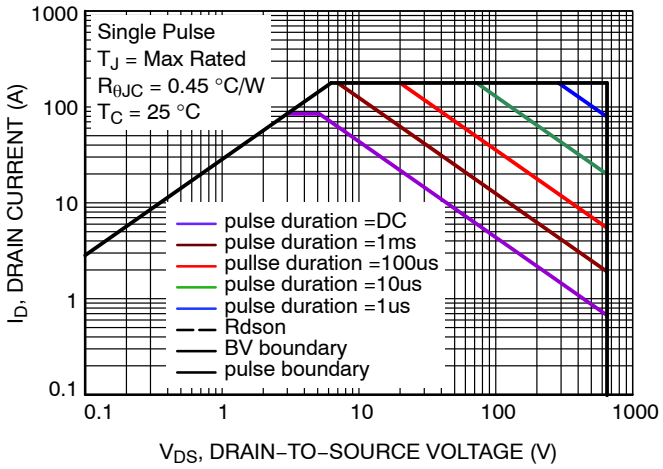

Figure 12. Safe Operating Area

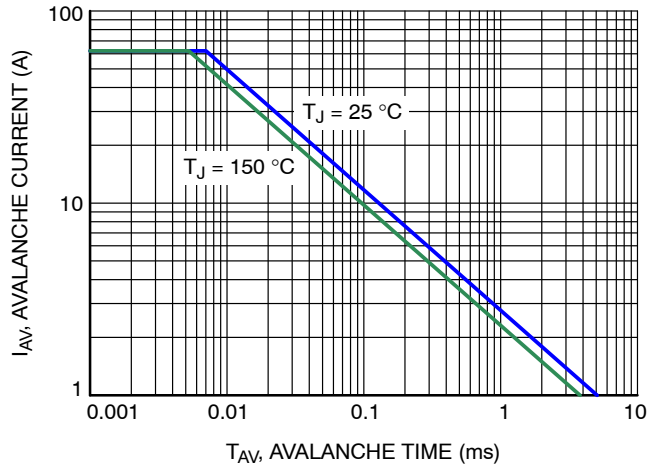

Figure 13. Avalanche Current vs. Pulse Time (UIS)

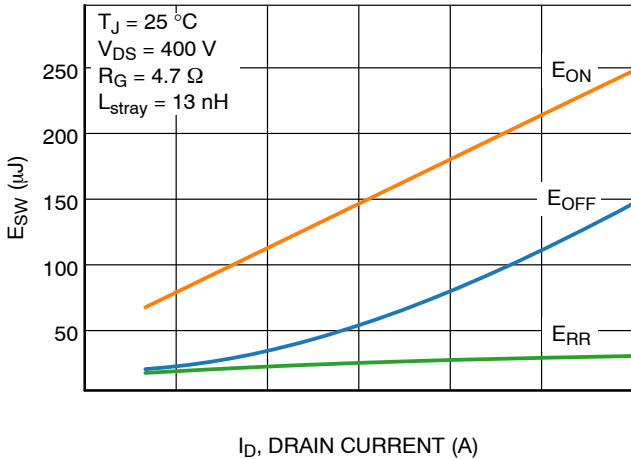

Figure 14.  $E_{SW}$  vs.  $I_D$

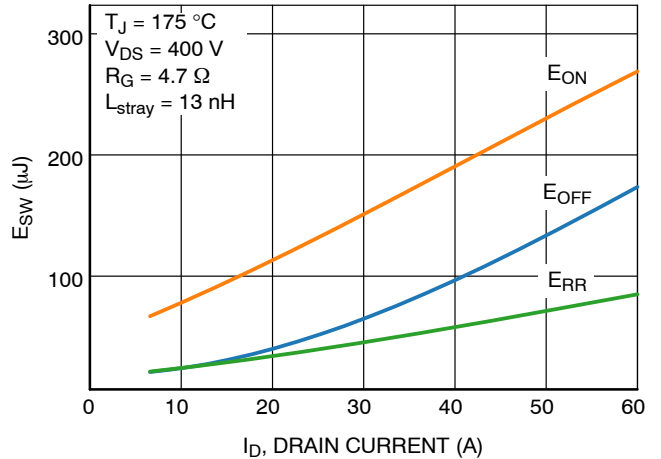

Figure 15.  $E_{SW}$  vs.  $I_D$

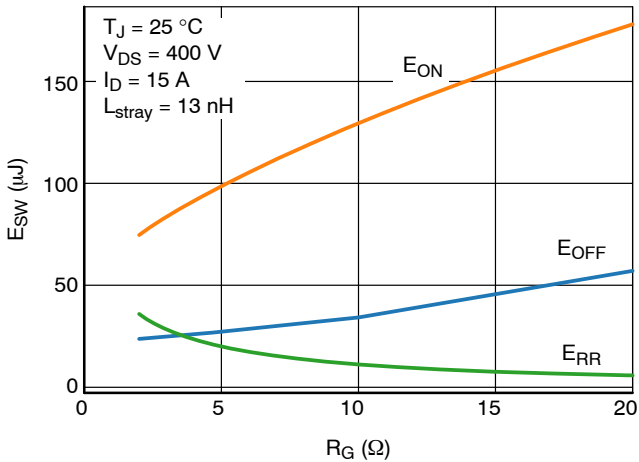

Figure 16.  $E_{SW}$  vs.  $R_G$

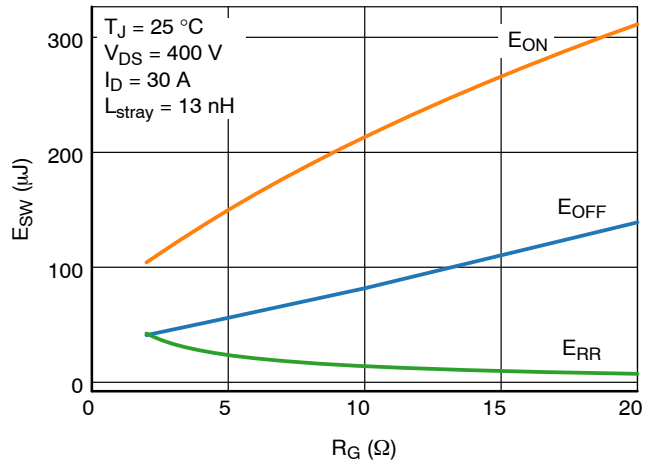

Figure 17.  $E_{SW}$  vs.  $R_G$

# NTT2016N065M3S

## TYPICAL CHARACTERISTICS

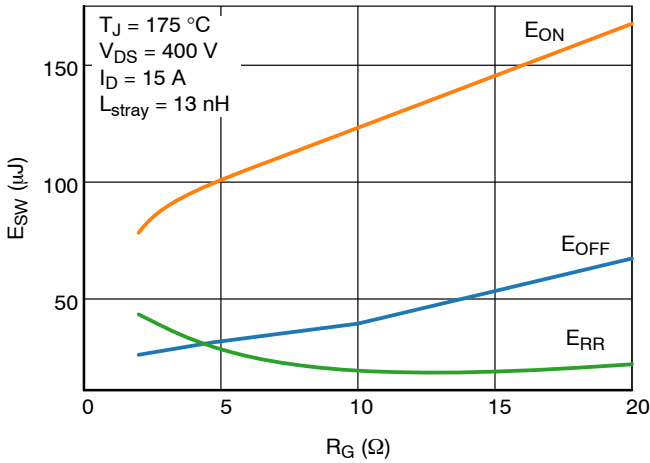

Figure 18.  $E_{SW}$  vs.  $R_G$

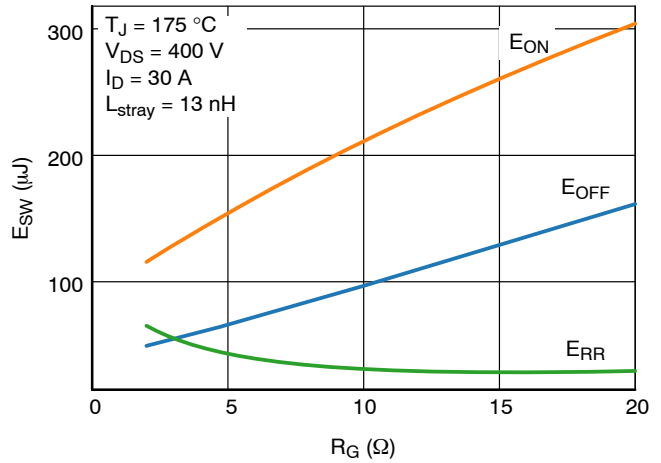

Figure 19.  $E_{SW}$  vs.  $R_G$

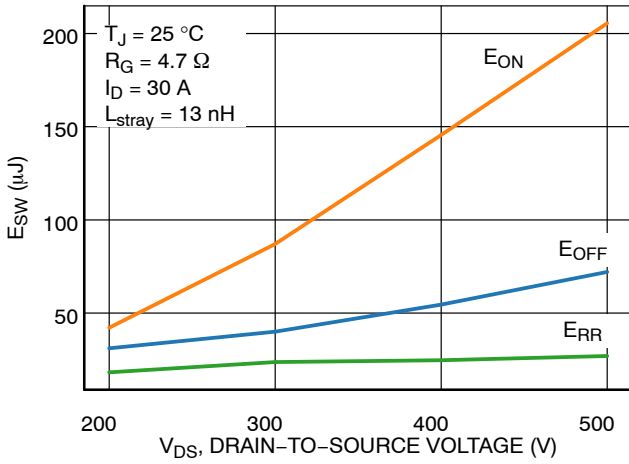

Figure 20.  $E_{SW}$  vs.  $V_{DS}$

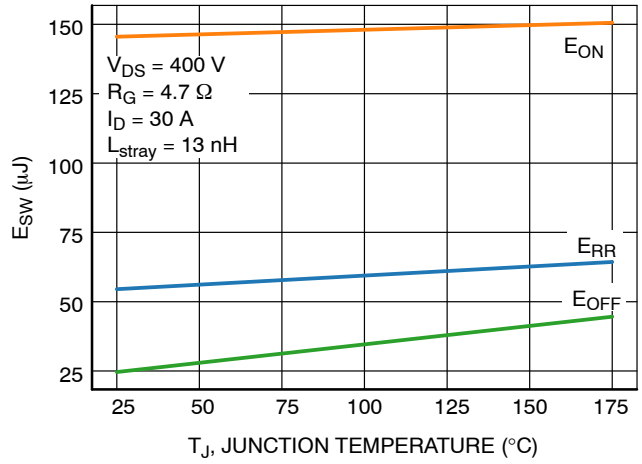

Figure 21.  $E_{SW}$  vs.  $T_J$

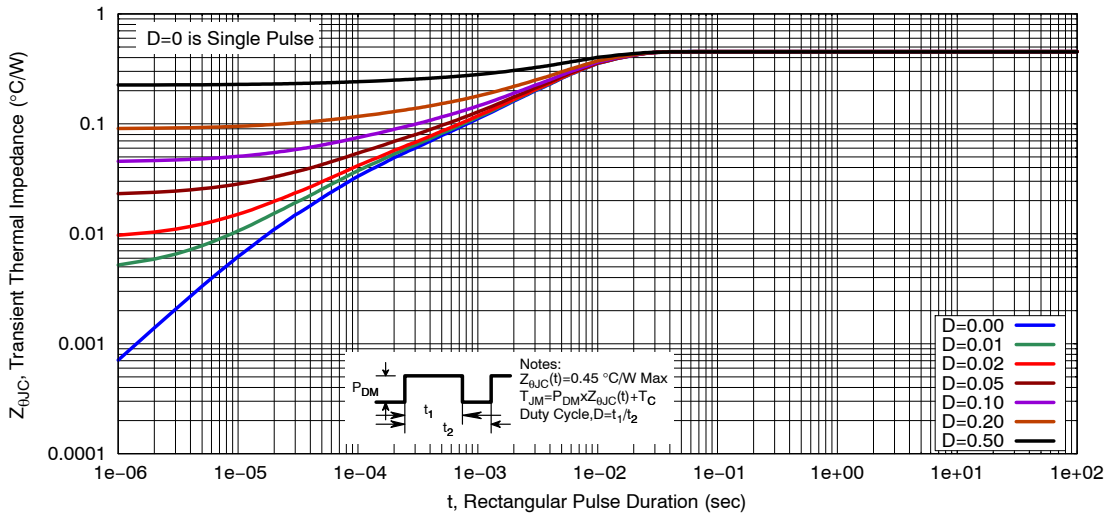

Figure 22. Thermal Response Characteristics

# NTT2016N065M3S

## REVISION HISTORY

Revision	Description of Changes	Date
0	Initial data sheet release.	09/29/2025
1	Edits to figures 5 and 8	10/10/2025

# NTT2016N065M3S

## PACKAGE DIMENSIONS

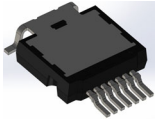

**T2PAK-7 11.80x14.00x3.50, 1.27P**  
**CASE 763AC**  
**ISSUE A**

DATE 20 JUN 2025

**NOTES:**

1. DIMENSIONING AND TOLERANCING AS PER ASME Y14.5M, 2018.
2. CONTROLLING DIMENSION: MILLIMETERS.
3. DIMENSIONS b, b2, b3 AND c TO BE MEASURED ON FLAT SECTION OF THE LEAD BETWEEN 0.13 AND 0.25mm FROM LEAD TIP.
4. COPLANARITY APPLIES TO THE EXPOSED PAD AS WELL AS THE TERMINALS.
5. POSITIONAL TOLERANCE APPLIES TO THE TERMINALS AND EXPOSED PAD.
6. A1 IS DEFINED AS THE VERTICAL DISTANCE FROM THE SEATING PLANE TO THE LOWEST POINT OF THE PACKAGE BODY.
7. DIMENSIONS D AND E ARE DETERMINED AT THE OUTERMOST EXTREMES OF THE PLASTIC BODY.
8. ALLOWABLE ENCROACHED FLASH ON HEAT SINK AREA MAXIMUM OF 0.05mm.
9. EJECTOR PINS  $\phi$ 12.5mm REF.

MILLIMETERS			
DIM	MIN	NOM	MAX
A	3.53	3.63	3.73
A1	0.07	0.13	0.18
A2	3.40	3.50	3.60
b	0.50	0.60	0.70
b2	0.50	0.75	1.00
b3	0.80	0.90	1.00
c	0.40	0.50	0.60
c2	0.40	0.50	0.60
D	11.80 BSC		
D2	8.90	9.00	9.10
D3	3.00	3.10	3.20
D4	3.80	3.90	4.00
D5	2.10	2.20	2.30
E	14.00 BSC		
E2	12.30	12.40	12.50
e	1.27 BSC		

MILLIMETERS			
DIM	MIN	NOM	MAX
H	18.00	18.50	19.00
H1	13.80	14.00	14.20
L	2.42	2.52	2.62
L1	4.53 REF		
L2	0.25 BSC		
L3	3.00	3.10	3.20
R	0.80	---	1.00
$\emptyset$	0*	---	8*
$\emptyset$ 1	0*	---	8*
TOLERANCE FORM AND POSITION			
aaa	0.10		
bbb	0.10		
ccc	0.10		
ddd	0.05		
eee	0.05		

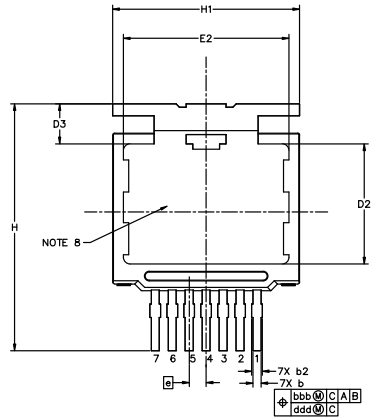

TOP VIEW

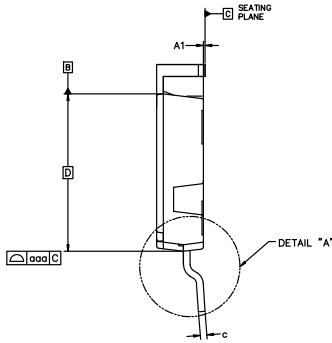

SIDE VIEW

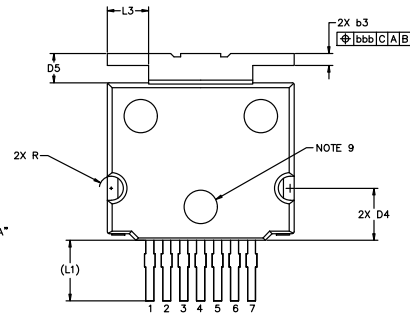

BOTTOM VIEW

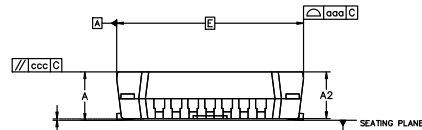

FRONT VIEW



END VIEW

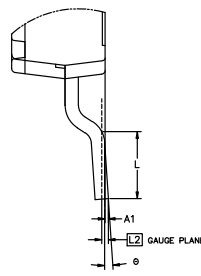

DETAIL "A"  
SCALE 2:1

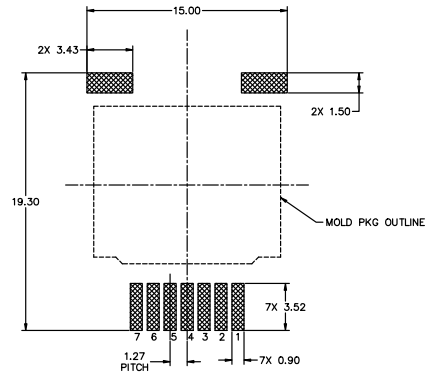

**RECOMMENDED MOUNTING FOOTPRINT**

\*For additional information on our Pb-Free strategy and soldering details, please download the onsemi Soldering and Mounting Techniques Reference Manual, SOLDERRM/D.

**GENERIC MARKING DIAGRAM\***

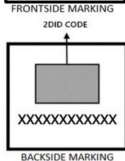

XXXX = Specific Device Code  
 A = Assembly Location  
 Y = Year  
 WW = Work Week  
 ZZ = Assembly Lot Code

\*This information is generic. Please refer to device data sheet for actual part marking. Pb-Free indicator, "G" or microdot "•", may or may not be present. Some products may not follow the Generic Marking.

**onsemi**, **Onsemi**, and other names, marks, and brands are registered and/or common law trademarks of Semiconductor Components Industries, LLC dba "**onsemi**" or its affiliates and/or subsidiaries in the United States and/or other countries. **onsemi** owns the rights to a number of patents, trademarks, copyrights, trade secrets, and other intellectual property. A listing of **onsemi**'s product/patent coverage may be accessed at [www.onsemi.com/site/pdf/Patent-Marking.pdf](http://www.onsemi.com/site/pdf/Patent-Marking.pdf). **onsemi** reserves the right to make changes at any time to any products or information herein, without notice. The information herein is provided "as-is" and **onsemi** makes no warranty, representation or guarantee regarding the accuracy of the information, product features, availability, functionality, or suitability of its products for any particular purpose, nor does **onsemi** assume any liability arising out of the application or use of any product or circuit, and specifically disclaims any and all liability, including without limitation special, consequential or incidental damages. Buyer is responsible for its products and applications using **onsemi** products, including compliance with all laws, regulations and safety requirements or standards, regardless of any support or applications information provided by **onsemi**. "Typical" parameters which may be provided in **onsemi** data sheets and/or specifications can and do vary in different applications and actual performance may vary over time. All operating parameters, including "Typicals" must be validated for each customer application by customer's technical experts. **onsemi** does not convey any license under any of its intellectual property rights nor the rights of others. **onsemi** products are not designed, intended, or authorized for use as a critical component in life support systems or any FDA Class 3 medical devices or medical devices with a same or similar classification in a foreign jurisdiction or any devices intended for implantation in the human body. Should Buyer purchase or use **onsemi** products for any such unintended or unauthorized application, Buyer shall indemnify and hold **onsemi** and its officers, employees, subsidiaries, affiliates, and distributors harmless against all claims, costs, damages, and expenses, and reasonable attorney fees arising out of, directly or indirectly, any claim of personal injury or death associated with such unintended or unauthorized use, even if such claim alleges that **onsemi** was negligent regarding the design or manufacture of the part. **onsemi** is an Equal Opportunity/Affirmative Action Employer. This literature is subject to all applicable copyright laws and is not for resale in any manner.

#### ADDITIONAL INFORMATION

**TECHNICAL PUBLICATIONS:**

Technical Library: [www.onsemi.com/design/resources/technical-documentation](http://www.onsemi.com/design/resources/technical-documentation)  
onsemi Website: [www.onsemi.com](http://www.onsemi.com)

**ONLINE SUPPORT:** [www.onsemi.com/support](http://www.onsemi.com/support)

For additional information, please contact your local Sales Representative at [www.onsemi.com/support/sales](http://www.onsemi.com/support/sales)