

# XCL247/XCL248 Series

ETR28034-002a

## 36V, 600mA Inductor Built-in Step-down “micro DC/DC” Converter

### ■ GENERAL DESCRIPTION

The XCL247/XCL248 Series is a small (3.0mm×3.0mm, h=1.7mm) 36V, 600mA step-down DC/DC converter with an integrated control IC and coil. Integrating the coil makes for easier circuit board layout and minimizes malfunction and noise from the component and wiring layout.

The input voltage range is 3.0V to 36.0V, and the switching frequency is 1.2MHz, making it possible to supply a stable voltage with high efficiency. The output voltage can be changed from 2.8V to 6.0V using an external resistor, so the same part number can be used for multiple power lines.

By connecting a resistor and capacitance to the EN/SS terminal, it is possible to externally adjust the soft start time longer than the internal soft start.

The power good function also monitors the output voltage status. This soft start external adjustment function and power good function make it easy to configure the power supply sequence.

The built-in current limiter and thermal shutdown functions as protection functions make it safe to use.

### ■ APPLICATIONS

- Industrial automation
- Industrial sensors
- Security systems
- Home appliances
- 4~20mA current loop
- High-voltage LDO replacement
- General-purpose power supply  
/General-purpose POL

### ■ FEATURES

Input Voltage Range	: 3.0V ~ 36.0V (Absolute Max 40.0V)
Peak voltage	: 46.0V (Applied Time $\leq$ 400ms)
Output Voltage Range	: 2.8V ~ 6.0V
FB Voltage	: $0.75V \pm 1.5\%$
Output Current	: 600mA
Oscillation Frequency	: 1.2MHz
Quiescent Current	: 11 $\mu$ A (XCL248)
Efficiency	: 88% ( $V_{IN}=12V, V_{OUT}=5V, I_{OUT}=300mA$ )
Control Methods	: F-PWM Control (XCL247) PWM/PFM Control (XCL248)
Protection functions	: Current Limit Thermal Shutdown
Functions	: Soft start (external adjustment) Power Good
Output Capacitor	: Ceramic Capacitor
Operating Ambient Temperature	: $-40^{\circ}C \sim 105^{\circ}C$
Packages	: DFN3030-10B (3.0x3.0x1.7mm)
Environmentally Friendly	: EU RoHS Compliant, Pb Free

### ■ TYPICAL APPLICATION CIRCUIT

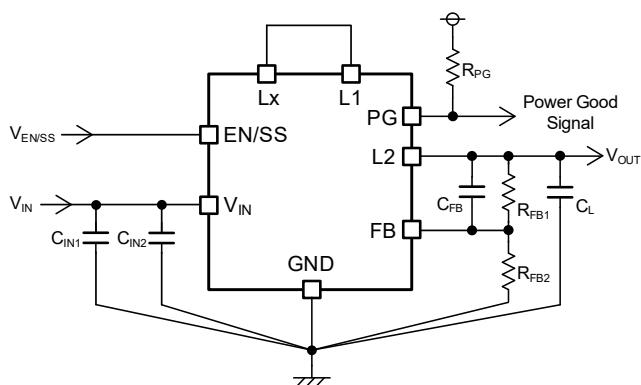

### ■ TYPICAL PERFORMANCE CHARACTERISTICS

$$V_{IN}=12V, V_{OUT}=5.0V$$

$$C_{IN1}=2.2\mu F (C2012X7R1H225K125AC), C_{IN2}=0.1\mu F (C1608X7R1H104K080AE)$$

$$C_L=47\mu F \times 2 (MSASL21G5B5476MTNA01)$$

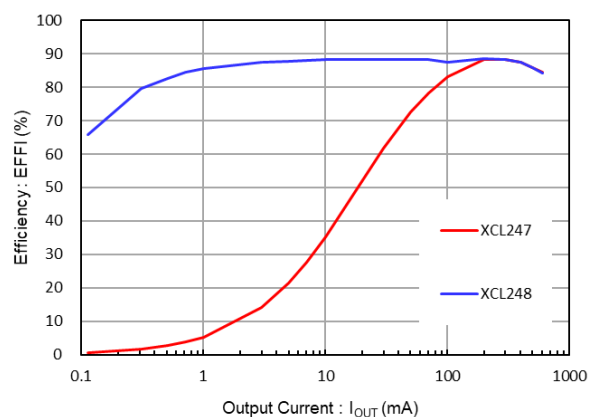



## ■ PRODUCT CLASSIFICATION

### ● Ordering Information

XCL247①②③④⑤⑥-⑦ : F-PWM Control

XCL248①②③④⑤⑥-⑦ : PWM/PFM Control

DESIGNATOR	ITEM	SYMBOL	DESCRIPTION
①	Type	B	Refer to Selection Guide
②③	FB Voltage	0K	0.75V
④	Oscillation Frequency	1	1.2MHz
⑤⑥-⑦	Packages (Order Unit)	H2-G <sup>(*)</sup>	DFN3030-10B (3,000pcs/Reel)

<sup>(\*)</sup> "Halogen and Antimony free" as well as being fully EU RoHS compliant.

### ● Selection Guide

FUNCTION	B TYPE
Enable	Yes
UVLO	Yes
Thermal Shutdown	Yes
Soft Start	Yes
Power-Good	Yes
Current Limiter (Automatic Recovery)	Yes

## PIN CONFIGURATION

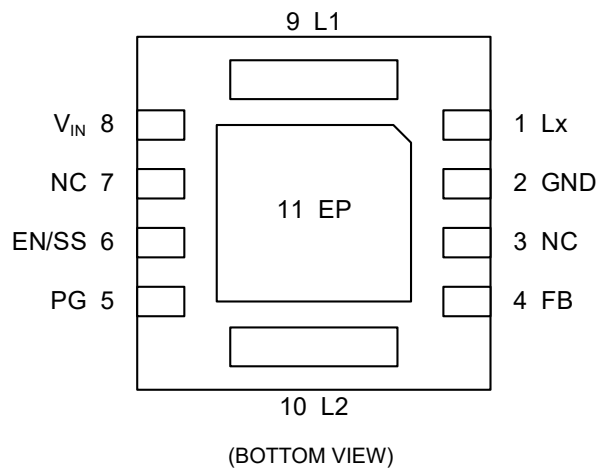

## PIN ASSIGNMENT

PIN NUMBER	PIN NAME	FUNCTION
1	Lx	Switching Output
2	GND	Ground
3	NC	No Connection
4	FB	Output Voltage Sense
5	PG	Power good Output
6	EN/SS	Enable, Soft-Start
7	NC	No Connection
8	V <sub>IN</sub>	Power Input
9	L1	Inductor Electrodes
10	L2	Inductor Electrodes
11	EP	Exposed thermal pad. The Exposed pad is recommended to be connected to GND (Pin2)

## FUNCTION CHART

PIN NAME	SIGNAL	STATUS
EN/SS	H	Active
	L	Stand-by
	OPEN	Stand-by

PIN NAME	CONDITION	SIGNAL	
PG	EN/SS = H	$V_{FB} > V_{PGDET}$	H (High impedance)
		$V_{FB} \leq V_{PGDET}$	L (Low impedance)
		Thermal Shutdown	L (Low impedance)
	EN/SS = L	UVLO ( $V_{IN} < V_{UVLO}$ )	Undefined State
		Stand-by	L (Low impedance)

## ■ ABSOLUTE MAXIMUM RATINGS

PARAMETER	SYMBOL	RATINGS	UNITS
V <sub>IN</sub> Pin Voltage	V <sub>IN</sub>	-0.3 ~ 40.0	V
EN/SS Pin Voltage	V <sub>EN/SS</sub>	-0.3 ~ 40.0	V
FB Pin Voltage	V <sub>FB</sub>	-0.3 ~ 6.2	V
PG Pin Voltage	V <sub>PG</sub>	-0.3 ~ 6.2	V
PG Pin Current	I <sub>PG</sub>	8	mA
Lx Pin Voltage	V <sub>Lx</sub>	-0.3 ~ V <sub>IN</sub> + 0.3 or 40.0 <sup>(*)1</sup>	V
Power Dissipation (Ta=25°C)	P <sub>d</sub>	1950 (JESD51-7 Board) <sup>(*)2</sup>	mW
V <sub>IN</sub> Pin Surge Voltage	V <sub>IN_SURGE</sub>	46.0 <sup>(*)3</sup>	V
EN/SS Pin Surge Voltage	V <sub>EN/SS_SURGE</sub>	46.0 <sup>(*)3</sup>	V
Junction Temperature	T <sub>j</sub>	-40 ~ 125	°C
Storage Temperature	T <sub>stg</sub>	-55 ~ 150	°C

All voltages are described based on the GND pin.

<sup>(\*)1</sup> The maximum value should be either V<sub>IN</sub>+0.3V or 40.0V in the lowest.

<sup>(\*)2</sup> The power dissipation figure shown is PCB mounted and is for reference only.

Please refer to PACKAGING INFORMATION for the mounting conditions.

<sup>(\*)3</sup> Applied Time ≤ 400ms

## RECOMMENDED OPERATING CONDITIONS

PARAMETER		SYMBOL	MIN.	TYP.	MAX.	UNITS	
Setting Output Voltage Range		$V_{OUTSET}$	2.8	-	6.0	V	
Input Voltage		$V_{IN}$	3.0	-	36.0	V	
Output Current		$I_{OUT}$	0.0	-	600	mA	
EN/SS Pin Voltage		$V_{EN/SS}$	0.0	-	36.0	V	
PG Pull-up Voltage		$V_{PG}$	0.0	-	5.5	V	
PG Pull-up Resistor		$R_{PG}$	5	100	-	k $\Omega$	
Operating Ambient Temperature		$T_{opr}$	-40	-	105	$^{\circ}\text{C}$	
Input Capacitor (Effective Value)		$C_{IN}$	0.5	-	1000 <sup>(*2)</sup>	$\mu\text{F}$	
Output Capacitor (Effective Value) <sup>(*1)</sup>	$V_{IN} < 20\text{V}$	$V_{OUTSET} \leq 3.3\text{V}$	$C_L$	-	1000 <sup>(*3)</sup>	$\mu\text{F}$	
		$3.3\text{V} < V_{OUTSET} \leq 6\text{V}$					13.2
	$20\text{V} \leq V_{IN}$	$V_{OUTSET} \leq 3.3\text{V}$					10.4
		$3.3\text{V} < V_{OUTSET} \leq 6\text{V}$					24.6
					29.6		

All voltages are described based on the GND pin.

- (\*1) Some ceramic capacitors have an effective capacitance that is significantly lower than the nominal value due to the applied DC bias and ambient temperature. For the input / output capacitance of this IC, use an appropriate ceramic capacitor according to the DC bias usage conditions (ambient temperature, input / output voltage) so that the effective capacitance value is equal to or higher than the recommended component.
- (\*2) If using a large-capacity capacitor such as an electrolytic capacitor or tantalum capacitor as the input capacitance, place a low ESR ceramic capacitor in parallel. If a ceramic capacitor is not placed, high-frequency voltage fluctuations will increase and the IC may malfunction.
- (\*3) If a large-capacity capacitor is used as output capacitor, the output stability may be reduced, and the ripple voltage may increase. Even if a large-capacity capacitor such as an electrolytic capacitor or tantalum capacitor is used as output capacitor, please place a low-ESR ceramic capacitor in parallel. Even if the capacitance is within the recommended range, the output stability may be reduced depending on the type and ESR etc. of the capacitor used, so please thoroughly test it on the actual equipment before use.

## ■ ELECTRICAL CHARACTERISTICS

Ta=25°C

PARAMETER	SYMBOL	CONDITIONS	MIN.	TYP.	MAX.	UNIT	CIRCUIT	
Operating Input Voltage Range	V <sub>IN</sub>	-	3.0	-	36.0	V	-	
Setting Output Voltage Range	V <sub>OUTSET</sub>	-	2.8	-	6.0	V	-	
FB Voltage	V <sub>FBE</sub>	V <sub>FB</sub> =0.739V→0.761V, V <sub>FB</sub> Voltage when Lx pin voltage changes from "H" to "L"	0.739	0.750	0.761	V	②	
Over Voltage Protection	V <sub>OV</sub>	-	-	0.81	-	V	-	
UVLO Detect Voltage	V <sub>UVLOD</sub>	V <sub>EN/SS</sub> =12V, V <sub>IN</sub> :2.80V→2.60V, V <sub>FB</sub> =0V V <sub>IN</sub> Voltage when Lx pin changes from "H" to "L"	2.6	2.7	2.8	V	②	
UVLO Release Voltage	V <sub>UVLOR</sub>	V <sub>EN/SS</sub> =12V, V <sub>IN</sub> :2.70V→2.90V, V <sub>FB</sub> =0V V <sub>IN</sub> Voltage when Lx pin changes from "L" to "H"	2.7	2.8	2.9	V	②	
Quiescent Current	I <sub>q</sub>	V <sub>FB</sub> =0.765V	XCL247	-	270	540	μA	④
			XCL248	-	11	19	μA	④
Stand-by Current	I <sub>STB</sub>	V <sub>IN</sub> =12V, V <sub>EN/SS</sub> =0V	-	0.6	1.2	μA	④	
Oscillation Frequency	f <sub>OSC</sub>	Connected to external components, I <sub>OUT</sub> =150mA	1.098	1.200	1.302	MHz	①	
Minimum Duty Cycle	D <sub>MIN</sub>	V <sub>FB</sub> =0.825V	-	-	0	%	②	
Maximum Duty Cycle	D <sub>MAX</sub>	V <sub>FB</sub> =0.675V	100	-	-	%	②	
Lx SW "H" On Resistance	R <sub>LxH</sub>	V <sub>FB</sub> =0.6V, I <sub>Lx</sub> =200mA	-	1.20	1.38	Ω	⑤	
Lx SW "L" On Resistance	R <sub>LxL</sub>	I <sub>Lx</sub> =200mA	-	0.60	0.70	Ω	-	
High side Current Limit <sup>(*)</sup>	I <sub>LIMH</sub>	V <sub>FB</sub> =V <sub>FBE</sub> ×0.98	1.1	1.4	-	A	-	
Internal Soft-Start Time	t <sub>SS1</sub>	V <sub>FB</sub> =0.71V	1.0	2.2	4.5	ms	②	
External Soft-Start Time	t <sub>SS2</sub>	V <sub>FB</sub> =0.71V, R <sub>SS</sub> =430kΩ, C <sub>SS</sub> =0.47μF	14	21	32	ms	③	

Test Condition : Unless otherwise stated, V<sub>IN</sub>=12V, V<sub>EN/SS</sub>=12V, V<sub>PG</sub>: OPEN <sup>(\*)</sup>

Peripheral component connection conditions (V<sub>OUT</sub>=5.0V) : R<sub>FB1</sub>=680kΩ, R<sub>FB2</sub>=120kΩ, C<sub>FB</sub>=15pF, C<sub>L</sub>=22μF, C<sub>IN</sub>=2.2μF

<sup>(\*)</sup> The current limit indicates the detection level of the peak current flowing through the coil.

## ELECTRICAL CHARACTERISTICS

Ta=25°C

PARAMETER	SYMBOL	CONDITIONS	MIN.	TYP.	MAX.	UNIT	CIRCUIT
PG detect Voltage	V <sub>PGDET</sub>	V <sub>FB</sub> =0.712V→0.638V, R <sub>PG</sub> :100kΩ pull-up to 5V, V <sub>FB</sub> Voltage when PG pin voltage changes from "H" to "L"	0.638	0.675	0.712	V	⑤
PG Output Voltage	V <sub>PG</sub>	V <sub>FB</sub> =0.6V, I <sub>PG</sub> =1mA	-	-	0.3	V	②
PFM Switch Current (XCL248)	I <sub>PFM</sub>	Connected to external components, I <sub>OUT</sub> =0mA	-	350	-	mA	①
FB Voltage Temperature Characteristics	$\frac{\Delta V_{FB}}{(\Delta T_{opr} \cdot V_{FBE})}$	-40°C ≤ T <sub>opr</sub> ≤ 105°C	-	±100	-	ppm/°C	②
FB "H" Current	I <sub>FBH</sub>	V <sub>IN</sub> =V <sub>EN/SS</sub> =36V, V <sub>FB</sub> =3.0V	-	0.0	0.1	μA	④
FB "L" Current	I <sub>FBL</sub>	V <sub>IN</sub> =V <sub>EN/SS</sub> =36V, V <sub>FB</sub> =0V	-	0.0	0.1	μA	④
EN/SS "H" Voltage	V <sub>EN/SSH</sub>	V <sub>EN/SS</sub> =0.3V→2.5V, V <sub>FB</sub> =0.71V EN/SS Voltage when Lx pin voltage changes from "L" to "H"	2.5	-	36.0	V	④
EN/SS "L" Voltage	V <sub>EN/SSL</sub>	V <sub>EN/SS</sub> =2.5V→0.3V, V <sub>FB</sub> =0.71V EN/SS Voltage when Lx pin voltage changes from "H" to "L"	GND	-	0.3	V	④
EN/SS "H" Current	I <sub>EN/SSH</sub>	V <sub>IN</sub> =V <sub>EN/SS</sub> =36V, V <sub>FB</sub> =0.825V	-	0.1	0.3	μA	④
EN/SS "L" Current	I <sub>EN/SSL</sub>	V <sub>IN</sub> =36V, V <sub>EN/SS</sub> =0V, V <sub>FB</sub> =0.825V	-	0.0	0.1	μA	④
Thermal Shutdown Temperature	T <sub>TSD</sub>	Junction Temperature	-	160	-	°C	-
Thermal Shutdown Hysteresis Width	T <sub>HYS</sub>	Junction Temperature	-	25	-	°C	-
Inductance	L	Test Freq.=1MHz	-	4.7	-	μH	-

Test Condition : Unless otherwise stated, V<sub>IN</sub>=12V, V<sub>EN/SS</sub>=12V, V<sub>PG</sub>:OPEN

## TEST CIRCUITS

CIRCUIT①

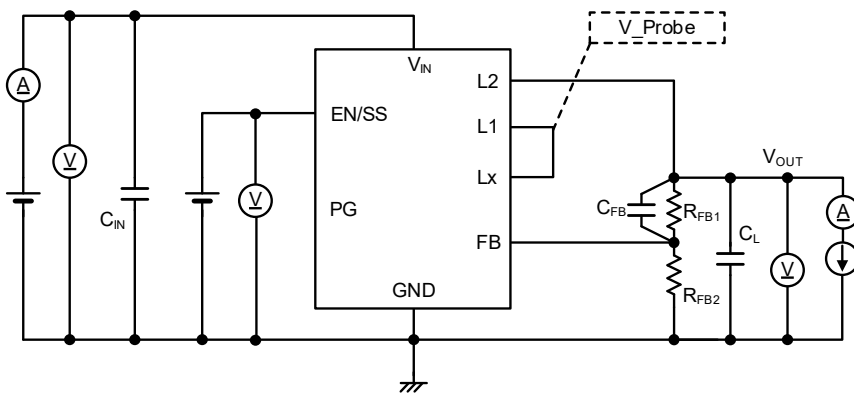

CIRCUIT②

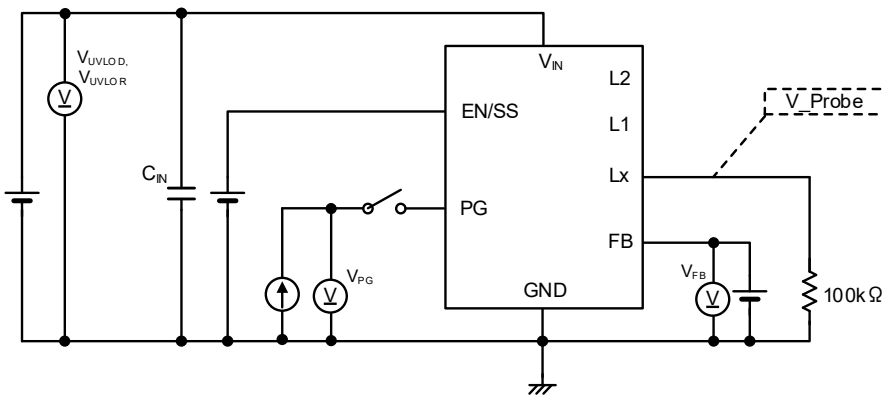

CIRCUIT③

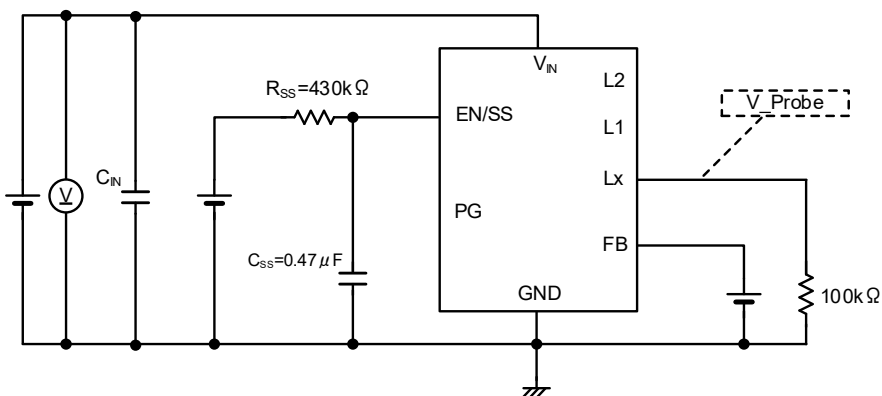

## TEST CIRCUITS

CIRCUIT④

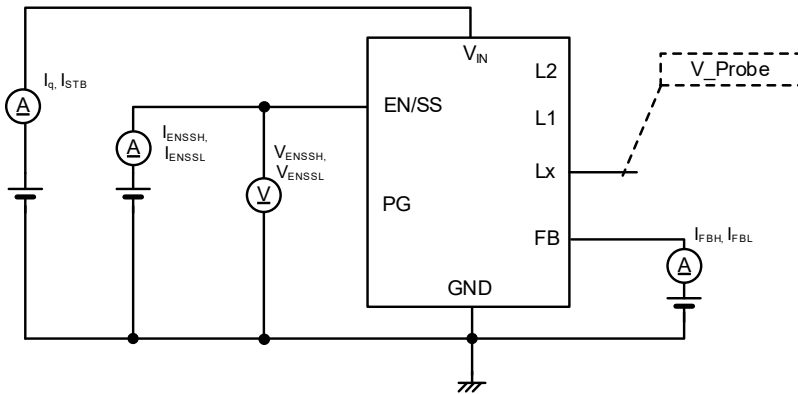

CIRCUIT⑤

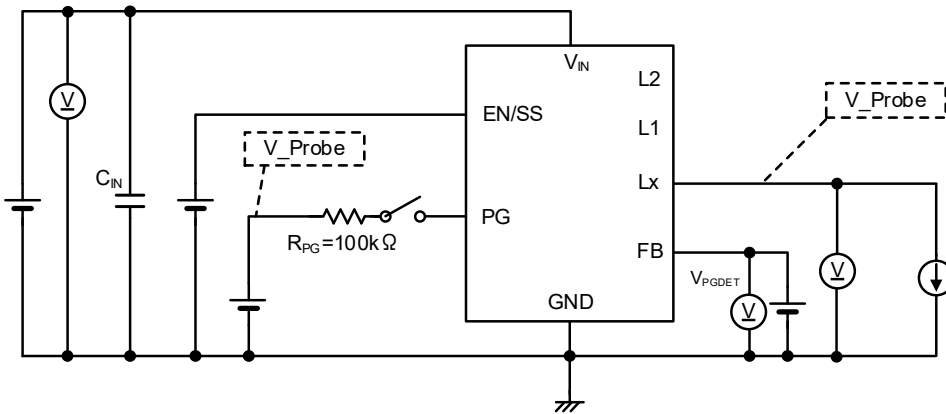

## ■ TYPICAL APPLICATION CIRCUIT / Parts Selection Method

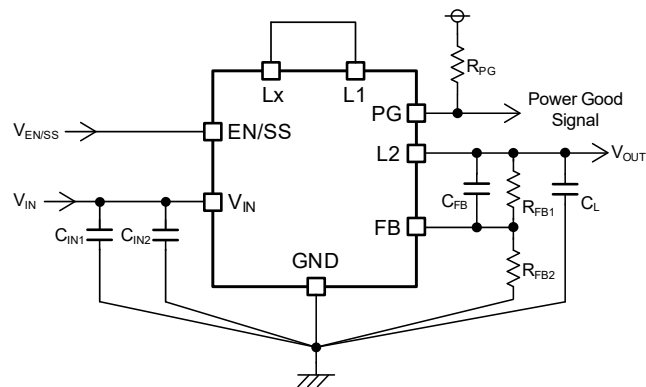

### 【Typical Example】

		MANUFACTURER	PRODUCT NUMBER	VALUE
$C_{IN1}$	-	TDK	C2012X7R1H225K125AC	2.2 $\mu$ F/50V
$C_{IN2}$	-	TDK	C1608X7R1H104K080AE	0.1 $\mu$ F/50V
$C_L$	$V_{IN} < 20V$	TDK	C2012X7R1A106K125AC	10 $\mu$ F/10V 2parallel
	$20V \leq V_{IN}$	TDK	C2012X5R1E226M125AC	22 $\mu$ F/25V 3parallel
		Murata	GRM21BC81C226ME44	22 $\mu$ F/16V 3parallel
		TDK	C2012X5R1A476M125AC	47 $\mu$ F/10V 2parallel
		Murata	GRM21BR61A476ME15	47 $\mu$ F/10V 2parallel
		Taiyo Yuden	MSASL21GBB5476MTNA01	47 $\mu$ F/10V 2parallel

- (\*1) Some ceramic capacitors have an effective capacitance that is significantly lower than the nominal value due to the applied DC bias and ambient temperature. For the input / output capacitance of this IC, use an appropriate ceramic capacitor according to the DC bias usage conditions (ambient temperature, input / output voltage) so that the effective capacitance value is equal to or higher than the recommended component.
- (\*2) If using a large-capacity capacitor such as an electrolytic capacitor or tantalum capacitor as the input capacitance, place a low ESR ceramic capacitor in parallel. If a ceramic capacitor is not placed, high-frequency voltage fluctuations will increase and the IC may malfunction.
- (\*3) If a large-capacity capacitor is used as output capacitor, the output stability may be reduced, and the ripple voltage may increase. Even if a large-capacity capacitor such as an electrolytic capacitor or tantalum capacitor is used as output capacitor, please place a low-ESR ceramic capacitor in parallel. Even if the capacitance is within the recommended range, the output stability may be reduced depending on the type and ESR etc. of the capacitor used, so please thoroughly test it on the actual equipment before use.

## ■ TYPICAL APPLICATION CIRCUIT / Parts Selection Method

### <Output voltage setting (V<sub>OUTSET</sub>)>

The output voltage can be set by adding an external dividing resistor.

The output voltage setting is determined by the equation below based on the values of R<sub>FB1</sub> and R<sub>FB2</sub>.

$$V_{OUTSET} = V_{FBE} \times (R_{FB1} + R_{FB2}) / R_{FB2}$$

$$R_{FB2} \leq 200k\Omega \text{ and } R_{FB1} + R_{FB2} \leq 1M\Omega$$

If the IC does not operate properly due to external noise, noise resistance performance can be improved by using a combination of R<sub>FB1</sub> and R<sub>FB2</sub> that is smaller than the above conditional expression.

### <C<sub>FB</sub> setting>

Adjust the value of the phase compensation speed-up capacitor C<sub>FB</sub> within ±20% using the equation as below.

$$C_{FB} = \frac{1}{2\pi \times f_{zfb} \times R_{FB1}}$$

$$f_{zfb} = \frac{1}{2\pi \sqrt{C_L \times L}}$$

### 【 Calculation Example 】

To set output voltage to 5.0V, (C<sub>L</sub>=22μF×3, L=4.7μH)

V<sub>OUTSET</sub> = 0.75V×(680kΩ+120kΩ)/120kΩ = 5.0V, and f<sub>zfb</sub> is set to a target of 9kHz using the above equation,

C<sub>FB</sub> = 1/(2×π×9kHz×680kΩ) = 26pF, A capacitor of E24 series is 27pF.

### 【Typical example】

V <sub>OUTSET</sub>	R <sub>FB1</sub>	R <sub>FB2</sub>	L	C <sub>L</sub>	C <sub>FB</sub>	f <sub>zfb</sub>
3.3V	510kΩ	150kΩ	4.7μH	10μF×2	18pF	16kHz
				22μF×3	36pF	9kHz
5.0V	680kΩ	120kΩ	4.7μH	10μF×2	14pF	16kHz
				22μF×3	27pF	9kHz

## ■ OPERATIONAL EXPLANATION

The XCL247/XCL248 series consists internally of a reference voltage supply with soft-start function, error amplifier, PWM comparator, ramp circuit, oscillator circuit, phase compensation (current feedback) circuit, current limit circuit, current limiting-PFM circuit, High-side driver FET, Low-side driver FET, buffer drive circuit, internal power supply (Local Reg) circuit, under voltage lockout (UVLO) circuit, gate clamp circuit, thermal shutdown circuit etc.

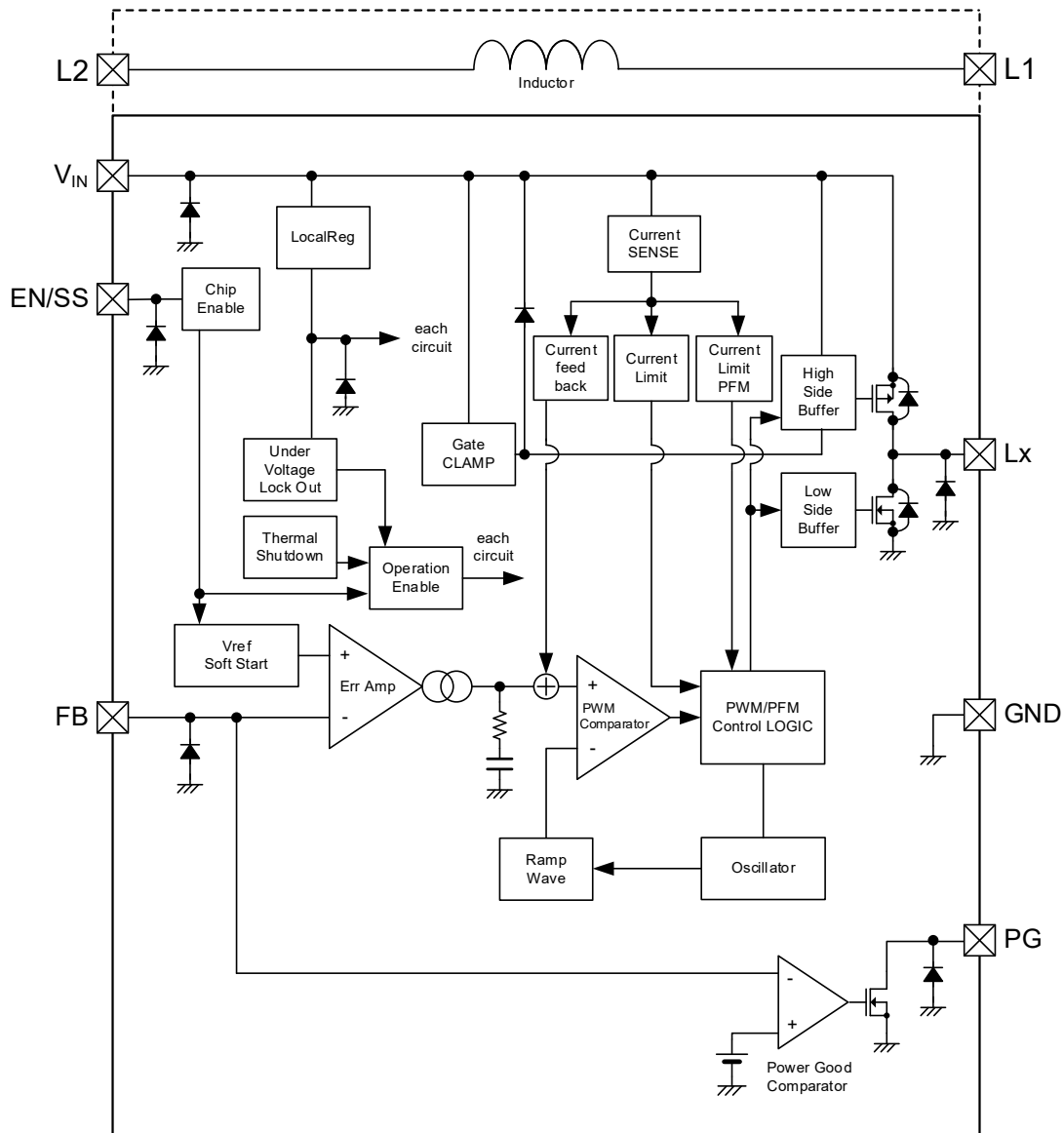

## OPERATIONAL EXPLANATION

### <Normal operation>

The reference voltage  $V_{ref}$  and FB pin voltage are compared using an error amplifier, the output from the error amplifier is phase compensated, and the signal is input to the PWM comparator to determine the ON time of switching during PWM operation.

The output signal from the error amplifier is compared to the ramp wave by the PWM comparator, and the output is sent to the buffer drive circuit and output from the Lx pin as the duty width of switching. This operation is performed continuously to stabilize the output voltage.

The current sense circuit monitors the driver FET current at each switching, and the output signal from the error amplifier is modulated as a multi-feedback signal (current feedback circuit). This achieves a stable feedback system to be obtained even when a low ESR capacitor such as a ceramic capacitor is used, and this stabilizes the output voltage.

### XCL247series : F-PWM control

XCL247 series operates at a constant frequency  $f_{osc}$  regardless of the output current, making it easy to filter switching noise.

Also, if the FB pin voltage remains higher than  $V_{FB}$ , the switching operation will be stopped (High side driver FET turned off, Low side driver FET turned on) until the FB pin voltage drops.

### XCL248series : PWM/PFM control

XCL248 series operates in PWM/PFM automatic switching mode.

PWM/PFM automatic switching control drops the switching frequency during light loads by turning on the High side driver FET when the coil current reaches the  $I_{PFM}$  (TYP. 300mA).

This operation reduces the loss during light loads and achieves high efficiency from light to heavy loads. As the output current increases, the switching frequency increases proportional to the output current, and when the switching frequency increases  $f_{osc}$ , the circuit switches from PFM control to PWM control and the switching frequency becomes fixed.

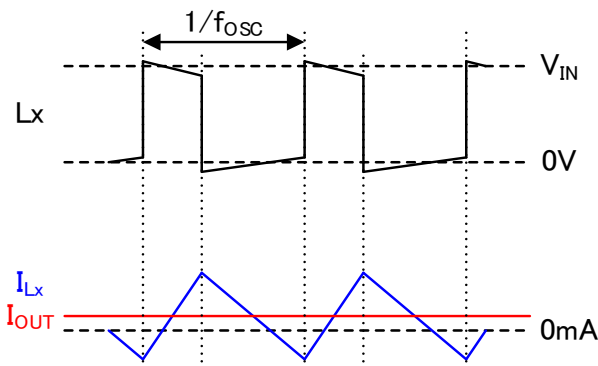

XCL247 Series (F-PWM control) : Example of light load operation

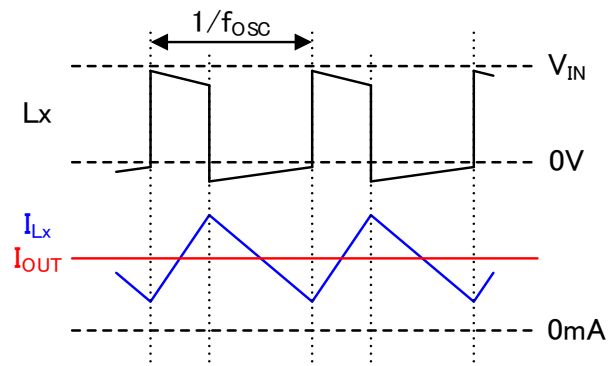

XCL247 Series (F-PWM control) : Example of heavy load operation

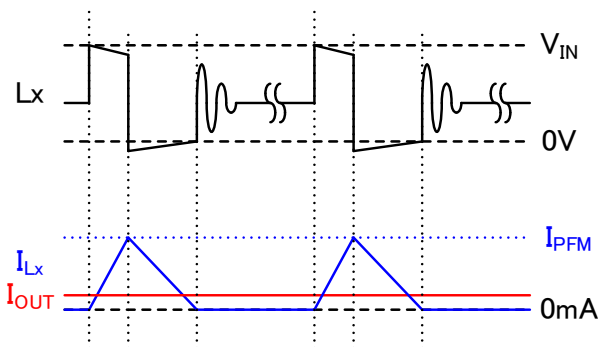

XCL248 Series (PWM/PFM control) : Example of light load operation

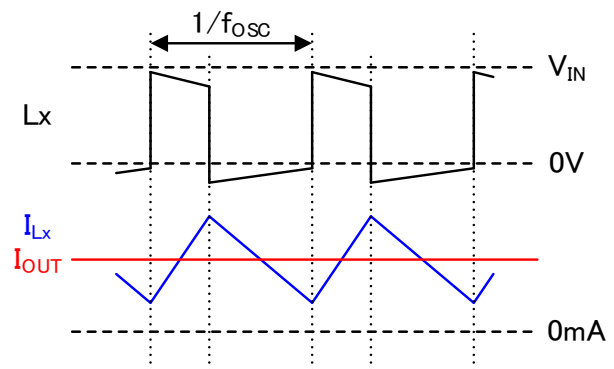

XCL248 Series (PWM/PFM control) : Example of heavy load operation

## OPERATIONAL EXPLANATION

### <EN Function / Start Mode·Soft-start Function>

The state of the IC can be switched by applying voltage to the EN/SS pin.

SIGNAL	STATUS
H	Active
L	Stand-by
OPEN	Stand-by

#### EN/SS="L" : Stand-by mode

When the "L" voltage is input to the EN/SS pin, the IC enters the stand-by mode, and the current consumption is reduced to the stand-by current  $I_{STB}$  (TYP. 0.6 $\mu$ A). In the stand-by mode, no signal is output to the Lx pin and the output voltage does not rise. In addition, various protection functions stop operating.

#### EN/SS="H" : Active mode

When the EN/SS pin voltage is "H", the IC becomes active. When the IC becomes active, it enters start-up mode and increases the output voltage to the set output voltage. In start-up mode, a soft-start function is provided to gently raise the output voltage to suppress inrush current at start-up. The soft-start time can be adjusted by externally mounting a capacitor and resistor on the EN/SS pin. During the start-up mode, the device operates in the same way as in normal operation, except that the reference voltage increases linearly.

##### (a) Internal soft-start time (without external RC)

When the EN/SS pin voltage rises steeply, the output voltage rises with an internally set soft-start time of  $t_{ss1}$  (TYP. 2.2ms) and shifts to normal mode.

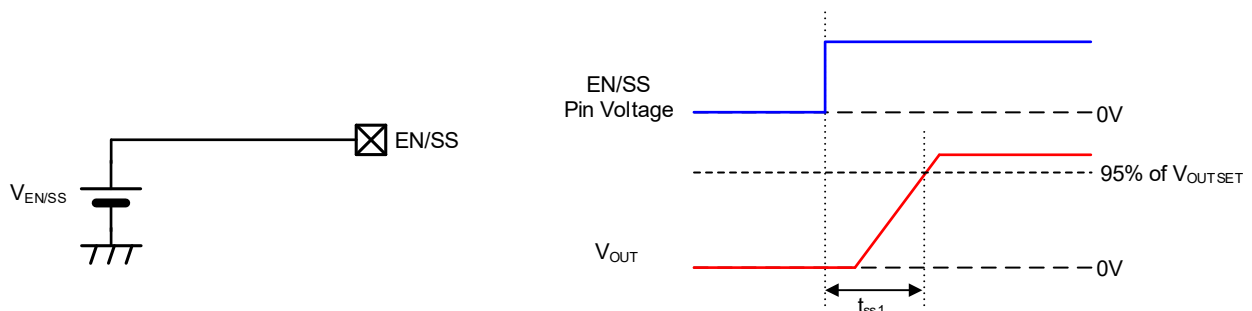

##### (b) Soft-start time external adjustment (with external RC)

The soft-start time can be adjusted by externally mounting a capacitor and resistor on the EN/SS pin. The externally set soft-start time ( $t_{ss2}$ ) is determined by the following formula, depending on the EN/SS pin voltage ( $V_{EN/SS}$ ),  $R_{SS}$ , and  $C_{SS}$  values.

$$t_{ss2} = C_{SS} \times R_{SS} \times \ln \frac{V_{EN/SS}}{V_{EN/SS} - 1.16V}$$

For example, When the soft-start time at  $C_{SS} = 0.47\mu F$ ,  $R_{SS} = 430k\Omega$ ,  $V_{EN/SS} = 12V$

$$t_{ss2} = 0.47 \times 10^{-6} \times 430 \times 10^3 \times \ln \frac{12}{12 - 1.16} = 21ms$$

However, it cannot start faster than the internally setting soft-start time  $t_{ss1}$ .

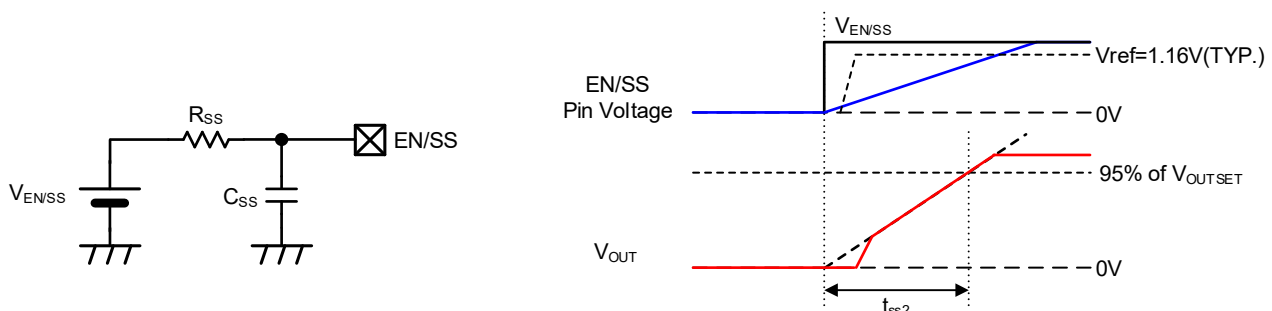

\* Definition of soft-start time : Time from  $V_{EN/SS}$  start-up until output voltage reaches 95% of set output voltage.

## OPERATIONAL EXPLANATION

### <Current Limit >

The current limit circuit of this IC detects the current flowing through the driver FET connected to Lx pin and equivalently monitors the coil current. The current limit function operates when over current is detected. When the current limit function operates, the High side current limit function and Low side current limit function operate.

The current limit state continues until the overcurrent state is released, and the output voltage automatically recovers when the overcurrent state is released.

A current fold-back circuit is used for the current limit function.

The current foldback circuit reduces the current limit when the output voltage drops. This operation reduces the output current when the output voltage drops.

### High side Current Limit

The High side current limit function detects when the coil current exceeds the High side current limit value  $I_{LIMH}$  (TYP. 1.4A) and turns off the High side driver FET. In other words, it controls the coil current so that it does not exceed a certain peak value. However, if the input voltage is high, the coil current peak value may exceed  $I_{LIMH}$  due to the operation delay of the internal circuit.

### Low side Current Limit

The Low side current limit function turns on the Low side driver FET until the coil current becomes less than the Low side current limit value  $I_{LIML}$  (TYP. 1.0A). In other words, it controls the coil current to stay below a certain coil current bottom value.

The current limit function also operates during start-up mode.

During start-up mode, the output voltage is lower than the set output voltage, the current limit value is reduced, which speeds up overcurrent detection.

If an output capacitance with a higher effective capacitance value than the recommended component is used, the start-up will take place while the current limit function is operating, and the start-up time may be much longer than the soft-start time.

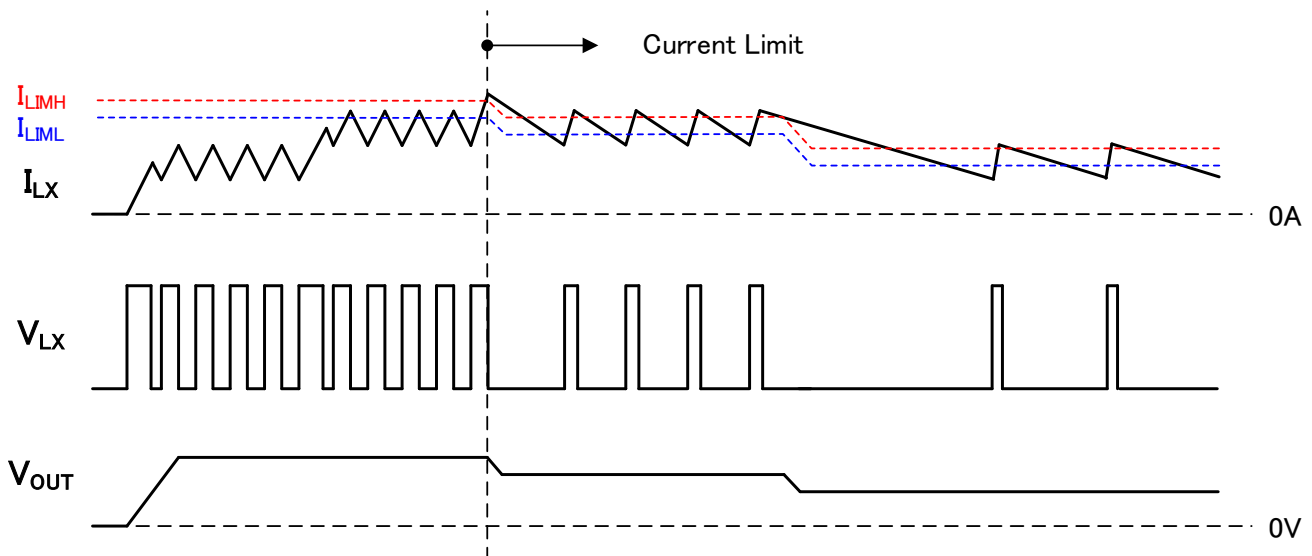

## ■ OPERATIONAL EXPLANATION

### <Thermal Shutdown >

The junction temperature is monitored to protect the IC from thermal destruction.

When the junction temperature reaches the thermal shutdown detection temperature  $T_{TSD}$  (TYP. 160°C), the thermal shutdown activated, the High side driver FET and Low side driver FET are turned off. When the junction temperature drops to the thermal shutdown release temperature  $T_{TSD}-T_{HYS}$  (TYP. 135°C) by stopping the current supply, the output voltage is turned on by the start-up mode, and then normal operation starts.

### <UVLO>

This function monitors the internal power supply of the IC and prevents false pulse output from the Lx pin due to unstable operation when the internal power supply is low. As the IC's internal power supply drops as the  $V_{IN}$  pin voltage drops, the UVLO function operates.

When the  $V_{IN}$  pin voltage falls below  $V_{UVLOD}$  (TYP. 2.7V), the UVLO function operates, and forcibly turns off the driver FETs.

When the  $V_{IN}$  pin voltage rises above  $V_{UVLOR}$  (TYP. 2.8V), the UVLO function is released, and the output voltage rises according to the start-up mode.

Moreover, during the UVLO operation, the internal circuit is operating because stopping by UVLO is not same to a stand-by mode and just switching operation is stopped.

### <Negative Current Limit >

When the output voltage becomes higher than the set voltage, the Low side driver FET turns on to reduce the output voltage. If the Low side driver FET continues to be turned on, the coil current reverses and a negative current continues to flow. This reverse current is limited to -900mA (TYP.) by the negative current limit function.

When the negative current limit function operates, the Low side driver FET turns off and remains until the next cycle. During this period, the reverse current flows through the parasitic diode of the High side driver FET into the power supply connected to the  $V_{IN}$  pin.

If the negative current limit function operates during start-up mode, the switching operation stops until the reference voltage becomes higher than the FB voltage.

### <Over Voltage Protection >

An output overvoltage protection function is built in to suppress output voltage overshoot after startup is complete or after load transient response. When the FB pin voltage reaches  $V_{OVP}$  (TYP. 0.81V) or higher, the output overvoltage protection function operates and forcibly turns off the High side driver FET.

In F-PWM control (XCL247), the Low side driver FET turns on immediately after the output overvoltage protection function operates and remains in that state until the next cycle.

In PWM/PFM automatic switching control (XCL248), the output overvoltage protection function turns off the driver FET. When the output voltage drops to the set value due to the output current switching operation resumes.

### <Power Good >

The power good function allows monitoring the output status and IC status.

CONDITIONS		SIGNAL
EN/SS = H	$V_{FB} > V_{PGDET}$	H (High impedance)
	$V_{FB} \leq V_{PGDET}$	L (Low impedance)
	Thermal Shutdown	L (Low impedance)
	UVLO ( $V_{IN} < V_{UVLOD}$ )	Undefined State
EN/SS = L	Stand-by	L (Low impedance)

The PG pin is an Nch open drain output, therefore a pull-up resistance (approx. 100kΩ) must be connected to the PG pin. When the power good function is not used, connect the PG pin to GND or leave it open.

A delay time of 400μs(TYP.) is provided from the moment, the FB pin voltage drops below  $V_{PGDET}$  to PG="L".

If the FB pin voltage returns to a voltage higher than  $V_{PGDET}$  during the delay time, PG remains "H".

This prevents PG="L" due to output undershoot during transient response.

In addition, there is no intentional delay for PG="L" due to the operation of the protection function or transition to the stand-by state.

## NOTES ON USE

- 1) For the phenomenon of temporal and transitional voltage decrease or voltage increase, the IC may be damaged or deteriorated if IC is used beyond the absolute MAX. specifications. Also, if used under out of the recommended operating range, the IC may not operate normally or may cause deterioration.

If a voltage exceeding the absolute maximum voltage is applied to the IC due to chattering caused by a mechanical switch or an external surge voltage, please use a protection circuit as a countermeasure. Please see the countermeasures from (a) to (d) shown below.

- (a) When voltage exceeding the absolute maximum ratings comes into the  $V_{IN}$  pin due to the transient change on the power line, there is a possibility that the IC breaks down in the end. To prevent such a failure, please add a TVS between  $V_{IN}$  and GND as a countermeasure.
- (b) When the input voltage decreases below the output voltage, there is a possibility that an overcurrent will flow in the IC's internal parasitic diode and exceed the absolute maximum rating of the Lx pin.  
If the current is pulled into the input side by the low impedance between  $V_{in}$  and GND, then please add an SBD between  $V_{OUT}$  and  $V_{IN}$  as a countermeasure.
- (c) When a negative voltage is applied to the input voltage by a reverse connection or chattering, an overcurrent could flow in the IC's parasitic diode and damage the IC. Please add a reverse touching protection diode as a countermeasure.
- (d) When a sudden surge of electrical current travels along the  $V_{OUT}$  pin and GND due to a short-circuit, electrical resonance of circuit involving parasitic inductor of cable related to short circuit. An output capacitor ( $C_L$ ) and impedance such as  $V_{OUT}$  line generates a negative voltage exceeding the breakdown voltage and may damage the device. Please take measures such as adding an SBD between  $V_{OUT}$  and GND.

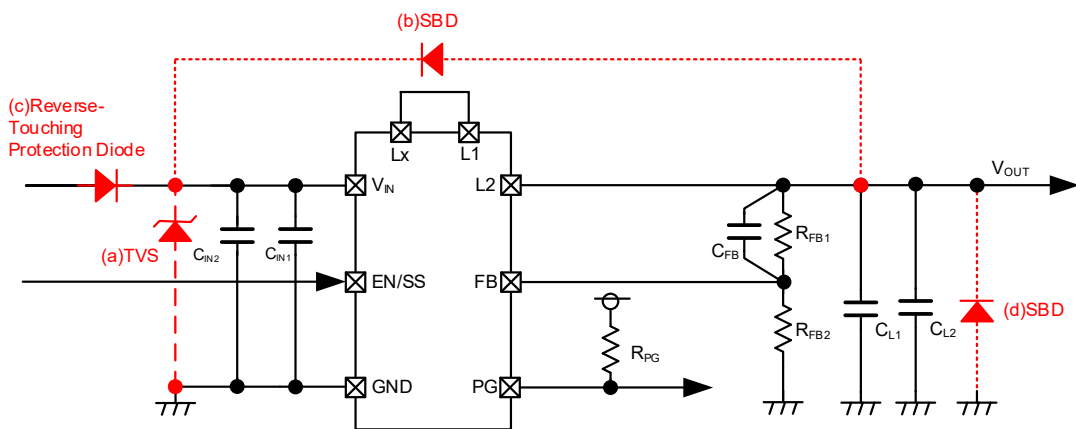

- 2) Switching regulators such as DC/DC converters generate spike noise and ripple voltage. The DC/DC converter characteristics depend greatly on the externally connected components such as coil inductance value, capacitor, board layout of peripheral components. Please refer to the specifications and standard circuit examples of each component when carefully considering which components to select.

## ■ NOTES ON USE

### 3) Stable Operating Range

The recommended operating range of this IC can operate normally varies depending on the product number. Please confirm that the power supply specifications you are using are within the recommended operating range before use.

#### $V_{OUTSET}-V_{IN}$ Stable operating range

##### XCL247 (F-PWM control)

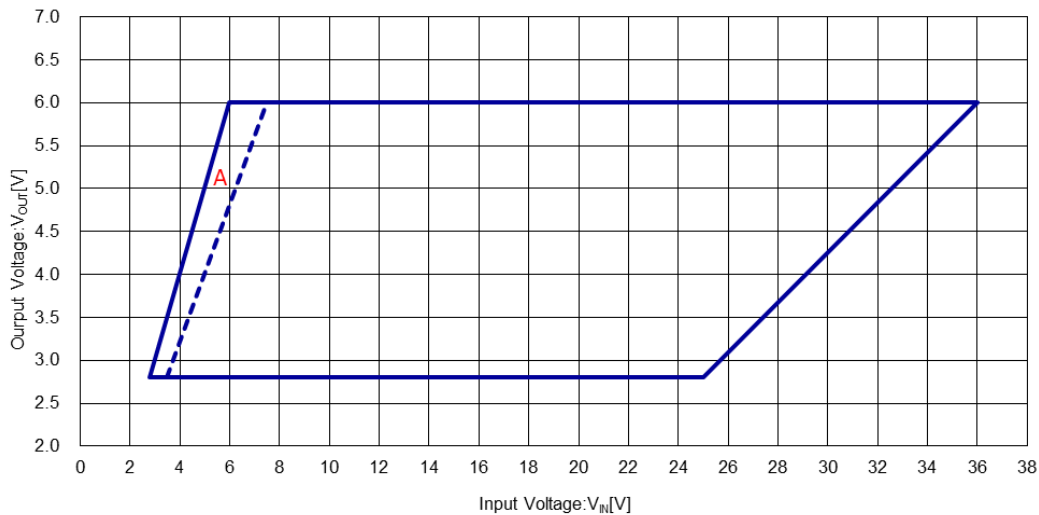

##### XCL248 (PWM/PFM control)

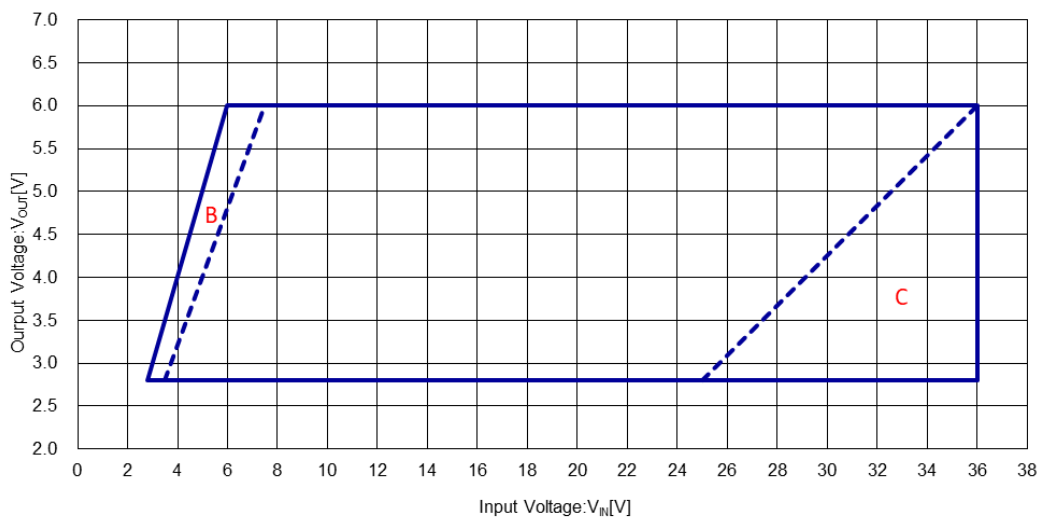

#### 【Within stable operating range】

Please note the following points when using in areas A to C within the stable operating range.

- (A) The switching frequency may drop or the  $V_{OUT}$  ripple voltage may increase near the switch to 100% Duty cycle.
- (B) The coil current may reverse, and the efficiency may drop significantly due to F-PWM operation instead of PFM operation at light loads. In addition, the switching frequency may drop and the  $V_{OUT}$  ripple voltage may increase near the switch to 100% Duty cycle.
- (C) Due to the Minimum On-time, the Lx oscillation may become unstable and the  $V_{OUT}$  ripple voltage may increase, or the IC may not switch to PWM operation up to the maximum output current.

#### 【Outside stable operating range】

If the IC is used over the stable operating range, the following operations may occur, and the IC may not operate normally.

- (a) When the step-down ratio is high, the Min On Time may cause the Lx oscillation to become unstable or pulse skipping may occur, resulting in large ripple voltage.
- (b) When the step-down ratio is low, the IC operates at the Maximum Duty Cycle and the output voltage may drop below the set output voltage.

## ■ NOTES ON USE

- 4) The ripple voltage could be increased when switching from discontinuous conduction mode to continuous conduction mode and when switching to 100% Duty cycle.
- 5) When using an external soft start using the EN/SS pin, if the EN/SS pin is at an intermediate voltage when powering on, etc., the external soft start may not work and an increase in inrush current may result.
- 6) The output overvoltage protection function suppresses output voltage overshoot, but at the same time, it also suppresses the operation of the error amplifier.  
As a result, the output overvoltage protection function and the error amplifier may interact with each other, causing the output voltage to become unstable. If the output overvoltage protection function is activated due to a sudden load change, etc., and the output voltage becomes unstable, take measures such as increasing the output capacity.
- 7) Torex places an importance on improving our products and their reliability. We request that users incorporate fail safe designs and post aging protection treatment when using Torex products in their systems.
- 8) This IC is an Inductor Built-in product, do not place it in an environment with a strong magnetic field such as near a magnet. The influence of a strong magnetic field may cause a decrease in inductance value, deterioration of efficiency, and abnormal operation of the IC.
- 9) The internal coil is for this product only. Do not use it for any purpose other than this product.

## ■ NOTES ON USE

10) Instructions of pattern layouts.

Especially noted in the pattern layout are as follows.

Please refer to the reference pattern layout on the following.

(a) Wire the large current line using thick, short connecting traces.

This makes it possible to reduce the wire impedance, which is expected to reduce noise and improve heat dissipation.

If the wire impedance of the large current line is large, it may cause noise or the IC to not operate normally.

Especially when the noise is large, the current limit function and the integral latch function may not work.

(b) Place the input capacitance  $C_{IN}$ , output capacitance  $C_L$ , IC which the large current flows on the same surface.

If they are placed on both sides, a large current will flow through Via, which has high impedance, it may cause noise and the IC may not operate normally.

(c) Please mount each external component as close to the IC as possible.

Especially place the output capacitance  $C_L$  near the IC and connect it with as low impedance as possible.

If the output capacity  $C_L$  and IC are too far apart, it may cause noise, or the IC may not operate normally.

(d) The FB line connected to the FB pin is extremely sensitive to noise, so connect it with the shortest possible wire. If the FB line is long, the IC may not operate normally due to switching noise and external noise.

If the IC does not operate normally due to external noise, etc., please review the board layout or adjust the value of FB resistance to low.

If the FB resistance value is lowered, the efficiency during PFM operation may decrease. Please use it after confirming it with the actual machine.

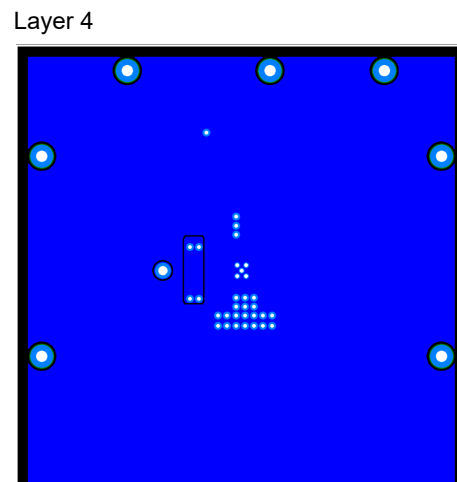
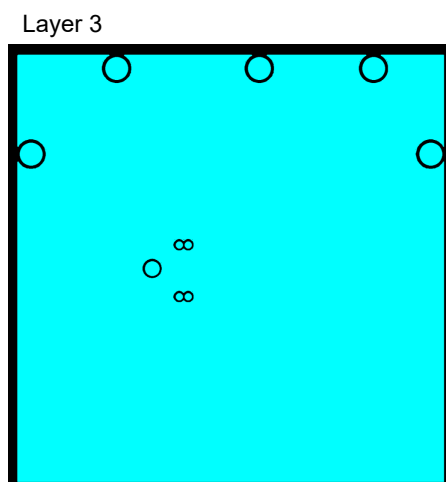
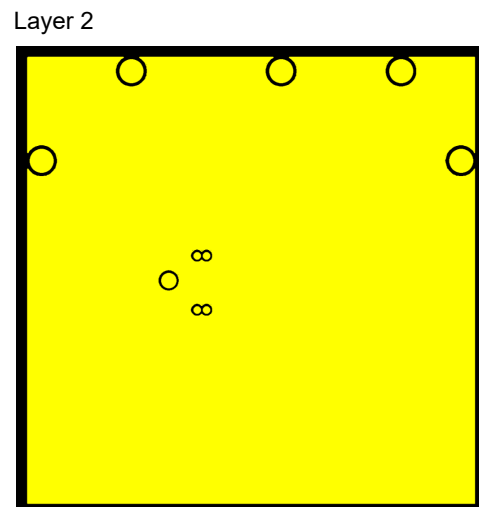
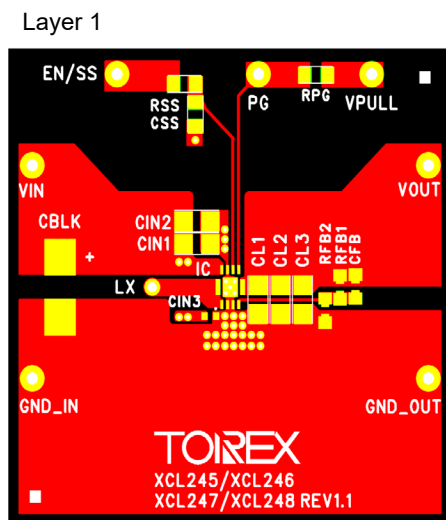

## ■ Notes on handling of product

- (1) The coil mounted on this product complies with the general surface mount type chip inductor specifications, and may have scratches, flux stains, etc.
- (2) Do not use this product in the following environments. Places exposed to water or salt water, places where condensation occurs, places where toxic gases (hydrogen sulfide, zinc acid, chlorine, ammonia, etc.) are present.
- (3) Please do not wash this product with solvent.

## ■ ABOUT IMPLEMENTATION

- (1) This product is only suitable for reflow soldering (it is not suitable for flow soldering).
- (2) This product uses solder to mount the coil on top of the package. This is no problem for regular circuit board mounted reflow, but if excessive impact is applied during reflow, the mounted coil could be moved out of position or the coil could fall off. Be careful not to strike the circuit board during circuit board mounting reflow.

## ■ TYPICAL PERFORMANCE CHARACTERISTICS

PRODUCTS	CONDITIONS	C <sub>IN</sub>	C <sub>L</sub>
XCL247B0K1 XCL248B0K1 (f <sub>osc</sub> =1.2MHz)	V <sub>IN</sub> =12V, V <sub>OUT</sub> =3.3V	2.2μF (C2012X7R1H225K125AC)	47μF×2 (MSASL21GBB5476MTNA01)
	V <sub>IN</sub> =12V, V <sub>OUT</sub> =5.0V	2.2μF (C2012X7R1H225K125AC)	47μF×2 (MSASL21GBB5476MTNA01)
	V <sub>IN</sub> =24V, V <sub>OUT</sub> =3.3V	2.2μF (C2012X7R1H225K125AC)	47μF×2 (MSASL21GBB5476MTNA01)
	V <sub>IN</sub> =24V, V <sub>OUT</sub> =5.0V	2.2μF (C2012X7R1H225K125AC)	47μF×2 (MSASL21GBB5476MTNA01)

## TYPICAL PERFORMANCE CHARACTERISTICS

(1) Efficiency vs. Output current

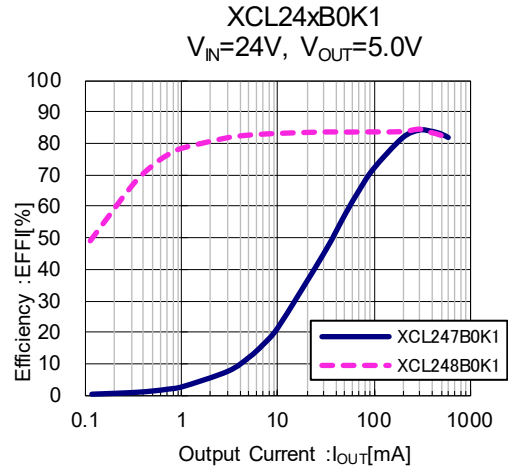
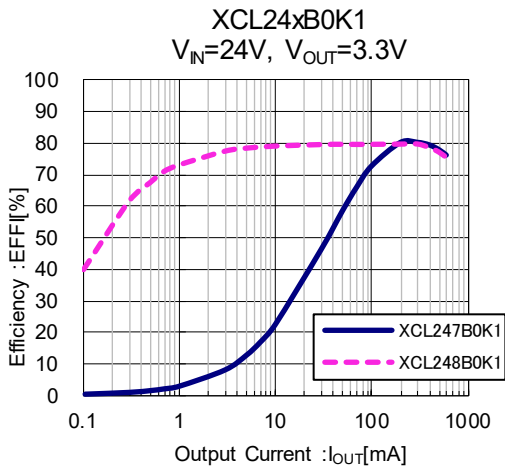
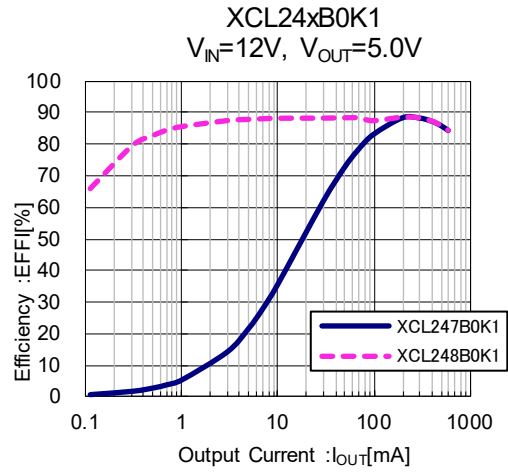
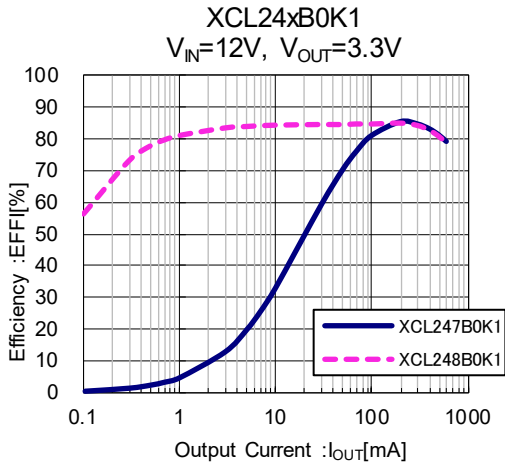

## ■ TYPICAL PERFORMANCE CHARACTERISTICS

### (2) Output Voltage vs. Output Current

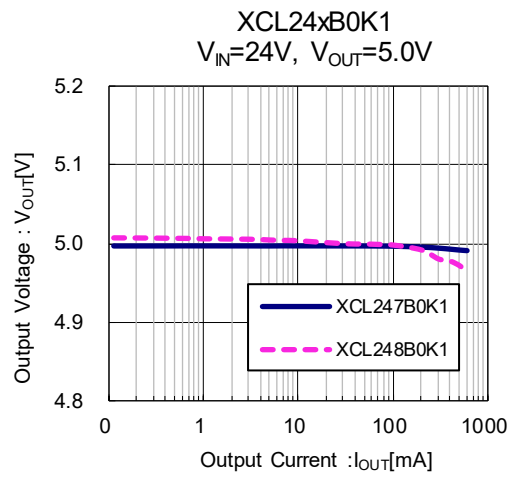
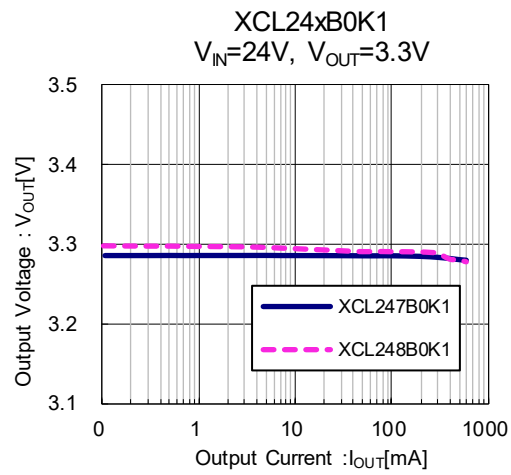
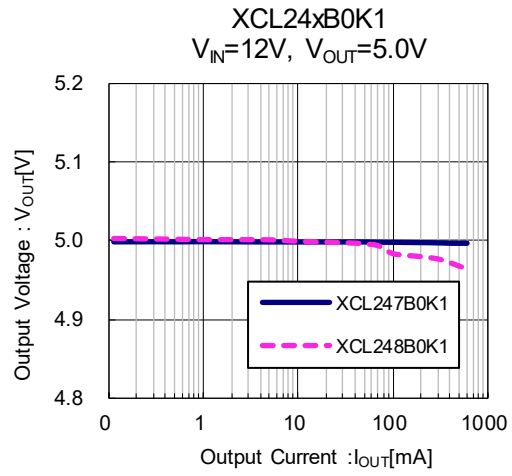
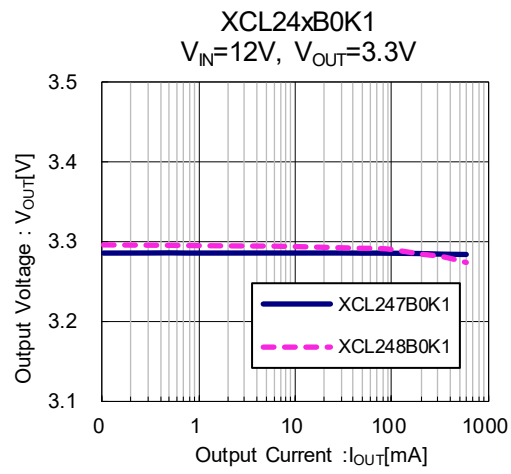

## TYPICAL PERFORMANCE CHARACTERISTICS

### (3) Ripple Voltage vs. Output Current

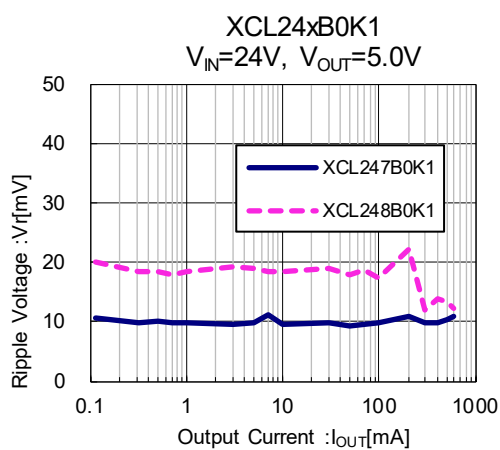
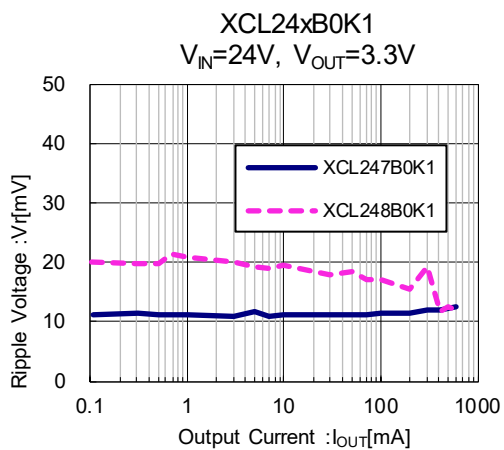
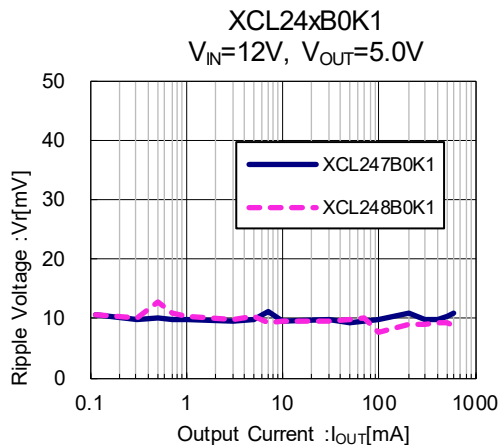
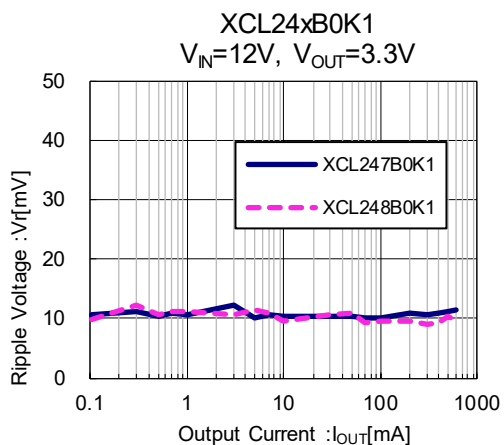

## TYPICAL PERFORMANCE CHARACTERISTICS

(4) FB Voltage vs. Ambient Temperature

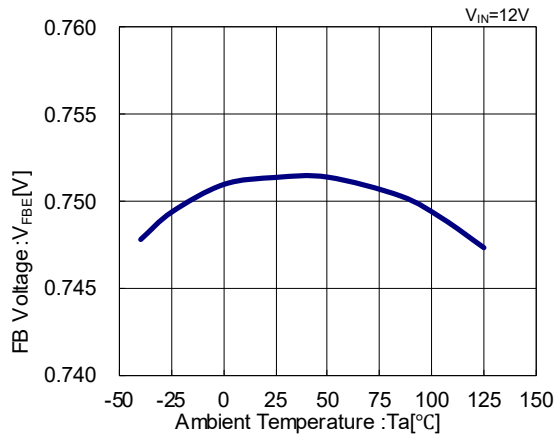

(5) UVLO Voltage vs. Ambient Temperature

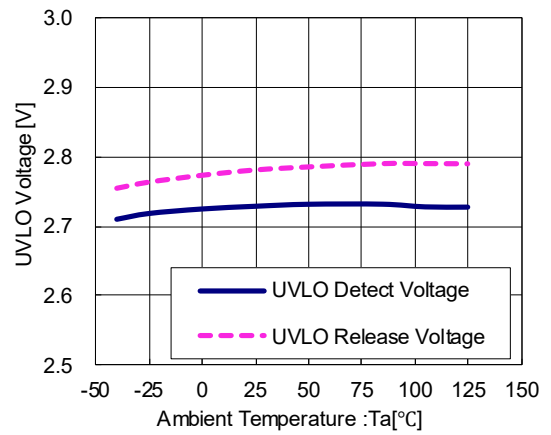

(6) Oscillation Frequency vs. Ambient Temperature

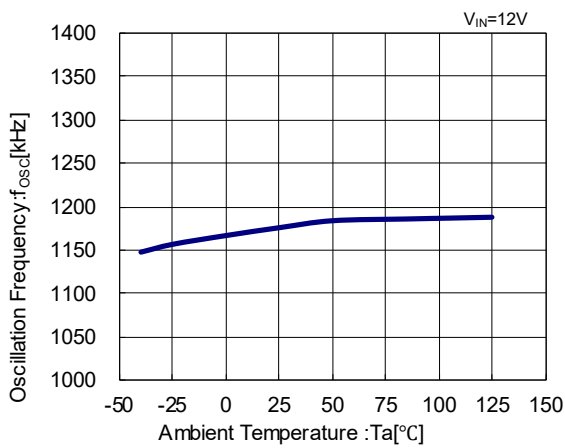

(7) Stand-by Current vs. Ambient Temperature

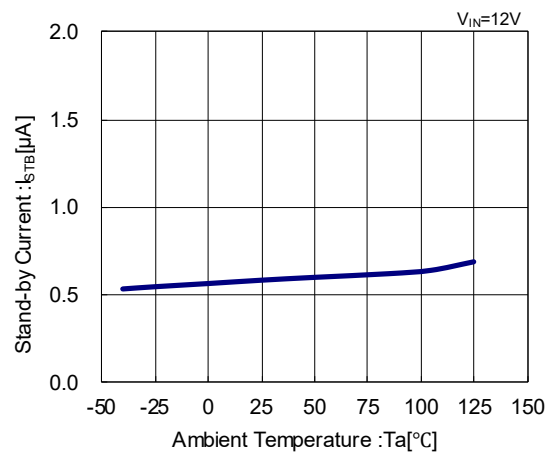

(8) Lx SW On Resistance vs. Ambient Temperature

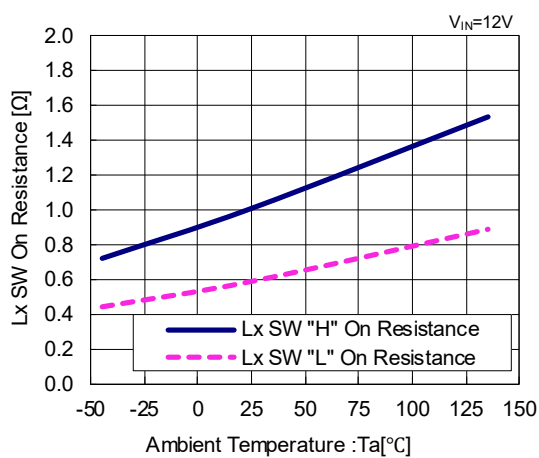

## TYPICAL PERFORMANCE CHARACTERISTICS

(9) Quiescent Current vs. Ambient Temperature

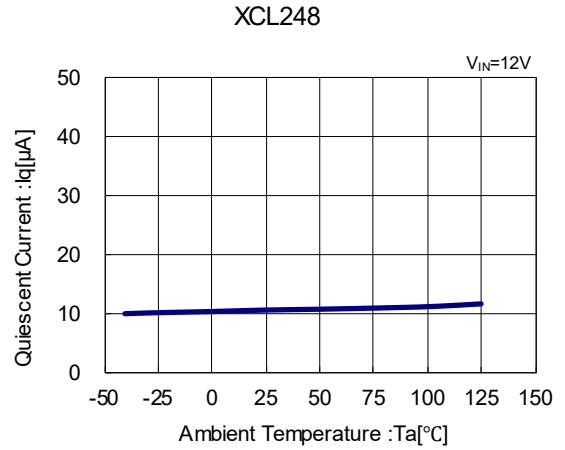
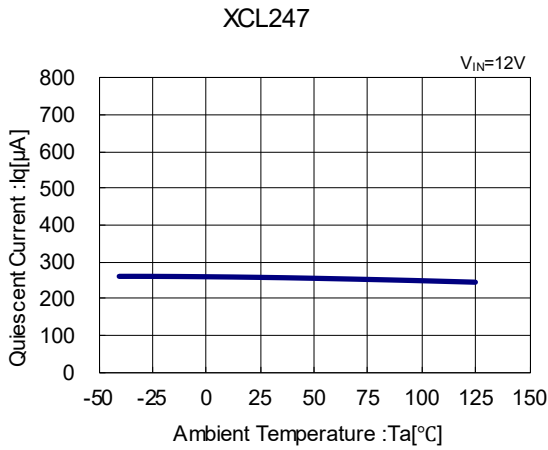

(10) Internal Soft-Start Time vs. Ambient Temperature

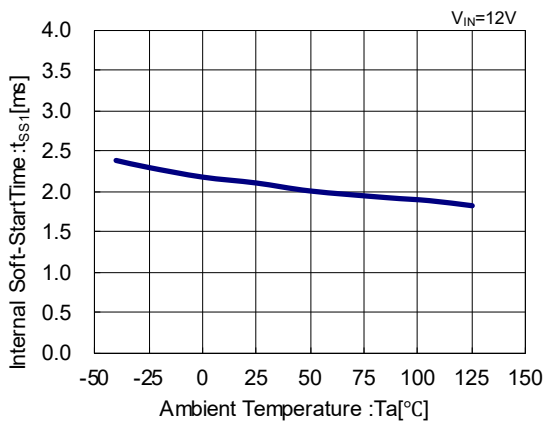

(11) External Soft-Start Time vs. Ambient Temperature

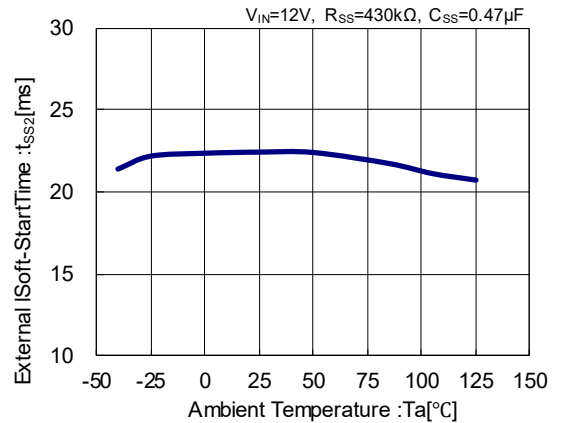

(12) EN/SS Voltage vs. Ambient Temperature

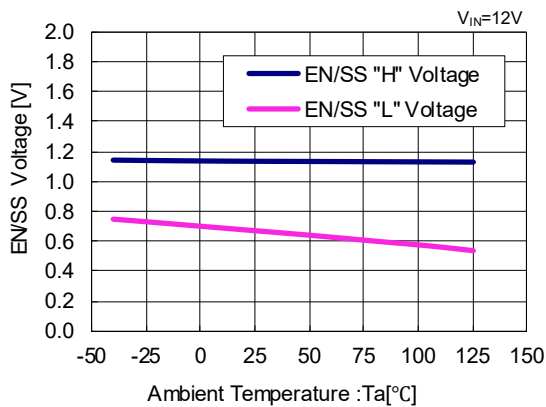

(13) Output Current Operation Area

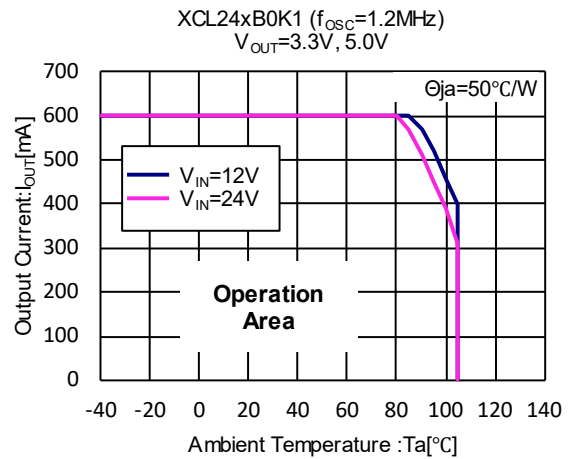

## TYPICAL PERFORMANCE CHARACTERISTICS

(14) PG Detect Voltage vs. Ambient Temperature

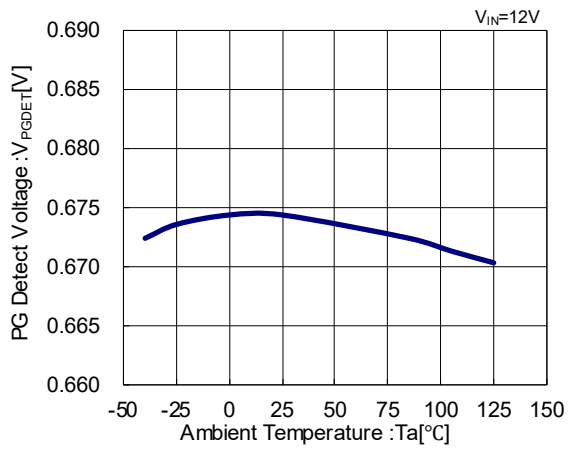

(15) PG Output Voltage vs. Ambient Temperature

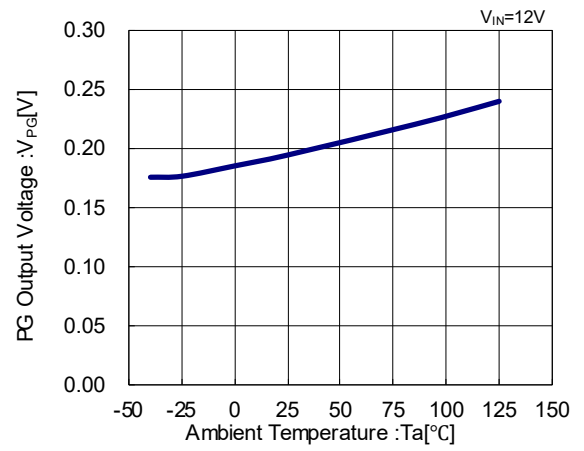

(16) Coil Direct Current Resistance vs. Ambient Temperature

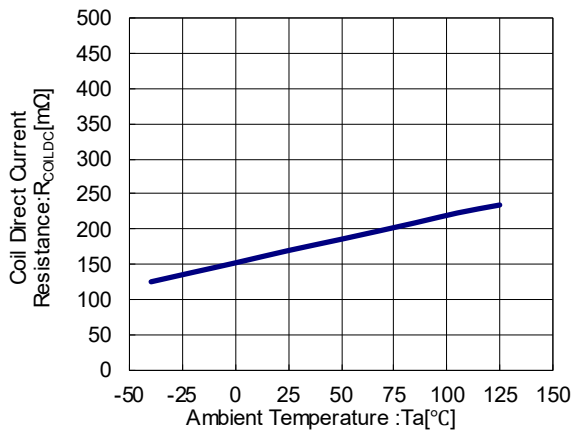

## TYPICAL PERFORMANCE CHARACTERISTICS

### (17) Load Transient Response

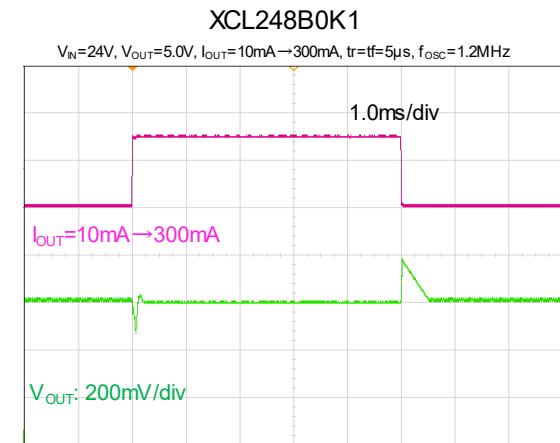
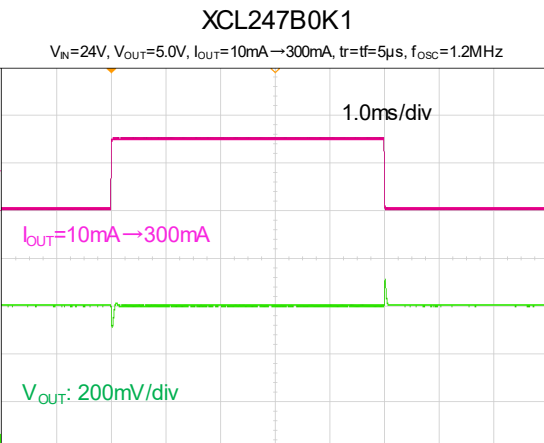
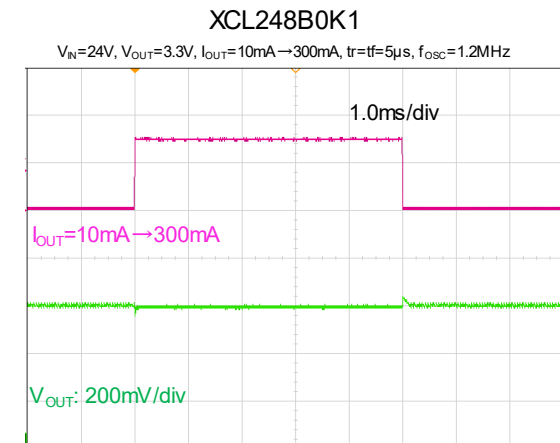
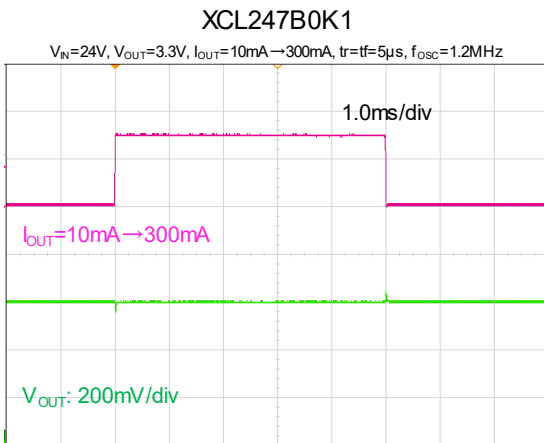
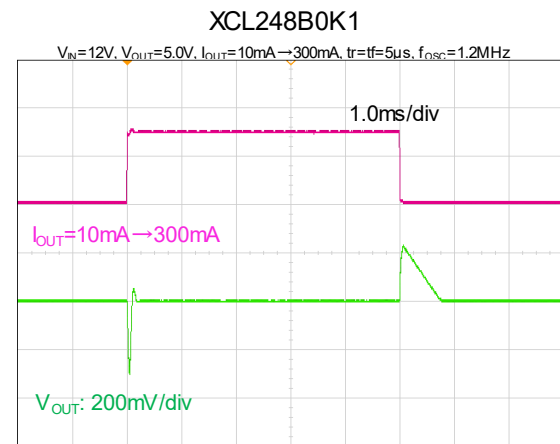
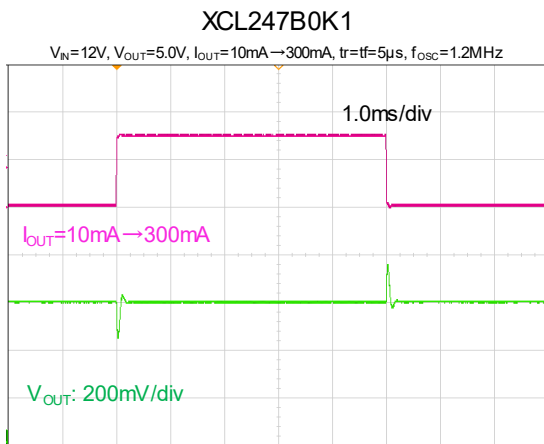
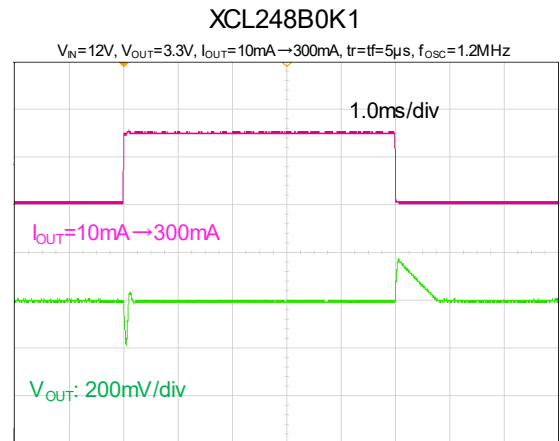
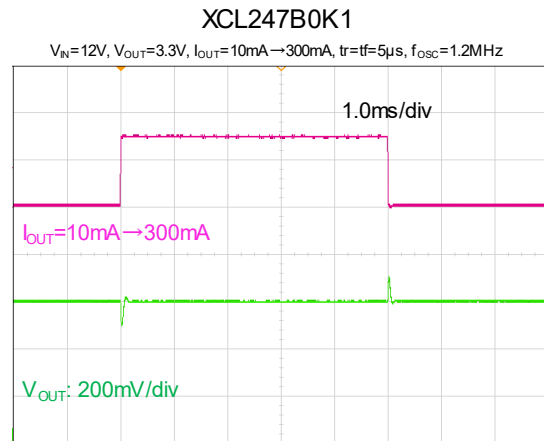

## ■ TYPICAL PERFORMANCE CHARACTERISTICS

### (18) Input Transient Response

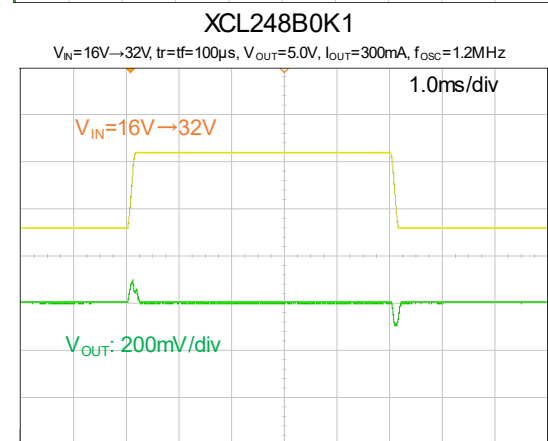
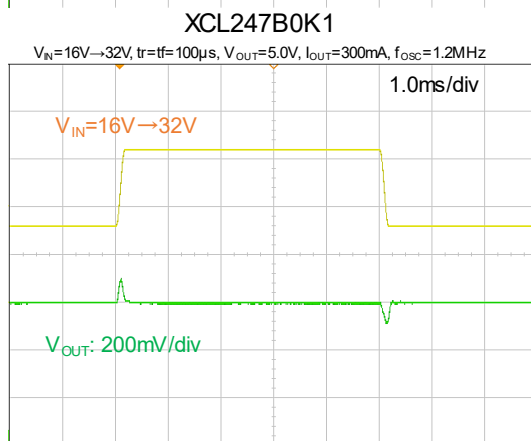
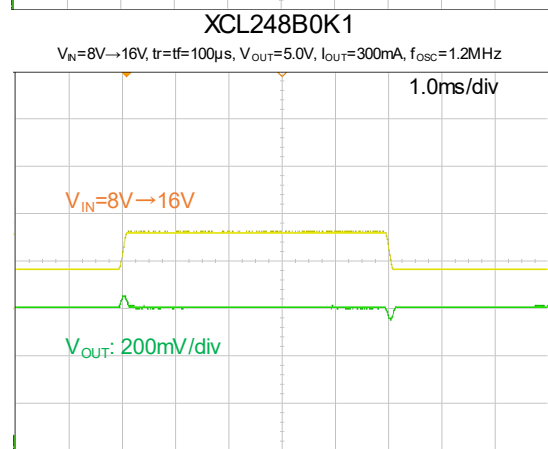
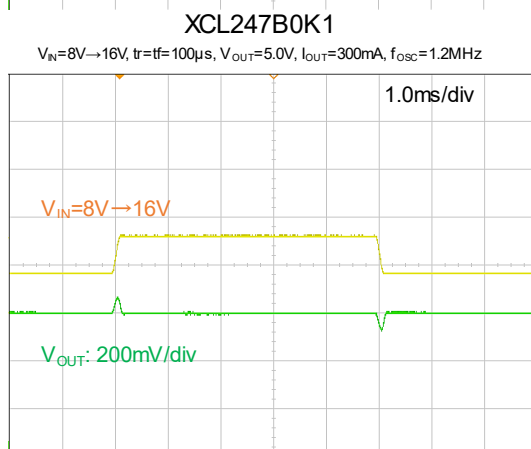
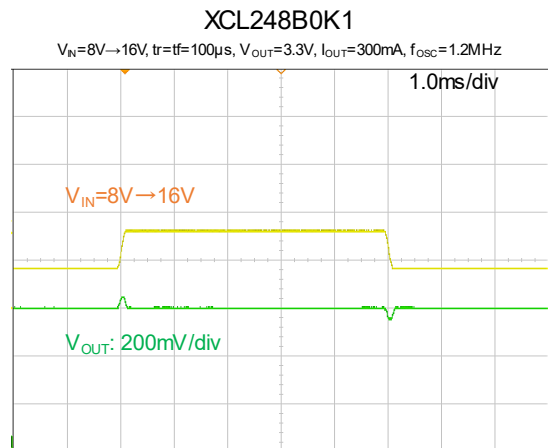
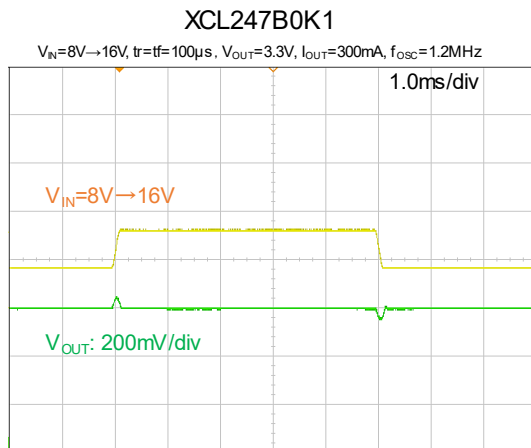

## TYPICAL PERFORMANCE CHARACTERISTICS

(19) Start-up Waveform (EN/SS Rising)

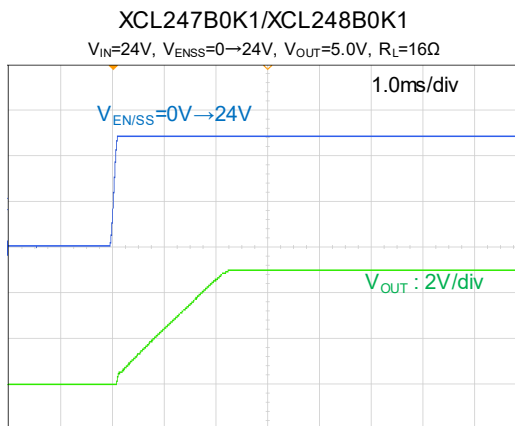
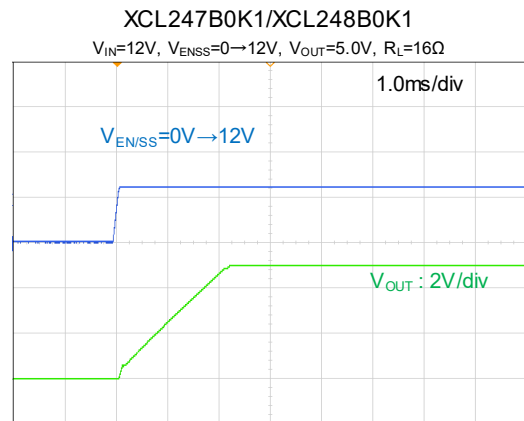
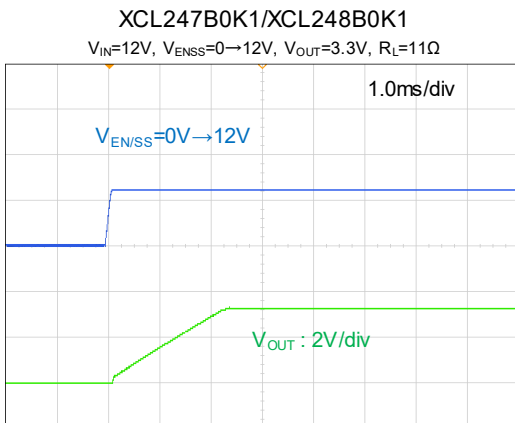

(20) Start-up Waveform ( $V_{IN}$  Rising)

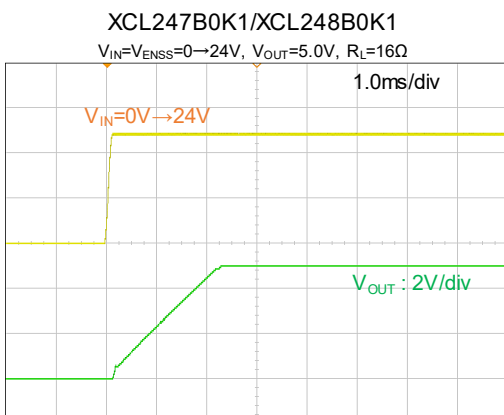
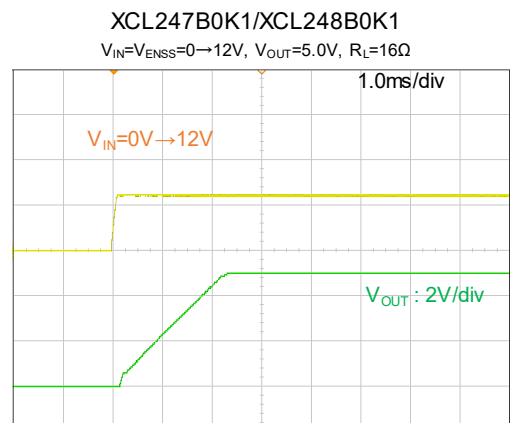
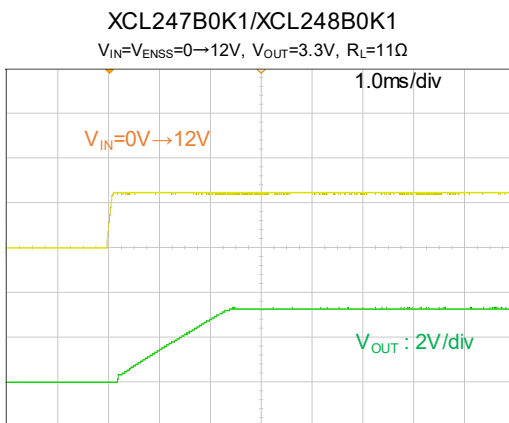

## ■ PACKAGING INFORMATION

For the latest package information go to, [www.torex.co.jp/technical-support/packages/](http://www.torex.co.jp/technical-support/packages/)

PACKAGE	OUTLINE / LAND PATTERN	THERMAL CHARACTERISTICS
DFN3030-10B	<a href="#">DFN3030-10B PKG</a>	<a href="#">DFN3030-10B Power Dissipation</a>

## MARKING RULE

①② represents products series

MARK		SERIES	Type	PRODUCT SERIES
①	②			
T	P	XCL247	B	XCL247B0K1H2-G
T	R	XCL248	B	XCL248B0K1H2-G

③④ represents production lot number

01~09, 0A~0Z, 11~9Z, A1~A9, AA~AZ, B1~ZZ in order. (G, I, J, O, Q, W excluded)

\* No character inversion used.

DFN3030-10B

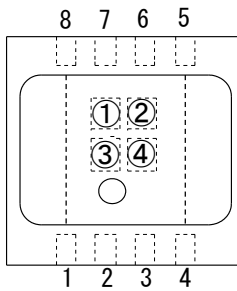

1. The product and product specifications contained herein are subject to change without notice to improve performance characteristics. Consult us, or our representatives before use, to confirm that the information in this datasheet is up to date.
2. The information in this datasheet is intended to illustrate the operation and characteristics of our products. We neither make warranties or representations with respect to the accuracy or completeness of the information contained in this datasheet nor grant any license to any intellectual property rights of ours or any third party concerning with the information in this datasheet.
3. Applicable export control laws and regulations should be complied and the procedures required by such laws and regulations should also be followed, when the product or any information contained in this datasheet is exported.
4. The product is neither intended nor warranted for use in equipment of systems which require extremely high levels of quality and/or reliability and/or a malfunction or failure which may cause loss of human life, bodily injury, serious property damage including but not limited to devices or equipment used in 1) nuclear facilities, 2) aerospace industry, 3) medical facilities, 4) automobile industry and other transportation industry and 5) safety devices and safety equipment to control combustions and explosions. Do not use the product for the above use unless agreed by us in writing in advance.
5. Although we make continuous efforts to improve the quality and reliability of our products; nevertheless Semiconductors are likely to fail with a certain probability. So in order to prevent personal injury and/or property damage resulting from such failure, customers are required to incorporate adequate safety measures in their designs, such as system fail safes, redundancy and fire prevention features.
6. Our products are not designed to be Radiation-resistant.
7. Please use the product listed in this datasheet within the specified ranges.
8. We assume no responsibility for damage or loss due to abnormal use.
9. All rights reserved. No part of this datasheet may be copied or reproduced unless agreed by Torex Semiconductor Ltd in writing in advance.

TOREX SEMICONDUCTOR LTD.