



深圳市一众显示科技有限公司

SHEN ZHEN TEAM SOURCE DISPLAY TECH. CO, TD.

TFT-LCD Module Specification

Module NO.: TST421GGU-01C

Version: V1.0

APPROVAL FOR SPECIFICATION

APPROVAL FOR SAMPLE

For Customer' s Acceptance:	
Approved by	Comment

Team Source Display:		
Presented by	Reviewed by	Organized by

Version No.	Date	Content	Remark
V1.0	2018-9-18	Initial Release	

3. GENERAL SPECIFICATIONS

Composition: 4.21 inch WVGA resolution display with a projected Capacitive Touch Panel (CTP)
 Interface: RGB interface for LCM and I²C for CTP.

Parameter	Specifications	Unit
Screen Size	4.21 (Diameter)	inch
Display Format	720 x (R,G,B) x 720	dot
LCD Active Area	105.84(H) 105.84(V)	mm
Sensor Active Area	108.24(H) x 108.24(V)	
Pixel Pitch	0.147(H) x 0.147(V)	mm
Pixel Configuration	Stripe	
Outline Dimension	132.5(H) x 132.5(V) x 9.3(D)	mm
Back-light	LED	
TFT-LCD Display mode	Normal Black	
Weight	TBD	g
View Angle direction(TFT)	All	
Our components and processes are compliant to RoHS & REACH standard		

4. LCD ABSOLUTE MAXIMUM RATINGS

Ta=25°C

Parameter	Symbol	Min.	Max.	Unit	Remark
Power supply voltage	VDD	-0.3	3.96	V	
Operating temperature	Top	-30	85	°C	
Storage temperature	Tst	-30	85	°C	

5. LCD ELECTRICAL CHARACTERISTICS

5.1 Typical operation conditions

GND=0V, Ta=25°C

Parameter	Symbol	Min.	Typ.	Max.	Unit	Remark
Power Supply voltage	VDD	2.7	-	3.6	V	
“H” level logical input voltage	V _{IH}	0.7VDD	-	VDD+0.3	V	
“L” level logical input voltage	V _{IL}	-0.3	-	0.3VDD	V	

5.2 Backlight Driving Consumption

Ta= 25°C

Parameter	Symbol	Min.	Typ.	Max.	Unit	Remark
LED voltage	V _F	-	-	21	V	
LED current	I _F	-	130	-	mA	
LED dice Life Time		-	50,000	-	hr	

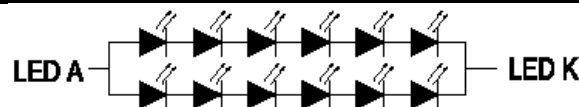

V_F : 21V Max.
 I_F : 130mA

6. LCD INPUT SIGNAL TIMING

6.1 SPI normal write / read mode

6.1.1 SPI normal write mode

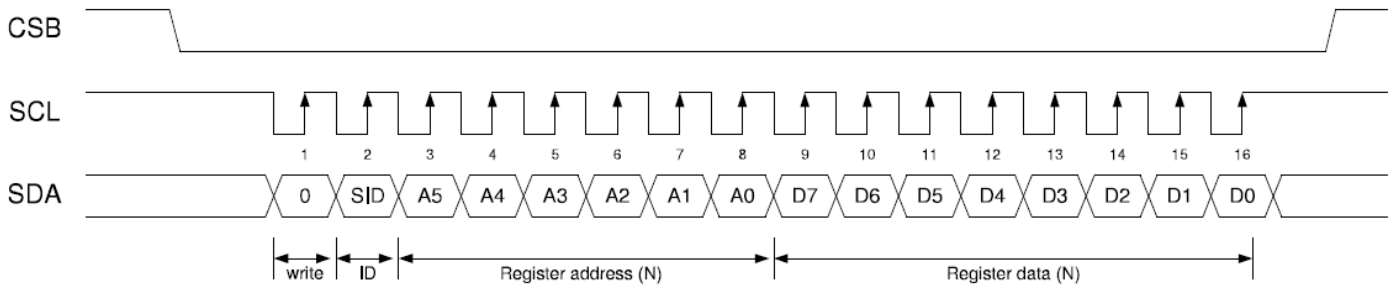

6.1.2 SPI normal read mode

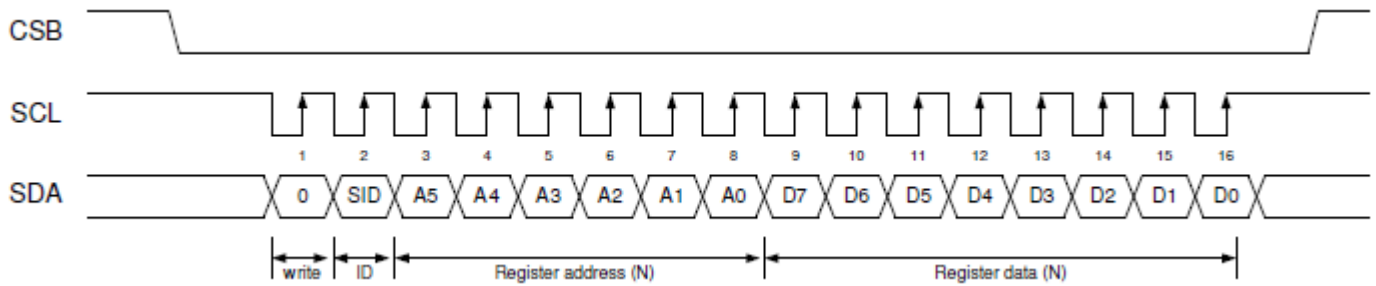

6.1.3 SPI timing

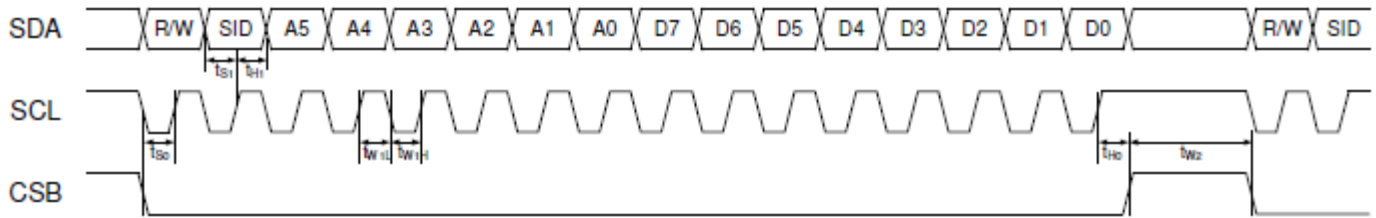

Parameter	Symbol	Conditions	Spec.			Unit
			Min.	Typ.	Max.	
SDA setup time	t_{S0}	CSB to SCL	60	-	-	ns
	t_{S1}	SDA to SCL	60	-	-	ns
SDA hold time	t_{H0}	CSB to SCL	60	-	-	ns
	t_{H1}	SDA to SCL	60	-	-	ns
Pulse width	t_{W1L}	SCL pulse width	75	-	-	ns
	t_{W1H}	SCL pulse width	75	-	-	ns
	t_{W2}	CSB pulse width	1	-	-	μ s
Clock duty	-	-	40	50	60	%

6.2 RGB interface characteristic

- Horizontal

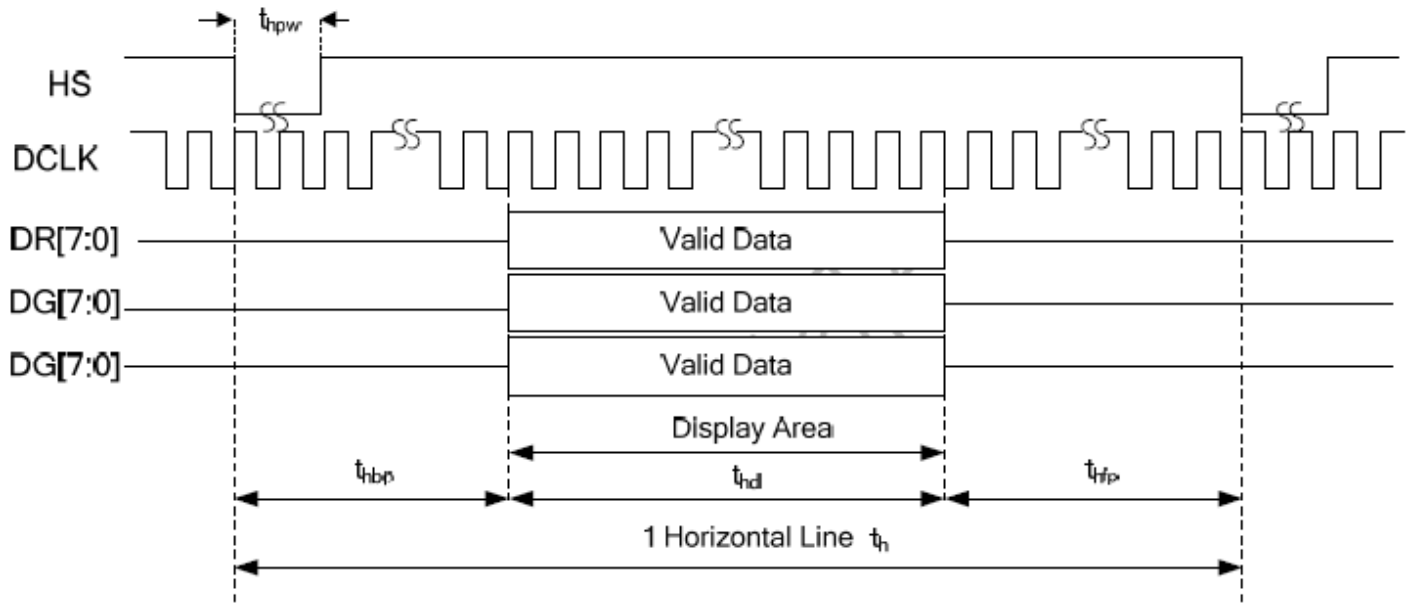

- Vertical

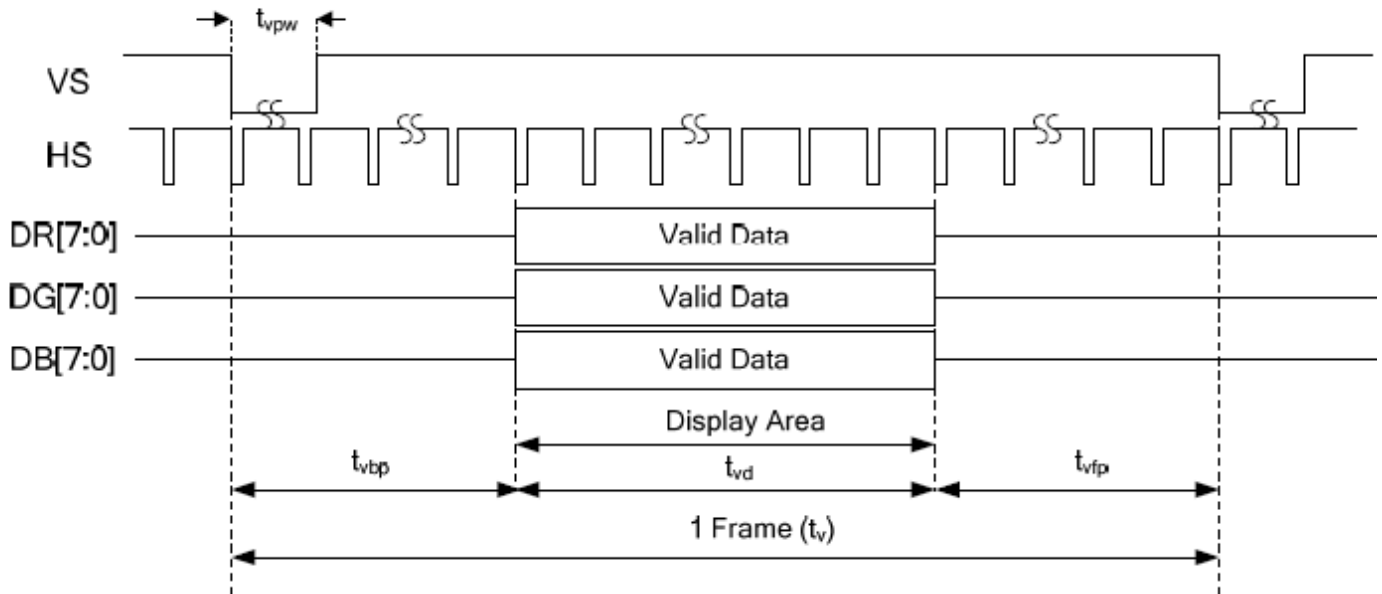

Timings for RGB I/F

Item	Symbol	Min.	Typ.	Max.	Unit
DCLK frequency	FDCLK		38		MHz
Horizontal valid data	thd	720	720	720	DCLK
Hsync pulse width	thpw	1	2	88	DCLK
Hsync back porch	thbp	5	16	89	DCLK
Hsync front porch	thfp	19	64	103	DCLK
1 horizontal line	th	776	780	828	DCLK
Vertical valid data	tvd	720	720	720	H
Vsync pulse width	tvpw	1	2	38	H
Vsync back porch	tvbp	5	5	139	H
Vsync front porch	tvfp	5	67	139	H
1 vertical field	tv	730	792	864	H

6.3 RGB interface General Timing

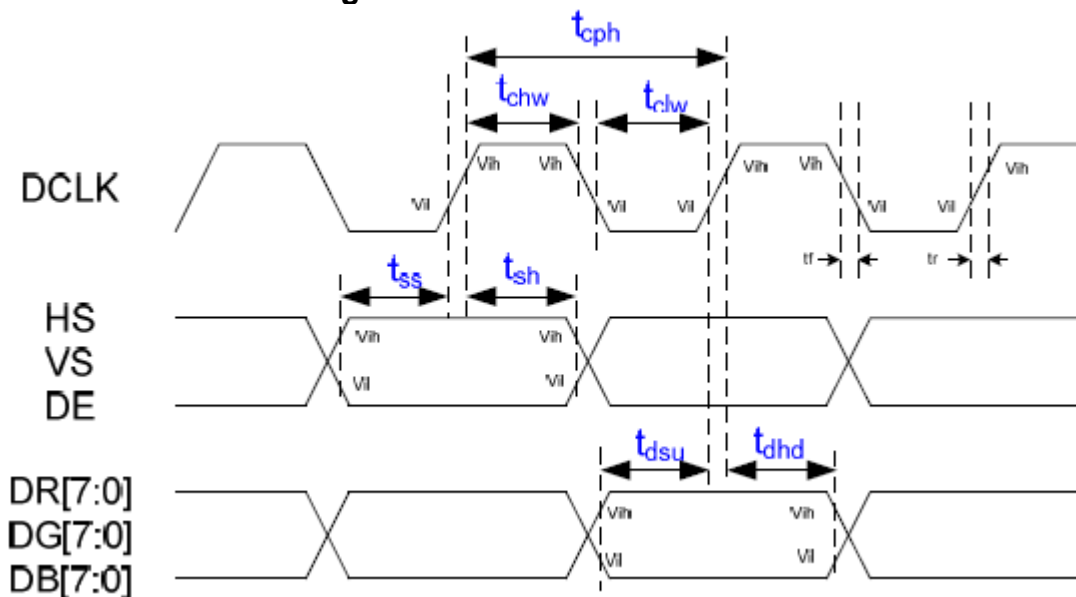
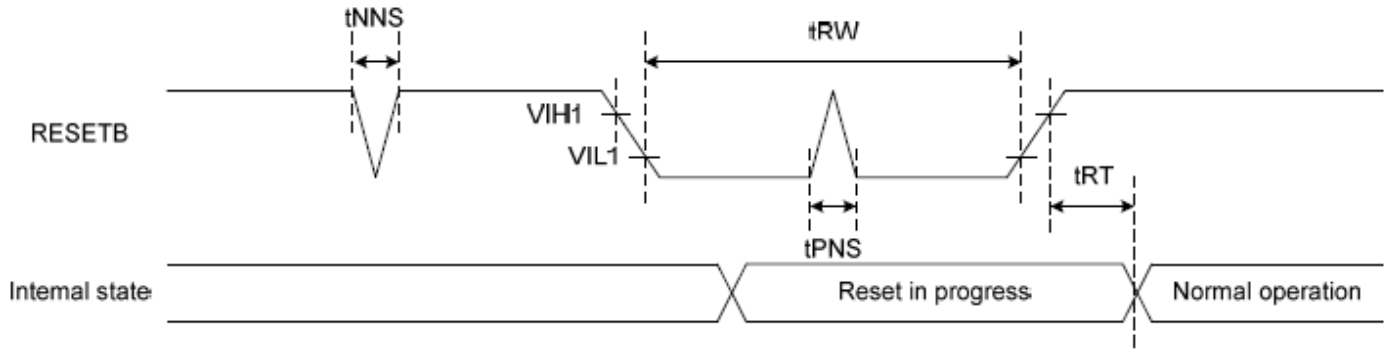

Figure 5.2.3.1 General Timings for RGB I/F

Parameter	Symbol	Spec.			Unit
		Min.	Typ.	Max.	
DCLK period	T_{cph}	16.8	-	-	ns
DCLK clock high width	T_{chw}	6	-	-	ns
DCLK clock low width	T_{clw}	6	-	-	ns
VS setup time	T_{ss}	5	-	-	ns
VS hold time	T_{sh}	5	-	-	ns
HS setup time	T_{ss}	5	-	-	ns
HS hold time	T_{sh}	5	-	-	ns
DE setup time	T_{ss}	5	-	-	ns
DE hold time	T_{sh}	5	-	-	ns
Data setup time	T_{dsu}	5	-	-	ns
Data hold time	T_{dhd}	5	-	-	ns
Input signal rising time	T_r	-	-	10	ns
Input signal falling time	T_f	-	-	10	ns

6.4 Reset Input Timing



Signal	Paramete	Symbol	Spec.			Unit
			Min.	Typ.	Max.	
RESETB	Reset pulse width	tRW	10	-	-	μs
	Reset complete time	tRT	-	-	5	μs
	Positive spike noise width	tPNS	-	-	100	ns
	Negative spike noise width	tNNS	-	-	100	ns

7. LCD PIN CONNECTIONS

Pin No	Symbol	Description	Remark
1	NC	No Connection	
2	VDD	Power supply for analog system	
3	VDD		
4	GND	Ground	
5	/RESX	This signal will reset the device and must be applied to properly initialize the chip. Signal is active low.	
6	SDA	Serial data input signal.	
7	NC	No Connection	
8	SCL	Serial data clock signal.	
9	CSX	Chip select input pin ("Low" enable).	
10	DCLK	Pixel clock signal.	
11	DE	Data enable signal.	
12	VSYNC	Vertical sync.	
13	HSYNC	Horizontal sync.	
14	GND	Ground	
15	DB0	RGB data bus.	
16	DB1		
17	DB2		
18	DB3		
19	DB4		
20	DB5		
21	DB6		
22	DB7		
23	GND	Ground	
24	DB8	RGB data bus.	
25	DB9		
26	DB10		
27	DB11		
28	DB12		
29	DB13		
30	DB14		
31	DB15		
32	GND	Ground	
33	DB16	RGB data bus.	
34	DB17		
35	DB18		
36	DB19		
37	DB20		
38	DB21	RGB data bus.	
39	DB22		
40	DB23		
41	GND	Ground	

42	LEDA	Power Supply for LED+	
43	LEDA		
44	LEDK	Power Supply for LED-	
45	LEDK		

Pixel mapping

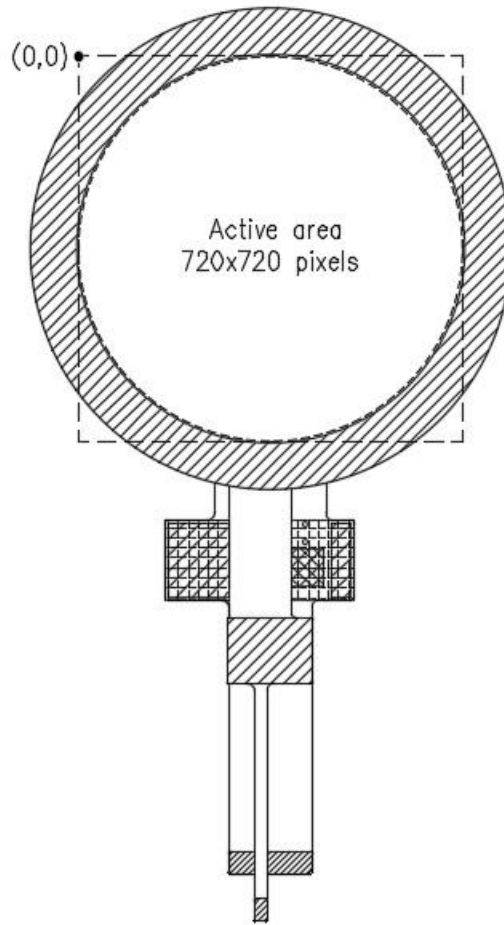

8. LCD INITIAL CODE

SPIW 00 00 //page 0
SPIW 03 F1 //RES 720x720
SPIW 04 40 //Gate right
SPIW 26 51 // Gate pass
SPIW 27 68 // Gate pass
SPIW 18 75 //DRVP TonTOff
SPIW 19 75 //DRVN TonTOff

SPIW 20 7F //VCOM

SPIW 00 01 //page 1 Gamma

SPIW 01 00
SPIW 02 00
SPIW 03 07
SPIW 04 04
SPIW 05 1b //
SPIW 06 07
SPIW 07 0d
SPIW 08 14
SPIW 09 17
SPIW 0a 18
SPIW 0b 1d
SPIW 0c 1e
SPIW 0d 1f
SPIW 0e 19
SPIW 0f 0f
SPIW 10 1c //
SPIW 11 00
SPIW 12 00
SPIW 13 0c

SPIW 14 00
SPIW 15 00
SPIW 16 07
SPIW 17 04
SPIW 18 1b //
SPIW 19 07
SPIW 1a 0d
SPIW 1b 14
SPIW 1c 17
SPIW 1d 18
SPIW 1e 1d
SPIW 1f 1e
SPIW 20 1f
SPIW 21 19
SPIW 22 0f
SPIW 23 1c //
SPIW 24 00
SPIW 25 00
SPIW 26 0c

9. CTP SPECIFICATIONS

9.1 GENERAL SPECIFICATIONS

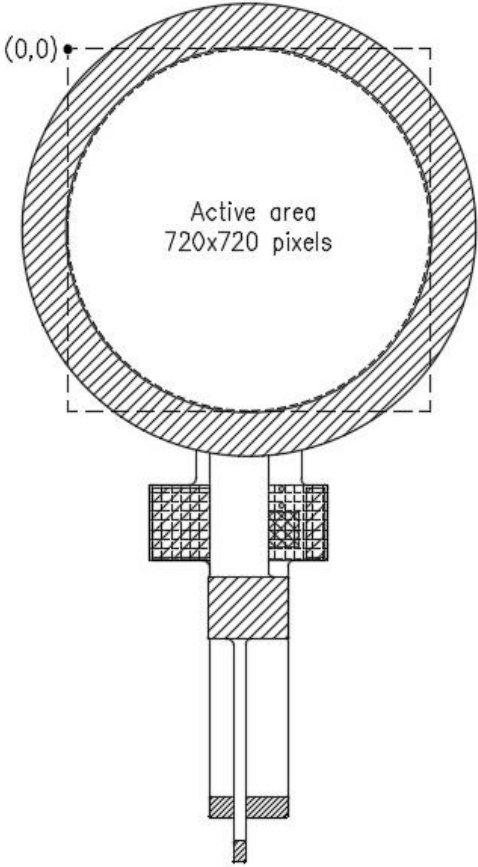
Item	Specification	Unit
Type	Transparent type projected capacitive touch panel	
Input mode	Human's finger	
Multi touch	2	Point
Interface	I ² C	
Origin point		

9.2 Electrical Characteristic

9.2.1 Absolute Maximum Rating

Parameter	Symbol	Spec.			Unit
Supply voltage	VCC	-0.3	-	6	V

9.2.2 DC Characteristic

Symbol	Description	Min	Typ.	Max.	Unit	Notes
VCC	Supply voltage	3.0	3.3	3.6	V	
ICC	Supply current		40		mA	VCC=3.3V
VIH	Input High Voltage	0.85*VCC		3.6	V	
VIL	Input Low Voltage	0		0.15*VCC	V	

9.2.3 CTP Pin Function

Pin No.	Symbol	Function
1	VCC	Power for CTP
2	SCL	CTP I ² C Clock
3	SDA	CTP I ² C Data
4	/TP_INT	CTP interrupt pin, active low.
5	/TP_RST	CTP reset input pin, active low.
6	GND	Ground

9.3 AC electrical characteristics

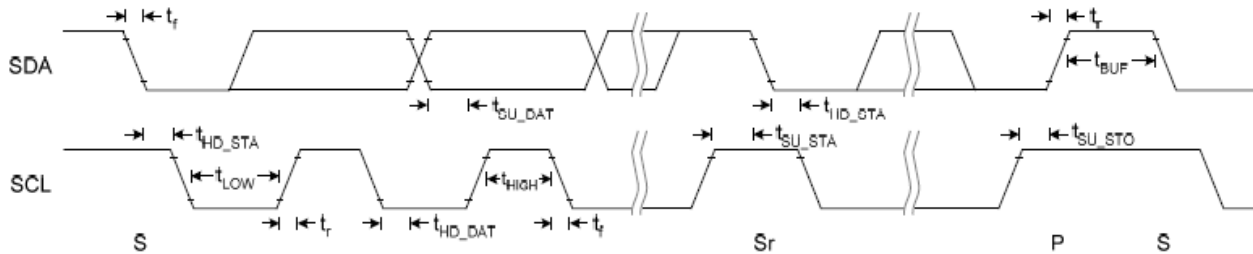

I2C Fast mode timing

Conditions :VDD=3.3V GND=0V TA=25°C

Symbol	Parameter	Rating			Unit
		Min.	Typ.	Max.	
f_{SCL}	SCL clock frequency	0	-	400	kHz
t_{LOW}	Low period of the SCL clock	1.3	-	-	us
t_{HIGH}	High period of the SCL clock	0.6	-	-	us
t_f	Signal falling time	-	-	300	ns
t_r	Signal rising time	-	-	300	ns
t_{SU_STA}	Set up time for a repeated START condition	0.6	-	-	us
t_{HD_STA}	Hold time (repeated) START condition. After this period, the first clock pulse is generated	0.6	-	-	us
t_{SU_DAT}	Data set up time	100	-	-	ns
t_{HD_DAT}	Data hold time	0	-	0.9	us
t_{SU_STO}	Set up time for STOP condition	0.6	-	-	us
t_{BUF}	Bus free time between a STOP and START condition	1.3	-	-	us
C_b	Capacitive load for each bus line	-	-	400	pF

9.4 I2C Host Interface Protocol

9.4.1 Initialization

After hardware reset, touch controller needs some time for initialization. The touch controller can be accessed via I2C or SPI interface after initialization.

Touch IC	Initialization Time
ST1912/ST1727	65ms
ST1x32/ST1x28/ST1x30/ ST1x34/ST1x36/ST1x33i/ ST1x33/ST1x24/ST1615	50ms

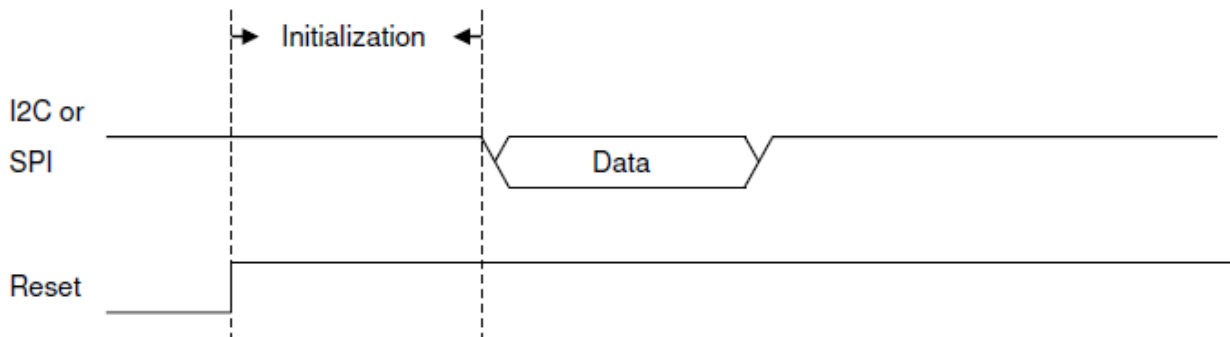

9.4.2 I2C Host Interface Protocol

All Sitronix Touch ICs support I2C interface protocol for communication.

9.4.3 Default I2C Address

I2C address is default to 0x55 (7-bits address) for Touch IC. If the I2C address is conflict with another I2C device's address on same bus, user can change I2C address by TTK PC Utility.

9.4.4 Register Read

For reading register value from I2C device, host has to tell I2C device the *Start Register Address* before reading corresponding register value.

I2C Start	I2C Header (W)	Start Reg. Addr.	I2C Stop	I2C Start	I2C Header (R)	Value of Reg(a)	Value of Reg(a+1)	...	Value of Reg(a+n)	I2C Stop
		(a)								

Figure 1 - Register Read Format.

Sitronix

Touch IC I2C host interface protocol supports *Repeated Register Read*. That is, once the *Start Register Address* has been set by host, consequent I2C Read(R) transactions will directly read register values starting from the *Start Register Address* without setting address first, as shown in Figure 2.

I2C Start	I2C Header (R)	Value of Reg(a)	Value of Reg(a+1)	...	Value of Reg(a+n)	I2C Stop	I2C Start	I2C Header (R)	Value of Reg(a)	Value of Reg(a+1)	...	Value of Reg(a+n)	I2C Stop

Figure 2 - Repeated Register Read.

9.4.5 Register Write

For writing register to I2C device, host has to tell I2C device the Start Register Address in each I2C Register Write transaction. Register values to the I2C device will be written to the address starting from the Start Register Address described in Register Write I2C transaction as shown in Figure 3.

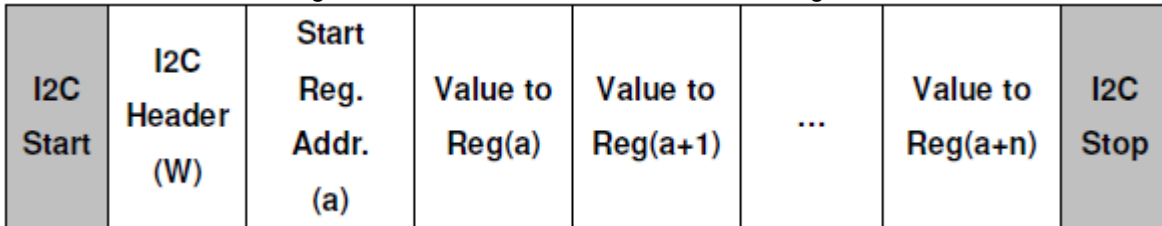
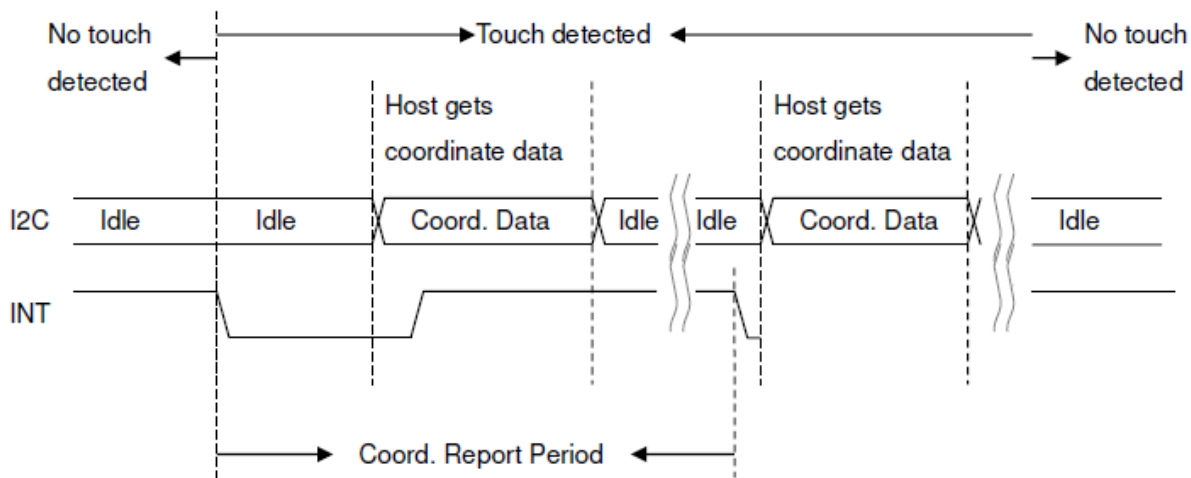

Figure 3 - Register Write Format.

9.4.6 I2C Electrical Waveform



9.5 SPI Host Interface Protocol

Some Sitronix Touch ICs, like ST1727, support SPI interface protocol for communication.

To read/write register data through SPI interface, the *Register Address* has to be transmitted on MOSI first. The *Register Address* in SPI protocol is two bytes wide, with MSB (bit 15) being '1' for SPI read transaction, and '0' for SPI write transaction.

For each read/write transaction, host can receive the *SPI Status* from device on MISO. The *SPI Status* indicates that the SPI transaction is failed or not.

SPI Status	Description
0x00	Device is normal. No error on SPI transaction.
0x80	Device is busy. SPI transaction failed.
Others	Reserved.

While touch controller is in Power While touch controller is in Power Down mode, pulling SS pin to low triggers touch controller to wake up from

Power Down mode. In this situation, touch controller needs a few time (100μ s) for hardware warm up and 1st SPI transmission data before 2nd SPI transmission starts.

The specific SPI read and write transaction are described as following.

9.6 Register Read

The following figure presents a typical SPI read transaction.
 The limitation of T_p can be ignored if touch controller is not in power down mode.

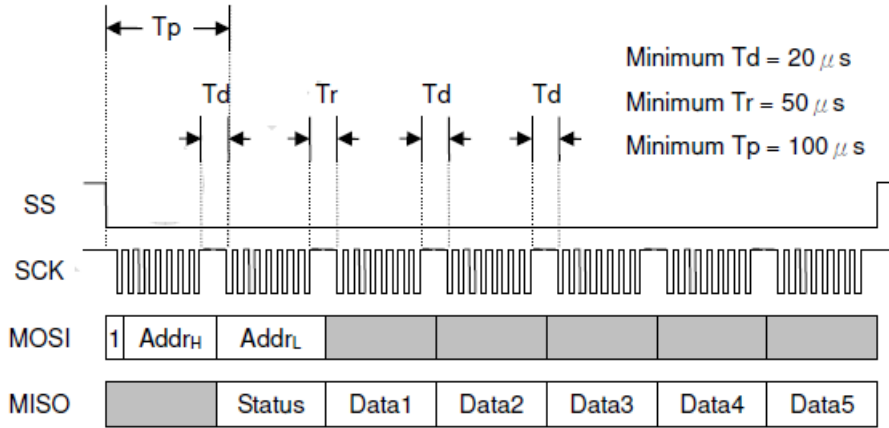

9.7 Register Write

The following figure presents a typical SPI write transaction.
 The limitation of T_p can be ignored if touch controller is not in power down mode.

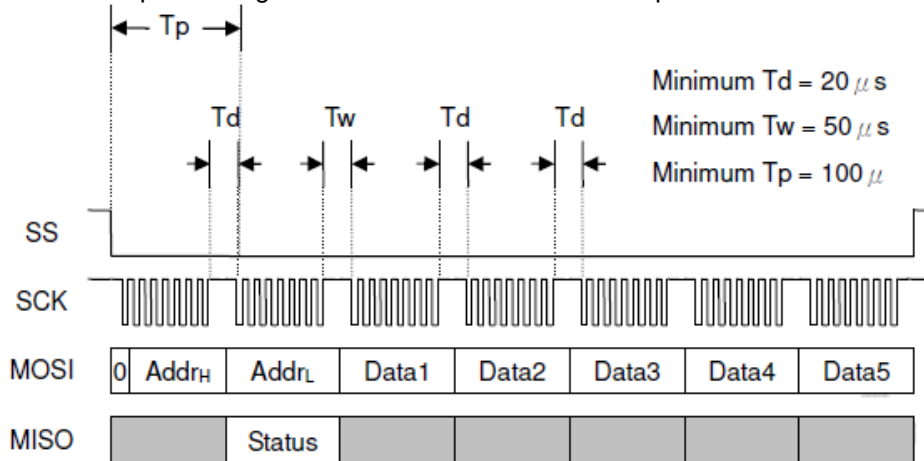

9.8 SPI Electrical Waveform

Sitronix Touch ICs support SPI mode 3 (PHA = 1 & POL = 1) for communication. The SPI clock can be up to 8MHz.

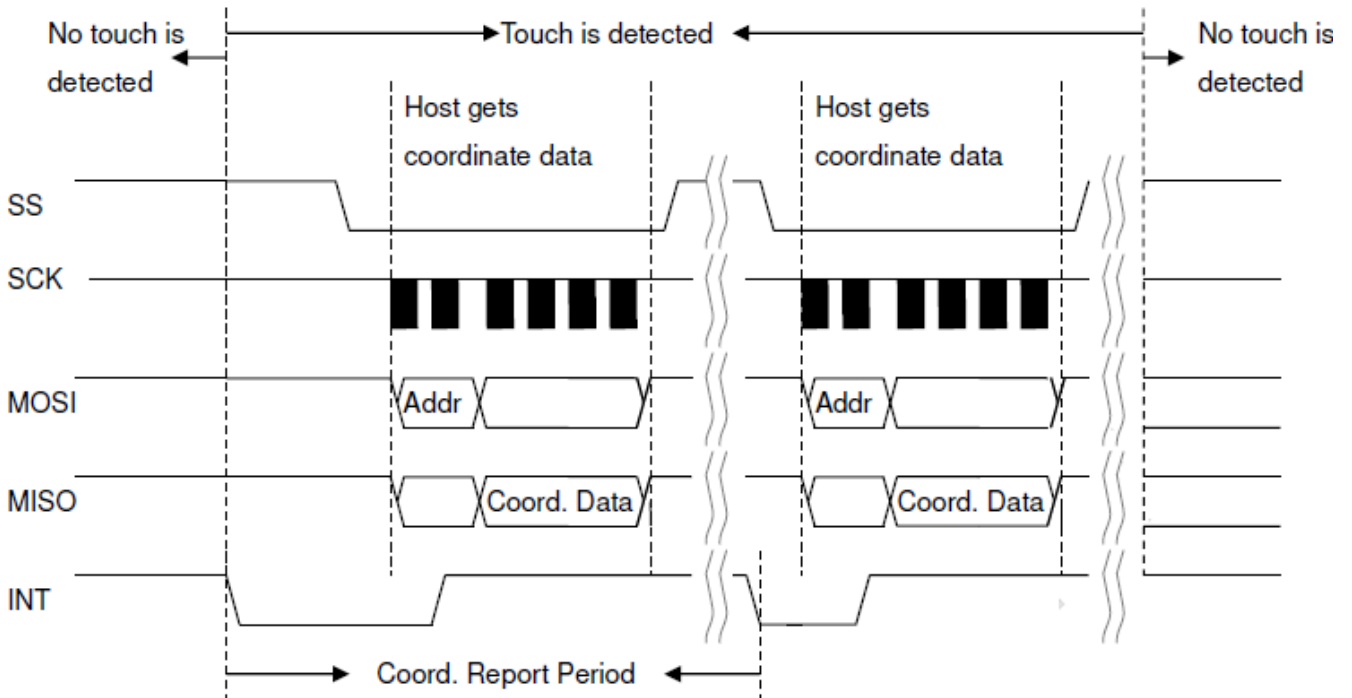
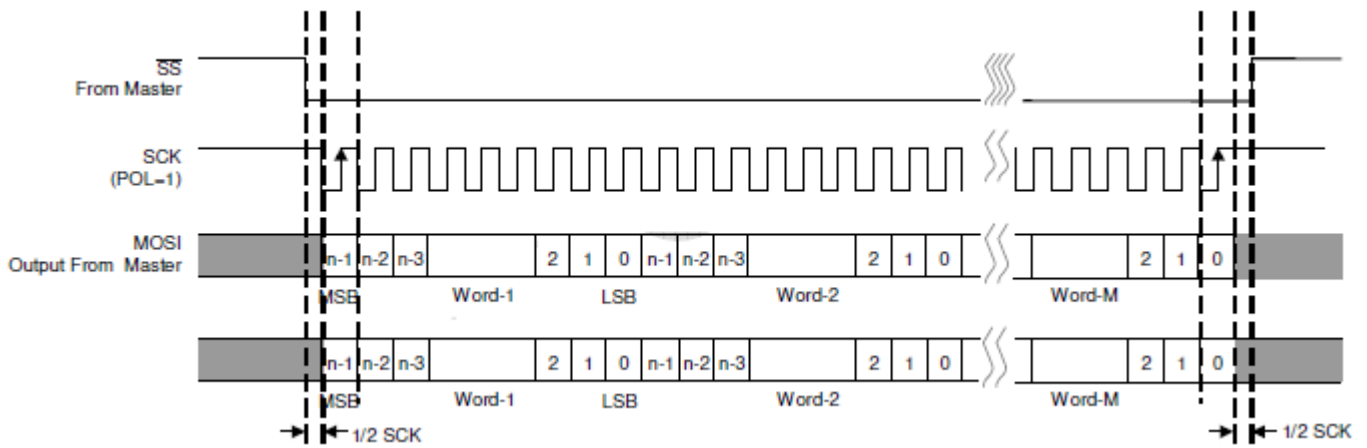

9.9 Report Page Registers

Sitronix Touch IC provides a register set for host to configure device attributes and retrieve information about fingers and raw data through device host interface. Host interface registers are listed below.

Host Interface Registers (Report Page)									
Reg. Addr.	Name	Bit 7	Bit 6	Bit 5	Bit 4	Bit 3	Bit 2	Bit 1	Bit 0
0x00	Firmware Version	Version (RO)							
0x01	Status Reg.	Error Code (RO)				Device Status (RO)			
0x02	Device Control Reg.	Reserved	Multi-Touch Disable (RW)	Proximity Enable (RW)	Reserved	Reserved	Deep Power Down (RW)	Power Down (RW)	Reset (RW)
0x03	Timeout to Idle Reg.	Timeout to Idle (sec.) (RW)							
0x04	XY Resolution (High Byte)	Reserved	X_Res_H (RO)			Reserved	Y_Res_H (RO)		
0x05	X Resolution (Low Byte)	X_Res_L (RO)							
0x06	Y Resolution (Low Byte)	Y_Res_L (RO)							
0x07	Sensing Counter (High Byte)	Sensing_Counter_H (RO)							
0x08	Sensing Counter (Low Byte)	Sensing_Counter_L (RO)							
0x09 ... 0x0B	...	Reserved							
0x0C	Firmware Revision 3	FW_Rev_3 (RO)							
0x0D	Firmware Revision 2	FW_Rev_2 (RO)							
0x0E	Firmware Revision 1	FW_Rev_1 (RO)							
0x0F	Firmware Revision 0	FW_Rev_0 (RO)							
0x10	Advanced Touch Info.	Reserved	Proximity Flag (RO)	Water Flag (RO)	Reserved	Gesture Type(RO)			
0x11	Keys Reg.	Keys (RO)							
0x12	XY0 Coord. (High Byte)	Valid 0 (RO)	X0_H (RO)			Reserved	Y0_H (RO)		

Host Interface Registers (Report Page)									
Reg. Addr.	Name	Bit 7	Bit 6	Bit 5	Bit 4	Bit 3	Bit 2	Bit 1	Bit 0
0x13	X0 Coord. (Low Byte)	X0_L (RO)							
0x14	Y0 Coord. (Low Byte)	Y0_L (RO)							
0x15	...	<i>Reserved.</i>							
0x16	XY1 Coord. (High Byte)	Valid 1 (RO)	X1_H (RO)			<i>Reserved</i>	Y1_H (RO)		
0x17	X1 Coord. (Low Byte)	X1_L (RO)							
0x18	Y1 Coord. (Low Byte)	Y1_L (RO)							
0x19	...	<i>Reserved.</i>							
0x1A ... 0x35							
0x36	XY9 Coord. (High Byte)	Valid 9 (RO)	X9_H (RO)			<i>Reserved</i>	Y9_H (RO)		
0x37	X9 Coord. (Low Byte)	X9_L (RO)							
0x38	Y9 Coord. (Low Byte)	Y9_L (RO)							
0x39	Reserved	<i>Reserved.</i>							
0x3A ... 0x3E	...	<i>Reserved</i>							
0x3F	Contact Count Max.	Max Number of Contacts Support (RO)							
0x40 ... 0xCA	...	<i>Reserved</i>							
0xCB	PWM0 Duty	<i>Reserved</i>	PWM0 Duty (RW)						
0xCC	PWM1 Duty	<i>Reserved</i>	PWM1 Duty (RW)						
0xCD	PWM2 Duty	<i>Reserved</i>	PWM2 Duty (RW)						
0xCE	PWM3 Duty	<i>Reserved</i>	PWM3 Duty (RW)						
0xCF	PWM Control	PWM Trigger (RW)	PWM Clock (RW)			PWM3 Enable (RW)	PWM2 Enable (RW)	PWM1 Enable (RW)	PWM0 Enable (RW)
0xD0 ... 0xEF	...	<i>Reserved</i>							
0xF0	Misc. Info.	Smart Wake Up Flag (RO)	<i>Reserved</i>						

Host Interface Registers (Report Page)									
Reg. Addr.	Name	Bit 7	Bit 6	Bit 5	Bit 4	Bit 3	Bit 2	Bit 1	Bit 0
0xF1	Misc. Control	Enable Smart Wake Up (RW)	Reserved						
0xF2	Smart Wake Up ID	Smart Wake Up ID (RW)							
0xF3 ... 0xFE	...	Reserved							
0xFF	Page Reg.	Page Number (RW)							

Figure 4 – Host Interface Registers

9.9.1 Firmware Version Register

Reg. Addr.	Name	Bit 7	Bit 6	Bit 5	Bit 4	Bit 3	Bit 2	Bit 1	Bit 0
0x00	Firmware Version	Version (RO)							

Firmware Version Register provides version information about current firmware. Host application can support version control in firmware upgrade function by reading *Firmware Version Register* and comparing with the version of new firmware binary.

9.9.2 Status Register

Reg. Addr.	Name	Bit 7	Bit 6	Bit 5	Bit 4	Bit 3	Bit 2	Bit 1	Bit 0
0x01	Status Reg.	Error Code (RO)				Device Status (RO)			

Status Register shows current status of the device to host, including *Device Status* and *Error Code*. *Init* status represents that the device is in *Init* state and not ready for host access. Host has to wait for the device to change into *Normal* state before accessing registers other than *Status Register*. If *Device Status* shows *Error*, the *Error Code* field in the *Status Register* gives reason of the error.

Device Status	
0x0	Normal
0x1	Init
0x2	Error
0x3	Auto Tuning
0x4	Idle
0x5	Power Down
0x6	Boot ROM
0x7	Waiting to execute Sub-AP
0x8 ... 0xF	Reserved

Error Code	
0x0	No Error
0x1	Invalid Address
0x2	Invalid Value
0x3	Invalid Platform
0x4	Dev Not Found
0x5	Stack Overflow
0x6	Invalid Firmware Parameter Table
0x7	Invalid Secondary Touch Firmware
0x8	<i>Reserved</i>
...	
0xF	

9.9.3 Device Control Register

Reg. Addr.	Name	Bit 7	Bit 6	Bit 5	Bit 4	Bit 3	Bit 2	Bit 1	Bit 0
0x02	Device Control Reg.	<i>Reserved</i>	Multi-Touch Disable (RW)	Proximity Enable (RW)	<i>Reserved</i>		Deep Power Down (RW)	Power Down (RW)	Reset (RW)

Device Control Register provides device control bits for host to reset the device or power down the device. The “Multi-Touch Disable” control bit is only available for ST1236/ST1336/ST1530/ST1536 touch IC. “Multi-Touch Disable” control bit is used to configure touch detector as single touch or multi-touch detector. The default setting of this control bit is cleared to 0 and touch device can report multiple touch positions. Set “Multi-Touch Disable” control bit to 1 makes the touch device to report only one touch position. **The “Multi-Touch Disable” control bit is useless in triangle projects.**

For ST1x56/ST1x64/ST1x64A/ST1x72 series touch IC:

When host sets Power Down bit, touch sensor controller will enter power down mode. Host can pull I2C INT pin to low to wake up the controller.

For ST1x32/ST1x28/ST1x30/ST1x34/ST1x36/ST1x33i/ST1x33/ST1x24/ST1615/ST1912/ST1727/ST1727 series touch IC:

When host sets Power Down bit, touch sensor controller will enter power down mode. Host can clear Power Down bit to wake up the controller.

The “Proximity Enable” control bit is only for some triangle projects.

Host sets “Proximity Enable” bit to 1 to enable proximity function and clear it to disable. The proximity information is shown in “Proximity Flag” of “Advanced Touch Information” register.

Host sets “Proximity Enable” bit to 1 to enable proximity function and clear it to disable. The proximity information is shown in “Proximity Flag” of “Advanced Touch Information” register.

For ST1912/ST1727 touch IC:

Only ST1912/ST1727 touch IC supports *Deep Power Down* function. *Deep Power Down* bit provides deep power down mode to save more power consumption than *Power Down* mode. In *Power Down* mode, the power of DRAM in touch IC is still turned on. But in *Deep Power Down* mode, the power of DRAM in touch IC is turned off. All previous state information which are stored in DRAM will be missing. So, touch IC needs more initialization time for leaving *Deep Power Down* mode.

Please always write 0 into reserved bits.

9.9.4 Timeout to Idle Register

Reg. Addr.	Name	Bit 7	Bit 6	Bit 5	Bit 4	Bit 3	Bit 2	Bit 1	Bit 0
0x03	Timeout to Idle Reg.	Timeout to Idle (sec.) (RW)							

Timeout to Idle Register provides timeout control to enter Idle Mode for host. The touch controller will enter Idle Mode after the number of seconds specified in Timeout to Idle Register if there is no touch detected in this period. Set this field to 0xFF will disable Idle Mode. Set this field to 0 will entering Idle Mode immediately. Idle state will be updated to Device Status field of Status Register, 0x01, after entering Idle Mode automatically. The default value of Timeout to Idle Register is set to 0x08 for 8 seconds to Idle Mode.

9.9.5 XY Resolution Registers

Reg. Addr.	Name	Bit 7	Bit 6	Bit 5	Bit 4	Bit 3	Bit 2	Bit 1	Bit 0
0x04	XY Resolution (High Byte)	Reserved	X_Res_H (RO)			Reserved	Y_Res_H (RO)		
0x05	X Resolution (Low Byte)	X_Res_L (RO)							
0x06	Y Resolution (Low Byte)	Y_Res_L (RO)							

XY Resolution Registers represents resolution of X and Y coordinates of the touch screen.

9.9.6 Sensing Counter Registers

Reg. Addr.	Name	Bit 7	Bit 6	Bit 5	Bit 4	Bit 3	Bit 2	Bit 1	Bit 0
0x07	Sensing Counter (High Byte)	Sensing_Counter_H (RO)							
0x08	Sensing Counter (Low Byte)	Sensing_Counter_L (RO)							

Sensing Counter Registers provide a frame-based scan counter for host to verify current scan rate. This counter will be increased by one each time when a frame data is produced by the controller scanning system.

9.9.7 Firmware Revision Registers

Reg. Addr.	Name	Bit 7	Bit 6	Bit 5	Bit 4	Bit 3	Bit 2	Bit 1	Bit 0
0x0C	Firmware Revision 3	FW_Rev_3 (RO)							
0x0D	Firmware Revision 2	FW_Rev_2 (RO)							
0x0E	Firmware Revision 1	FW_Rev_1 (RO)							
0x0F	Firmware Revision 0	FW_Rev_0 (RO)							

9.9.8 Advanced Touch Information Register

Reg. Addr.	Name	Bit 7	Bit 6	Bit 5	Bit 4	Bit 3	Bit 2	Bit 1	Bit 0
0x10	Advanced Touch Info.	Reserved	Proximity Flag (RO)	Water Flag (RO)	Reserved	Gesture Type (RO)			

Advanced Touch Information field provides some advanced touch information, like proximity, for host.

Touch controller sets proximity flag to 1 to notify host that the human body is very close to proximity sensor.

The “Proximity Flag” is only shown and used for some triangle projects.

If proximity flags are changed, the touch controller will output INT pin as low to notify host.

The “Water Flag” information is only shown and used for smart watch projects. It is used to notify host that the smart watch may fall into the water.

Water Flag = 0: The smart watch doesn’t fall into the water.

Water Flag = 1: The smart watch may fall into the water. In this situation, the touch controller will output INT pin as low to notify host whether touch is detected or not.

The “Gesture Type” information is an optional function only for some specific projects.

It defines following gestures:

Gesture Type = 0: No gesture.

Gesture Type = 1: Reserved.

Gesture Type = 2: Zoom in.

Gesture Type = 3: Zoom out.

Gesture Type = 4: Left to right slide. (→)

Gesture Type = 5: Right to left slide. (←)

Gesture Type = 6: Top to down slide. (↓)

Gesture Type = 7: Down to top slide. (↑)

Gesture Type = 8: Palm.

Gesture Type = 9: Single tap.

Gesture Type = 10: Long press.

If a finger is fixed on touch panel and continues over a specified duration, the touch controller generates a Long Press (Gesture Type = 10) gesture and outputs INT pin as Low to notify host. If the finger is still fixed on touch panel after Long Press gesture and over the specified duration again, the touch controller will generate a Long Press (Gesture Type = 10) gesture again and output INT pin as Low to notify host.

Gesture Type = 11: Reserved.

Gesture Type = 12: Drag.

If the finger moves on the touch panel after Long Press gesture, the touch controller generates a Drag gesture and outputs INT pin as Low to notify host.

Gesture Type = 13: Clockwise rotation.

This gesture is only supported for some special touch sensor pattern.

Gesture Type = 14: Counterclockwise rotation.

This gesture is only supported for some special touch sensor pattern.

ICs support 2 kinds of operation mode which are "Gesture Only" mode and "Report Coordinate" mode. The “Gesture Only” mode and “Report Coordinate” mode can only be chosen either of them.

In “Gesture Only” mode, the touch controller will output INT pin as Low in three situations which are “Touch In”, “Gesture Detected” and “Touch Leave”.

In “Touch In” state, it means that the finger has just touched on touch panel. The gesture type will be 0 and the “Valid” bit of coordinate will be 1. The touch controller outputs INT pin as Low to notify Host. Host can get “Touch In” coordinate in this state.

In “Gesture Detected” state, it means that the finger is still touched on touch panel but some specified gestures are detected by touch controller. The touch controller outputs INT pin as Low to notify Host. Host can get gesture type information to know what gesture happens.

In “Touch Leave” state, it means that the finger has just left from touch panel. The “Valid” bit of coordinate will be 0. And the touch controller stores the detected gesture information into Gesture Type Register. Then the touch controller outputs INT pin as Low to notify Host. Host can get “Touch Leave” coordinate and gesture type information in this state.

In “Report Coordinate” mode, the touch controller will output INT pin as Low while touch is detected every

sensing frame.

The timing of touch controller to update latest information into “Advanced Touch Information Register”, “Keys Register” and “XY Coordinate Registers” is when host reads register data via I2C interface with specified start address 0x10 or 0x11 or 0x12.

9.9.9 Keys Register

Reg. Addr.	Name	Bit 7	Bit 6	Bit 5	Bit 4	Bit 3	Bit 2	Bit 1	Bit 0
0x11	Keys	Keys (RO)							

Key field represents which key is pressed or released. Each bit in the *Key* field represents the pressed or released state of one key. If the bit is set, it means that the corresponding key is pressed. Otherwise, the key is released.

9.9.10 XY Coordinate Registers

Reg. Addr.	Name	Bit 7	Bit 6	Bit 5	Bit 4	Bit 3	Bit 2	Bit 1	Bit 0
0x12	XY0 Coord. (High Byte)	Valid 0 (RO)	X0_H (RO)			Reserved	Y0_H (RO)		
0x13	X0 Coord. (Low Byte)	X0_L (RO)							
0x14	Y0 Coord. (Low Byte)	Y0_L (RO)							
0x15	...	Reserved.							

XY Coordinate Registers represent the XY coordinates for each touch point ID. Valid bit field tells that this point ID is valid and the XY information represents a real touch point on touch sensor.

9.9.11 Maximum Number of Contacts Support Register

Reg. Addr.	Name	Bit 7	Bit 6	Bit 5	Bit 4	Bit 3	Bit 2	Bit 1	Bit 0
0x3F	Contact Count Max.	Max Number of Contacts Support (RO)							

It's a read-only feature for getting the total number of contacts that the touch sensor controller supports.

9.9.12 PWM Control Registers

Reg. Addr.	Name	Bit 7	Bit 6	Bit 5	Bit 4	Bit 3	Bit 2	Bit 1	Bit 0
0xCB	PWM0 Duty	Reserved	PWM0 Duty (RW)						
0xCC	PWM1 Duty	Reserved	PWM1 Duty (RW)						
0xCD	PWM2 Duty	Reserved	PWM2 Duty (RW)						
0xCE	PWM3 Duty	Reserved	PWM3 Duty (RW)						
0xCF	PWM Control	PWM Trigger (RW)	PWM Clock (RW)			PWM3 Enable (RW)	PWM2 Enable (RW)	PWM1 Enable (RW)	PWM0 Enable (RW)

Only ST1912/ST1727 touch IC support *PWM Control Registers* field.

The *PWM Control Registers* provide some PWM configuration like clock, duty and enable/disable control.

Host can configure the PWM0 ~ PWM3 modules via *PWM Control Registers*.

PWM0 ~ PWM3 Duty registers control the high level time of each PWM duty.

0x00 = 0/64

0x01 = 1/64

0x02 = 2/64

::

0x3F = 63/64

0x40 = 64/64

PWM0 ~ PWM3 Enable bits are used to turn on/off each PWM module.

0 = Disable PWM. (Turn off PWM)

1 = Enable PWM. (Turn on PWM)

PWM Clock bits is used to select the PWM clock source for all PWM modules.

000 = 1000 Hz

001 = 500 Hz

010 = 250 Hz

011 = 125 Hz

100 = 62.5 Hz

PWM Trigger bit is used to update new PWM configuration into all PWM module. Host sets PWM Trigger bit to notify touch IC that some PWM control registers have been modified. And touch IC updates new PWM configuration into all PWM modules when it detects that the PWM Trigger bits is set. Touch IC will clear the PWM Trigger bit automatically after it finish the PWM configuration. All PWM control registers modification, including PWM duty, PWM clock and PWM enable, will not be updated into PWM modules until host sets PWM Trigger bit.

9.9.13 Miscellaneous Information Register

Reg. Addr.	Name	Bit 7	Bit 6	Bit 5	Bit 4	Bit 3	Bit 2	Bit 1	Bit 0
0xF0	Misc. Info.	Smart Wake Up Flag (RO)	Reserved.						

Miscellaneous Information Register provides some misc. information to host.

The "Smart Wake Up" function is an optional for customer. The "Smart Wake Up Flag" shows that does the current touch firmware support smart wake up function or not.

Smart Wake Up Flag = 0: Current touch firmware does not support smart wake up function.

Smart Wake Up Flag = 1: Current touch firmware supports smart wake up function.

9.9.14 Miscellaneous Control Register

Reg. Addr.	Name	Bit 7	Bit 6	Bit 5	Bit 4	Bit 3	Bit 2	Bit 1	Bit 0
0xF1	Misc. Control	Enable Smart Wake Up (RW)	Reserved.						

Miscellaneous Control Register provides miscellaneous control bits for some special functions.

Host can set/clear "Enable Smart Wake Up" bit to enable/disable "Smart Wake Up" function.

To enable smart wake up function, the "Enable Smart Wake Up" bit should be set before power down the touch controller. The touch controller will be in "Doze" mode after power down. In this mode, touch driver is still sensing the touch panel but as saving power as possible.

Once the specified handwriting gesture is detected, touch controller wakes host up via "INT" pin and the identification of handwriting gesture will be put into "Smart Wake Up ID" register. After host gets "Smart Wake Up ID", host can clear the "Smart Wake Up ID" register.

Please always write 0 into reserved bits.

9.9.15 Smart Wake Up ID Register

Reg. Addr.	Name	Bit 7	Bit 6	Bit 5	Bit 4	Bit 3	Bit 2	Bit 1	Bit 0
0xF2	Smart Wake Up ID	Smart Wake Up ID (RW)							

Smart Wake Up ID Register provides various handwriting identifications of smart wake up function. After host gets "Smart Wake Up ID" from this register, host can clear this register to zero.

Smart wake up ID:

- ID = 0: No any handwriting gesture is detected.
- ID = 0xFF: Handwriting gesture detection is failure.
- ID = 0xB0: Left to right slide (→).
- ID = 0xB4: Right to left slide (←).
- ID = 0xB8: Top to down slide (↓).
- ID = 0xBC: Down to top slide (↑).
- ID = 0xC0: Double taps.

All character identifications are defined following ASCII code.

- ID = 0x63: c.
- ID = 0x65: e.
- ID = 0x6D: m.
- ID = 0x6F: o.
- ID = 0x73: s.
- ID = 0x76: v.
- ID = 0x77: w.
- ID = 0x7A: z.

9.9.16 Page Register

Reg. Addr.	Name	Bit 7	Bit 6	Bit 5	Bit 4	Bit 3	Bit 2	Bit 1	Bit 0
0xFF	Page Reg.	Page Number (RW)							

For ST1x56/ST1x64/ST1x64A/ST1x72 series touch IC:

The auto tune program is build-in into ST1x56/ST1x64/ST1x64A/ST1x72. Page Register provides changing page Of host Interface Register. Default page is Report Page.

Page Number	Description
0x00	Report Page
0x01	Auto Tune Page

For ST1x32/ST1x28/ST1x30/ST1x34/ST1x36/ST1x33i/ST1x33/ST1x24/ST1615/ST1912/ST1727/ST1727series touch IC: Page Register is a read only register. It can not change page by writing specified page number into this register.

9.10 Sample Codes

9.10.1 Data Structures and APIs

```
typedef struct {
    u8 y_h: 3,
    reserved: 1,
    x_h: 3,
    valid: 1;
    u8 x_l;
    u8 y_l;
    u8 z;
} xyz_data_t;
typedef struct {
    u8 fingers: 4,
    reserved: 4;
    u8 keys;
    xyz_data_t xyz_data[10];
} stx_report_data_t;
// I2C Master sends count bytes data stored in buf to I2C Slave.
// I2C package: | S | I2C Addr | W | Data (buf) | P |
extern int i2c_master_send(const char *buf, int count);
// I2C Master reads count bytes data to buf from I2C Slave.
// I2C package: | S | I2C Addr | R | Data (buf) | Nak | P |
extern int i2c_master_recv(char *buf, int count);
```

9.10.2 Get Version

```
static int get_fw_version(u32 *ver)
{
    u8 buf[1];
    int ret = 0;
    buf[0] = 0x0; // Set Reg. address to 0x0 for reading FW Version.
    if (ret = i2c_master_send(buf, 1))
        goto err;
    if (ret = i2c_master_recv(buf, 1)) // Read 1 byte FW Version from Reg. 0x0 set previously.
        goto err;
    *ver = (u32) buf[0]; // Return FW Version.
    buf[0] = 0x10; // Set Reg. address back to 0x10 for Coordinates.
    if (i2c_master_send(buf, 1))
        goto err;
    err:
    return ret;
}
```

9.10.3 Set Power Down (PD)

```
static int set_power_down()
{
    u8 buf[2];
    int ret = 0;
    buf[0] = 0x2; // Set Reg. address to 0x2 for Device Control Reg.
    buf[1] = 0xA; // Keep Gesture bit and set PD bit to enter Power Down.
    if (ret = i2c_master_send(buf, 2))
        goto err;
```

```
err:
return ret;
}
```

9.10.4 Read XY Coordinates

The function, `get_coordinates()`, reads XY Coordinate registers from I2C Slave, extracts XY information from data buffer and returns to upper layer. This function shall be called from ISR each time when host receives and INT from device.

```
static int get_coordinates(u8 *count, u32 *x0, u32 *y0, u32 *x1, u32 *y1)
{
u8 buf[42];
stx_report_data_t *pdata;
int ret = 0;
*count = 0; // Set point detected count to 0.
if (i2c_master_recv(buf, sizeof(buf)) // Read Coordinates from default Reg. address 0x10.
goto err;
pdata = (stx_report_data_t *) buf;
if (pdata->fingers) {
if (pdata->xy_data[0].valid) {
*x0 = pdata->xy_data[0].x_h << 8 | pdata->xy_data[0].x_l;
*y0 = pdata->xy_data[0].y_h << 8 | pdata->xy_data[0].y_l;
(*count)++;
}
if (pdata->xy_data[1].valid) {
*x1 = pdata->xy_data[1].x_h << 8 | pdata->xy_data[1].x_l;
*y1 = pdata->xy_data[1].y_h << 8 | pdata->xy_data[1].y_l;
(*count)++;
}
}
err:
return ret;
}
```

10. OPTICAL CHARACTERISTIC

Ta= 25°C

Parameter	Symbol	Condition	Min.	Typ.	Max.	Unit	Remarks
Viewing Angle	θ_L	Center CR \geq 10	70	80	-	deg	Note 1,2
	θ_R		70	80	-		
	θ_T		70	80	-		
	θ_B		70	80	-		
Contrast Ratio	CR	at optimized viewing angle	600	800	-		Note 1,4
Response time	Tr+Tf	Center $\theta_x=\theta_y=0^\circ$	-	25	-	ms	Note 1,6
Uniformity	B-uni	$\theta_x=\theta_y=0^\circ$	70	-	-	%	Note 1,5
Brightness	L	$\theta_x=\theta_y=0^\circ$	680	850	-	cd/m ²	Note 1,3
Chromaticity	W	x_W	Center $\theta_x=\theta_y=0^\circ$	Typ. -0.05	0.301	Typ. +0.05	Note 1,7
		y_W			0.338		
	R	x_R			0.561		
		y_R			0.316		
	G	x_G			0.303		
		y_G			0.527		
	B	x_B			0.143		
		y_B			0.169		

The following optical specifications shall be measured in a darkroom or equivalent state (ambient luminance \leq 1 lux, and at room temperature). The operation temperature is 25°C \pm 2°C and LED Backlight Current IF=130mA. The measurement method is shown in Note1.

Note 1: The method of optical measurement:

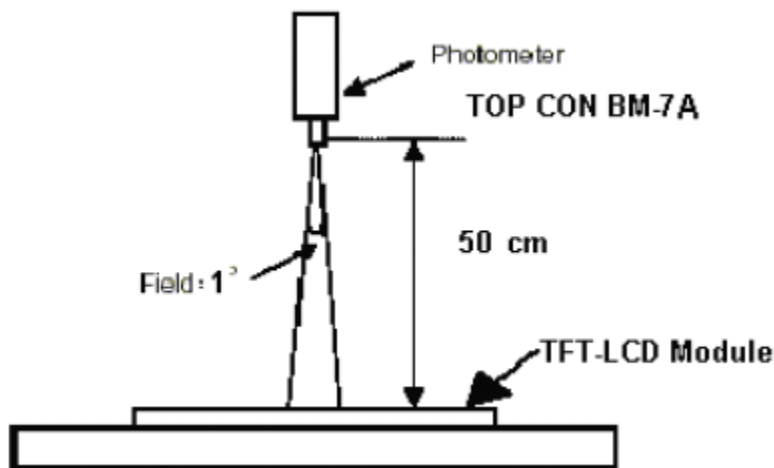

Note 2: Definition of viewing angle range

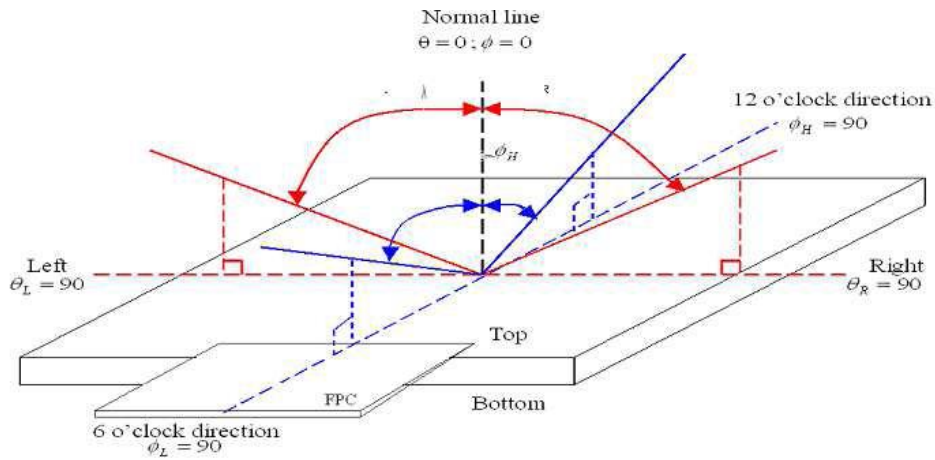

Note 3: Measured at the center area of the panel and at the viewing angle of the $\theta_x = \theta_y = 0^\circ$

Note 4: Definition of Contrast Ratio (CR):

$$CR = \frac{\text{Luminance with all pixels in white state}}{\text{Luminance with all pixels in Black state}}$$

Note 5: Definition of Brightness Uniformity (B-uni):

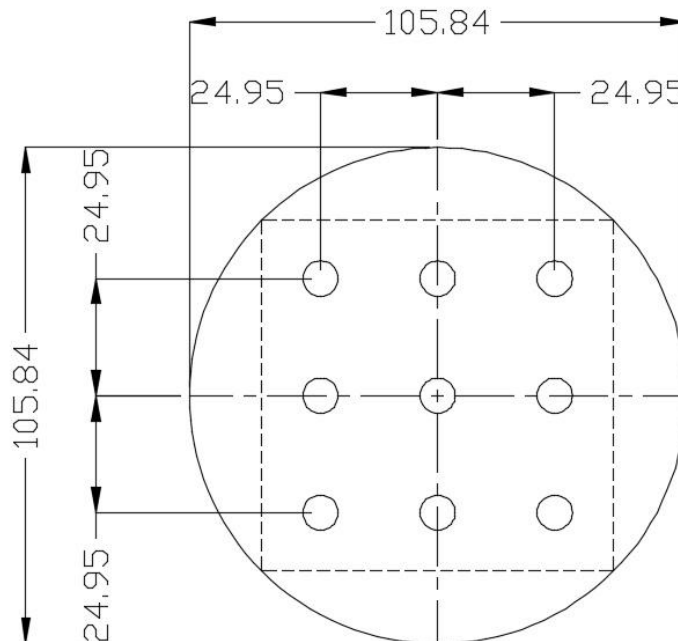

$$B\text{-uni} = \frac{\text{Minimum luminance of 9 points}}{\text{Maximum luminance of 9 points}} \quad (\text{Note 5}).$$

Note 6: Definition of Response Time:

The Response Time is set initially by defining the "Rising Time (T_r)" and the "Falling Time (T_f)" respectively. T_r and T_f are defined as following figure.

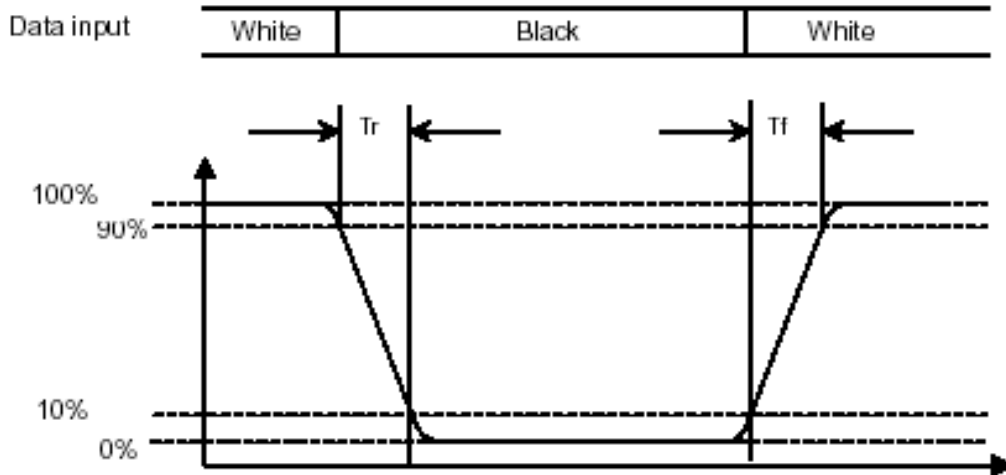

Note 7: The color coordinates (X_w, y_w), (X_R, y_R), (X_G, y_G), and (X_B, y_B) are obtained with all pixels in the viewing field at white, red, green, and blue states, respectively.

11. QUALITY ASSURANCE

11.1 Test Condition

11.1.1 Temperature and Humidity(Ambient Temperature)

Temperature : 20 ± 5°C

Humidity : 65 ± 5%

11.1.2 Operation

Unless specified otherwise, test will be conducted under function state.

11.1.3 Container

Unless specified otherwise, vibration test will be conducted to the product itself without putting it in a container.

11.1.4 Test Frequency

In case of related to deterioration such as shock test. It will be conducted only once.

11.1.5 Test Method

Reliability Test Item & Level			Remark
No.	Test Item	Test Level	
1	High Temperature Storage Test	Ta=85°C,240hrs	IEC0068-2-2
2	Low Temperature Storage Test	Ta=-30°C,240hrs	IEC0068-2-1
3	High Temperature Operation Test	Ta=85°C,240hrs	IEC0068-2-2
4	Low Temperature Operation Test	Ta=-30°C,240hrs	IEC0068-2-1
5	High Temperature and High Humidity (No operation)	T=60°C,90%RH,240hrs	IEC0068-2-3
6	Thermal Cycling Test (No operation)	-30°C → +25°C → +85°C ,30 Cycles 30 min 5 min 30 min	IEC0068-2-14
7	Vibration test (Package)	Frequency:10~55HZ Amplitude:1.5mm Sweep time:11min Test period:6Cycles for each direction of X,Y,Z	IEC0068-2-6
8	Drop test (Package)	Height :60cm 1 conner,3edges,6surfaces	IEC0068-2-32
9	Electrostatic Discharge Test	Location: LCM/TP surface Condition:150pf 330Ω Contact +/- 4kV Air +/-8kV Criteria: Class C	IEC61000-4-2

12. APPEARANCE SPECIFICATION

12.1 Inspection condition

12.1.1 Inspection conditions

12.1.1.1 Inspection Distance : 35 ± 5 cm

12.1.1.2 View Angle :

- (1) Inspection under operating condition : $\pm 5^\circ$
- (2) Inspection under non-operating condition : $\pm 45^\circ$

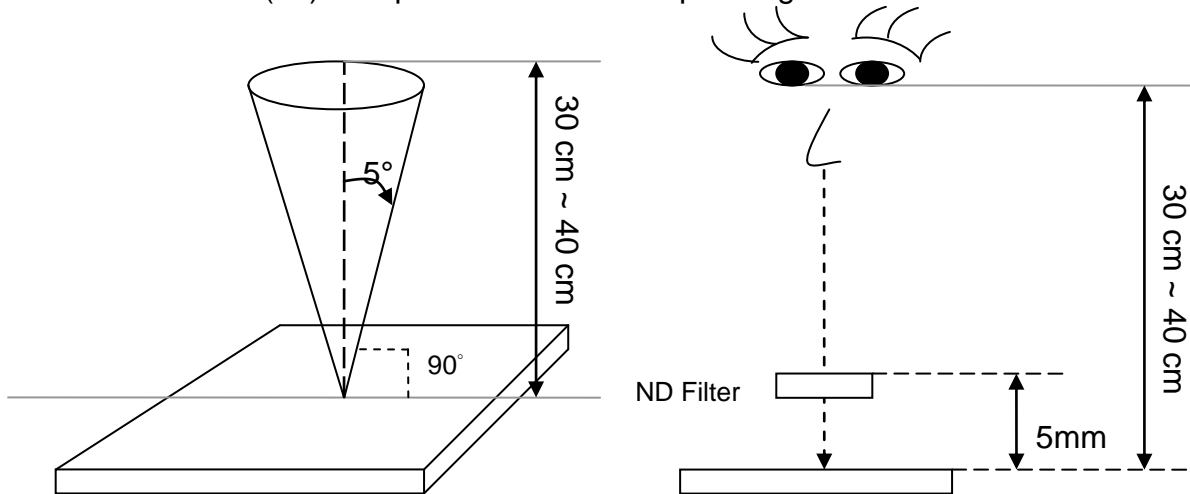

12.1.2 Environment conditions:

Ambient Temperature :	$25 \pm 5^\circ\text{C}$
Ambient Humidity :	30~70%RH
Ambient Illumination	600~800 lux

12.2 Inspection Parameters

Appearance inspection standard (D: diameter, L: length; W: width, Z: height, T: glass thickness)

Inspection item	Inspection standard			Description
No image	Prohibited			
Image abnormal	Prohibited			
Bright line	Prohibited			
Mura	It is acceptable that the defect can not be seen with 2% ND filter.			
Dot	Item	Acceptable Visible area	Total	
	Bright dot	2	6	
	Dark dot	4		
	Bright adjacent dots	2	2	
	Dark adjacent dots	2	2	
	Adjacent dots with a bright dot and a dark dot	0	0	

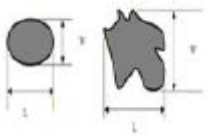
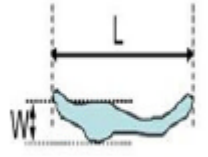
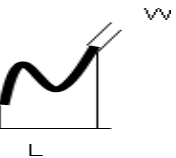
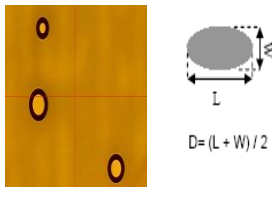
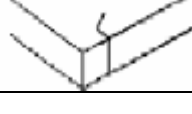
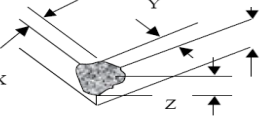
Foreign material in dot shape	SPEC (unit: mm)	Acceptable	 <p>$D = (L + W) / 2$</p>
	$D \leq 0.3$	Ignored	
	$0.3 < D \leq 0.5$, distance > 5	$n \leq 5$	
	$D > 0.5$	0	
Foreign material in line shape	SPEC	Acceptable	 <p>L : Long W : Width</p>
	$W \leq 0.05$ and $L \leq 7$	Ignored	
	$0.05 < W \leq 0.1$, $L \leq 7$, distance > 5	$n \leq 5$	
	$W > 0.1$ or $L > 7$	0	
Contamination	It is acceptable if the dirt can be wiped.		
Scratch	SPEC	Acceptable	
	$W \leq 0.05$ and $L \leq 10$	Ignored	
	$0.05 < W \leq 0.08$, $L \leq 10$, distance > 5	$n \leq 5$	
	$0.08 < W \leq 0.1$, $L \leq 10$, distance > 5	$n \leq 5$	
	$W > 0.1$ or $L > 10$	0	
Bubble	SPEC (unit: mm)	Acceptable	 <p>$D = (L + W) / 2$</p>
	$D \leq 0.2$	Ignored	
	Non visible area	Ignored	
	$0.2 < D \leq 0.3$, distance > 5	$n \leq 5$	
	$D > 0.3$	0	
Cover & Sensor Crack	Prohibited		
Cover angle missing	SPEC (unit: mm)	Acceptable	
	Side/Bottom	Ignored	
	$Y \leq 2.0$	0	

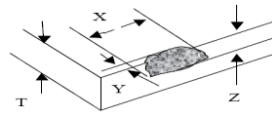
Inspection item	SPEC		Description
Cover edge break	SPEC (unit: mm)	Acceptable	
	$X \leq 2.0, Y \leq 2.0, Z \leq 1/2T$	Ignored	
	$X > 2.0, Y > 2.0, Z > 1/2T$	0	
Ink	SPEC (unit: mm)	Acceptable	
	word unclear, inverted, mistake, break line	0	
Bubble under protection film	SPEC (unit: mm)	Acceptable	
	NA		
Function	Prohibited		

12.3 Sampling Condition

Unless otherwise agree in written, the sampling inspection shall be applied to the incoming inspection of customer.

Lot size: Quantity of shipment lot per model.

Sampling type: normal inspection, single sampling

Sampling table: ISO 2859

Inspection level: Level II

Class of defects	Definition		
	Major	AQL 0.65	It is a defect that is likely to result in failure or to reduce materially the usability of the product for the intended function.
	Minor	AQL 1.5	It is a defect that will not result in functioning problem with deviation classified.



13. PRODUCT LABEL DEFINE

Product Label style:

TBD

14. PRECAUTIONS IN USE LCM

1. ASSEMBLY PRECAUTIONS

- (1) You must mount a module using holes arranged in four corners or four sides.
- (2) You should consider the mounting structure so that uneven force (ex. Twisted stress) is not applied to the module. And the case on which a module is mounted should have sufficient strength so that external force is not transmitted directly to the module.
- (3) Do not touch, push or rub the exposed polarizers with glass, tweezers or anything harder than HB pencil lead. And please do not rub with dust clothes with chemical treatment.
- (4) Wipe off saliva or water drops as soon as possible. Their long time contact with polarizer causes deformations and color fading.
- (5) Do not open the case because inside circuits do not have sufficient strength.
- (6) Please do not take a LCD module to pieces and reconstruct it. Resolving and reconstructing modules may cause them not to work well.
- (7) Please do not touch metal frames with bare hands and soiled gloves. A color change of the metal frames can happen during a long preservation of soiled LCD modules.
- (8) Please pay attention to handling lead wire of backlight so that it is not tugged in connecting with inverter.

2. OPERATING PRECAUTIONS

- (1) Please be sure to turn off the power supply before connecting and disconnecting signal input cable.
- (2) Please do not change variable resistance settings in LCD module. They are adjusted to the most suitable value. If they are changed, it might happen LCD does not satisfy the characteristics specification
- (3) Be careful for condensation at sudden temperature change. Condensation makes damage to polarizer or electrical contacted parts. And after fading condensation, smear or spot will occur.
- (4) When fixed patterns are displayed for a long time, remnant image is likely to occur.
- (5) Module has high frequency circuits. Sufficient suppression to the electromagnetic interference shall be done by system manufacturers. Grounding and shielding methods may be important to minimize the interference.
- (6) Please consider that LCD backlight takes longer time to become stable of radiation characteristics in low temperature than in room temperature.

3. ELECTROSTATIC DISCHARGE CONTROL

The operator should be grounded whenever he/she comes into contact with the module. Never touch any of the conductive parts such the copper leads on the PCB and the interface terminals with any parts of the human body.

- (2) The modules should be kept in antistatic bags or other containers resistant to static for storage.
- (3) Only properly grounded soldering irons should be used.
- (4) If an electric screwdriver is used, it should be well grounded and shielded from commutator sparks.
- (5) The normal static prevention measures should be observed for work clothes and working benches; for the latter conductive (rubber) mat is recommended
- (6) Since dry air is inductive to statics, a relative humidity of 50-60% is recommended.

4. STORAGE PRECAUTIONS

- (1) When you store LCDs for a long time, it is recommended to keep the temperature between 0°C-40°C without the exposure of sunlight and to keep the humidity less than 90%RH.
- (2) Please do not leave the LCDs in the environment of high humidity and high temperature such as 60°C 90%RH
- (3) Please do not leave the LCDs in the environment of low temperature; below -20°C.

5. OTHERS

- (1) A strong incident light into LCD panel might cause display characteristics' changing inferior because of polarizer film, color filter, and other materials becoming inferior. Please do not expose LCD module direct sunlight and strong UV rays
- (2) Please pay attention to a panel side of LCD module not to contact with other materials in preserving it alone.
- (3) For the packaging box, please pay attention to the followings:
 - a. Please do not pile them up more than 5 boxes. (They are not designed so.) And please do not turn over.
 - b. Please handle packaging box with care not to give them sudden shock and vibrations. And also please do not throw them up.
 - c. Packing box and inner case for LCDs are made of cardboard. So please pay attention not to get them wet. (Such like keeping them in high humidity or wet place can occur getting them wet.)
- (4) Waste
Liquid crystal module products shall not be arbitrarily discarded; the water and soil have a negative impact on the environment, the need to be handled by a qualified unit.

6. LIMITED WARRANTY

Unless otherwise agreed between TSD and customer, TSD will replace or repair any of its LCD and LCM which is found to be defective electrically and visually when inspected in accordance with TSD acceptance standards, for a period on one year from date of shipment. Confirmation of such date shall be based on freight documents. The warranty liability of TSD is limited to repair and/or replacement on the terms set forth above. TSD will not responsible for any subsequent or consequential events.

15. OUTLINE DRAWING

PRELIMINARY

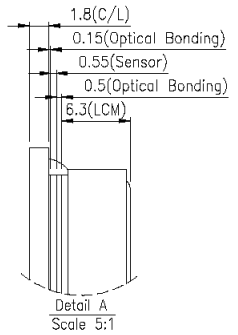
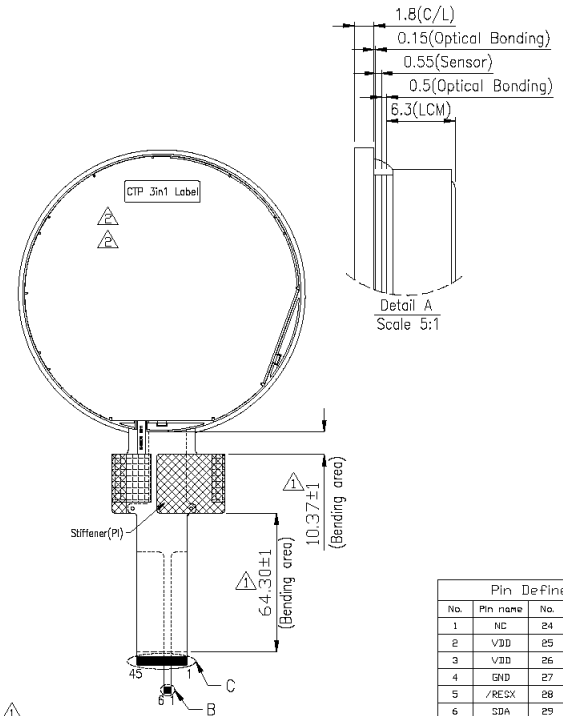
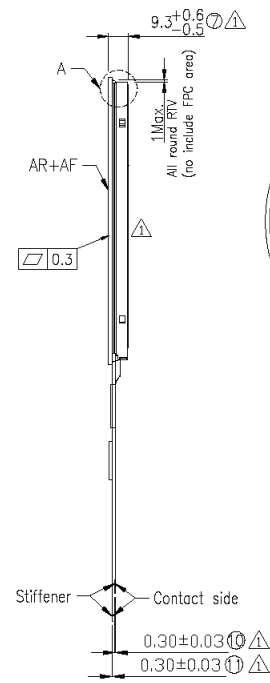
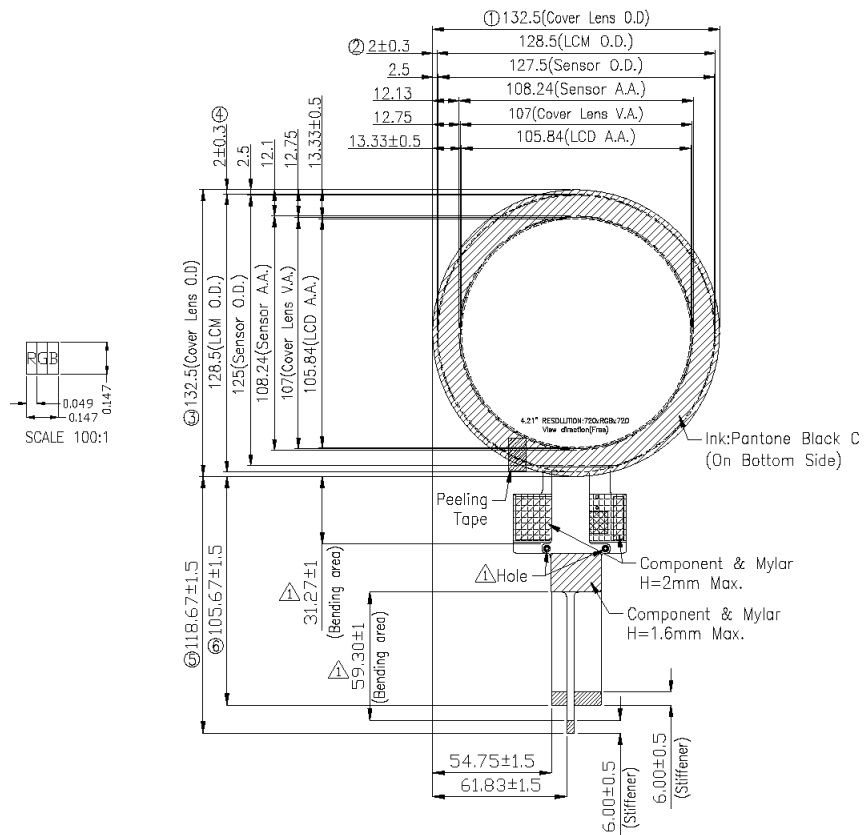

Pin Define			
No.	Pin name	No.	Pin name
1	NC	24	DB8
2	VDD	25	DB9
3	VDD	26	DB10
4	GND	27	DB11
5	/RESX	28	DB12
6	SDA	29	DB13
7	NC	30	DB14
8	SCL	31	DB15
9	CSX	32	GND
10	DCLK	33	DB16
11	DE	34	DB17
12	VSYNC	35	DB18
13	HSYNC	36	DB19
14	GND	37	DB20
15	DB0	38	DB21
16	DB1	39	DB22
17	DB2	40	DB23
18	DB3	41	GND
19	DB4	42	LEDA
20	DB5	43	LEDB
21	DB6	44	LEDC
22	DB7	45	LEDC
23	GND		

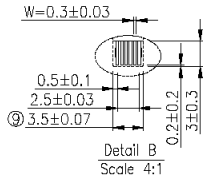
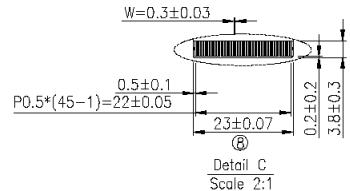
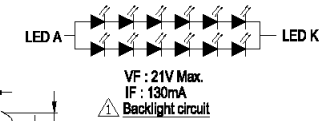

- Note:
- Tolerance is ±0.3 unless otherwise noted.
 - LCM FPC matching connector: MOLEX 54132-4562 or equivalent.
 - CTP FPC matching connector: MOLEX 51548-0671 or equivalent.
 - For RoHS & REACH.
 - Center brightness : 850 cd/m²(Typ.) 680cd/m² (Min.).
 - Uniformity : 70%. (Min)
 - Important dimension. ①~⑪
 - CTP IC : Sitronix ST1727

AUTH	DESCRIPTION	DATE	APPROVED	DATE:	2018/02/01	TITLE:	CTP OUTLINE DIMENSION		
	Remove LCM - UL label. (ECR110-I90021)	2018/09/14		DRAWN:		DWG. NO.			
	Cancel 10.94Max dimension mark. Modify tolerance from 9.3±0.5 to 9.3+0.6/-0.5 (ECR 11S-I50009)	2018/05/17		CHCK:		UNITS	M M	REV.	3
	Modify LCM design. Add important dimensions 10,11 & backlight circuit. (ECR 11S-I50009)	2018/05/17		APPROVE:		SCALE	Scale	SHBET 1 OF 1	
	Modify CTP & LCM FPC outline. Add CTP & LCM FPC bending area dimensions & hole. (ESR0612006)	2018/05/17							
REVISIONS									



16. PACKAGE INFORMATION

TBD