

General Description

The SY28876A smart switch is a highly integrated circuit and power management device with a full suite of protection functions, including a low-power device sleep (DevSleep) mode. Its wide operating input voltage range of 2.7V to 18V makes it ideal for the control of many popular DC BUS voltages in SSD applications.

Integrated back-to-back MOSFETs provide bidirectional current control, making the device well-suited for systems with load-side energy reservoirs that must not drain back to a failed supply BUS.

The device provides many programmable features, including overcurrent, dV_o/dt ramp, overvoltage, and undervoltage thresholds using very few external components. The device provides PGOOD, /FLT and precise current monitor outputs for system status monitoring and downstream load control. Precise programmability and the low I_Q DevSleep mode simplify SSD power management design.

The SY28876A provides true reverse current blocking by monitoring $V_{IN} < (V_{OUT} - 25mV)$. This function supports swift change over to a boosted voltage energy storage element in systems with higher backup voltage than the BUS voltage.

Features

- 2.7V to 18V Operating Voltage, 30V (Max)
- Ultra Low $R_{DS(ON)}$: 42 mΩ R_{ON} (Typical)
- 0.6A to 5.3A Adjustable Current Limit ($\pm 8\%$)
- IMON Current Indicator Output ($\pm 8\%$)
- Operating I_Q : 115 μA ($V_{IN} = 12 V$, typ.)
- Shutdown Current: 15 μA ($V_{IN} = 12 V$, typ.)
- Reverse Current Blocking
- Programmable dV/dt Control
- Power Good and Fault Outputs
- $-40^\circ C$ to $125^\circ C$ Junction Temperature Range
- QFN3x4-20 Package
- UL Certificate Number: E491480

Applications

- PCIe/SATA/SAS HDD and SSD Drives
- Enterprise and Micro Servers
- Set-Top-Box (STB), DTVs and Game Consoles
- RAID Cards - Holdup Power Management
- Telecom Switches and Routers
- Adapter Powered Devices

Typical Application

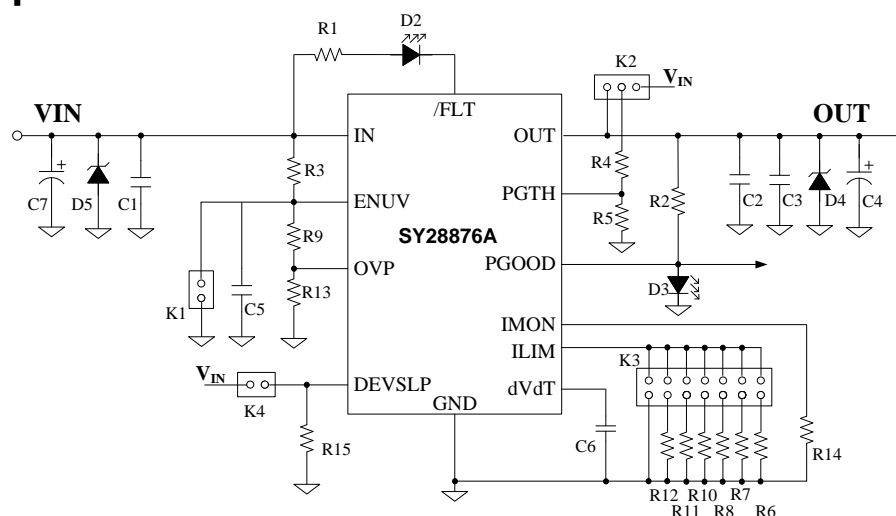

Figure 1. Schematic Diagram

Ordering Information

Ordering Part Number	Package Type	Top Mark
SY28876AQSC	QFN3x4-20 RoHS Compliant and Halogen Free	CEGxyz

Device code: CEG

x=year code, y=week code, z= lot number code

Pinout (Top View)

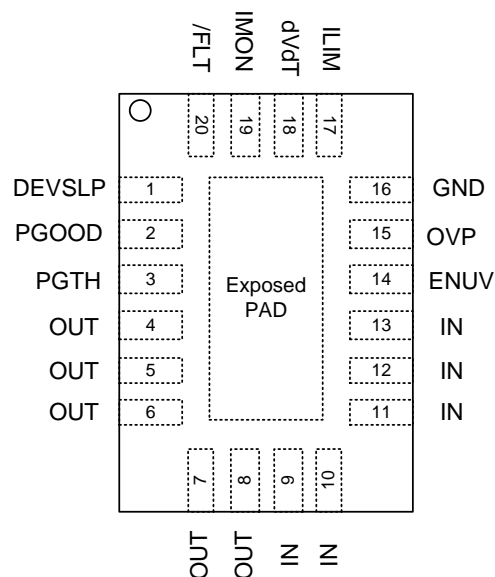

Pin Name	Pin NO.	I/O	Pin Description
DEVSLP	1	I	Active High. DevSleep mode control. A high at this pin will activate the DevSleep mode (Low Power mode).
PGOOD	2	O	Active High. A high indicates PGTH has crossed the threshold value. It is an open-drain output.
PGTH	3	I	Positive input of PGOOD comparator.
OUT	4-8	O	Power Output of the device.
IN	9-13	I	Power Input and supply voltage of the device.
ENUV	14	I	Input for setting programmable under voltage lockout threshold. An undervoltage event will open internal MOSFET and assert /FLT to indicate power-failure.
OVP	15	I	Input for setting programmable overvoltage protection threshold. An overvoltage event will open the internal MOSFET and assert /FLT to indicate overvoltage.
GND	16	-	Ground pin.
ILIM	17	I/O	A resistor from this pin to GND sets the overload and short-circuit current limit.
dVdT	18	I/O	A capacitor from this pin to GND sets the ramp rate of output voltage.
IMON	19	O	This pin sources a scaled down ratio of current through the internal FET. A resistor from this pin to GND converts current to proportional voltage, used as analog current monitor.
/FLT	20	O	Fault event indicator -driven low to indicate a fault condition due to undervoltage, overvoltage, reverse voltage and thermal shutdown events. It is an open drain output.
Exposed pad	-		The GND terminal must be connected to the exposed PAD. This exposed PAD must be connected to a PCB ground plane using multiple vias for good thermal performance.

Block Diagram

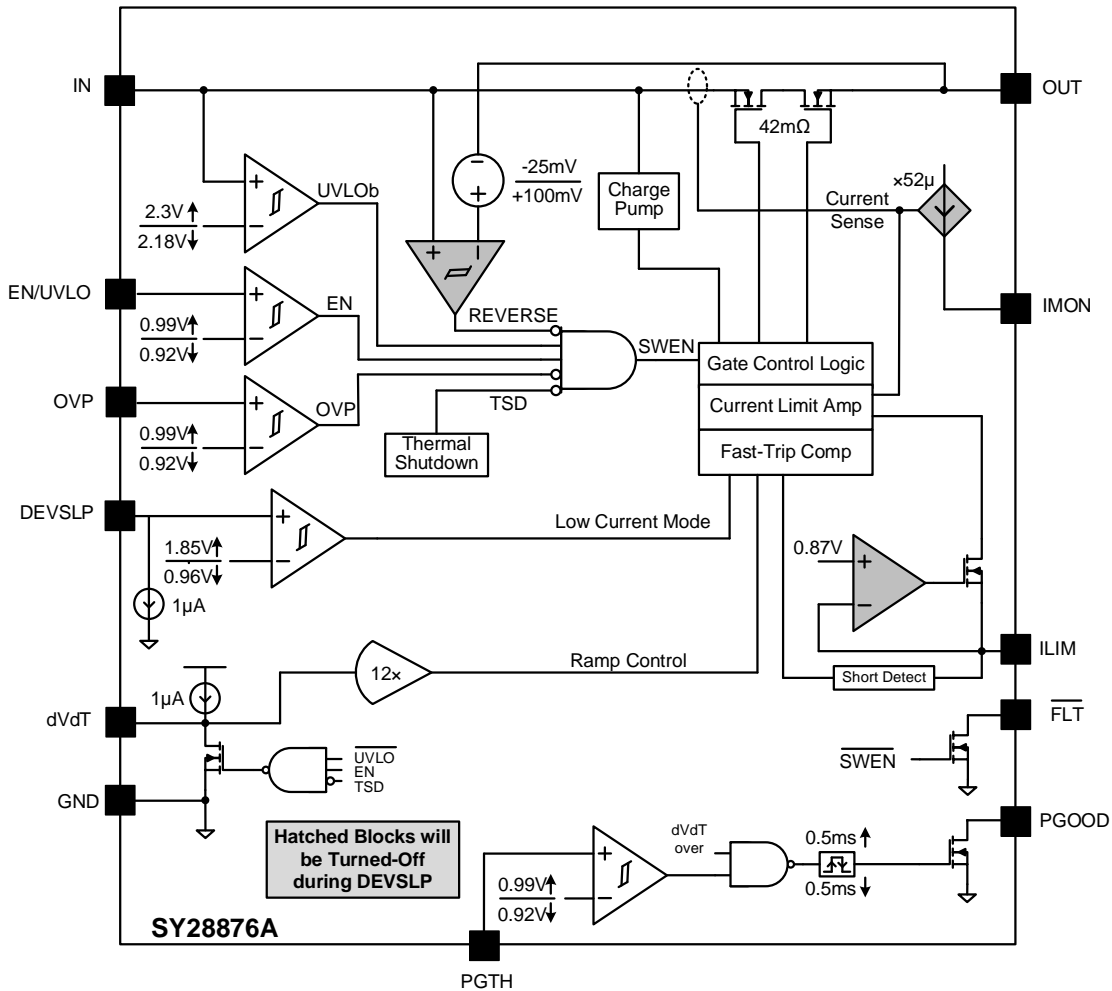

Figure 2. Block Diagram

Absolute Maximum Ratings

Parameter (Note 1)	Min	Max	Unit
IN, PGTH, PGOOD, ENUV, OVP, DEVSLP, /FLT	-0.3	30	V
OUT	-1	20	
dVdT, ILIM, IMON	-0.3	7	
PGOOD, /FLT, dVdT Sink Current		10	mA
Lead Temperature (Soldering, 10s)		260	°C
Junction Temperature, Operating	-40	150	
Storage Temperature	-65	150	

Thermal Information

Parameter (Note 2)	Typ	Unit
θ_{JA} Junction-to-Ambient Thermal Resistance	31.5	°C/W
θ_{JC} Junction-to-Case Thermal Resistance	26	
P_D Power Dissipation $T_A = 25^\circ\text{C}$	3.17	W

Recommended Operating Conditions

Parameter (Note 3)	Min	Max	Unit
IN	2.7	18	V
OUT, PGTH, PGOOD, ENUV, OVP, DEVSLP, /FLT	0	18	
dVdT, ILIM, IMON	0	6	
R _{ILIM}	16.9	150	kΩ
R _{IMON}	1		kΩ
C _{OUT}	0.1		μF
C _{dVdT}		470	nF
Junction Temperature, Operating	-40	125	°C
Ambient Temperature	-40	105	

Electrical Characteristics

(-40°C ≤ T_J=T_A ≤ 125°C, 2.7V ≤ V_{IN} = 18V, V_{EN/UVLO} = 2V, V_{OVP} = V_{DEVSLP} = V_{PGTH} = 0V, R_{ILIM} = 150kΩ, C_{OUT} = 1μF, C_{dVdT} = OPEN, PGOOD = /FLT = IMON = OPEN. Positive current reaches terminals. All voltages referenced to GND, unless otherwise specified. The values are guaranteed by test, design, or statistical correlation.)

Parameter	Symbol	Test Conditions	Min	Typ	Max	Unit
Supply Voltage and Internal Under Voltage Lockout						
Input Voltage Range	V _{IN}		2.7		18	V
Input UVLO Threshold	V _{UVLO}		2.2	2.3	2.4	V
UVLO Hysteresis	V _{HYS}		112	122	132	mV
Shutdown Current	I _{SHDN}	V _{EN/UVLO} = 0 V, V _{IN} = 3 V	3	8.6	15	μA
		V _{EN/UVLO} = 0 V, V _{IN} = 12 V	3	15	20	
		V _{EN/UVLO} = 0 V, V _{IN} = 18 V	3	18.5	25	
Quiescent Current	I _Q	V _{EN/UVLO} = 2 V, V _{IN} = 3 V	60	110	160	μA
		V _{EN/UVLO} = 2 V, V _{IN} = 12 V	65	115	165	
		V _{EN/UVLO} = 2 V, V _{IN} = 18 V	65	115	165	
DevSleep Mode Current	I _{Q_DEVSLP}	V _{DEVSLP} = 0 V, V _{IN} = 2.7V to 18V	60	100	140	μA
Enable And Under Voltage Lockout (En/UVLO) Input						
EN/UVLO Logic High	V _{ENH}		0.97	0.99	1.01	V
EN/UVLO Logic Low	V _{ENL}		0.9	0.92	0.94	V
EN Threshold Voltage for Low I _Q Shutdown, Falling	V _{SHUTF}		0.3	0.47	0.63	V
EN Hysteresis for Low I _Q Shutdown				66		mV
EN Input Leakage Current	I _{EN}	0 V ≤ V _{EN/UVLO} ≤ 18 V	-100	0	100	nA
Over Voltage Protection (OVP) Input						
Overvoltage Threshold Voltage, Rising.	V _{OVPR}		0.97	0.99	1.01	V
Overvoltage Threshold Voltage, Falling.	V _{OVPF}		0.9	0.92	0.94	V
OVP Input Leakage Current	I _{OVP}	0 V ≤ V _{OVP} ≤ 5 V	-100	0	100	nA
Devslp Mode Input (Devslp): Active High						
DEVSLP Threshold Voltage, Rising.	V _{DEVSLPR}		1.6	1.85	2	V
DEVSLP Threshold Voltage, Falling.	V _{DEVSLPF}		0.8	0.96	1.1	V
DEVSLP Input Leakage Current	I _{DEVSLP}	0.2 V ≤ V _{DEVSLP} ≤ 18 V	0.6	1	1.25	μA
Output Ramp Control (dVdT)						

Parameter	Symbol	Test Conditions	Min	Typ	Max	Unit
dVdT Charging Current	I _{dVdT}	V _{dVdT} = 0 V	0.85	1	1.15	μA
dVdT Discharging Resistance	R _{dVdT}	V _{EN/UVLO} = 0V, I _{dVdT} = 10mA sinking		16	35	Ω
dVdT to OUT Gain	G _{dVdT}	ΔV _{OUT} /ΔV _{dVdT}	11.65	11.9	12.05	V/V
MOSFET – Power Switch						
IN to OUT - ON Resistance	R _{DS(ON)}	1A ≤ I _{OUT} ≤ 5A, T _J = 25°C	34	42	49	mΩ
		1A ≤ I _{OUT} ≤ 5A, -40°C ≤ T _J ≤ 85°C	26		58	
		1A ≤ I _{OUT} ≤ 5A, -40°C ≤ T _J ≤ 125°C	26		66	
CURRENT LIMIT PROGRAMMING (ILIM)						
ILIM Bias Voltage	V _{ILIM}			0.87		V
Current Limit	I _{LIM}	R _{LIM} = 150 kΩ, (V _{IN} - V _{OUT}) = 1V	0.53	0.58	0.63	A
		R _{LIM} = 88.7 kΩ, (V _{IN} - V _{OUT}) = 1V	0.9	0.99	1.07	
		R _{LIM} = 42.2 kΩ, (V _{IN} - V _{OUT}) = 1V	1.92	2.08	2.25	
		R _{LIM} = 24.9 kΩ, (V _{IN} - V _{OUT}) = 1V	3.25	3.53	3.81	
		R _{LIM} = 20 kΩ, (V _{IN} - V _{OUT}) = 1V	4.09	4.45	4.81	
		R _{LIM} = 16.9 kΩ, (V _{IN} - V _{OUT}) = 1V	4.78	5.2	5.62	
		R _{LIM} = OPEN	0.35	0.45	0.55	
R _{LIM} = SHORT	0.55	0.67	0.8			
DevSleep Mode Current Limit	I _{DEVSLP(LIM)}		0.55	0.67	0.8	A
Short-circuit Current Limit	I _{OS}	R _{LIM} = 42.2 kΩ, V _{IN} =12V, (V _{IN} - V _{OUT}) = 5V	1.91	2.07	2.24	A
		R _{LIM} = 24.9 kΩ, V _{IN} =12V, (V _{IN} - V _{OUT}) = 5V	3.21	3.49	3.77	
		R _{LIM} = 16.9 kΩ, V _{IN} =12V, (V _{IN} - V _{OUT}) = 5V, -40°C ≤ T _J ≤ 85°C	4.7	5.11	5.52	
Fast-Trip Comparator Threshold	I _{FASTRIIP}		1.4 × I _{LIM} +2			A
Current Monitor Output (IMON)						
Gain Factor I _{MON} /I _{OUT}	G _{IMON}	1 A ≤ I _{OUT} ≤ 5 A	47.78	52.3	57.23	μA/A
Pass MOSFET Output (OUT)						
OUT Leakage Current in OFF State	I _{LKG_OUT}	V _{IN} = 18V, V _{EN/UVLO} = 0V, V _{OUT} = 0V (Sourcing)	-2	0	2	μA
		V _{IN} = 2.7V, V _{EN/UVLO} = 0V, V _{OUT} = 18V (Sinking)	3	13	20	
V _{IN} -V _{OUT} Threshold for Reverse Protection Comparator, Falling	V _{REVTH}		-40	-25	-10	mV
V _{IN} -V _{OUT} Threshold for Reverse Protection Comparator, Rising	V _{FWDTH}		84	100	116	mV
FAULT FLAG (/FLT): ACTIVE LOW						
/FLT Internal Pull-Down Resistance	R _{/FLT}	V _{OVP} = 2 V, I _{/FLT} = 5 mA sinking	15	30	55	Ω
/FLT Input Leakage Current	I _{/FLT}	0V ≤ I _{/FLT} ≤ 18V	-1	0	1	μA
POSITIVE INPUT for POWER-GOOD COMPARATOR (PGTH)						
PGTH Threshold Voltage, Rising	V _{PGTHR}		0.97	0.99	1.01	V
PGTH Threshold Voltage, Falling	V _{PGTHF}		0.9	0.92	0.94	V
PGTH Input Leakage Current	I _{PGTH}	0 V ≤ V _{PGTH} ≤ 18 V	-100	0	100	nA
POWER-GOOD COMPARATOR OUTPUT (PGOOD): ACTIVE HIGH						
PGOOD Internal Pull-down Resistance	R _{PGOOD}	V _{PGTH} = 0V, I _{PGOOD} = 5 mA sinking	15	30	55	Ω
PGOOD input leakage current	I _{PGOOD}	0 V ≤ V _{PGOOD} ≤ 18 V	-1	0	1	μA
THERMAL SHUT DOWN (TSD)						

Parameter	Symbol	Test Conditions	Min	Typ	Max	Unit
TSD Threshold	T_{TSD}			160		°C
TSD Hysteresis	T_{TSDhys}			12		°C
OVERVOLTAGE PROTECTION INPUT (OVP)						
OVP Disable Delay	$t_{OVP(dly)}$	OVP↑ (100mV above V_{OVP}) to /FLT↓		2		μs
Enable and UVLO Input						
EN Turn ON Delay	$t_{ON(dly)}$	EN/UVLO↑ (100mV above V_{ENR}) to $V_{OUT} = 100$ mV, $C_{dVdT} < 0.8$ nF		220		μs
		EN/UVLO↑ (100mV above V_{ENR}) to $V_{OUT} = 100$ mV, $C_{dVdT} \geq 0.8$ nF		$100 + 150 \times C_{dVdT}$		μs
EN Turn OFF Delay	$t_{OFF(dly)}$	EN/UVLO↓ (100mV below V_{ENF}) to /FLT↓		2		μs
Output Ramp Control (dV/dT)						
Output Ramp Time	t_{dVdT}	EN/UVLO ↑ to $V_{OUT} = 4.5$ V, with $C_{dVdT} = \text{open}$		0.2		ms
		EN/UVLO ↑ to $V_{OUT} = 11$ V, with $C_{dVdT} = \text{open}$	0.25	0.37	0.5	
		EN/UVLO ↑ to $V_{OUT} = 11$ V, with $C_{dVdT} = 1$ nF		0.97		
Current Limit						
Fast-Trip Comparator Delay	$t_{FAST RIP(dly)}$	$I_{OUT} > I_{FAST RIP}$		200		ns
Reverse Protection Comparator						
Reverse Protection Comparator Delay	$t_{REV(dly)}$	$(V_{IN} - V_{OUT}) \downarrow$ (1 mV overdrive below V_{REVTH}) to /FLT↓		10		μs
		$(V_{IN} - V_{OUT}) \downarrow$ (10 mV overdrive below V_{REVTH}) to /FLT↓		1		
	$t_{FWD(dly)}$	$(V_{IN} - V_{OUT}) \uparrow$ (10 mV overdrive below V_{FWDTH}) to /FLT↑		3.1		
Power-Good Comparator Output (PGOOD): Active High						
PGOOD Delay (De-glitch) Time	t_{PGOODR}	Rising edge	0.42	0.54	0.66	ms
	t_{PGOODF}	Falling edge	0.42	0.54	0.66	ms
Thermal Shut Down (TSD)						
Retry Delay in TSD				128		ms

Note 1: Stresses beyond the “Absolute Maximum Ratings” may cause permanent damage to the device. These are stress ratings only. Functional operation of the device at these or any other conditions beyond those indicated in the operational sections of the specification is not implied. Exposure to absolute maximum rating conditions for extended periods may affect device reliability.

Note 2: θ_{JA} is measured in the natural convection at $T_A = 25^\circ\text{C}$ on a high effective four-layer thermal conductivity test board of JESD5-2, -5, -7 thermal measurement standards.

Note 3: The device is not guaranteed to function outside its operating conditions.

Typical Performance Characteristics

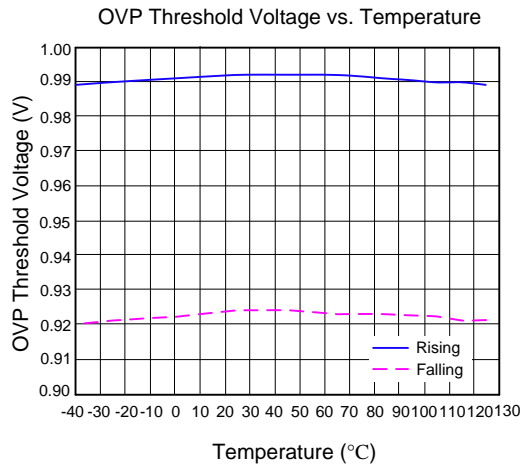
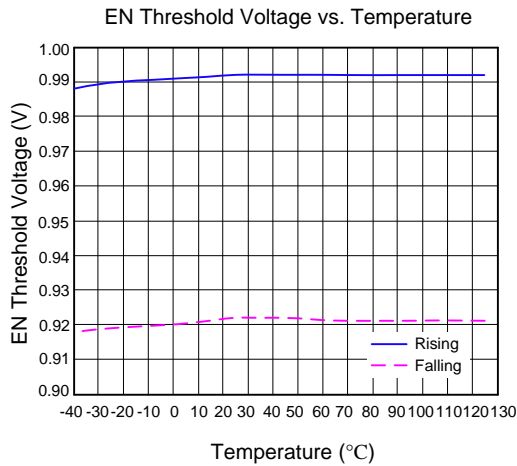
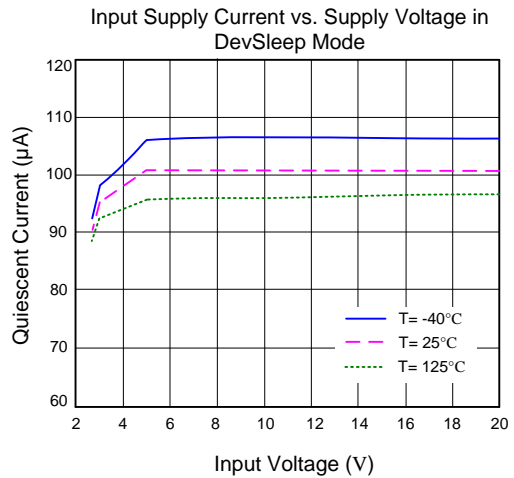
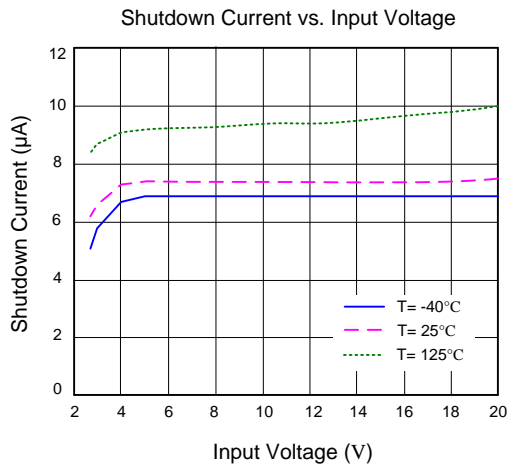
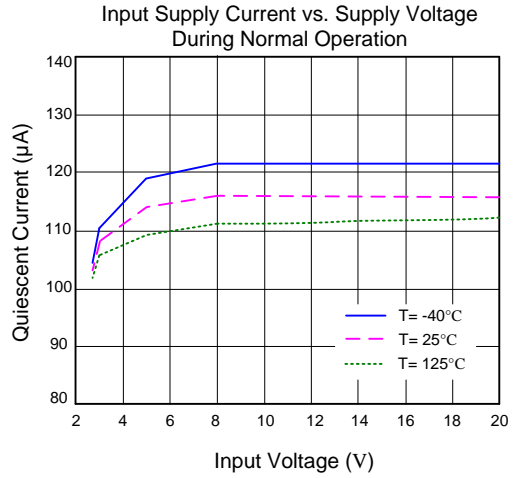
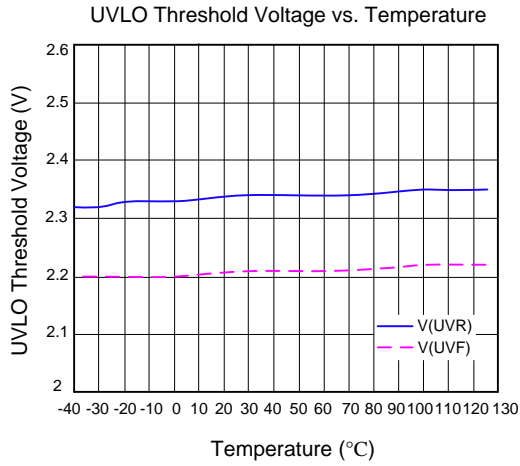

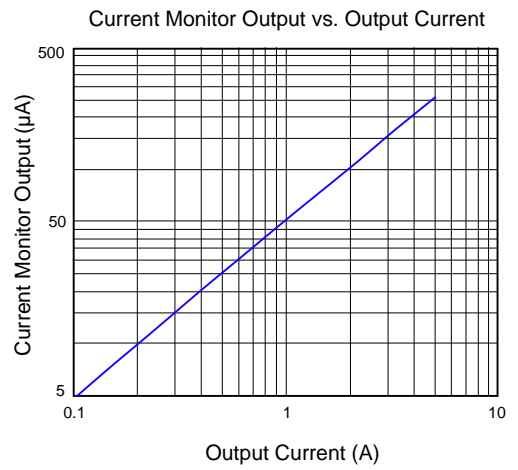
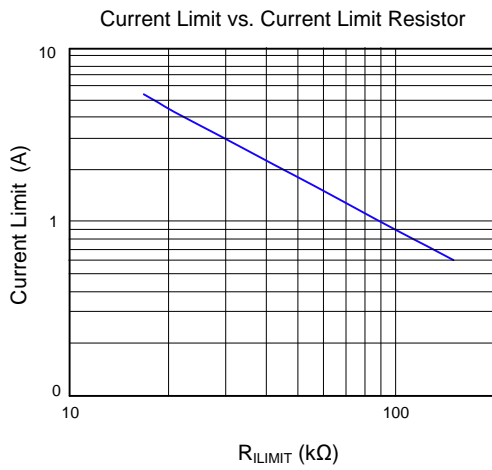
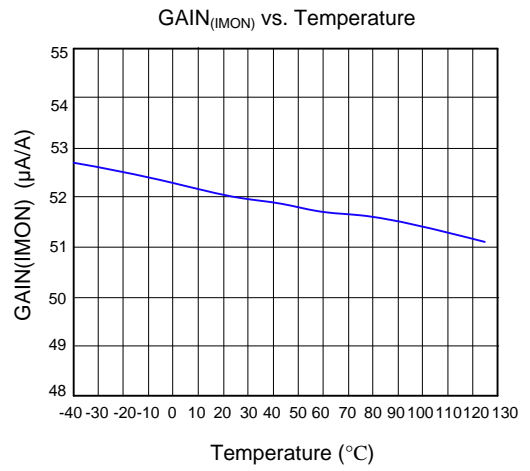
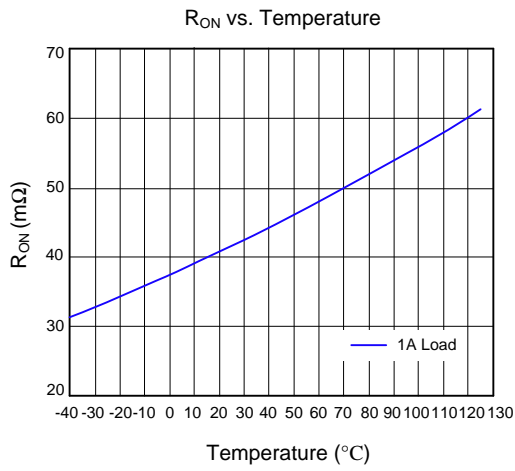
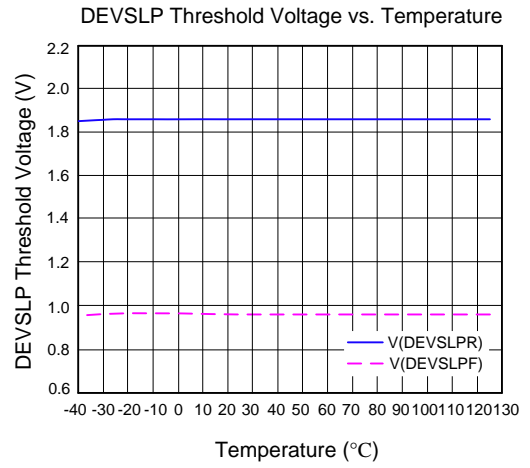
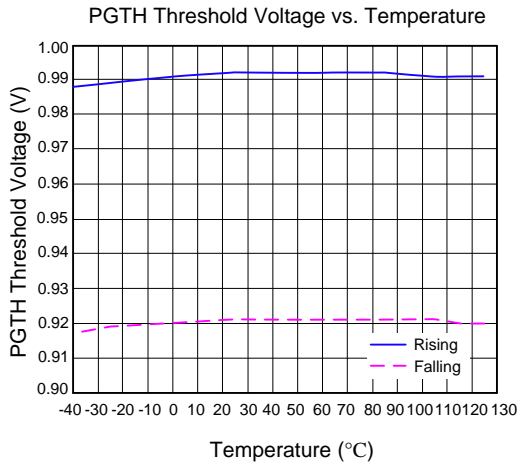

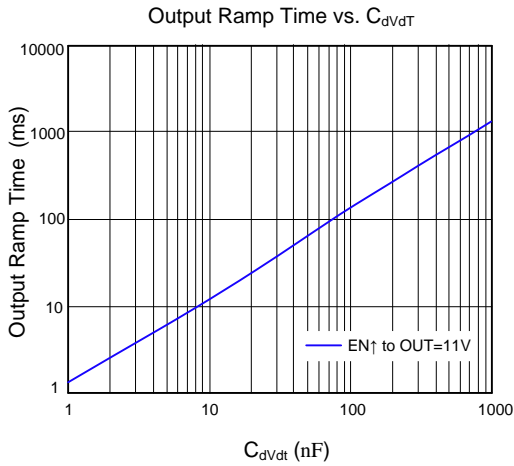

Hard-short: Auto-retry and Recovery from Short ($V_{IN}=18V$, $C_{IN}=C_{OUT}=10\mu F$, $R_{LIM}=16.9k\Omega$)

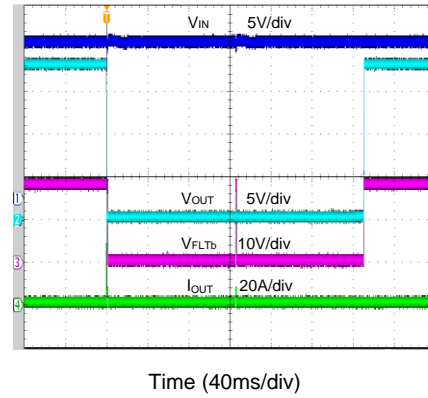

Turn ON with Enable ($V_{IN}=18V$, $C_{dVdt}=1nF$, $C_{OUT}=100\mu F$, 6 Ω Load)

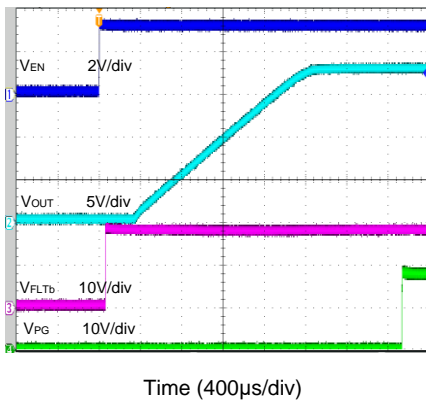

Turn OFF with Enable ($V_{IN}=18V$, $C_{dVdt}=1nF$, $C_{OUT}=100\mu F$, 6 Ω Load)

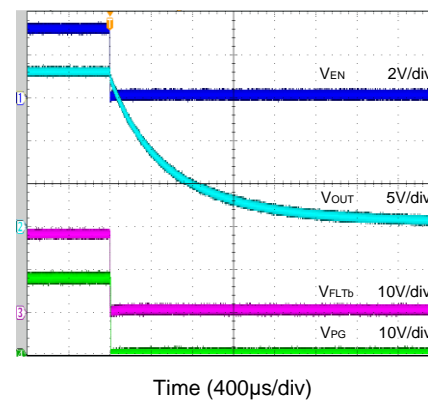

V_{IN} Startup ($V_{IN}=18V$, EN ON, $C_{dVdt}=1nF$, $C_{OUT}=100\mu F$, 6 Ω Load)

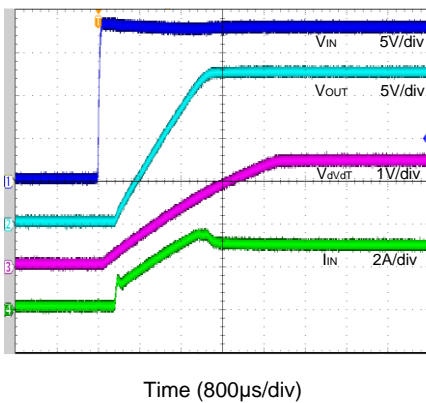

V_{IN} Shutdown ($V_{IN}=18V$, EN ON, $C_{dVdt}=1nF$, $C_{OUT}=100\mu F$, 6 Ω Load)

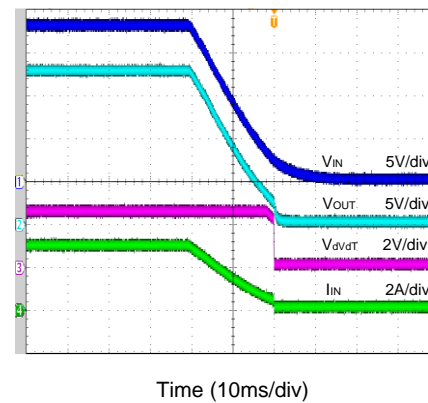

Over-voltage Shutdown
 ($V_{IN}=18V \rightarrow 20V$, $R_{FLTb}=100k\Omega$, 18 Ω Load)

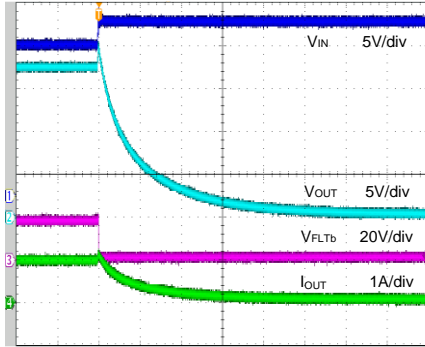

Time (40 μ s/div)

Over-voltage Recovery
 ($V_{IN}=20V \rightarrow 18V$, $R_{FLTb}=100k\Omega$, 18 Ω Load)

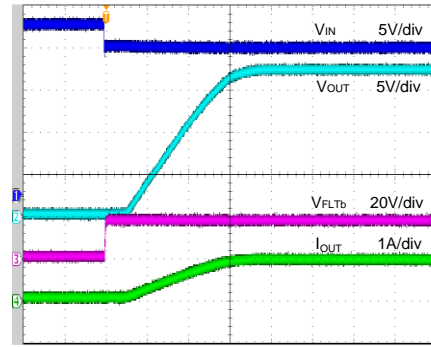

Time (100 μ s/div)

Application Information

The SY28876A is a smart eFuse with integrated back-to-back MOSFETs and enhanced built-in protection circuitry. It is ideal for all systems and applications powered from 2.7V to 18V.

For hot-plug applications, the device provides hot-swap power management with an in-rush current limit during a programmable soft-start. The device is equipped with a precision over-current limit used to minimize over-design of the input power supply. The device also integrates a short circuit protection that helps protect both the part and system from a sudden high-current event when a short circuit is detected. The over-current limit can be programmed between 0.6A and 5.3A using an external resistor.

Undervoltage Lockout and Overvoltage Set Point:

The under-voltage lockout (UVLO) and overvoltage trip point are adjusted using the external voltage divider network consisting of R_1 , R_2 , and R_3 , which connected between the IN, EN, OVP, and GND pins of the device. The values required are calculated by solving the following equations:

$$V_{OVPR} (V) = \frac{R_3}{R_1 + R_2 + R_3} \times V_{OV}$$

$$V_{ENR} (V) = \frac{R_2 + R_3}{R_1 + R_2 + R_3} \times V_{OV}$$

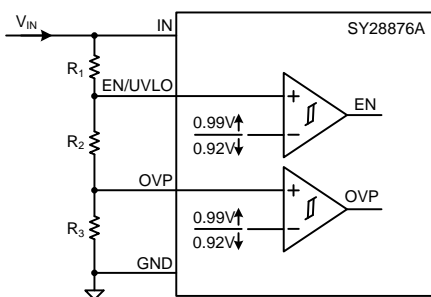

Figure 3.

UVLO and OVP thresholds set by R_1 , R_2 and R_3

It is recommended to use larger resistance values for R_1 , R_2 , and R_3 to minimize the input current drawn from the power supply.

However, this can add errors in these calculations due to leakage currents from external devices connected to the resistor string. Using a resistor string current 20x larger than the expected leakage current is recommended to obtain good thresholds accuracy.

Overload Protection:

The device continuously monitors the load current and keeps it limited to the value programmed by R_{LIM} . During overload events, the current limit is set to I_{LIM} (over-load current limit), as shown in the following equation:

$$I_{LIM} = \frac{89}{R_{LIM}}$$

Where:

- I_{LIM} is overload current limit in Amperes.
- R_{LIM} is the current limiting resistor value, in k Ω .

The internal current-limit amplifier regulates the output current to I_{LIM} in the current-limiting state. The output voltage drops, resulting in increased power dissipation for the internal FET, leading to a thermal shutdown, if the condition persists for an extended period. In this case, the device is turned off. During thermal shutdown, the SY28876A enters an auto-retry cycle 128 ms after $T_J < [T_{TSD} - 12^\circ\text{C}]$, and the fault pin /FLT is driven low to signal a fault condition.

Short Circuit Protection:

The device features a separate high-bandwidth current sense comparator with a fast-trip threshold ($I_{FASTRIP}$). $I_{FASTRIP}$ is adjusted based on the selected current limit:

$$I_{FASTRIP} = 1.4 \times I_{LIM} + 2$$

The device's current increases rapidly during a transient short circuit event. As the current-limit amplifier cannot respond quickly to this event due to its limited bandwidth, the fast-trip circuit ensures that the device can respond to and control the current within 1 μs when detecting a short circuit event ($I_{OUT} > I_{FASTRIP}$). The fast-trip circuit holds the internal MOSFET off for a few microseconds, after which the current limit amplifier regulates the output current to I_{LIM} . Then, the device behaves similar to an overload condition.

Current Monitoring:

The device provides a current mirror at the IMON pin proportional to the output current. A resistor R_{IMON} connected from the IMON pin to the GND is used to convert the sensed current to a voltage. The sense voltage at IMON pin is calculated from equation:

$$V_{IMON} = (I_{OUT} \times GAIN_{IMON} + I_{IMON_OS}) \times R_{IMON}$$

Where:

- $GAIN_{IMON}$ = Gain factor $I_{IMON}/I_{OUT} = 52 \mu\text{A/A}$
- I_{OUT} = Load current
- $I_{IMON_OS} = 0.8 \mu\text{A (typ)}$

This output can be connected to a downstream ADC for system health monitoring. The R_{IMON} needs to be configured based on the maximum input voltage range of the ADC used. R_{IMON} is set using:

$$R_{IMON} = \frac{V_{IMONmax}}{I_{LIM} \times 52 \times 10^{-6}} \text{ k}\Omega$$

If the IMON pin voltage is not digitized with an ADC, R_{IMON} can be selected to produce a 1V/1A voltage at the IMON pin by selecting a resistor value of 20 k Ω . (1% tolerance is recommended for good accuracy).

This pin should not have a bypass capacitor to avoid delay in the current monitoring information.

IN, OUT, and GND Pins:

The device has multiple input (IN) and output (OUT) pins.

All the IN pins should be connected together and to the power source. C_{IN} is a bypass capacitor that helps control transient voltages, limit emissions and local power supply noise. Where acceptable, a value in the range of 0.1 μ F to 10 μ F is recommended for C_{IN} . The voltage rating should be 20% higher than the maximum expected input voltage.

The GND terminal is the most negative voltage in the circuit and is used as a reference unless otherwise specified.

Device Operation Modes:

The SY28876A features a dedicated DevSleep interface pin (DEVSLP) to control the device and help it enter low-power mode. The DEVSLP pin is compatible with standard hardware signals asserted from the host controller. When DEVSLP pin is pulled high, the device starts operating in low-power DevSleep mode. During this mode, the quiescent current is decreased to less than 130 μ A (95 μ A typical), the output voltage remains active, the current limit is set to $I_{DEVSLP(LIM)}$, and the reverse blocking comparator and the current monitor are disabled. All other protections remain active to ensure the system's safety even in DevSleep mode.

Hot Plug-in and In-Rush Current Control:

The device has a controlled output slew rate, providing soft start functionality. This limits the inrush current caused by the output capacitor(s) charging and enables these devices to be used in hot-swap applications. The slew rate can be decreased with an external capacitor added between the dVdT pin and the ground (as shown in Figure 4). With an external capacitor present, the slew rate can be determined by the following equation:

$$I_{dVdT} = \left(\frac{C_{dVdT}}{GAIN_{dVdT}} \right) \times \left(\frac{dV_{OUT}}{dt} \right)$$

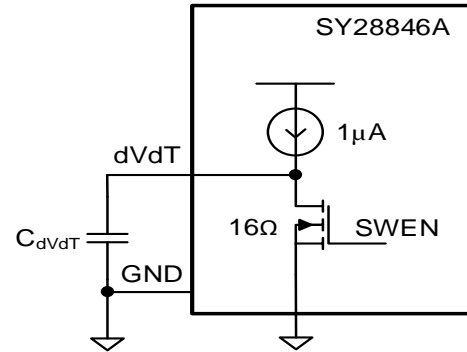

Figure 4.

Output ramp up time t_{dVdT} set by C_{dVdT}

Where:

- $I_{dVdT} = 1\mu\text{A}$ (typical)
- $\frac{dV_{OUT}}{dt}$ = Desired output slew rate
- $GAIN_{dVdT} = \text{dVdT to OUT gain} = 12$

The total ramp time (t_{dVdT}) of V_{OUT} for 0 to V_{IN} can be calculated using the equation:

$$t_{dVdT} = 8.3 \times 10^4 \times V_{IN} \times C_{dVdT}$$

The dVdT pin can be left floating if the slew rate is not decreased. When left floating, the device uses the default value of 48V/ms for the output slew rate.

FAULT Response:

The /FLT pin asserts (active low) when one of the following fault conditions are detected: under-voltage, over-voltage, reverse blocking, and thermal shutdown. The /FLT signal remains asserted until the fault conditions are addressed and the device resumes regular operation. An internal "degitch" circuit for under-voltage and over-voltage (2.2 μ s typical) filters unexpected false faults during transients on the input bus. Using this pin requires an external pull-up resistor to an external voltage rail. If /FLT reporting is not used in the application, the /FLT pin may be left open or tied to the ground. V_{IN} falling below $V_{UVF} = 2.1 \text{ V}$ resets the /FLT pin status.

Power Good Comparator:

The power-good (PGOOD) output can indicate whether the output voltage is above a user-defined threshold and can, therefore, be considered within the acceptable range by downstream DC-DC converters or system monitoring circuits. A resistor divider connected to the

PGTH pin sets an accurate power-good threshold for the output voltage. The PGOOD pin is an open-drain output that is high-impedance when the voltage at the PGTH pin is higher than 0.99 V.

The PGOOD signal has deglitch time incorporated to ensure that internal FET is fully biased before downstream converters apply heavy load. Controlling the de-glitch delay can be done by using the equation:

$$t_{\text{PGOOD(deg)}} = \text{Maximum} \{ (3.5 \times 10^6 \times C_{\text{dVdT}}), t_{\text{PGOODR}} \}$$

The pin requires an external pull-up resistor to the input or output voltage rails. If PGOOD reporting is not used, PGOOD may be left open or tied to the ground.

Thermal Shutdown:

Internal overtemperature shutdown turns off the MOSFET when $T_J > 160^\circ\text{C}$ (typical). The SY28876A starts an auto-retry cycle 128ms after T_J drops below $[T_{\text{TSD}} - 12^\circ\text{C}]$. During the thermal shutdown, the fault pin /FLT is driven low to signal a fault condition.

Application Schematic

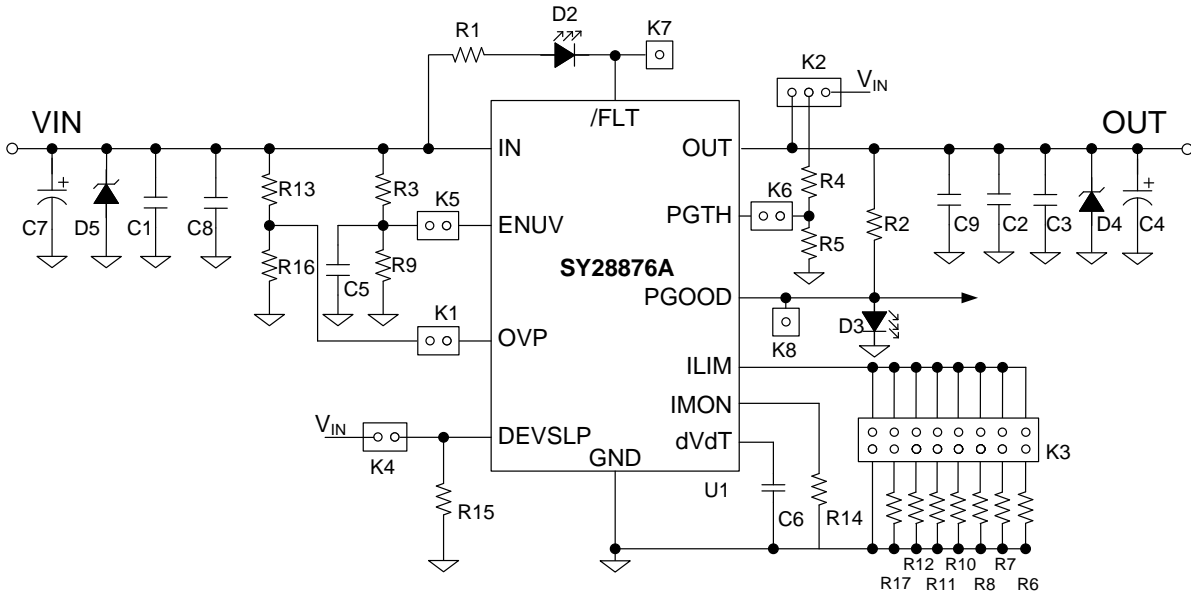

BOM List

Reference Designator	Description	Part Number	Manufacturer
C ₁ , C ₂ , C ₃ , C ₉	10μF/50V, 1206	GRM319R61E106KA12D+A01	Murata
C ₄ , C ₇	electrolytic capacitor (optional)		
C ₅	1nF/50V, 0603	GRM188R61H102KA01D+C01A	Murata
C ₆	10nF/50V, 0603	GRM188R61H102KA01D+C01A	Murata
C ₈	100nF/50V, 0402 (optional)		
D ₂ , D ₃	LED		
D ₄	40V, 5A, Schottky	SS54	
D ₅	TVS (optional)		
R ₁ , R ₂ , R ₄ , R ₁₅	100kΩ, 0603	RC0603FR-07100KL	YAGEO
R ₃	120kΩ, 0603	RC0603FR-07120KL	YAGEO
R ₅ , R ₁₆	10kΩ, 0603	RC0603FR-0710KL	YAGEO
R ₆ , R ₁₃	150kΩ, 0603	RC0603FR-07150KL	YAGEO
R ₇	88.7kΩ, 0603	RC0603FR-0788K7L	YAGEO
R ₈	42.2kΩ, 0603	RC0603FR-0742K2L	YAGEO
R ₉	15kΩ, 0603	RC0603FR-0715KL	YAGEO
R ₁₀	24.9kΩ, 0603	RC0603FR-0724K9L	YAGEO
R ₁₁ , R ₁₄	20kΩ, 0603	RC0603FR-0720KL	YAGEO
R ₁₂	16.9kΩ, 0603	RC0603FR-0716K9L	YAGEO
R ₁₇	39kΩ, 0603	RC0603FR-0739KL	YAGEO

PCB Layout Guide:

1. A 0.1μF or greater ceramic decoupling capacitor is recommended for all applications between the IN terminal and the GND. For hot-plug applications, where input power path inductance is negligible, this capacitor can be eliminated or its value reduced.
2. The optimum placement of the decoupling capacitor is closest to the IN and GND terminals of the device. Care must be taken to minimize the loop area formed by the bypass-capacitor connection, the IN terminal, and the GND terminal of the device.
3. Place all external components: R_{ILIM}, C_{dVdT}, R_{IMON}, and resistors for UVLO and OVP, close to their connection pins. Connect the components to the SGND with the shortest trace length to reduce parasitic effects.

4. The trace routing for the R_{ILIM} and R_{IMON} components to the device should be as short as possible to reduce parasitic effects on the current limit and current monitoring accuracy. These traces should not be coupled to any switching signals on the board.
5. Connect the SGND plane to the PGND (main power ground) at a single point, near the input capacitor's negative terminal.
6. Protection devices such as TVS, snubbers, capacitors, or diodes should be placed physically close to the device they intend to protect and routed with short traces to reduce the parasitic inductance. For example, a Schottky diode across the output can be used to absorb negative spikes.

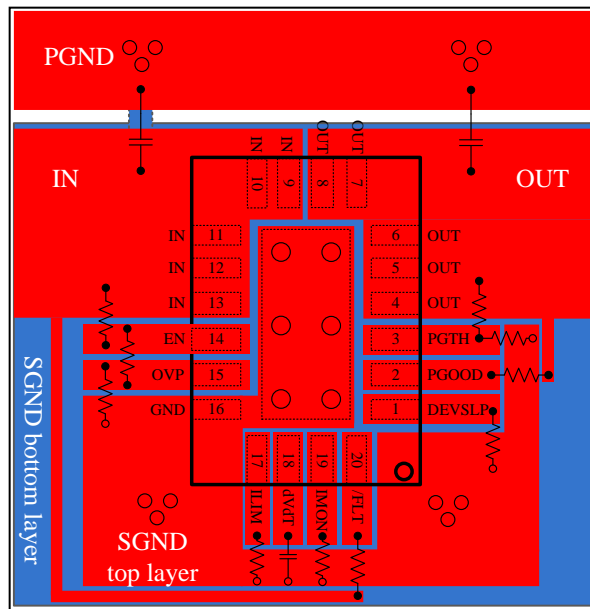
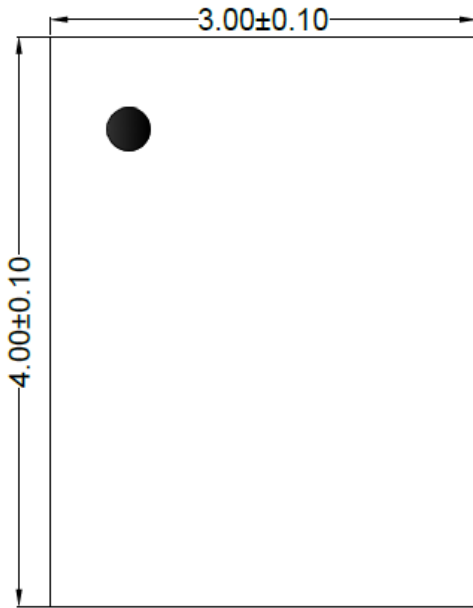
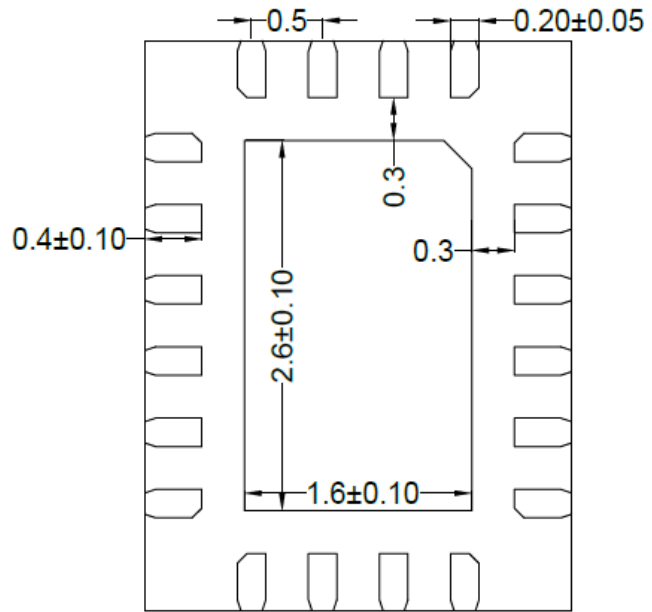

Figure 5. PCB Layout Suggestion

QFN3x4-20 Package Outline Drawing



Top View



Bottom View

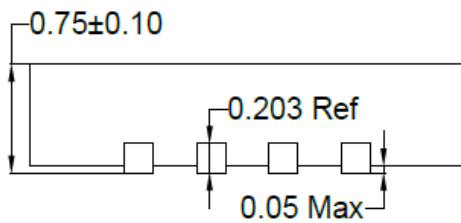

Side View

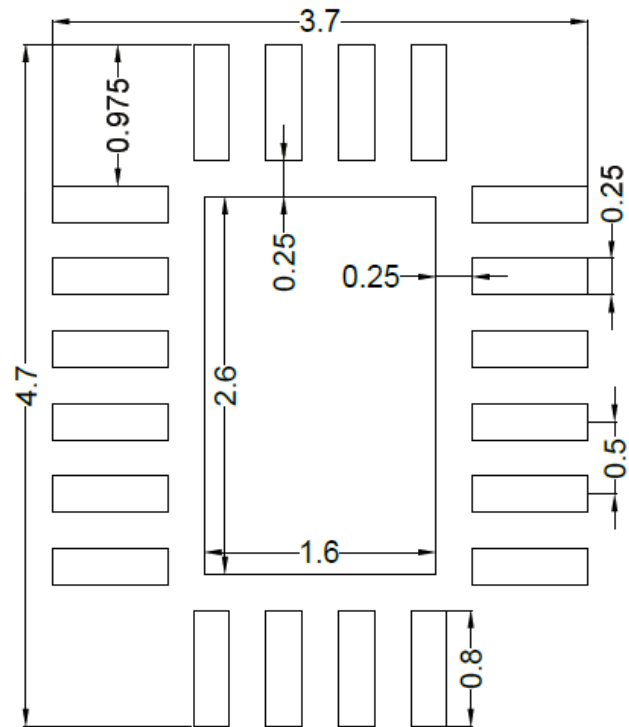

**Recommended PCB Layout
(Reference Only)**

Note: All dimensions are in millimeters and exclude mold flash and metal burr.

Taping & Reel Specification

QFN3x4 Taping Orientation

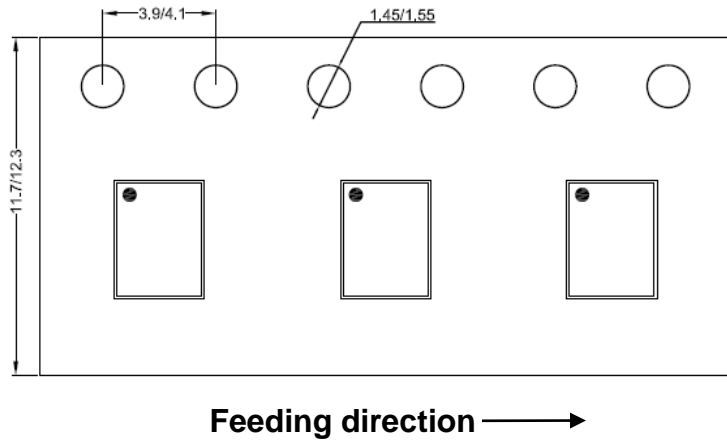

Carrier Tape & Reel Specification for Packages

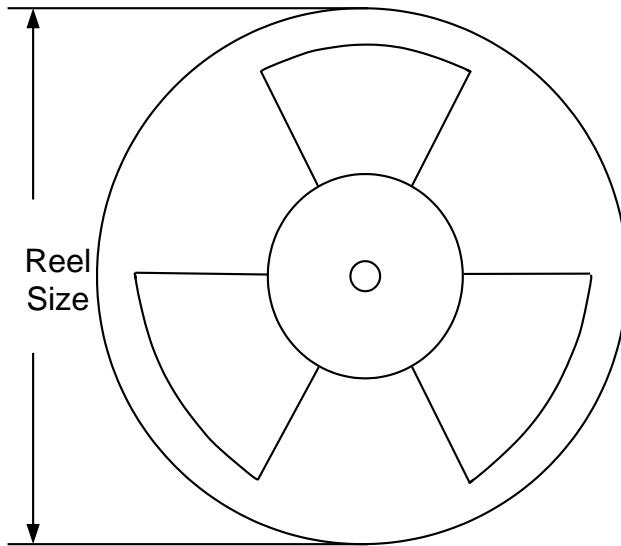

Package types	Tape width (mm)	Pocket pitch (mm)	Reel size (Inch)	Trailer length (mm)	Leader length (mm)	Qty per reel
QFN3x4	12	8	13"	400	400	5000

Revision History

The revision history provided is for informational purpose only and is believed to be accurate, however, not warranted. Please make sure that you have the latest revision.

Date	Revision	Change
Dec.08, 2023	Revision 1.0	Language improvements for clarity.
Nov.05, 2021	Revision 0.9B	1. Add UL Certificate Number in Features (page 1)
Dec.16, 2020	Revision 0.9A	<ol style="list-style-type: none"> 1. Change reverse blocking threshold from -10mV to -25mV in figure 2 (page 3) 2. Update /FLT logic circuit in figure 2 (page 3) 3. Changed OUT absolute maximum ratings from (-0.3V to 20V) to (-1V to 20V) in page 3 4. Change “a low effective single layer thermal conductivity test board” to “a high effective four-layer thermal conductivity test board” in Note 2 (page 6) 5. Change “an internal ramp rate of 12V/ms for output (VOUT) ramp” to “an internal ramp rate of 48V/ms for output (VOUT) ramp”. (page 12)
Jun.22, 2020	Revision 0.9	Initial Release

IMPORTANT NOTICE

1. **Right to make changes.** Silergy and its subsidiaries (hereafter Silergy) reserve the right to change any information published in this document, including but not limited to circuitry, specification and/or product design, manufacturing or descriptions, at any time and without notice. This document supersedes and replaces all information supplied prior to the publication hereof. Buyers should obtain the latest relevant information before placing orders and should verify that such information is current and complete. All semiconductor products are sold subject to Silergy's standard terms and conditions of sale.

2. **Applications.** Application examples that are described herein for any of these products are for illustrative purposes only. Silergy makes no representation or warranty that such applications will be suitable for the specified use without further testing or modification. Buyers are responsible for the design and operation of their applications and products using Silergy products. Silergy or its subsidiaries assume no liability for any application assistance or designs of customer products. It is customer's sole responsibility to determine whether the Silergy product is suitable and fit for the customer's applications and products planned. To minimize the risks associated with customer's products and applications, customer should provide adequate design and operating safeguards. Customer represents and agrees that it has all the necessary expertise to create and implement safeguards which anticipate dangerous consequences of failures, monitor failures and their consequences, lessen the likelihood of failures that might cause harm and take appropriate remedial actions. Silergy assumes no liability related to any default, damage, costs or problem in the customer's applications or products, or the application or use by customer's third-party buyers. Customer will fully indemnify Silergy, its subsidiaries, and their representatives against any damages arising out of the use of any Silergy components in safety-critical applications. It is also buyers' sole responsibility to warrant and guarantee that any intellectual property rights of a third party are not infringed upon when integrating Silergy products into any application. Silergy assumes no responsibility for any said applications or for any use of any circuitry other than circuitry entirely embodied in a Silergy product.

3. **Limited warranty and liability.** Information furnished by Silergy in this document is believed to be accurate and reliable. However, Silergy makes no representation or warranty, expressed or implied, as to the accuracy or completeness of such information and shall have no liability for the consequences of use of such information. In no event shall Silergy be liable for any indirect, incidental, punitive, special or consequential damages, including but not limited to lost profits, lost savings, business interruption, costs related to the removal or replacement of any products or rework charges, whether or not such damages are based on tort or negligence, warranty, breach of contract or any other legal theory. Notwithstanding any damages that customer might incur for any reason whatsoever, Silergy' aggregate and cumulative liability towards customer for the products described herein shall be limited in accordance with the Standard Terms and Conditions of Sale of Silergy.

4. **Suitability for use.** Customer acknowledges and agrees that it is solely responsible for compliance with all legal, regulatory and safety-related requirements concerning its products, and any use of Silergy components in its applications, notwithstanding any applications-related information or support that may be provided by Silergy. Silergy products are not designed, authorized or warranted to be suitable for use in life support, life-critical or safety-critical systems or equipment, nor in applications where failure or malfunction of a Silergy product can reasonably be expected to result in personal injury, death or severe property or environmental damage. Silergy assumes no liability for inclusion and/or use of Silergy products in such equipment or applications and therefore such inclusion and/or use is at the customer's own risk.

5. **Terms and conditions of commercial sale.** Silergy products are sold subject to the standard terms and conditions of commercial sale, as published at <http://www.silergy.com/stdterms>, unless otherwise agreed in a valid written individual agreement specifically agreed to in writing by an authorized officer of Silergy. In case an individual agreement is concluded only the terms and conditions of the respective agreement shall apply. Silergy hereby expressly objects to and denies the application of any customer's general terms and conditions with regard to the purchase of Silergy products by the customer.

6. **No offer to sell or license.** Nothing in this document may be interpreted or construed as an offer to sell products that is open for acceptance or the grant, conveyance or implication of any license under any copyrights, patents or other industrial or intellectual property rights. Silergy makes no representation or warranty that any license, either express or implied, is granted under any patent right, copyright, mask work right, or other intellectual property right. Information published by Silergy regarding third-party products or services does not constitute a license to use such products or services or a warranty or endorsement thereof. Use of such information may require a license from a third party under the patents or other intellectual property of the third party, or a license from Silergy under the patents or other intellectual property of Silergy.

For more information, please visit: www.silergy.com

© 2021 Silergy Corp.

All Rights Reserved.