

General Description

The SY28481B load switch is an ultra-low on-resistance, compact device with inrush current limit via programmable soft-start. The device provides power good signaling for system status monitoring and downstream load control. With soft-start capabilities to reduce inrush current and low power consumption in a small footprint, the SY28481B is ideal for power management and hot-swap applications.

The SY28481B is available in a compact DFN3×3-12 package.

Features

- Integrated N-Channel MOSFET with Ultra Low R_{ON}
- Input Voltage Range 3 V to 24 V
- 3V to 5.5V Input Voltage Range for VCC
- Programmable Soft Start time
- Fault Detection with Power Good Output
- Thermal Shutdown Protection
- Short Circuit and Adjustable Over-Current Protection and latch off
- Output capacitor discharge during EN OFF
- Extremely Low Standby Current

Applications

- USB Type C Power Delivery
- Portable Electronics and Systems
- Notebook and Tablet Computers
- Telecom, Networking, Medical, and Industrial Equipment
- Set-Top Boxes, Servers, and Gateways
- Hot-Swap Devices and Peripheral Ports

Typical Application

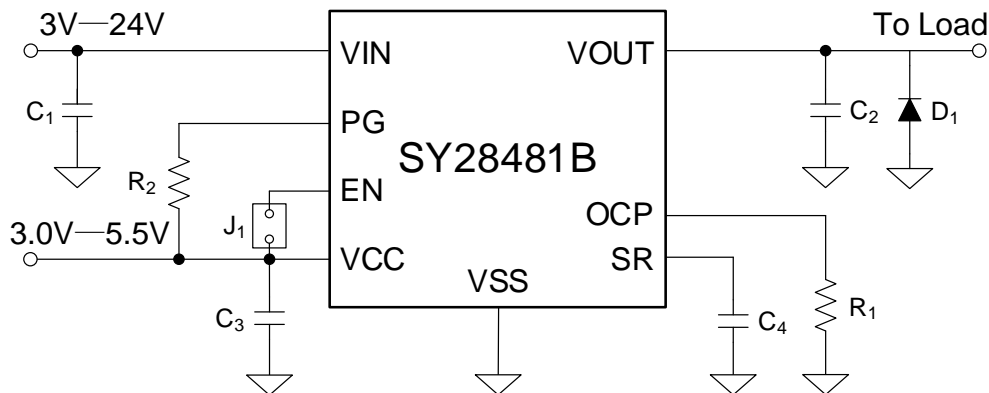

Figure 1. Schematic Diagram



SILERGY

SY28481B

Ordering Information

Pinout (top view)

Ordering Part Number	Package Type	Top Mark
SY28481BDCD	DFN3x3-12 RoHS Compliant and Halogen Free	EHQxyz

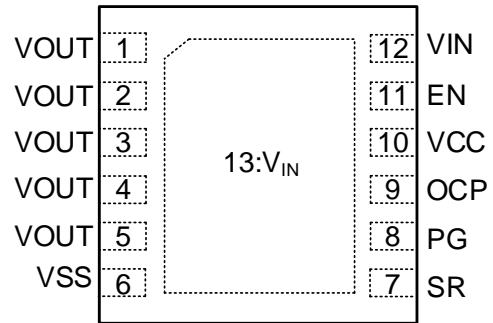

Device code: EHQ

x=year code, y=week code, z= lot number code

Pin Description

Pin Name	Pin number	Pin Description
VOUT	1, 2, 3, 4, 5	Source of MOSFET connected to load. Includes an internal bleed resistor to GND. All pins must be connected to provide correct R _{ON} , OCP, and current capability.
VSS	6	Driver ground
SR	7	Slew Rate control pin. Slew rate adjustment made with an external capacitor to GND. Leave it floating if not used.
PG	8	Active-high, open-drain output that indicates when the gate of the MOSFET is fully charged, external pull up resistor ≥ 1kΩ to an external voltage source required; tie to GND if not used.
OCP	9	Over-current protection trip point adjustment made with a resistor to ground; short to ground if over-current protection is not needed.
VCC	10	Driver supply voltage (3.0 V – 5.5 V)
EN	11	Active-high digital input used to turn on the MOSFET driver, pin has an internal pull-down resistor to GND.
VIN	12, 13	Input voltage (3 V – 24 V) – Pin 13 should be used for high current (>0.5 A)

Block Diagram

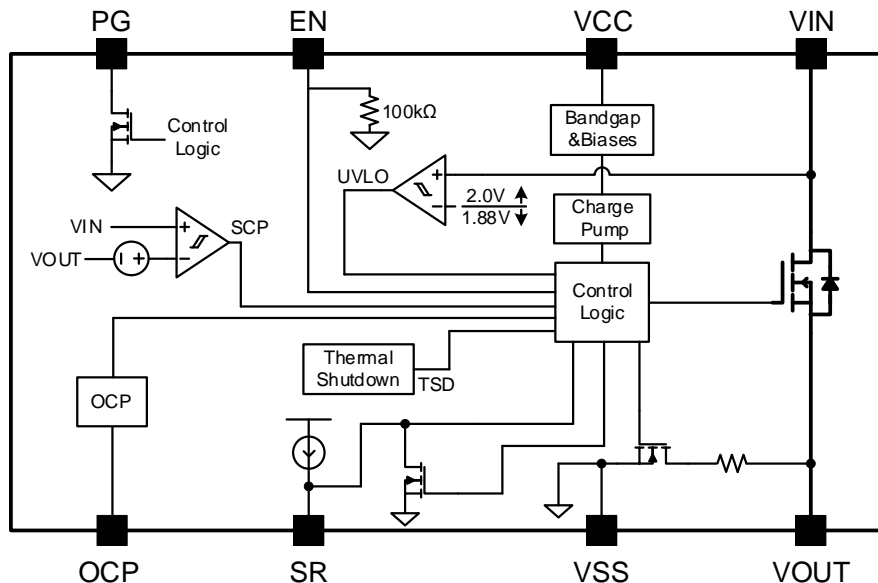

Figure 2 Block Diagram

Absolute Maximum Ratings

Parameter (Note 1)	Min	Max	Unit
VCC, EN, PG, OCP	-0.3	6	V
VIN, VOUT	-0.3	30	
I _{MAX} (Note 2)		10	A
Lead Temperature (Soldering, 10s)		260	°C
Junction Temperature, Operating	-40	150	
Storage Temperature	-65	150	

Thermal Information

Parameter (Note 3)	Typ	Unit
θ_{JA} Junction-to-Ambient Thermal Resistance	35	°C/W
θ_{JC} Junction-to-Case Thermal Resistance	1.7	
P _D Power Dissipation T _A = 25°C	2.86	W

Recommended Operating Conditions

Parameter (Note 4)	Min	Max	Unit
VCC	3	5.5	V
VIN, VOUT	3	24	
EN, PG	0	5.5	
OCP External Resistor to VSS	short	open	
Junction Temperature, Operating	-40	125	°C
Ambient Temperature	-40	85	

**Electrical Characteristics**

($R_{PG} = 100k\Omega$; $R_L = 10\Omega$, $C_L = 0.1\mu F$, $T_J = -40^\circ C$ to $125^\circ C$, typical values are $T_J = 25^\circ C$, unless otherwise specified. The values are guaranteed by test, design or statistical correlation.)

Parameter	Symbol	Test Conditions	Min	Typ	Max	Unit
MOSFET						
On-Resistance	R_{ON}	$V_{CC} = 3.3 V$; $V_{IN} = 24 V$		5.2	9	m Ω
Leakage Current	I_{LEAK}	$V_{EN} = 0 V$; $V_{IN} = 24 V$		0.1	10	μA
CONTROLLER						
V_{IN} Control Current – V_{IN} to V_{SS}	I_{INCTL}	$V_{EN} = 0 V$; $V_{IN} = 24 V$; $V_{CC} = 3.3 V$			30	μA
V_{IN} Control Current – V_{IN} to V_{SS}	I_{INCTL_EN}	$V_{EN} = V_{CC} = 3.3 V$; $V_{IN} = 24 V$			260	μA
Supply Standby Current	I_{STBY}	$V_{EN} = 0 V$; $V_{IN} = 24 V$; $V_{CC} = 3.3 V$		2.0	8.0	μA
Supply Dynamic Current	I_{DYN}	$V_{EN} = V_{CC} = 3.3 V$; $V_{IN} = 24 V$			0.11	mA
Bleed Resistance	R_{BLEED}		40	95	150	k Ω
EN Input High Voltage	V_{IH}		2.0			V
EN Input Low Voltage	V_{IL}				0.8	V
EN Input Leakage Current	I_{IL}	$V_{EN} = 0 V$	-1.0		1.0	μA
EN Pull Down Resistance	R_{PD}		75	100	130	k Ω
PG Output Low Voltage	V_{OL}	$V_{CC} = 3 V$; $I_{SINK} = 5 mA$			0.25	V
PG Output Leakage Current	I_{OH}	$V_{PG} = 3.3 V$		3.3	100	nA
Slew Rate Control Constant	K_{SR}	SR pin floating (default)	60	95	130	μA
FAULT PROTECTIONS						
Thermal Shutdown Threshold (Note 5)	T_{TSD}			145		$^\circ C$
Thermal Shutdown Hysteresis (Note 5)	T_{HYS}			20		$^\circ C$
V_{IN} Undervoltage Lockout Threshold	V_{UVLO}	V_{IN} rising		2.0	2.1	V
V_{IN} Undervoltage Lockout Hysteresis	V_{HYS}	$V_{CC} = 3 V$		220	300	mV
Over-Current Protection Trip	I_{TRIP}	$R_{OCP} = \text{open}$	0.85	1.2	1.45	A
		$R_{OCP} = 32 k\Omega$		7.5		
		$R_{OCP} = \text{short to GND}$		12		
Over-Current Protection Blanking Time	t_{OCP}			2.25		ms
Short-Circuit Protection Trip Current (Note 5)	I_{SC}	Soft Short & Hard Short		20		A

Switching Characteristics

($R_{PG} = 100k\Omega$; $R_L = 10\Omega$, $C_L = 0.1\mu F$, $T_J = -40^\circ C$ to $125^\circ C$, typical values are $T_J = 25^\circ C$, unless otherwise specified. The values are guaranteed by test, design or statistical correlation)

Parameter	Symbol	Test Conditions	Min	Typ	Max	Unit
Output Slew Rate	SR	$V_{CC} = 4.5 V$; $V_{IN} = 3 V$	7	15	25	kV/s
		$V_{CC} = 5.0 V$; $V_{IN} = 3 V$	7	15	25	
		$V_{CC} = 3.3 V$; $V_{IN} = 24 V$	10	20	26	
		$V_{CC} = 5.0 V$; $V_{IN} = 24 V$	10	20	26	
Output Turn-on Delay	t_{ON}	$V_{CC} = 4.5 V$; $V_{IN} = 3 V$	100	330	700	μs
		$V_{CC} = 5.0 V$; $V_{IN} = 3 V$	100	330	700	
		$V_{CC} = 3.3 V$; $V_{IN} = 24 V$	100	410	700	
		$V_{CC} = 5.0 V$; $V_{IN} = 24 V$	100	410	700	
Output Turn-off Delay	t_{OFF}	$V_{CC} = 4.5 V$; $V_{IN} = 3 V$		48		μs
		$V_{CC} = 5.0 V$; $V_{IN} = 3 V$		48		
		$V_{CC} = 3.3 V$; $V_{IN} = 24 V$		48		
		$V_{CC} = 5.0 V$; $V_{IN} = 24 V$		48		
Power Good Turn-on Time	$t_{PG,ON}$	$V_{CC} = 4.5 V$; $V_{IN} = 3 V$	0.25	0.68	2.5	ms
		$V_{CC} = 5.0 V$; $V_{IN} = 3 V$	0.25	0.72	2.5	
		$V_{CC} = 3.3 V$; $V_{IN} = 24 V$	0.25	1.4	2.5	
		$V_{CC} = 5.0 V$; $V_{IN} = 24 V$	0.25	1.4	2.5	
Power Good Turn-off Time	$t_{PG,OFF}$	$V_{CC} = 4.5 V$; $V_{IN} = 3 V$		4.5		μs
		$V_{CC} = 5.0 V$; $V_{IN} = 3 V$		4.5		
		$V_{CC} = 3.3 V$; $V_{IN} = 24 V$		4.5		
		$V_{CC} = 5.0 V$; $V_{IN} = 24 V$		4.5		

Note 1: Stresses beyond the “Absolute Maximum Ratings” may cause permanent damage to the device. These are stress ratings only. Functional operation of the device at these or any other conditions beyond those indicated in the operational sections of the specification is not implied. Exposure to absolute maximum rating conditions for extended periods may affect device reliability.

Note 2: Ensure that the expected operating MOSFET current will not cause the Short-Circuit Protection to turn the MOSFET off undesirably.

Note 3: θ_{JA} is measured in the natural convection at $T_A = 25^\circ C$ on a Silergy EVB test board.

Note 4: The device is not guaranteed to function outside its operating conditions.

Note 5: Guaranteed by design, not production test.

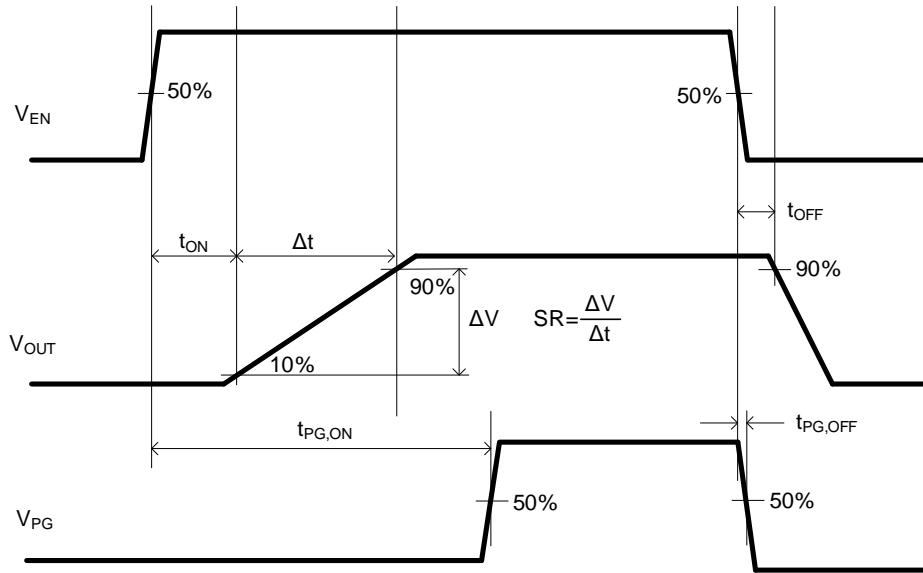

Figure3. Switching Time Waveform

SOA

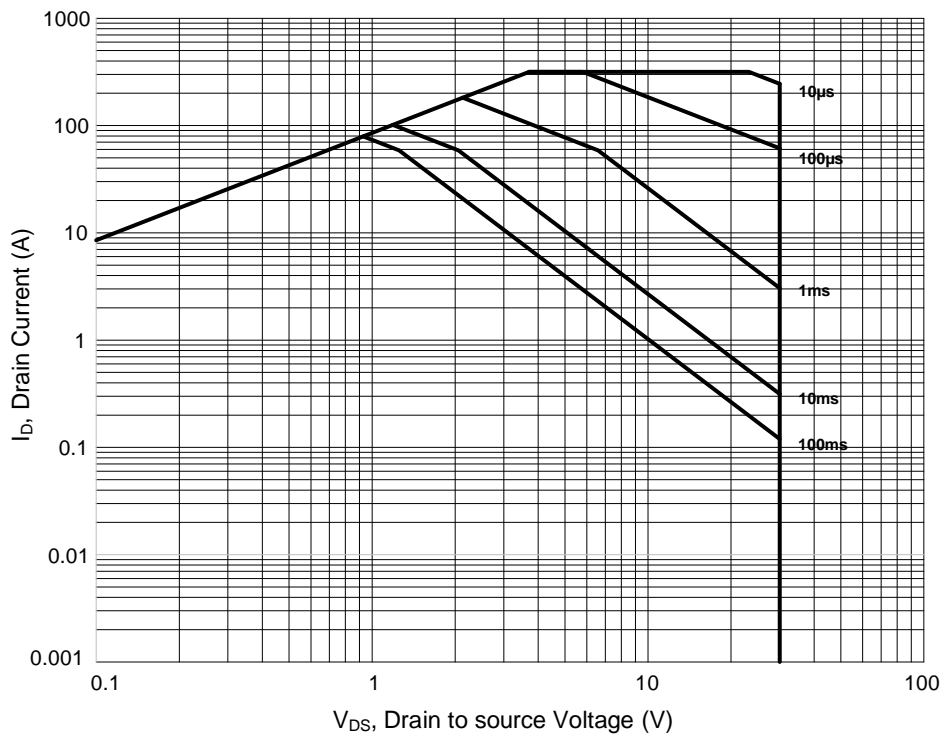
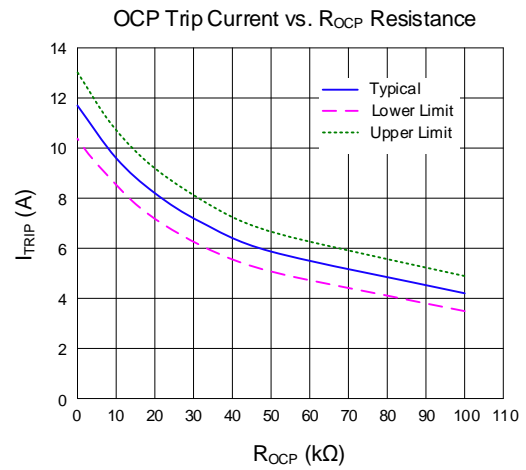
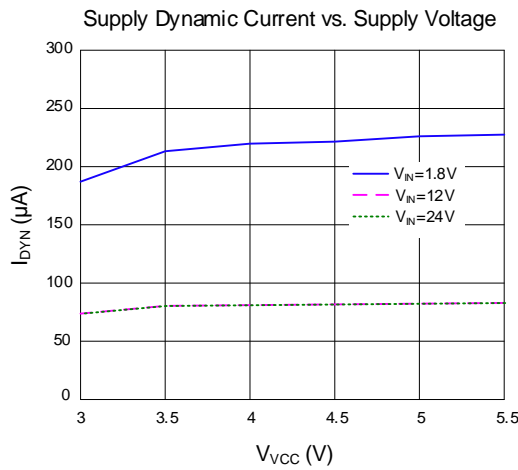
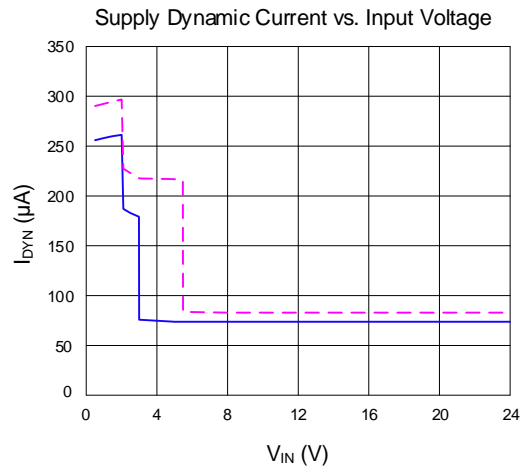
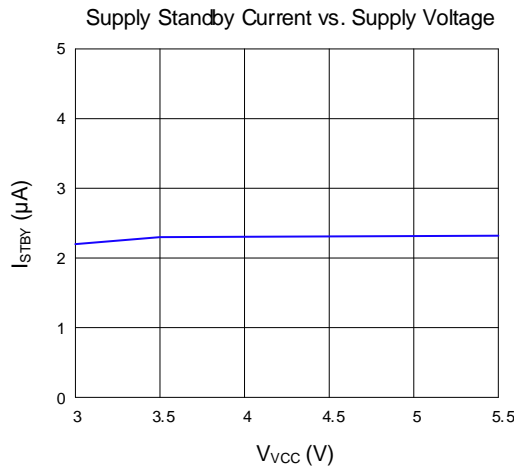
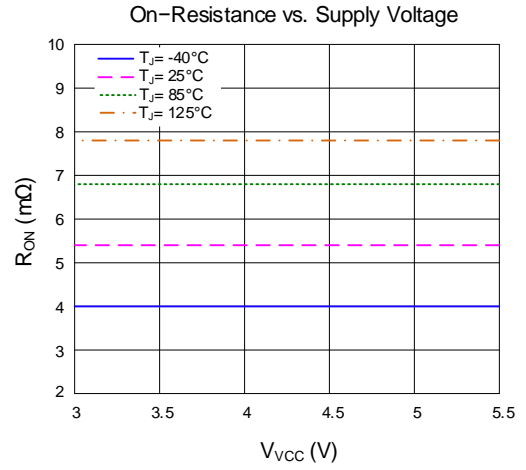
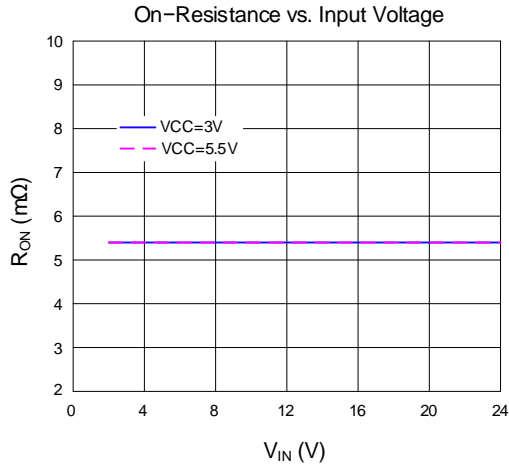
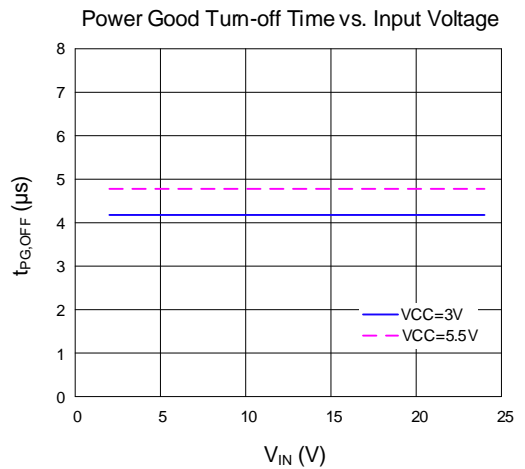
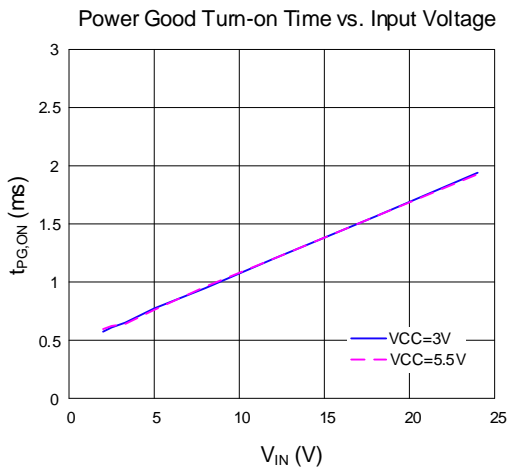
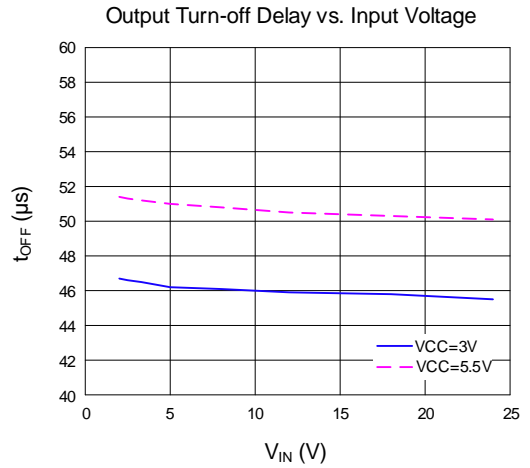
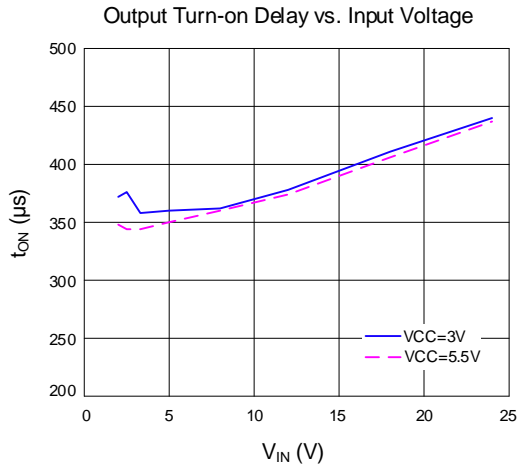
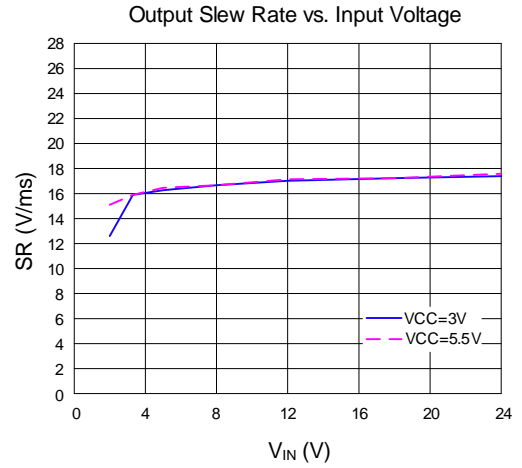
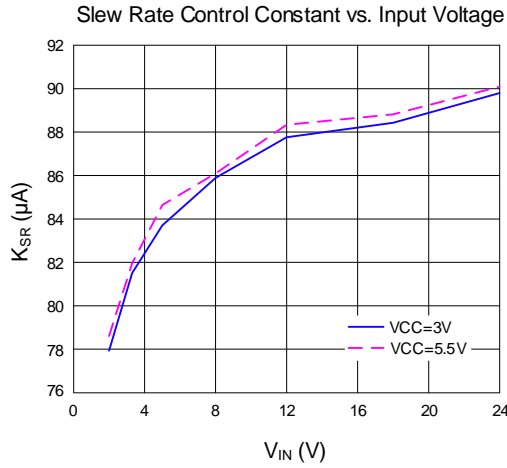

Figure 4. Safe Operating Area

Typical Performance Characteristics





Turn ON with Enable
 ($V_N=12V, V_{VCC}=3V, C_{SR}=100nF, C_{OUT}=100nF, 5mF$ Load)

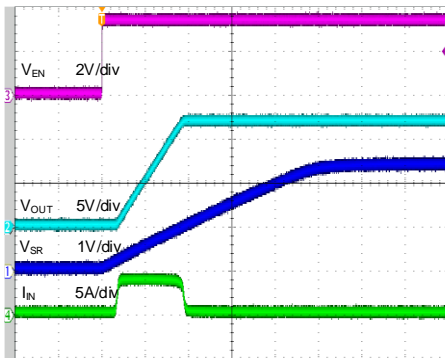

Time (10ms/div)

Turn OFF with Enable
 ($V_N=12V, V_{VCC}=3V, C_{SR}=100nF, C_{OUT}=100nF, 5mF$ Load)

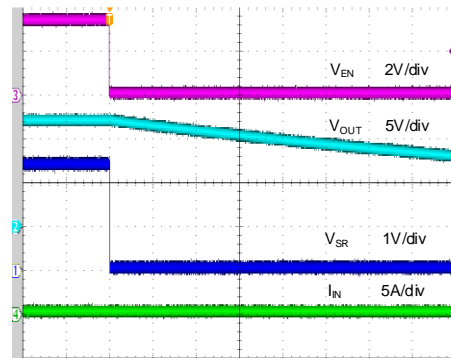

Time (1s/div)

Hot Plug (V_{IN})
 ($V_N=24V, V_{VCC}=V_{EN}=6V, C_{SR}=C_N=Open, C_{OUT}=100\mu F$)

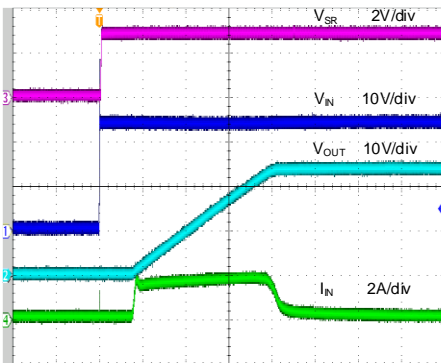

Time (400 μ s/div)

Hot Plug (V_{VCC})
 ($V_{VCC}=V_{EN}=6V, V_N=24V, C_{SR}=C_{VCC}=Open, C_{OUT}=100\mu F$)

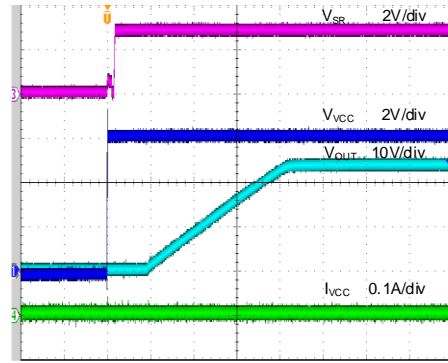

Time (400 μ s/div)

Over Current Protection
 ($V_N=12V, V_{VCC}=3V, R_{OCP}=100k\Omega, C_{SR}=100nF, C_{OUT}=100nF, 5mF$ Load, Null Load $\rightarrow 2\Omega$)

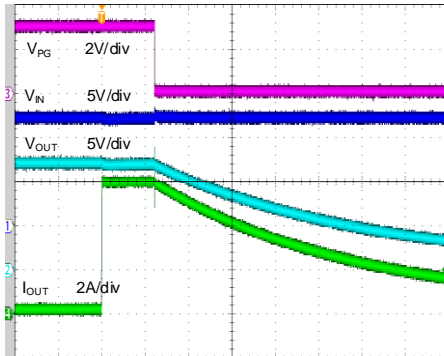

Time (2ms/div)

Hard Short
 ($V_N=12V, V_{VCC}=3V, R_{OCP}=100k\Omega, C_{SR}=100nF, C_{OUT}=100nF, 5mF$ Load, Short OUT)

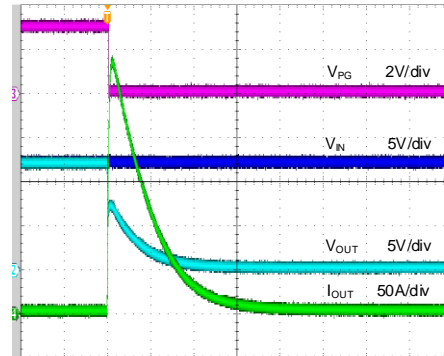

Time (200 μ s/div)

Applications Information

The SY28481B load switch is an ultra-low on-resistance, compact device with inrush current limit via programmable soft-start. The device provides power good signaling for system status monitoring and downstream load control. With soft-start capabilities to reduce inrush current and low power consumption in a small footprint, the SY28481B is ideal for power management and hot-swap applications.

Under voltage Lockout

The SY28481B integrates UVLO protection. If VIN rise above UVLO threshold and EN is set to high, the power FET will controlled to turn on with soft start. If VIN fall below UVLO threshold-hysteresis, the device is shutdown.

Enable Control

EN is used to control the SY28481BDCD ON and OFF. When VCC and VIN is in operation voltage range, setting EN to a logic high level, the power FET is turned on with soft start and setting EN to a logic low level, the Power FET is turn off immediately. Set EN to low, then back to high, can reset the SY28481BDCD that has latched off due to SCP or OCP protection. The SY28481BDCD internal integrated a 100kΩ resistor to keep the device off when EN pin is not driven.

Power Sequencing

The SY28481BDCD must consider the power on timing specification for $V_{CC} \geq 3V$ before EN is enabled ($V_{EN} \leq 1.1V$ within the full temperature range) in design. To achieve the specified performance, there are two recommended power sequences:

1. $V_{CC} \rightarrow V_{IN} \rightarrow V_{EN}$
2. $V_{IN} \rightarrow V_{CC} \rightarrow V_{EN}$

Power Good

The SY28481BDCD integrates a power good indicator, PG pin. The PG pin is an active high, open drain output. This pin shall connect an external pull high resistor, to an external voltage source. 1kΩ or larger is recommended. When the MOSFET is fully enhanced. The PG pin is high impedance, the voltage on PG pin is pulled high by external resistor.

The PG pin can be used to power up sequence design. Avoid draw large current before the switch is fully enhanced which may lead to system power up fail.

Slew Rate Control

The SY28481B integrates programmable output slew rate control to reduce the inrush current during start up with large output cap. Connect a C_{SR} from SR pin to GND to program the slew rate. The slew rate can be calculated as following equation:

$$\text{Slew Rate} = \frac{K_{SR}}{C_{SR}} (V/s) \quad (1)$$

Where K_{SR} is the specified slew rate control constant, found in EC table.

To make the power FET work within SOA limits in output short circuit condition, the capacitance value of C_{SR} should not exceed 22nF.

Short-Circuit Protection

The SY28481B devices are equipped with a short-circuit protection which against output hard short to GND event.

Once VOUT is shorted to GND, large current draw VOUT low. The SY28481BDCD monitor the voltage difference between VIN and VOUT, once the voltage exceeds short circuit threshold, the power FET is shut down immediately to cut off load and prevent current increasing. The device will keep in off status until EN off/on toggle or VCC UVLO event.

The short circuit protection is active after PG is settle high.

Over-Current Protection

The device is equipped with an over-current protection (OCP) that helps protect the part and the system from a high current event which exceeds the expected operational current (e.g., a soft short).

Once the load current exceeds programmed over current threshold, an internal timer will count a 2.25ms, t_{OCP} blanking time. If over current lasts longer than t_{OCP} , Power FET is shut down and kept off status as SCP event. If load drop back to normal range t_{OCP} , the timer is reset and power FET maintain on state.

The over-current threshold is programmed by connect a resistor from OCP pin to GND, and can be calculated by following equation:

$$I_{TRIP} = \frac{420}{R_{OCP} + 40} + 1.2$$

- I_{TRIP} is OCP trip current in Ampere
- R_{OCP} is the programmable resistor in kΩ

Thermal Shutdown

The thermal shutdown of the SY28481BDCD devices protects the part from internally or externally generated excessive temperatures. When the junction temperature is higher than TSD threshold, T_{TSD} , the SY28481BDCD will shut down the power FET. After junction temperature drop below the $T_{TSD-hys}$ and EN is still keeps high, SY28481BDCD will restart with slew rate control

PCB Layout Guide

1. For all applications, a 10 μ F or greater ceramic decoupling capacitor is recommended between IN terminal and GND. For hot-plug applications, where input power path inductance is negligible, this capacitor can be eliminated/minimized.
2. The optimum placement of decoupling capacitor is closest to the IN and GND terminals of the

device. Care must be taken to minimize the loop area formed by the bypass-capacitor connection, the IN terminal, and the GND terminal of the IC.

3. Locate support components C_{VCC} , C_{SR} and R_{OCP} close to their connection pin. Connect the other end of the component to the GND with shortest trace length.
4. Protection devices such as TVS, snubbers, capacitors, or diodes should be placed physically close to the device they are intended to protect, and routed with short traces to reduce inductance. For example, a protection Schottky diode is recommended to address negative transients due to switching of inductive loads, and it should be physically close to the OUT pins.

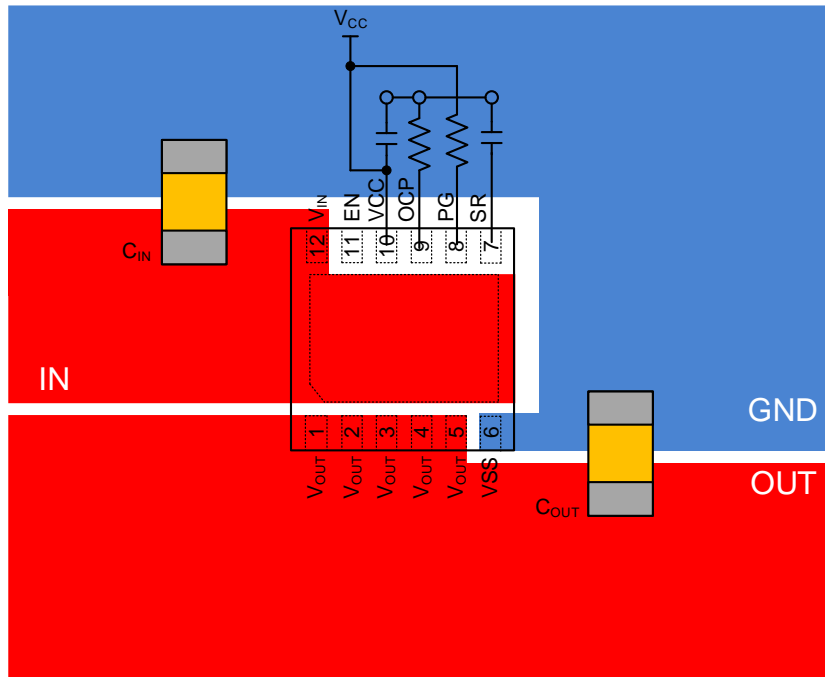

Figure5. PCB Layout Suggestion



SILERGY

Schematic

SY28481B

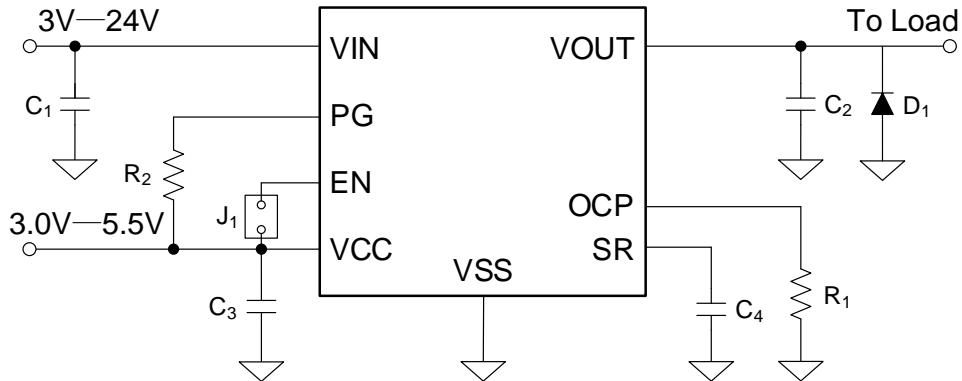

BOM List

Reference Designator	Description	Part Number	Manufacturer
C ₁	10μF/50V, ±10%, X5R, 1206	C3216X5R1H106KT00N	TDK
C ₂	10μF/50V, ±10%, X5R, 1206	C3216X5R1H106KT00N	TDK
C ₃	1μF/50V, ±10%, X5R, 0603	GRM188R61H105KAALD	Murata
C ₄	10nF/50V, ±10%, X7R, 0603	GRM188R72A103KA01D	Murata
R ₁	0Ω, 1%, 0.1W, 0603	RC0603FR-070RL	YAGEO
R ₂	100kΩ, 1%, 0.1W, 0603	RC0603FR-07100KL	YAGEO
D ₁	Schottky	SS54	Any
J ₁	Jumper, 2x1, Gold		Any

DFN3x3-12 Package outline

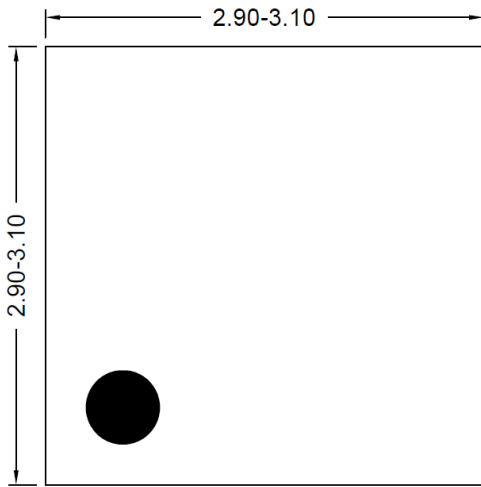

Top View

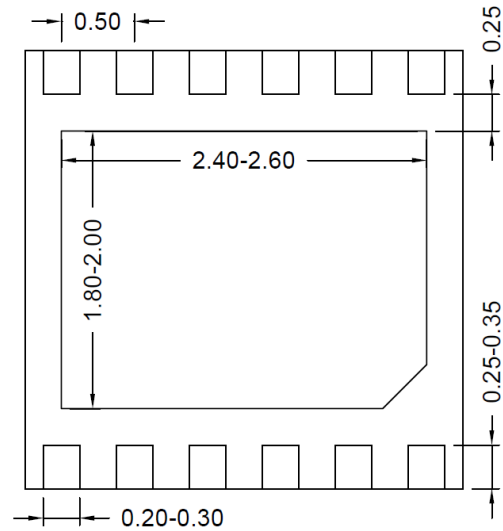

Bottom view

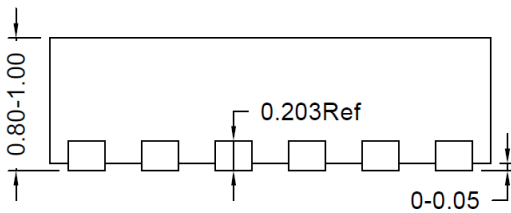

Front View

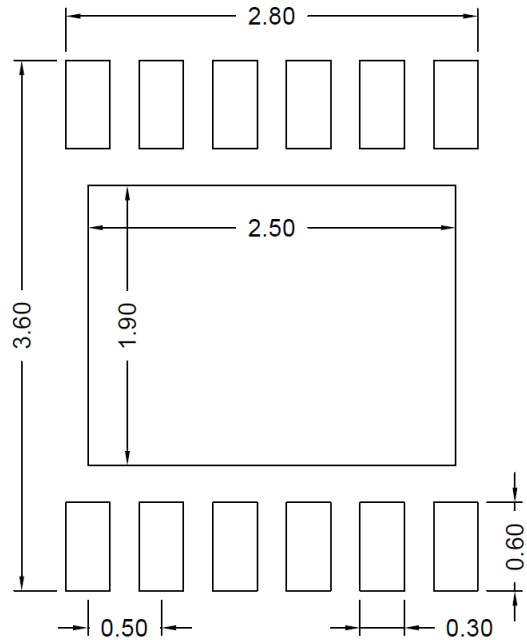

**Recommended PCB layout
(only for reference)**

Notes: All dimension in millimeter and exclude mold flash & metal burr.

Tape and Reel Information

1. Tape dimensions and Pin1 orientation

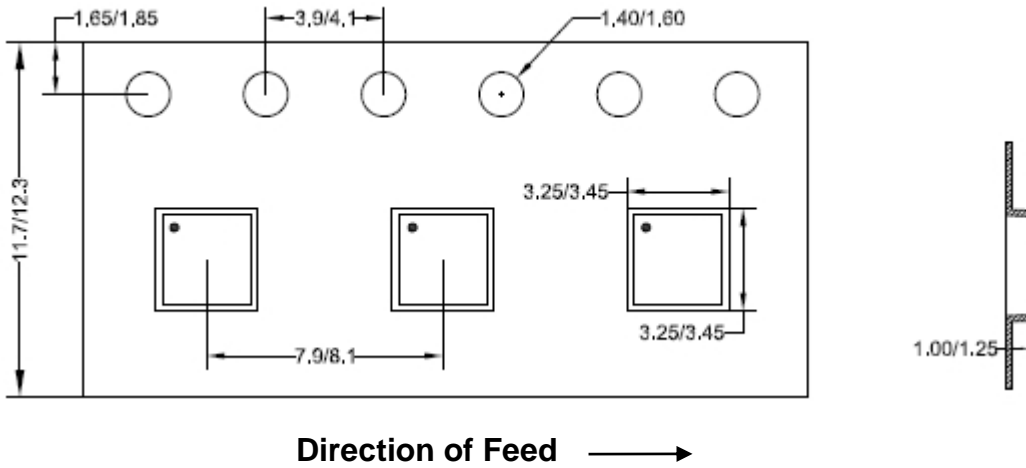

2. Reel dimensions

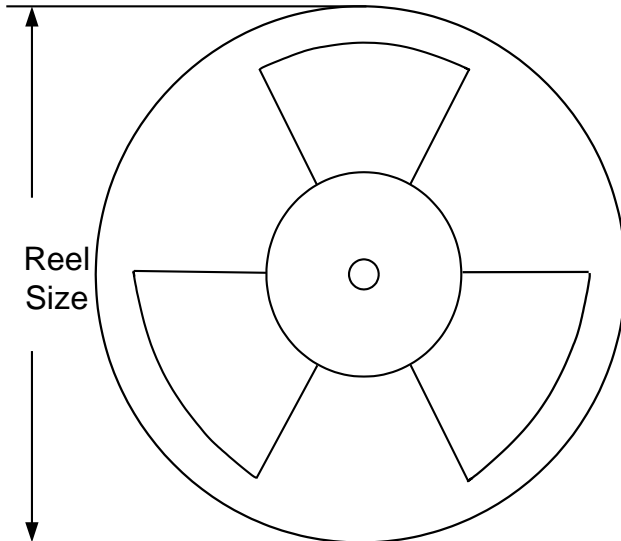

Package type	Tape width (mm)	Pocket pitch(mm)	Reel size (Inch)	Trailer length(mm)	Leader length (mm)	Qty per reel
DFN3x3	12	8	13"	400	400	5000

Revision History

The revision history provided is for informational purpose only and is believed to be accurate, however, not warranted. Please make sure that you have the latest revision.

Date	Revision	Change
Oct. 08, 2024	Revision 1.0B	<ol style="list-style-type: none">1. Update the Description of Slew Rate Control (page 10)2. C4 changed from 100nF to 10nF in BOM list (page 12)
May 20, 2024	Revision 1.0A	<ol style="list-style-type: none">3. Add Note 5 (Guaranteed by design, not production test.) for Thermal Shutdown Threshold/ Thermal Shutdown Hysteresis/ Short-Circuit Protection Trip Current (Page 4);4. Update the description of Power Sequencing (page 10);5. Update the package outline (page13)
Jan.05, 2024	Revision 1.0	Initial Release

IMPORTANT NOTICE

1. **Right to make changes.** Silergy and its subsidiaries (hereafter Silergy) reserve the right to change any information published in this document, including but not limited to circuitry, specification and/or product design, manufacturing or descriptions, at any time and without notice. This document supersedes and replaces all information supplied prior to the publication hereof. Buyers should obtain the latest relevant information before placing orders and should verify that such information is current and complete. All semiconductor products are sold subject to Silergy's standard terms and conditions of sale.
2. **Applications.** Application examples that are described herein for any of these products are for illustrative purposes only. Silergy makes no representation or warranty that such applications will be suitable for the specified use without further testing or modification. Buyers are responsible for the design and operation of their applications and products using Silergy products. Silergy or its subsidiaries assume no liability for any application assistance or designs of customer products. It is customer's sole responsibility to determine whether the Silergy product is suitable and fit for the customer's applications and products planned. To minimize the risks associated with customer's products and applications, customer should provide adequate design and operating safeguards. Customer represents and agrees that it has all the necessary expertise to create and implement safeguards which anticipate dangerous consequences of failures, monitor failures and their consequences, lessen the likelihood of failures that might cause harm and take appropriate remedial actions. Silergy assumes no liability related to any default, damage, costs or problem in the customer's applications or products, or the application or use by customer's third-party buyers. Customer will fully indemnify Silergy, its subsidiaries, and their representatives against any damages arising out of the use of any Silergy components in safety-critical applications. It is also buyers' sole responsibility to warrant and guarantee that any intellectual property rights of a third party are not infringed upon when integrating Silergy products into any application. Silergy assumes no responsibility for any said applications or for any use of any circuitry other than circuitry entirely embodied in a Silergy product.
3. **Limited warranty and liability.** Information furnished by Silergy in this document is believed to be accurate and reliable. However, Silergy makes no representation or warranty, expressed or implied, as to the accuracy or completeness of such information and shall have no liability for the consequences of use of such information. In no event shall Silergy be liable for any indirect, incidental, punitive, special or consequential damages, including but not limited to lost profits, lost savings, business interruption, costs related to the removal or replacement of any products or rework charges, whether or not such damages are based on tort or negligence, warranty, breach of contract or any other legal theory. Notwithstanding any damages that customer might incur for any reason whatsoever, Silergy' aggregate and cumulative liability towards customer for the products described herein shall be limited in accordance with the Standard Terms and Conditions of Sale of Silergy.
4. **Suitability for use.** Customer acknowledges and agrees that it is solely responsible for compliance with all legal, regulatory and safety-related requirements concerning its products, and any use of Silergy components in its applications, notwithstanding any applications-related information or support that may be provided by Silergy. Silergy products are not designed, authorized or warranted to be suitable for use in life support, life-critical or safety-critical systems or equipment, nor in applications where failure or malfunction of a Silergy product can reasonably be expected to result in personal injury, death or severe property or environmental damage. Silergy assumes no liability for inclusion and/or use of Silergy products in such equipment or applications and therefore such inclusion and/or use is at the customer's own risk.
5. **Terms and conditions of commercial sale.** Silergy products are sold subject to the standard terms and conditions of commercial sale, as published at <http://www.silergy.com/stdterms>, unless otherwise agreed in a valid written individual agreement specifically agreed to in writing by an authorized officer of Silergy. In case an individual agreement is concluded only the terms and conditions of the respective agreement shall apply. Silergy hereby expressly objects to and denies the application of any customer's general terms and conditions with regard to the purchase of Silergy products by the customer.
6. **No offer to sell or license.** Nothing in this document may be interpreted or construed as an offer to sell products that is open for acceptance or the grant, conveyance or implication of any license under any copyrights, patents or other industrial or intellectual property rights. Silergy makes no representation or warranty that any license, either express or implied, is granted under any patent right, copyright, mask work right, or other intellectual property right. Information published by Silergy regarding third-party products or services does not constitute a license to use such products or services or a warranty or endorsement thereof. Use of such information may require a license from a third party under the patents or other intellectual property of the third party, or a license from Silergy under the patents or other intellectual property of Silergy.

For more information, please visit: www.silergy.com

© 2024 Silergy Corp.

All Rights Reserved.