

Programmable High Current Protection Switch With Integrated Reverse Blocking FET

General Description

The SY20818 is a programmable current limit switch with output voltage clamping. Extremely low $R_{DS(ON)}$ of the integrated protection N-channel FET helps to reduce power loss during normal operation. The programmable soft-start time controls the slew rate of the output voltage during the start-up time.

The SY20818 is available in a compact QFN 2mmx2mm-9pin package.

Features

- Input Voltage Range: 2.7V to 5.5V with Surge Up to 15V
- 5A Output Current Capability
- Extremely Low Power Path Resistance R_{PWPT}
 - $R_{PWPT}=30m\Omega$ (typ) at 3V V_{in} Conditions
- Reverse Blocking Function
- Programmable Current Limit
- Programmable Soft-Start Time
- Selectable Clamping Output Voltage Threshold
- Power Good Indicator Pin for Operation Status
- FLG Indicator Pin for Input Voltage Status
- RoHS Compliant and Halogen Free
- Compact package: QFN2x2-9

Applications

- SSD M.2 from Factor
- SSD Dual Input Power Applications
- SSD Load Switch

Typical Application Circuit

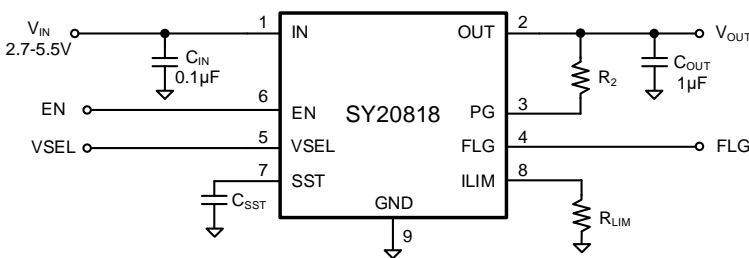

Figure 1. Schematic Diagram

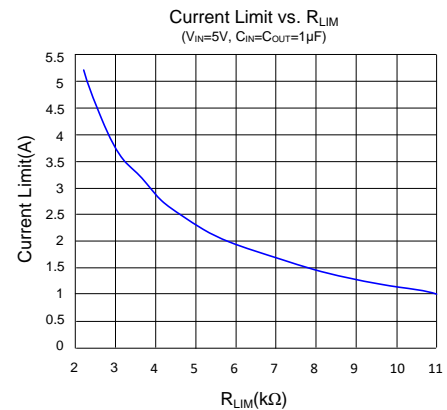

Figure 2. Current Limit vs. R_{LIM}

Ordering Information

Ordering Number	Package Type	Top Mark
SY20818RYC	QFN2x2-9 RoHS Compliant and Halogen Free	Udxyz

Device code: Ud

x=year code, y=week code, z= lot number code

Pinout (Top View)

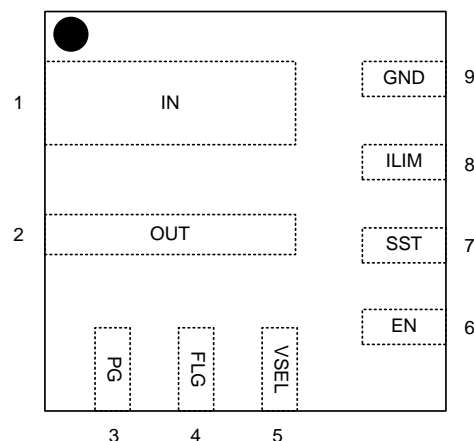

(QFN2x2-9)

Pin Name	Pin Number	Pin Description																		
IN	1	Power input pin. Decouple high frequency noise by connecting at least a 0.1μF MLCC to the ground.																		
OUT	2	Output voltage pin.																		
EN	6	Pull high to enable SY20818. Do not leave it floating.																		
VSEL	5	Output clamp voltage selection based on the input voltage. Pull the VSEL pin high by connecting a resistor to IN, or pull the VSEL pin low by connecting a resistor to the ground. <table border="1" data-bbox="521 1150 1446 1276"> <thead> <tr> <th rowspan="2">VSEL</th> <th rowspan="2">V_{IN}</th> <th colspan="3">Clamping Threshold</th> </tr> <tr> <th>Min</th> <th>Typ</th> <th>Max</th> </tr> </thead> <tbody> <tr> <td>LOW</td> <td>3.3V</td> <td>3.6V</td> <td>3.8V</td> <td>4V</td> </tr> <tr> <td>HIGH</td> <td>5V</td> <td>5.4V</td> <td>5.7V</td> <td>6V</td> </tr> </tbody> </table>	VSEL	V _{IN}	Clamping Threshold			Min	Typ	Max	LOW	3.3V	3.6V	3.8V	4V	HIGH	5V	5.4V	5.7V	6V
VSEL	V _{IN}	Clamping Threshold																		
		Min	Typ	Max																
LOW	3.3V	3.6V	3.8V	4V																
HIGH	5V	5.4V	5.7V	6V																
ILIM	8	Input current limit program pin. Connect a resistor between this pin and GND to program input current limit.																		
SST	7	Soft-start time program pin. Connect a capacitor to the ground to program the soft start time. 600μs (typ.) for NC condition.																		
PG	3	Open drain indicator pin. PG is pulled high when the output voltage is stable in the normal range.																		
FLG	4	Open drain indicator pin. FLG is pulled down when the input voltage is larger than UVLO.																		
GND	9	Ground pin.																		

Block Diagram

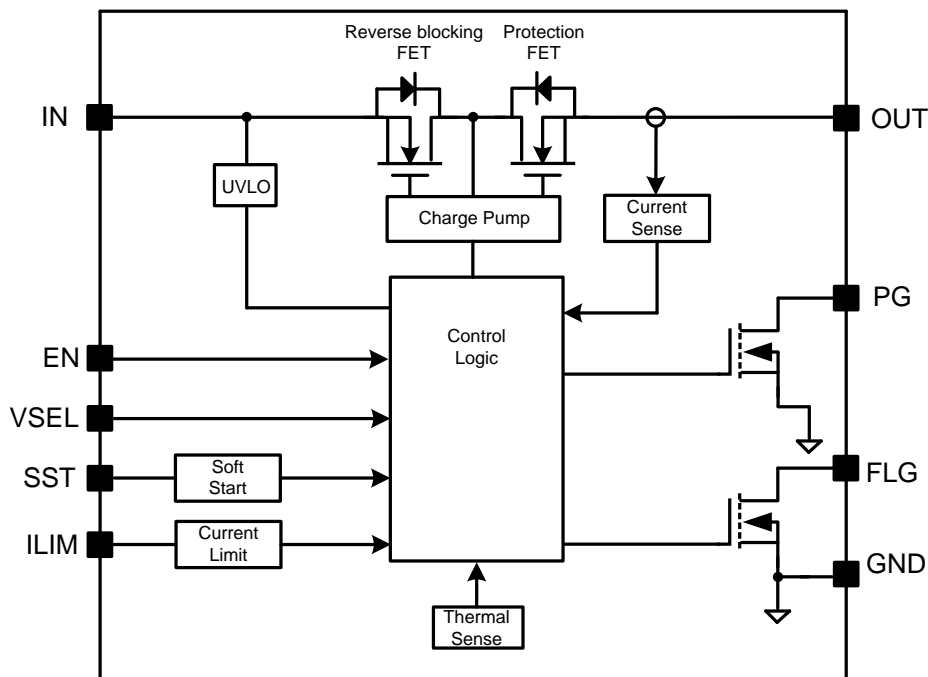

Figure 3. Block Diagram

Absolute Maximum Ratings

Parameter (Note 1)	Min	Max	Unit
IN, VSEL, EN, PG, FLG	-0.3	18	V
OUT	-0.3	7	
SST, ILIM	-0.3	3.6	
Lead Temperature (Soldering, 10s)		260	°C
Junction Temperature, Operating	-40	150	
Storage Temperature	-65	150	

Thermal Information

Parameter (Note 2)	Typ	Unit
θ_{JA} Junction-to-Ambient Thermal Resistance	38.5	°C/W
θ_{JC} Junction-to-Case Thermal Resistance	11.5	
P_D Power Dissipation $T_A = 25^\circ\text{C}$	2.6	W

Recommended Operating Conditions

Parameter (Note 3)	Min	Max	Unit
IN	2.7	5.5	V
VSEL, EN, PG, FLG	0	5.5	
SST, ILIM	0	3.3	
Junction Temperature, Operating	-40	125	°C



Electrical Characteristics

($V_{IN} = 2.7V$ to $5.5V$, $C_{IN}=0.1\mu F$, $C_{OUT}=1\mu F$, $T_A = 25^\circ C$, unless otherwise specified)

Parameter	Symbol	Test Conditions	Min	Typ	Max	Unit
Input Voltage Range	V_{IN}		2.7		5.5	V
Input UVLO Threshold	V_{UVLO}				2.6	V
UVLO hysteresis	V_{HYS}			0.1		V
Shut Down Current	I_{SD}	EN=0		10		μA
Bias Current	I_{BIAS}			50		μA
Clamping Output Voltage	V_{CLP}	$V_{SEL}=LOW$	3.6	3.8	4.0	V
		$V_{SEL}=HIGH$	5.4	5.7	6.0	V
VSEL High Threshold	V_{SEL_HI}		1			V
VSEL Low Threshold	V_{SEL_LO}				0.4	V
EN High Threshold	V_{ENH}		1			V
EN Low Threshold	V_{ENL}				0.4	V
Resistance of Power Path	R_{PWPT}	$V_{IN}=3V$, $I_{OUT}=200mA$, from IN to OUT		30		m Ω
Reverse Blocking Threshold	V_{RBT}			50		mV
Soft start Time Program Range	t_{SST}	$C_{SST}=100nF$ (Note 4)		23		ms
Soft-start Time Accuracy			-30%		30%	t_{SST}
Current Limit Program Range	I_{LIM}	(Note 5)	1		5	A
Current Limit Accuracy		$I_{LMT} = 2A$	-10%		10%	I_{LIM}
PG Low Voltage	V_{PGL}	$V_{IO}=3.3V$, $I_{SINK}=1mA$			0.2	V
PG Leakage Current	V_{PGLK}	$V_{IO}=3.3V$, PG high impedance			1	μA
FLG Low Voltage	V_{FAL}	$V_{IO}=3.3V$, $I_{SINK}=1mA$			0.2	V
FLG Leakage Current	V_{FALK}	$V_{IO}=3.3V$, FLG high impedance			1	μA
Thermal Shutdown Temperature	T_{SD}			150		$^\circ C$
Thermal Shutdown Hysteresis	T_{HYS}			20		$^\circ C$

Note 1: Stresses beyond the “Absolute Maximum Ratings” may cause permanent damage to the device. These are stress ratings only. Functional operation of the device at these or any other conditions beyond those indicated in the operational sections of the specification is not implied. Exposure to absolute maximum rating conditions for extended periods may affect device reliability.

Note 2: θ_{JA} is measured in the natural convection at $T_A = 25^\circ C$ on the Silergy Evaluation Board.

Note 3: The device is not guaranteed to function outside its operating conditions.

Note 4: Recommended Soft-Start Time Program Table:

SST cap (nF)	None	10	47	100
Rise time (ms)	0.6	2.3	10.8	23

Recommended formulas for C_{SST} and soft-start time calculations. Use the following formula if there is no external C_{SST} :

$$t_{SS} = t_{SS_DLT}$$

Use the following equation if a longer soft-start time is needed:



$$t_{SS} = \frac{0.85 \times C_{SST}}{I_{INT}}, t_{SS} > t_{SS_DLT}$$

Where, t_{SS_DLT} is the internally fixed default soft-start time of 0.6ms (typ.), when no external C_{SST} capacitor is used; I_{INT} is the internal current source, with a typical value of 3.7 μ A.

Note 5: Recommended Current Limit Program Table:

Current Limit Resistance (k Ω)	11	5.5	4.4	3.7	3.1	2.8	2.4	2.2
Current Limit (A)	1.0	2.0	2.5	3.0	3.5	4.0	4.5	5.0

Equation for R_{LIM} and current limit calculation:

$$R_{LIM} = \frac{11k}{I_{LIM}} (\Omega)$$

Typical Performance Characteristics

Quiescent Current vs. Input Voltage

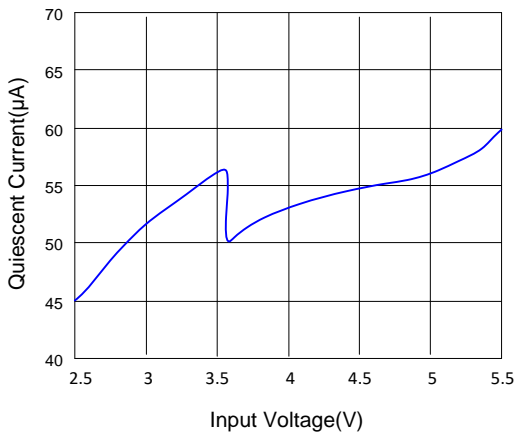

Shutdown Current vs. Input Voltage

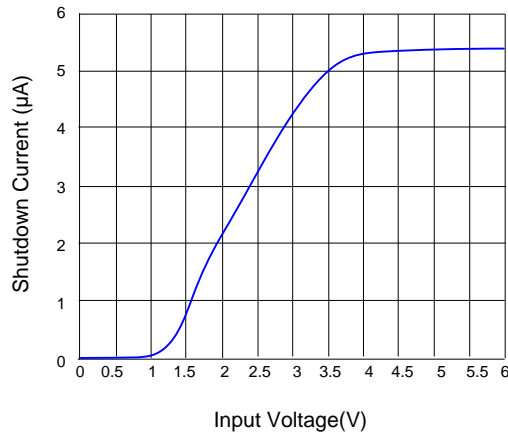

Current Limit vs. R_{LIM}
($V_{IN}=5V$, $C_{IN}=C_{OUT}=1\mu F$)

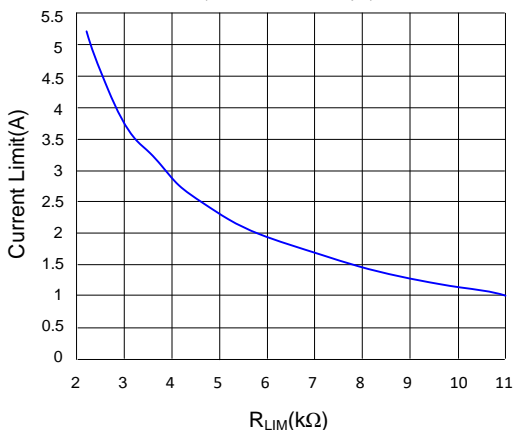

Output Voltage Vs. Current Limit
($V_{IN}=5V$, $C_{IN}=C_{OUT}=1\mu F$, $R_{SET}=2.2k\Omega$)

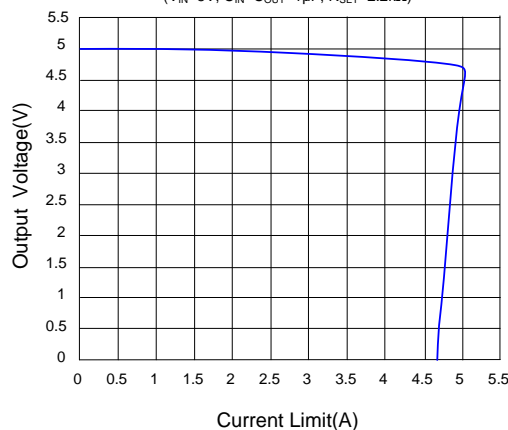

UVLO Threshold vs. Temperature

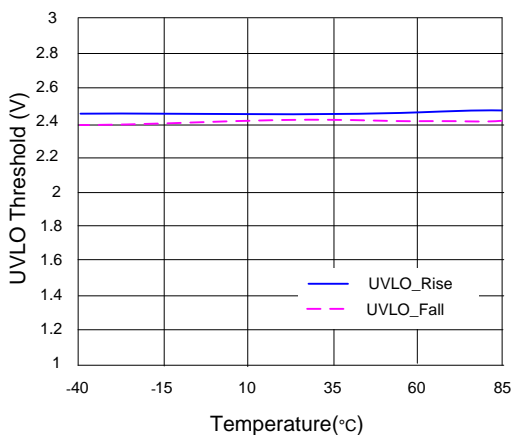

$R_{DS(ON)}$ vs. Temperature
($V_{IN}=5V$, $I_{LOAD}=0.5A$)

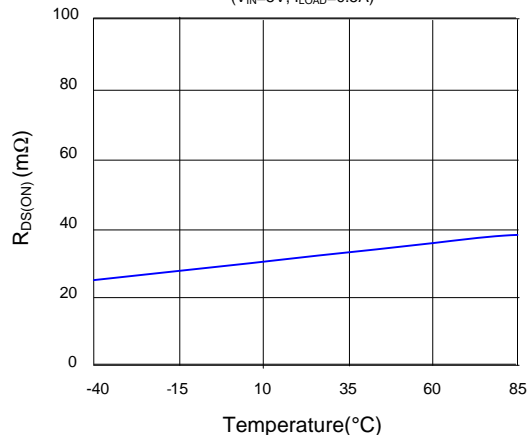

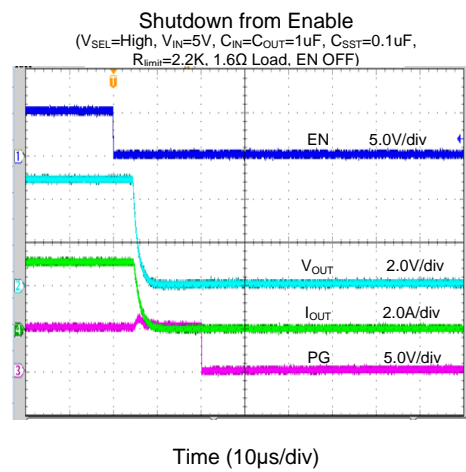
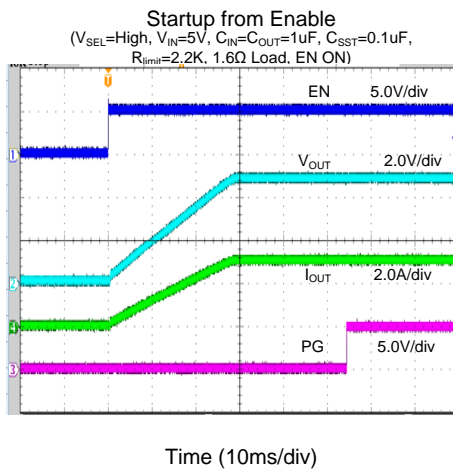
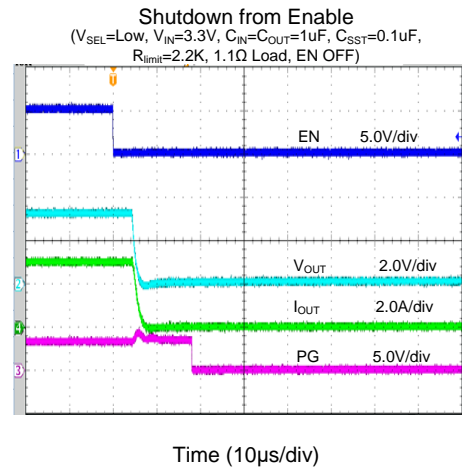
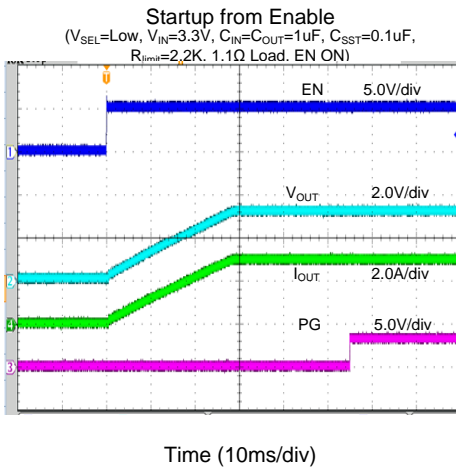
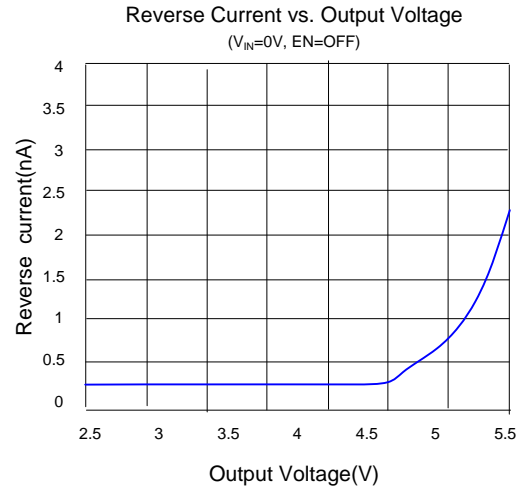
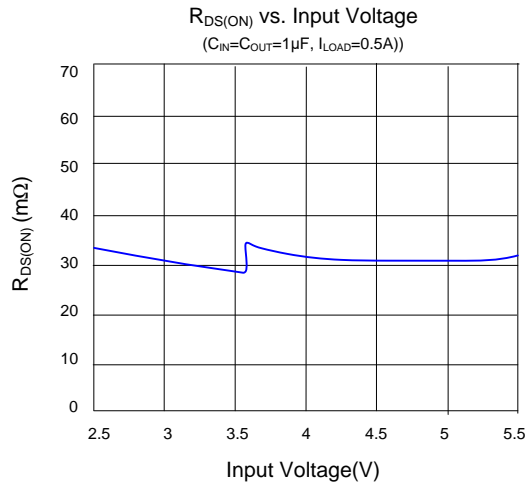

Reverse-Voltage Protection Response

($V_{IN}=5.5V$ to $5.0V$, $V_{OUT}=5.5V$, $EN=ON$, $C_{IN}=C_{OUT}=10\mu F$)

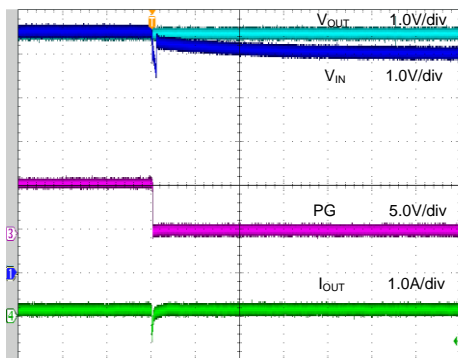

Time (800µs/div)

Reverse-Voltage Protection Recovery

($V_{IN}=5.0V$, $V_{OUT}=5.5V$ removed, $EN=ON$, $C_{IN}=C_{OUT}=10\mu F$, $R_L=10\Omega$)

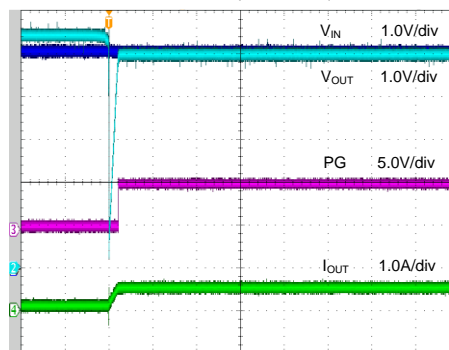

Time (100ms/div)

Short Circuit Response

($V_{SEL}=Low$, $V_{IN}=3.3V$, $C_{IN}=C_{OUT}=1\mu F$, C_{SST} Open)

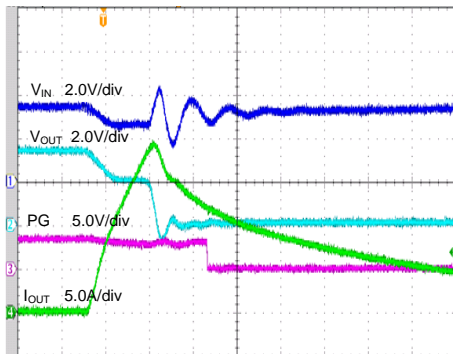

Time (1.00µs/div)

Short Circuit Response

($V_{SEL}=High$, $V_{IN}=5V$, $C_{IN}=C_{OUT}=1\mu F$, C_{SST} Open)

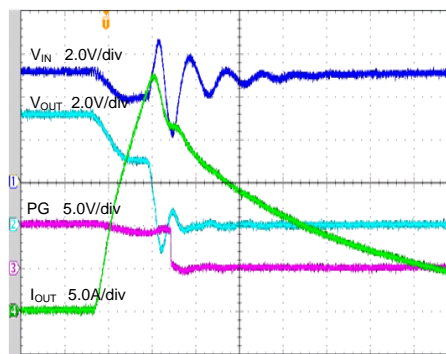

Time (1.00µs/div)

Clamp Protection Response

($V_{SEL}=High$, $V_{IN}=5V$ to $8V$, $C_{IN}=C_{OUT}=1\mu F$, Null Load)

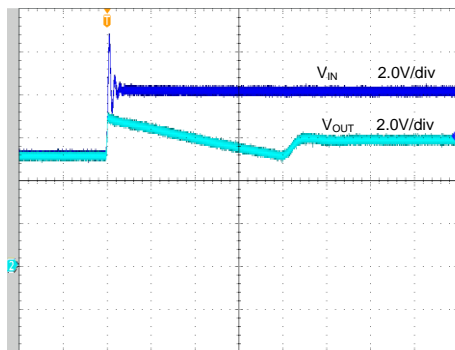

Time (40.0µs/div)



Application Information

The SY20818 is a current limited N-channel MOSFET power switch designed for high-side load-switching applications. It incorporates back-to-back N-channel MOSFETs to prevent current flow from OUT to IN when OUT is externally forced to a higher voltage than IN while the device is disabled.

Overcurrent Protection:

The SY20818 supports current limit programming. Connect a resistor R_{LIM} from the ILIM pin to the ground to program the current limit:

$$I_{LIM} = 11000 / R_{LIM} (\Omega)$$

The minimum current limit is 1A. A current limit beyond 5A is not recommended.

When an overcurrent condition is detected, the gate of the pass switch is controlled to achieve a constant output current. If the overcurrent condition persists for a long time, the junction temperature may exceed 150°C, and the overtemperature protection circuit will shut down the part. Once the chip temperature drops below 130°C, the part will restart.

Overvoltage Protection:

The SY20818 has an integrated overvoltage protection for the input pin. The output voltage is clamped at 5.7V (typ.) when $V_{SEL}=HIGH$, or the output voltage is clamped

at 3.8V (typ.) when $V_{SEL}=LOW$. The PG is driven low when the output voltage is clamped.

Supply Filter Capacitor:

A capacitor with a minimum value of 0.1 μF is required. In order to prevent input voltage dropping during hotplug events, a 1 μF ceramic capacitor from VIN to GND is strongly recommended. Higher capacitor values can further reduce input voltage drop. Without an input capacitor, an output short can cause ringing on the input, which could destroy the internal circuitry when the input transient exceeds the absolute maximum supply voltage, even for a short duration.

Output Filter Capacitor:

A 1 μF output ceramic capacitor is recommended to be placed close to the device and output connector to reduce voltage drop during load transient. Higher output capacitor values can further reduce the drop during high-current applications.

PCB Layout Guide:

For best performance of the SY20818, the following guidelines must be followed:

1. Keep all VBUS traces as short and wide as possible and use at least 2-ounce copper for all VBUS traces.
2. Place the output capacitor as close to the connectors as possible to lower the impedance and inductance between the port and the capacitor and improve transient performance.
3. Place the input and output capacitors close to the device and connect them to the ground plane to reduce noise coupling.

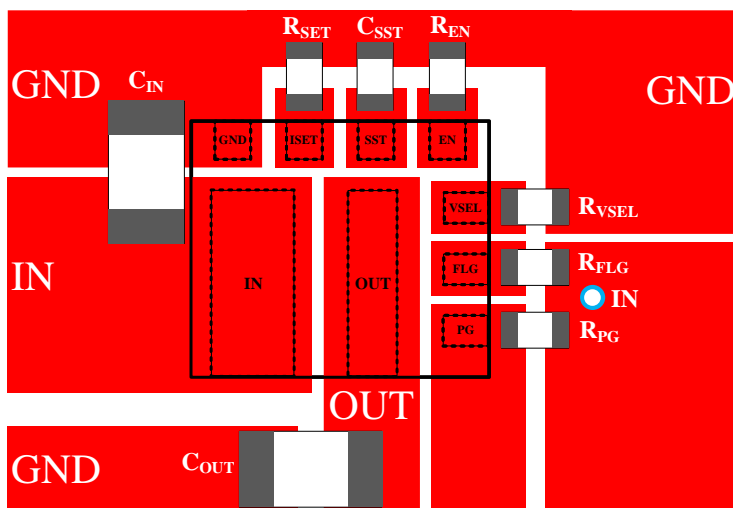
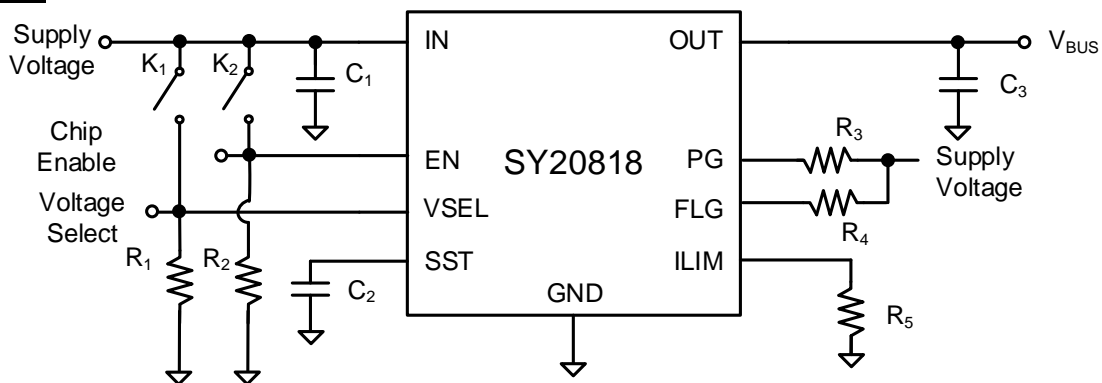

Figure 4. PCB Layout Suggestion



Schematic



BOM List

Reference Designator	Description	Part Number	Manufacturer
C ₁	1μF/50 V, 0603, X5R	C1608X5R1H105KT000N	TDK
C ₃	1μF/50 V, 0603, X5R	C1608X5R1H105KT000N	TDK
C ₂	100nF/6.3V, 0603, X5R	C1608X5R0J104KT000N	TDK
R ₁	1MΩ, 1%, 0603	RC0603FR-071ML	YAGEO
R ₂	1MΩ, 1%, 0603	RC0603FR-071ML	YAGEO
R ₃	100kΩ, 1%, 0603	RC0603FR-07100KL	YAGEO
R ₄	100kΩ, 1%, 0603	RC0603FR-07100KL	YAGEO
R ₅	2.2kΩ, 1%, 0603	RC0603FR-072K2L	YAGEO

QFN2x2-9 Package Outline & PCB Layout

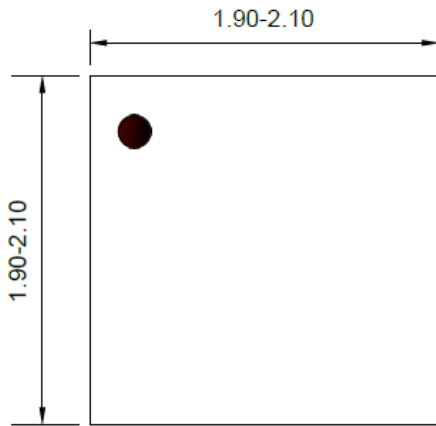

Top View

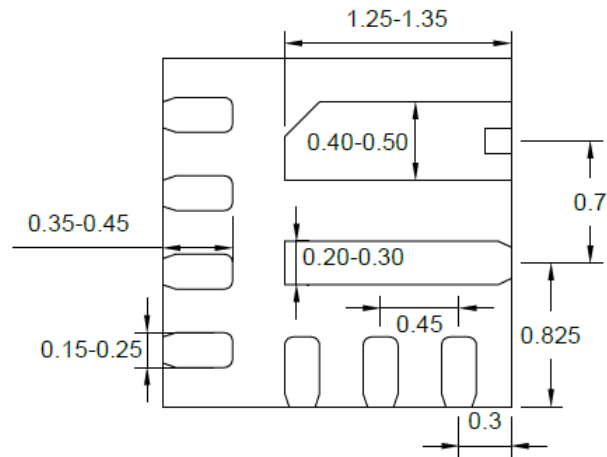

Bottom View

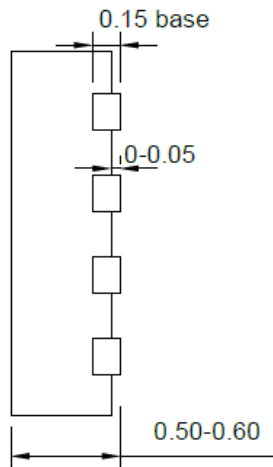

Side View

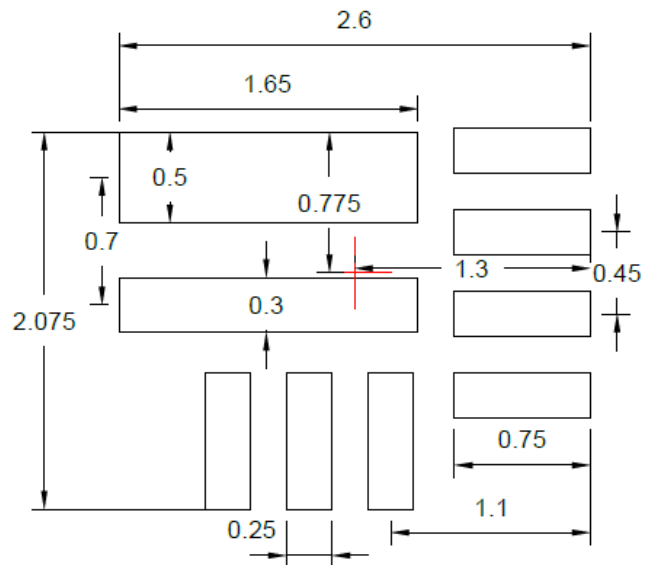

PCB Layout (Recommended)

Notes: 1. All dimensions are in millimeters and exclude mold flash and metal burr.
 2: The center of the PCB diagram refers to the chip center.

Taping & Reel Specification

1. QFN2x2 Taping Orientation

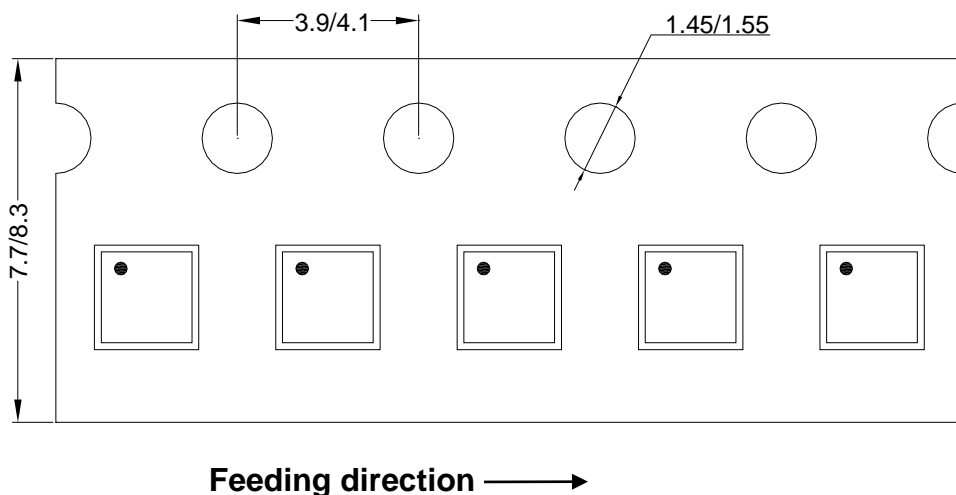

2. Carrier Tape & Reel Specification for Packages

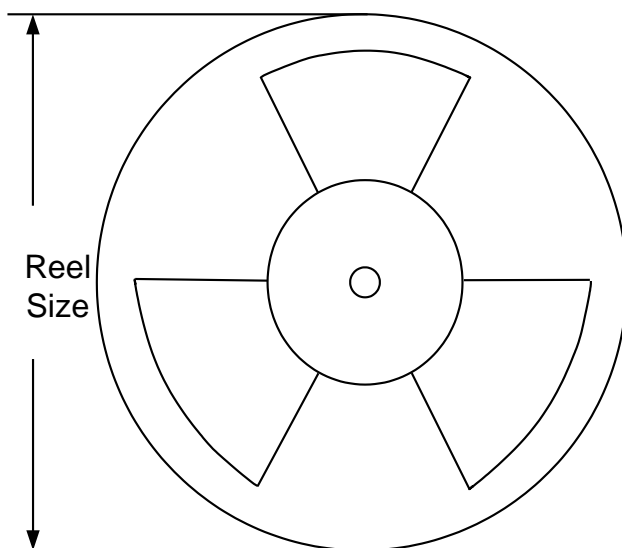

Package types	Tape width (mm)	Pocket pitch(mm)	Reel size (Inch)	Trailer length(mm)	Leader length (mm)	Qty per reel
QFN2x2	8	4	7"	400	160	3000

3. Others: NA

Revision History

The revision history provided is for informational purposes only and is believed to be accurate; however, it is not warranted. Please make sure that you have the latest revision.

Date	Revision	Change
Dec.12, 2023	Revision 1.0	Language improvements for clarity
Sep.03, 2018	Revision 0.9	Initial Release

IMPORTANT NOTICE

1. **Right to make changes.** Silergy and its subsidiaries (hereafter Silergy) reserve the right to change any information published in this document, including but not limited to circuitry, specification and/or product design, manufacturing or descriptions, at any time and without notice. This document supersedes and replaces all information supplied prior to the publication hereof. Buyers should obtain the latest relevant information before placing orders and should verify that such information is current and complete. All semiconductor products are sold subject to Silergy's standard terms and conditions of sale.
2. **Applications.** Application examples that are described herein for any of these products are for illustrative purposes only. Silergy makes no representation or warranty that such applications will be suitable for the specified use without further testing or modification. Buyers are responsible for the design and operation of their applications and products using Silergy products. Silergy or its subsidiaries assume no liability for any application assistance or designs of customer products. It is customer's sole responsibility to determine whether the Silergy product is suitable and fit for the customer's applications and products planned. To minimize the risks associated with customer's products and applications, customer should provide adequate design and operating safeguards. Customer represents and agrees that it has all the necessary expertise to create and implement safeguards which anticipate dangerous consequences of failures, monitor failures and their consequences, lessen the likelihood of failures that might cause harm and take appropriate remedial actions. Silergy assumes no liability related to any default, damage, costs or problem in the customer's applications or products, or the application or use by customer's third-party buyers. Customer will fully indemnify Silergy, its subsidiaries, and their representatives against any damages arising out of the use of any Silergy components in safety-critical applications. It is also buyers' sole responsibility to warrant and guarantee that any intellectual property rights of a third party are not infringed upon when integrating Silergy products into any application. Silergy assumes no responsibility for any said applications or for any use of any circuitry other than circuitry entirely embodied in a Silergy product.
3. **Limited warranty and liability.** Information furnished by Silergy in this document is believed to be accurate and reliable. However, Silergy makes no representation or warranty, expressed or implied, as to the accuracy or completeness of such information and shall have no liability for the consequences of use of such information. In no event shall Silergy be liable for any indirect, incidental, punitive, special or consequential damages, including but not limited to lost profits, lost savings, business interruption, costs related to the removal or replacement of any products or rework charges, whether or not such damages are based on tort or negligence, warranty, breach of contract or any other legal theory. Notwithstanding any damages that customer might incur for any reason whatsoever, Silergy' aggregate and cumulative liability towards customer for the products described herein shall be limited in accordance with the Standard Terms and Conditions of Sale of Silergy.
4. **Suitability for use.** Customer acknowledges and agrees that it is solely responsible for compliance with all legal, regulatory and safety-related requirements concerning its products, and any use of Silergy components in its applications, notwithstanding any applications-related information or support that may be provided by Silergy. Silergy products are not designed, authorized or warranted to be suitable for use in life support, life-critical or safety-critical systems or equipment, nor in applications where failure or malfunction of a Silergy product can reasonably be expected to result in personal injury, death or severe property or environmental damage. Silergy assumes no liability for inclusion and/or use of Silergy products in such equipment or applications and therefore such inclusion and/or use is at the customer's own risk.
5. **Terms and conditions of commercial sale.** Silergy products are sold subject to the standard terms and conditions of commercial sale, as published at <http://www.silergy.com/stdterms>, unless otherwise agreed in a valid written individual agreement specifically agreed to in writing by an authorized officer of Silergy. In case an individual agreement is concluded only the terms and conditions of the respective agreement shall apply. Silergy hereby expressly objects to and denies the application of any customer's general terms and conditions with regard to the purchase of Silergy products by the customer.
6. **No offer to sell or license.** Nothing in this document may be interpreted or construed as an offer to sell products that is open for acceptance or the grant, conveyance or implication of any license under any copyrights, patents or other industrial or intellectual property rights. Silergy makes no representation or warranty that any license, either express or implied, is granted under any patent right, copyright, mask work right, or other intellectual property right. Information published by Silergy regarding third-party products or services does not constitute a license to use such products or services or a warranty or endorsement thereof. Use of such information may require a license from a third party under the patents or other intellectual property of the third party, or a license from Silergy under the patents or other intellectual property of Silergy.

For more information, please visit: www.silergy.com

© 2018 Silergy Corp.

All Rights Reserved.