

**W83877ATF**  
**WINBOND I/O**



## WINBOND I/O

### GENERAL DESCRIPTION

The W83877ATF is an enhanced version from Winbond's most popular I/O chip W83877F --- which integrates the disk drive adapter, serial port (UART), IrDA 1.0 SIR, parallel port, configurable plug-and-play registers for the whole chip --- plus additional powerful features: **IrDA 1.1** (*MIR for 1.152M bps or FIR for 4M bps*), TV remote IR, **ACPI**, serial IRQ, **full 16-bit address decoding**, and **ACPI compliant**.

The disk drive adapter functions of W83877ATF include a floppy disk drive controller compatible with the industry standard 82077/765, data separator, write pre-compensation circuit, decode logic, data rate selection, clock generator, drive interface control logic, and interrupt and DMA logic. The wide range of functions integrated onto the W83877ATF greatly reduces the number of components required for interfacing with floppy disk drives. The W83877ATF supports four 360K, 720K, 1.2M, 1.44M, or 2.88M disk drives and data transfer rates of 250 Kb/S, 300 Kb/S, 500 Kb/S, 1 Mb/S, and 2 Mb/S.

The W83877ATF provides two high-speed serial communication ports (UARTs), one of which supports serial Infrared communication. Each UART includes a 16-byte send/receive FIFO, a programmable baud rate generator, complete modem control capability, and a processor -interrupt system. One of the UARTs supporting infrared (IR) includes 32-byte FIFO, serial IR, 1.152M bps MIR, 0.576M bps, 4M bps FIR, and TV remote IR (supporting NEC, RC-5, extended RC-5, and RECS-80 protocols). Both UARTs provide legacy speed with baud rate 115.2k, and provide advanced speed with baud rate **230k**, **460k**, and **921k bps** which support higher speed Modems.

The W83877ATF supports one PC-compatible printer port (SPP), Bi-directional Printer port (BPP) and also Enhanced Parallel Port (EPP) and Extended Capabilities Port (ECP). Through the printer port interface pins, also available are: Extension FDD Mode and Extension 2FDD Mode allowing one or two external floppy disk drives to be connected to the notebook computer.

Winbond W83877ATF provides functions that comply with **ACPI** (*Advanced Configuration and Power Interface*), which includes support of legacy and ACPI power management through  $\overline{\text{SMI}}$  or  $\overline{\text{SCI}}$  function pins. One 24-bit power management timer is implemented with carry notify interrupt. W83877ATF also has auto power management to reduce power consumption.

The **Serial IRQ** for PCI architecture is supported, ISA IRQs (IRQ1~IRQ15) can be cascaded into one IRQ pin. W83877ATF also features ISA bus IRQ sharing and allows two or more devices to share the same IRQ.

W83877ATF is made to fully comply with **Microsoft™ PC97 Hardware Design Guide**. IRQs, DMAs, and I/O space resource are flexible to adjust to meet ISA PnP requirements. Moreover, W83877ATF is made to meet the specification of PC97's requirement in the power management: **ACPI** and **DPM** (Device Power Management).

The configuration registers support mode selection, function enable/disable, and power down function selection. Furthermore, the configurable PnP features are compatible with the plug-and-play feature demand of Windows 95™, which makes system resource allocation more efficient than ever.

Another benefit is that W83877ATF has the same pin assignment as W83877F, W83877AF, W83877TF. This makes the design very flexible.

## FEATURES

### General:

- Plug & Play 1.0A Compliant
- Support 8 IRQs (ISA), or 15 IRQs (Serial IRQ), 4 DMA channels, and 480 Relocatable addresses
- Capable of ISA Bus IRQ Sharing
- Compliant with **Microsoft™ PC97** Hardware Design Guide
- Support **DPM** (Device Power Management), **ACPI**
- Report ACPI status interrupt by **nSCI** signal from serial IRQ pin, or from IRQ A~H pins
- Single 24M or 48M Hz crystal input

### FDC:

- Compatible with IBM™ PC AT disk drive systems
- Variable write pre-compensation with track selectable capability
- DMA enable logic
- Support floppy disk drives and tape drives
- Detects all overrun and underrun conditions
- Built-in address mark detection circuit to simplify the read electronics
- FDD anti-virus functions with software write protect and FDD write enable signal (write data signal is forced to be inactive)
- Support up to four 3.5-inch or 5.25-inch floppy disk drives
- Completely compatible with industry standard 82077
- 360K/720K/1.2M/1.44M/2.88M format; 250K, 300K, 500K, 1M, 2M bps data transfer rate
- Support vertical recording format
- **Support 3-mode FDD, and its Windows95™ driver**
- 16-byte data FIFOs

### UART:

- Two high-speed 16550 compatible UARTs with 16-byte send/receive FIFOs
- MIDI compatible
- Fully programmable serial-interface characteristics:
  - 5, 6, 7 or 8-bit characters
  - Even, odd or no parity bit generation/detection
  - 1, 1.5 or 2 stop bits generation

- Internal diagnostic capabilities:
  - Loop-back controls for communications link fault isolation
  - Break, parity, overrun, framing error simulation
- Programmable baud generator allows division of 1.8461 M Hz and 24 MHz by 1 to  $(2^{16}-1)$
- Maximum baud rate up to 921k bps for 14.768M Hz and 1.5M bps for 24M Hz

#### Infrared:

- Support IrDA version 1.0 SIR protocol with maximum baud rate up to 115.2K bps
- Support SHARP ASK-IR protocol with maximum baud rate up to 57,600 bps
- Support IrDA version 1.1 MIR (1.152M bps) and FIR (4M bps) protocol
  - Single DMA channel for transmitter or receiver
  - 32-byte FIFO is supported in both FIR TX/RX transmission
  - 8-byte status FIFO is supported to store received frame status (such as overrun, CRC error, etc.)
- Support auto-config SIR and FIR
- Support full Customer IR
- Support driver for [Microsoft™](#) Windows 95™ and Windows 98™ (Memphis™)

#### Parallel Port:

- Compatible with IBM™ parallel port
- Support PS/2 compatible bi-directional parallel port
- Support Enhanced Parallel Port (EPP) – Compatible with IEEE 1284 specification
- Support Extended Capabilities Port (ECP) – Compatible with IEEE 1284 specification
- Extension FDD mode supports disk drive B and Extension 2FDD mode supports disk drives A and B through parallel port
- Enhanced printer port back-drive current protection

#### Others:

- Programmable configuration settings
- Immediate or automatic power-down mode for power management
- All hardware power-on settings have internal pull-up or pull-down resistors as default value
- Full 16-bit address decode (UART B pin option)
- PNF pin (Printer-Not-Floppy pin) for distinguishing printer port connection --- FDD or Printer; unique for notebook application of external floppy through printer port

#### Package:

- 100-pin QFP (W83877ATF), and also 100-pin TQFP (W83877ATD)

**PIN CONFIGURATION**

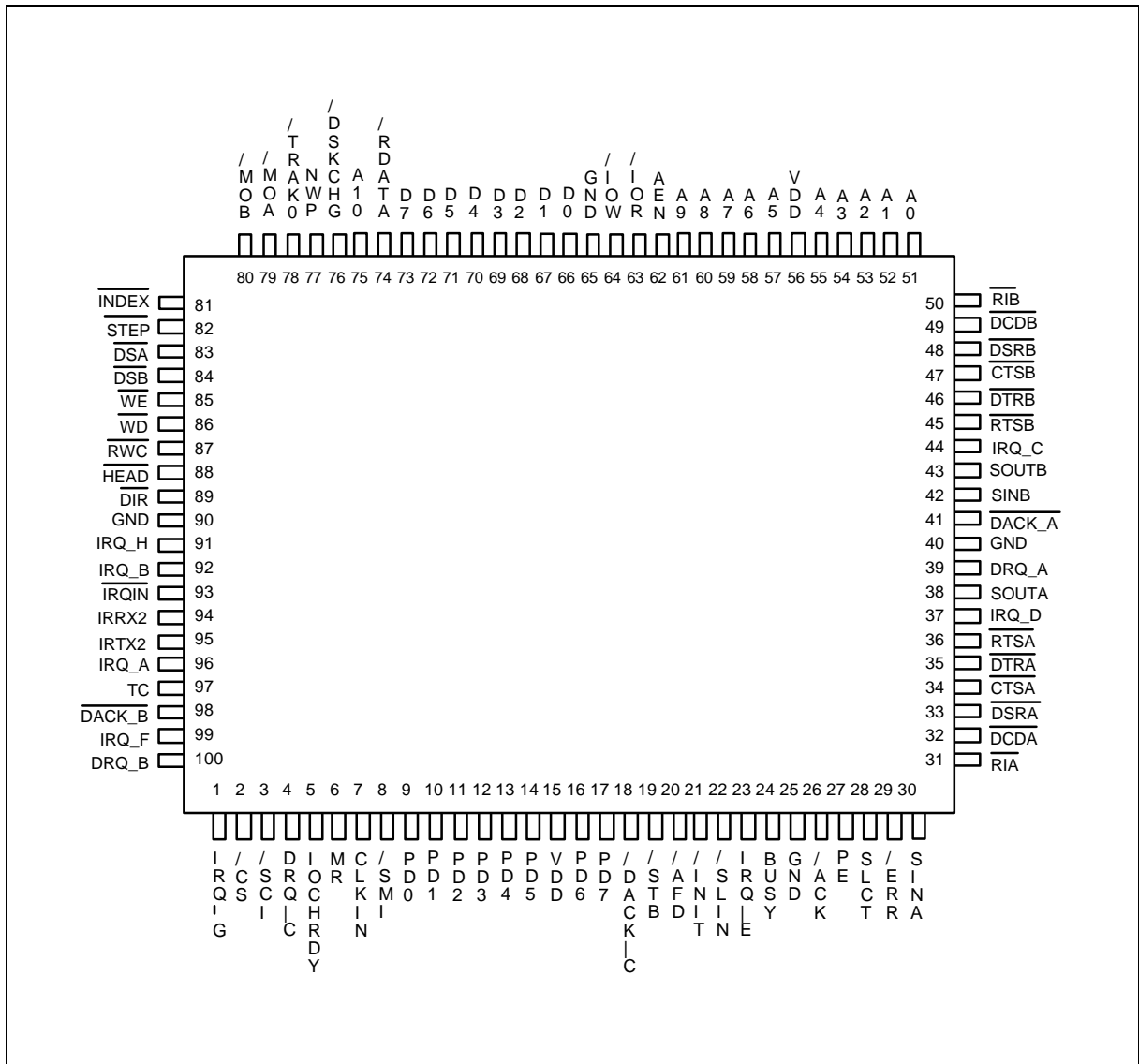

## 1.0 PIN DESCRIPTION

Note: Refer to section 9.2 DC CHARACTERISTICS for details.

I/O<sub>8tc</sub> - TTL level output pin with 8 mA source-sink capability; CMOS level input voltage

I/O<sub>12t</sub> - TTL level bi-directional pin with 12 mA source-sink capability

I/O<sub>12ts</sub> - TTL level bi-directional pin with 12 mA source-sink capability and Schmitt-triggered input

I/O<sub>24t</sub> - TTL level bi-directional pin with 24 mA source-sink capability

OUT<sub>8t</sub> - TTL level output pin with 8 mA source-sink capability

OUT<sub>12t</sub> - TTL level output pin with 12 mA source-sink capability

OD<sub>12</sub> - Open-drain output pin with 12 mA sink capability

OD<sub>24</sub> - Open-drain output pin with 24 mA sink capability

IN<sub>t</sub> - TTL level input pin

IN<sub>ts</sub> - TTL level Schmitt-triggered input pin

IN<sub>cs</sub> - CMOS level Schmitt-triggered input pin

## 1.1 HOST INTERFACE

SYMBOL	PIN	I/O	FUNCTION
D0–D7	66-73	I/O <sub>24t</sub>	System data bus bits 0-7.
A0–A10	51-55 57-61 75	IN <sub>t</sub>	System address bus bits 0-10.
IOCHRDY	5	OD <sub>24</sub>	In EPP Mode, this pin is the I/O Channel Ready output to extend the host read/write cycle.
MR	6	IN <sub>ts</sub>	Master Reset. Active high. MR is low during normal operations.
$\overline{CS}$ A11	2	IN <sub>ts</sub> IN <sub>ts</sub>	Active low chip select signal. System address bus bit 11, when 16-bit address decoder is set to logic 0 in which <b>CR16.bit6</b> ( $\overline{ENI6SA}$ ).
AEN	62	IN <sub>t</sub>	System address bus enable.
$\overline{IOR}$	63	IN <sub>ts</sub>	CPU I/O read signal.
$\overline{IOW}$	64	IN <sub>ts</sub>	CPU I/O write signal.
$\overline{DACK\_A}$	41	IN <sub>ts</sub>	DMA acknowledge signal A.
DRQ_A	39	OUT <sub>8t</sub>	DMA request signal A.
DRQ_B	100	OUT <sub>12t</sub>	DMA request signal B.
$\overline{DACK\_B}$	98	IN <sub>ts</sub>	DMA acknowledge signal B.

**1.1 Host Interface, continued**

<b>SYMBOL</b>	<b>PIN</b>	<b>I/O</b>	<b>FUNCTION</b>
DRQ_C	4	OUT <sub>12t</sub>	DMA request signal C.
$\overline{\text{DACK\_C}}$	18	IN <sub>ts</sub>	DMA acknowledge signal C.
IRQIN DRQ_D IRSL2 IRRXH/IRSL0  PNF	93	IN <sub>ts</sub> OUT <sub>12t</sub> OUT <sub>12t</sub> I/O <sub>12ts</sub>  IN <sub>ts</sub>	Interrupt request input. DMA request signal D. IR module mode selection 2. When input, acts as a function of high speed IR receiving terminal. When output selected, acts as a IR module mode selection 0. Detects printer is active, and not external FDC. When this pin PNF is detected to 1 signal, the device is switched to parallel printer. When this pin PNF is detected to 0 signal, the device is switched to external FDC. The pin is configured in <b>CR16.bit7 (ENPNF)</b> .
IRRXH/IRSL0  $\overline{\text{DACK\_D}}$ IRSL1	3	I/O <sub>12ts</sub>  IN <sub>ts</sub> OUT <sub>12t</sub>	When input pin, high speed IR received terminal. When output pin, IR module mode select 0. Input or output are defined in high speed IR register. DMA acknowledge signal for channel D. IR module mode select 1.
TC	97	IN <sub>ts</sub>	Terminal Count. When active, this pin indicates termination of a DMA transfer.
IRQ_A  $\overline{\text{SCI}}$ GIO1	96	OUT <sub>12t</sub> OUT <sub>12t</sub> I/O <sub>12t</sub>	When CR16 Bit 5 (GOIQSEL) = 0: Interrupt request signal A. ACPI interrupt signal, selected by PnP IRQ configure register. When CR16 Bit 4 (GOIQSEL) = 1: General Purpose I/O port 1.
IRQ_B GIO0	92	OUT <sub>12t</sub> I/O <sub>12t</sub>	When CR16 Bit 4 (GOIQSEL) = 0: Interrupt request signal B. When CR16 Bit 4 (GOIQSEL) = 1: General Purpose I/O port 0.
IRQ_C	44	OUT <sub>12t</sub>	Interrupt request signal C.
IRQ_D	37	OUT <sub>12t</sub>	Interrupt request signal D.
IRQ_E	23	OUT <sub>12t</sub>	Interrupt request signal E.
IRQ_F	99	OUT <sub>12t</sub>	Interrupt request signal F.
IRQ_G DRQ_D IRSL2 PCICLK	1	OUT <sub>12t</sub> OUT <sub>12t</sub> OUT <sub>12t</sub> IN <sub>t</sub>	Interrupt request signal G. DMA request signal channel D. IR module mode select 2. PCI clock input when the serial IRQ function is selected.

**1.1 Host Interface, continued**

SYMBOL	PIN	I/O	FUNCTION
IRQ_H	91	OUT <sub>12t</sub>	Interrupt request signal H.
IRSL2		OUT <sub>12t</sub>	IR module mode selection 2.
$\overline{\text{DACK\_D}}$		IN <sub>ts</sub>	DMA acknowledge signal D.
SERIRQ		OUT <sub>12t</sub>	Serial Interrupt output, when the function of the serial IRQ is set to logic 1 defined in the <b>CR31.bit2 (IRQMODS)</b> .
CLKIN	7	IN <sub>t</sub>	24MHz/48MHz clock input. CLKINSEL bit in CR2C register should be correctly reset/set according to the input frequency.
$\overline{\text{SMI}}$	8	OUT <sub>12t</sub>	For the power management, the $\overline{\text{SMI}}$ is and active low by the power management events, that generate an nSCI in ACPI mode.

**1.2 Serial Port Interface**

SYMBOL	PIN	I/O	FUNCTION
$\overline{\text{CTSA}}$	34	IN <sub>t</sub>	Clear To Send is the modem control input.
$\overline{\text{CTSB}}$	47	IN <sub>t</sub>	Clear To Send is the modem control input.
A12		IN <sub>t</sub>	System address bus bit 12, when 16-bit address decoder is selected, that is, nEN16SA ( <b>CR16.bit6</b> ) is set to logic 0.
$\overline{\text{DSRA}}$	33	IN <sub>t</sub>	Data Set Ready. An active low indicates the modem or data set is ready to establish a communication link and transfer data to the UART.
$\overline{\text{DSRB}}$	48	IN <sub>t</sub>	Data Set Ready. An active low indicates the modem or data set is ready to establish a communication link and transfer data to the UART.
A13		IN <sub>t</sub>	System address bus bit 13, when 16-bit address decoder is selected.
$\overline{\text{DCDA}}$	32	IN <sub>t</sub>	Data Carrier Detect. An active low indicates the modem or data set has detected a data carrier.
$\overline{\text{DCDB}}$	49	IN <sub>t</sub>	Data Carrier Detect. An active low indicates the modem or data set has detected a data carrier.
A14		IN <sub>t</sub>	System address bus bit 14, when 16-bit address decoder is selected.
$\overline{\text{RIA}}$	31	IN <sub>t</sub>	Ring Indicator. An active low indicates that a ring signal is being received by the modem or data set.

**1.2 Serial Port Interface, continued**

SYMBOL	PIN	I/O	FUNCTION
RIB	50	IN <sub>t</sub>	Ring Indicator. An active low indicates that a ring signal is being received by the modem or data set.
A15		IN <sub>t</sub>	System address bus bit 15, when 16-bit address decoder is selected.
SINA	30	IN <sub>t</sub>	Serial Input of COM A. Used to receive serial data from the communication link.
SINB	42	IN <sub>t</sub>	Serial Input of COM B. Used to receive serial data from the communication link.
IRRX1		IN <sub>t</sub>	When infrared function is selected, acts as infrared input.
SOUTA	38	I/O <sub>8tc</sub>	UART A Serial Output. Used to transmit serial data out to the communication link.
PEN16SA		IN <sub>t</sub>	During power-on reset, this pin is pulled up internally and is defined as PEN16SA, which provides the power-on value for CR2E.bit6 (PEN16SA). A 4.7 kΩ is recommended when intending to pull down at power-on reset.
SOUTB	43	I/O <sub>12t</sub>	UART B Serial Output. Used to transmit serial data out to the communication link.
IRTX1		IN <sub>t</sub>	Infrared serial data output when COM B acts as infrared port.
DTRA	35	I/O <sub>8tc</sub>	UART A Data Terminal Ready. An active low informs the modem or data set that the controller is ready to communicate.
PHEFRAS		IN <sub>t</sub>	During power-on reset, this pin is pulled down internally and is defined as PHEFRAS, which provides the power-on value for CR16 bit 0 (HEFRAS), and Configuration Port is defined at 250h. A 4.7 kΩ is recommended when intending to pull up at power-on reset, and Configuration Port is defined at 3F0h.
DTRB	46	I/O <sub>8t</sub>	UART B Data Terminal Ready. An active low informs the modem or data set that controller is ready to communicate.
RTSA	36	I/O <sub>8tc</sub>	UART A Request To Send. An active low informs the modem or data set that the controller is ready to send data.
PPNPCVS		IN <sub>t</sub>	During power-on reset, this pin is pulled up internally and is defined as PPNPCVS, which provides the power-on value for CR16 bit 2 (PNPCVS). A 4.7 kΩ is recommended when intending to pull down at power-on reset.

**1.2 Serial Port Interface, continued**

SYMBOL	PIN	I/O	FUNCTION
$\overline{\text{RTSB}}$	45	I/O <sub>8tc</sub>	UART B Request To Send. An active low informs the modem or data set that the controller is ready to send data.
PGOIQSEL		IN <sub>t</sub>	During power-on reset, this pin is pulled down internally and is defined as PGOIQSEL, which provides the power-on value for CR16 bit 4 (GOIQSEL). A 4.7 k $\Omega$ is recommended when intending to pull up at power-on reset.
IRTX2	95	OUT <sub>12t</sub>	Function as a InfraRed transmission data line.
IRRX2	94	IN <sub>t</sub>	Function as a InfraRed receiving line.

**1.3 Multi-Mode Parallel Port**

The following pins have eight functions, which are controlled by bits PRTMOD0, PRTMOD1, and PRTMOD2 of CR0 and CR9 (refer to section 8.0, Extended Functions).

SYMBOL	PIN	I/O	FUNCTION
BUSY	24	IN <sub>t</sub>	<p>PRINTER MODE: BUSY</p> <p>An active high input indicates that the printer is not ready to receive data. This pin is pulled high internally. Refer to the description of the parallel port for the definition of this pin in ECP and EPP mode.</p>
		OD <sub>12</sub>	<p>EXTENSION FDD MODE: <math>\overline{\text{MOB2}}</math></p> <p>This pin is for Extension FDD B; the function of this pin is the same as that of the <math>\overline{\text{MOB}}</math> pin.</p>
		OD <sub>12</sub>	<p>EXTENSION 2FDD MODE: <math>\overline{\text{MOB2}}</math></p> <p>This pin is for Extension FDD A and B; the function of this pin is the same as that of the <math>\overline{\text{MOB}}</math> pin.</p>
$\overline{\text{ACK}}$	26	IN <sub>t</sub>	<p>PRINTER MODE: <math>\overline{\text{ACK}}</math></p> <p>An active low input on this pin indicates that the printer has received data and is ready to accept more data. This pin is pulled high internally. Refer to the description of the parallel port for the definition of this pin in ECP and EPP mode.</p>
		OD <sub>12</sub>	<p>EXTENSION FDD MODE: <math>\overline{\text{DSB2}}</math></p> <p>This pin is for the Extension FDD B; its functions are the same as those of the <math>\overline{\text{DSB}}</math> pin.</p>
		OD <sub>12</sub>	<p>EXTENSION 2FDD MODE: <math>\overline{\text{DSB2}}</math></p> <p>This pin is for Extension FDD A and B; the function of this pin is the same as that of the <math>\overline{\text{DSB}}</math> pin.</p>

**1.3 Multi-Mode Parallel Port, continued**

<b>SYMBOL</b>	<b>PIN</b>	<b>I/O</b>	<b>FUNCTION</b>
PE	27	IN <sub>t</sub>   OD <sub>12</sub>  OD <sub>12</sub>	<p>PRINTER MODE: PE</p> <p>An active high input on this pin indicates that the printer has detected the end of the paper. This pin is pulled high internally. Refer to the description of the parallel port for the definition of this pin in ECP and EPP mode.</p> <p>EXTENSION FDD MODE: <math>\overline{WD2}</math></p> <p>This pin is for Extension FDD B; its function is the same as that of the <math>\overline{WD}</math> pin.</p> <p>EXTENSION 2FDD MODE: <math>\overline{WD2}</math></p> <p>This pin is for Extension FDD A and B; the function of this pin is the same as that of the <math>\overline{WD}</math> pin.</p> <p>JOYSTICK MODE: NC pin.</p>
SLCT	28	IN <sub>t</sub>   OD <sub>12</sub>  OD <sub>12</sub>	<p>PRINTER MODE: SLCT</p> <p>An active high input on this pin indicates that the printer is selected. This pin is pulled high internally. Refer to the description of the parallel port for the definition of this pin in ECP and EPP mode.</p> <p>EXTENSION FDD MODE: WE2</p> <p>This pin is for Extension FDD B; its functions are the same as those of the <math>\overline{WE}</math> pin.</p> <p>EXTENSION 2FDD MODE: <math>\overline{WE2}</math></p> <p>This pin is for Extension FDD A and B; the function of this pin is the same as that of the <math>\overline{WE}</math> pin.</p>
$\overline{ERR}$	29	IN <sub>t</sub>   OD <sub>12</sub>  OD <sub>12</sub>	<p>PRINTER MODE: <math>\overline{ERR}</math></p> <p>An active low input on this pin indicates that the printer has encountered an error condition. This pin is pulled high internally. Refer to the description of the parallel port for the definition of this pin in ECP and EPP mode.</p> <p>EXTENSION FDD MODE: <math>\overline{HEAD2}</math></p> <p>This pin is for Extension FDD B; its function is the same as that of the <math>\overline{HEAD}</math> pin.</p> <p>EXTENSION 2FDD MODE: <math>\overline{HEAD2}</math></p> <p>This pin is for Extension FDD A and B; its function is the same as that of the <math>\overline{HEAD}</math> pin.</p>

**1.3 Multi-Mode Parallel Port, continued**

<b>SYMBOL</b>	<b>PIN</b>	<b>I/O</b>	<b>FUNCTION</b>
$\overline{\text{SLIN}}$	22	OD <sub>12</sub>  OD <sub>12</sub>  OD <sub>12</sub>	<p>PRINTER MODE: <math>\overline{\text{SLIN}}</math></p> <p>Output line for detection of printer selection. This pin is pulled high internally. Refer to the description of the parallel port for the definition of this pin in ECP and EPP mode.</p> <p>EXTENSION FDD MODE: <math>\overline{\text{STEP2}}</math></p> <p>This pin is for Extension FDD B; its function is the same as that of the <math>\overline{\text{STEP}}</math> pin.</p> <p>EXTENSION 2FDD MODE: <math>\overline{\text{STEP2}}</math></p> <p>This pin is for Extension FDD A and B; its function is the same as that of the <math>\overline{\text{STEP}}</math> pin .</p>
$\overline{\text{INIT}}$	21	OD <sub>12</sub>  OD <sub>12</sub>  OD <sub>12</sub>	<p>PRINTER MODE: <math>\overline{\text{INIT}}</math></p> <p>Output line for the printer initialization. This pin is pulled high internally. Refer to the description of the parallel port for the definition of this pin in ECP and EPP mode.</p> <p>EXTENSION FDD MODE: <math>\overline{\text{DIR2}}</math></p> <p>This pin is for Extension FDD B; its function is the same as that of the <math>\overline{\text{DIR}}</math> pin.</p> <p>EXTENSION 2FDD MODE: <math>\overline{\text{DIR2}}</math></p> <p>This pin is for Extension FDD A and B; its function is the same as that of the <math>\overline{\text{DIR}}</math> pin.</p>
$\overline{\text{AFD}}$	20	OD <sub>12</sub>  OD <sub>12</sub>  OD <sub>12</sub>	<p>PRINTER MODE: <math>\overline{\text{AFD}}</math></p> <p>An active low output from this pin causes the printer to auto feed a line after a line is printed. This pin is pulled high internally. Refer to the description of the parallel port for the definition of this pin in ECP and EPP mode.</p> <p>EXTENSION FDD MODE: <math>\overline{\text{RWC2}}</math></p> <p>This pin is for Extension FDD B; its function is the same as that of the <math>\overline{\text{RWC}}</math> pin.</p> <p>EXTENSION 2FDD MODE: <math>\overline{\text{RWC2}}</math></p> <p>This pin is for Extension FDD A and B; its function is the same as that of the <math>\overline{\text{RWC}}</math> pin.</p>

**1.3 Multi-Mode Parallel Port, continued**

<b>SYMBOL</b>	<b>PIN</b>	<b>I/O</b>	<b>FUNCTION</b>
$\overline{\text{STB}}$	19	$\text{OD}_{12}$	<p>PRINTER MODE: <math>\overline{\text{STB}}</math></p> <p>An active low output is used to latch the parallel data into the printer. This pin is pulled high internally. Refer to the description of the parallel port for the definition of this pin in ECP and EPP mode.</p> <p>- EXTENSION FDD MODE: No Connection This pin is a tri-state output.</p> <p>- EXTENSION 2FDD MODE: No Connection This pin is a tri-state output.</p>
PD0	9	$\text{I/O}_{24\text{t}}$  $\text{IN}_\text{t}$  $\text{IN}_\text{t}$	<p>PRINTER MODE: PD0</p> <p>Parallel port data bus bit 0. Refer to the description of the parallel port for the definition of this pin in ECP and EPP mode.</p> <p>EXTENSION FDD MODE: <math>\overline{\text{INDEX2}}</math></p> <p>This pin is for Extension FDD B; the function of this pin is the same as that of the <math>\overline{\text{INDEX}}</math> pin. This pin is pulled high internally.</p> <p>EXTENSION 2FDD MODE: <math>\overline{\text{INDEX2}}</math></p> <p>This pin is for Extension FDD A and B; the function of this pin is the same as <math>\overline{\text{INDEX}}</math> pin. This pin is pulled high internally.</p>
PD1	10	$\text{I/O}_{24\text{t}}$  $\text{IN}_\text{t}$  $\text{IN}_\text{t}$	<p>PRINTER MODE: PD1</p> <p>Parallel port data bus bit 1. Refer to the description of the parallel port for the definition of this pin in ECP and EPP mode.</p> <p>EXTENSION FDD MODE: <math>\overline{\text{TRAK02}}</math></p> <p>This pin is for Extension FDD B; the function of this pin is the same as that of the <math>\overline{\text{TRAK0}}</math> pin. This pin is pulled high internally.</p> <p>EXTENSION. 2FDD MODE: <math>\overline{\text{TRAK02}}</math></p> <p>This pin is for Extension FDD A and B; the function of this pin is the same as <math>\overline{\text{TRAK0}}</math> pin. This pin is pulled high internally.</p>

**1.3 Multi-Mode Parallel Port, continued**

<b>SYMBOL</b>	<b>PIN</b>	<b>I/O</b>	<b>FUNCTION</b>
PD2	11	I/O <sub>24t</sub>  IN <sub>t</sub>  IN <sub>t</sub>	<p>PRINTER MODE: PD2 Parallel port data bus bit 2. Refer to the description of the parallel port for the definition of this pin in ECP and EPP mode.</p> <p>EXTENSION FDD MODE: <math>\overline{WP2}</math> This pin is for Extension FDD B; the function of this pin is the same as that of the <math>\overline{WP}</math> pin. This pin is pulled high internally.</p> <p>EXTENSION 2FDD MODE: <math>\overline{WP2}</math> This pin is for Extension FDD A and B; the function of this pin is the same as that of the <math>\overline{WP}</math> pin. This pin is pulled high internally.</p>
PD3	12	I/O <sub>24t</sub>  IN <sub>t</sub>  IN <sub>t</sub>	<p>PRINTER MODE: PD3 Parallel port data bus bit 3. Refer to the description of the parallel port for the definition of this pin in ECP and EPP mode.</p> <p>EXTENSION FDD MODE: <math>\overline{RDATA2}</math> Motor on B for Extension FDD B; the function of this pin is the same as that of the <math>\overline{RDATA}</math> pin. This pin is pulled high internally.</p> <p>EXTENSION 2FDD MODE: <math>\overline{RDATA2}</math> This pin is for Extension FDD A and B; the function of this pin is the same as that of the <math>\overline{RDATA}</math> pin. This pin is pulled high internally.</p>
PD4	13	I/O <sub>24t</sub>  IN <sub>t</sub>  IN <sub>t</sub>	<p>PRINTER MODE: PD4 Parallel port data bus bit 4. Refer to the description of the parallel port for the definition of this pin in ECP and EPP mode.</p> <p>EXTENSION FDD MODE: <math>\overline{DSKCHG2}</math> Drive select B for Extension FDD B; the function of this pin is the same as that of <math>\overline{DSKCHG}</math> pin. This pin is pulled high internally.</p> <p>EXTENSION 2FDD MODE: <math>\overline{DSKCHG2}</math> This pin is for Extension FDD A and B; the function of this pin is the same as that of the <math>\overline{DSKCHG}</math> pin. This pin is pulled high internally.</p>
PD5	14	I/O <sub>24t</sub>  -  -	<p>PRINTER MODE: PD5 Parallel port data bus bit 5. Refer to the description of the parallel port for the definition of this pin in ECP and EPP mode.</p> <p>EXTENSION FDD MODE: No Connection This pin is a tri-state output.</p> <p>EXTENSION 2FDD MODE: No Connection This pin is a tri-state output.</p>

**1.3 Multi-Mode Parallel Port, continued**

SYMBOL	PIN	I/O	FUNCTION
PD6	16	I/O <sub>24t</sub>  - IOD <sub>24</sub>	<p>PRINTER MODE: PD6</p> <p>Parallel port data bus bit 6. Refer to the description of the parallel port for the definition of this pin in ECP and EPP mode.</p> <p>EXTENSION FDD MODE: This pin is a tri-state output.</p> <p>EXTENSION. 2FDD MODE: <math>\overline{MOA2}</math></p> <p>This pin is for Extension FDD A; its function is the same as that of the <math>\overline{MOA}</math> pin.</p>
PD7	17	I/O <sub>24t</sub>  - OD <sub>24</sub>	<p>PRINTER MODE: PD7</p> <p>Parallel port data bus bit 7. Refer to the description of the parallel port for the definition of this pin in ECP and EPP mode.</p> <p>EXTENSION FDD MODE: This pin is a tri-state output.</p> <p>EXTENSION 2FDD MODE: <math>\overline{DSA2}</math></p> <p>This pin is for Extension FDD A; its function is the same as that of the <math>\overline{DSA}</math> pin.</p>

**1.4 FDC Interface**

SYMBOL	PIN	I/O	FUNCTION
$\overline{RDATA}$	74	IN <sub>cs</sub>	The read data input signal from the FDD. This input pin is pulled up internally by an approximately 1K ohm resistor. The resistor can be disabled by bit 4 of CR6 (FIPURDWN).
$\overline{DSKCHG}$	76	IN <sub>cs</sub>	Diskette change. This signal is active low at power on and whenever the diskette is removed. This input pin is pulled up internally by an approximately 1K ohm resistor. The resistor can be disabled by bit 4 of CR6 (FIPURDWN).
$\overline{WP}$	77	IN <sub>cs</sub>	Write protected. This active low schmitt input from the disk drive indicates that the diskette is write-protected. This input pin is pulled up internally by an approximately 1K ohm resistor. The resistor can be disabled by bit 4 of CR6 (FIPURDWN).
$\overline{TRAK0}$	78	IN <sub>cs</sub>	Track 0. This schmitt input from the disk drive is active low when the head is positioned over the outermost track. This input pin is pulled up internally by an approximately 1K ohm resistor. The resistor can be disabled by bit 4 of CR6 (FIPURDWN).

**1.4 FDC interface, continued**

<b>SYMBOL</b>	<b>PIN</b>	<b>I/O</b>	<b>FUNCTION</b>
$\overline{\text{INDEX}}$	81	IN <sub>CS</sub>	This schmitt input from the disk drive is active low when the head is positioned over the beginning of a track marked by an index hole. This input pin is pulled up internally by an approximately 1K ohm resistor. The resistor can be disabled by bit 4 of CR6 (FIPURDWN).
$\overline{\text{MOA}}$	79	OD <sub>24</sub>	Motor A On. When set to 0, this pin enables disk drive 0. This is an open drain output.
$\overline{\text{MOB}}$	80	OD <sub>24</sub>	Motor B On. When set to 0, this pin enables disk drive 1. This is an open drain output.
$\overline{\text{STEP}}$	82	OD <sub>24</sub>	Step output pulses. This active low open drain output produces a pulse to move the head to another track.
$\overline{\text{DSA}}$	83	OD <sub>24</sub>	Drive Select A. When set to 0, this pin enables disk drive A. This is an open drain output.
$\overline{\text{DSB}}$	84	OD <sub>24</sub>	Drive Select B. When set to 0, this pin enables disk drive B. This is an open drain output.
$\overline{\text{WE}}$	85	OD <sub>24</sub>	Write enable. An open drain output.
$\overline{\text{WD}}$	86	OD <sub>24</sub>	Write data. This logic low open drain writes precompensation serial data to the selected FDD. An open drain output.
$\overline{\text{RWC}}$	87	OD <sub>24</sub>	Reduced write current. This signal can be used on two-speed disk drives to select the transfer rate. An open drain output. Logic 0 = 250 Kb/s Logic 1 = 500 Kb/s When bit 5 of CR9 (EN3MODE) is set to high, the three-mode FDD function is enabled, and the pin will have a different definition. Refer to the EN3MODE bit in CR9.
$\overline{\text{HEAD}}$	88	OD <sub>24</sub>	Head select. This open drain output determines which disk drive head is active. Logic 1 = side 0 Logic 0 = side 1
$\overline{\text{DIR}}$	89	OD <sub>24</sub>	Direction of the head step motor. An open drain output. Logic 1 = outward motion Logic 0 = inward motion
VDD	15, 56		+5 power supply for the digital circuitry
GND	25, 40, 65, 90		Ground

## 2.0 FDC FUNCTIONAL DESCRIPTION

### 2.1 W83877ATF FDC

The floppy disk controller of the W83877ATF integrates all of the logic required for floppy disk control. The FDC implements a PC/AT or PS/2 solution. All programmable options default to compatible values. The FIFO provides better system performance in multi-master systems. The digital data separator supports up to data rate 1 M bits/sec or 2 M bits/sec.

The FDC includes the following blocks: AT interface, Precompensation, Data Rate Selection, Digital Data Separator, FIFO, and FDC Core.

#### 2.1.1 AT interface

The interface consists of the standard asynchronous signals:  $\overline{RD}$ ,  $\overline{WR}$ , A0-A3, IRQ, DMA control, and a data bus. The address lines select between the configuration registers, the FIFO and control/status registers. This interface can be switched between PC/AT, Model 30, or PS/2 normal modes. The PS/2 register sets are a superset of the registers found in a PC/AT.

#### 2.1.2 FIFO (Data)

The FIFO is 16 bytes in size and has programmable threshold values. All command parameter information and disk data transfers go through the FIFO. Data transfers are governed by the RQM and DIO bits in the Main Status Register.

The FIFO defaults to disabled mode after any form of reset. This maintains PC/AT hardware compatibility. The default values can be changed through the CONFIGURE command. The advantage of the FIFO is that it allows the system a larger DMA latency without causing disk errors. The following tables give several examples of the delays with a FIFO. The data are based upon the following formula:

$$\text{THRESHOLD} \times (1/\text{Data Rate}) * 8 - 1.5 \mu\text{S} = \text{DELAY}$$

FIFO THRESHOLD	MAXIMUM DELAY TO SERVICING AT 500K BPS
	Data Rate
1 Byte	$1 \times 16 \mu\text{S} - 1.5 \mu\text{S} = 14.5 \mu\text{S}$
2 Byte	$2 \times 16 \mu\text{S} - 1.5 \mu\text{S} = 30.5 \mu\text{S}$
8 Byte	$8 \times 16 \mu\text{S} - 1.5 \mu\text{S} = 6.5 \mu\text{S}$
15 Byte	$15 \times 16 \mu\text{S} - 1.5 \mu\text{S} = 238.5 \mu\text{S}$
FIFO THRESHOLD	MAXIMUM DELAY TO SERVICING AT 1M BPS
	Data Rate
1 Byte	$1 \times 8 \mu\text{S} - 1.5 \mu\text{S} = 6.5 \mu\text{S}$
2 Byte	$2 \times 8 \mu\text{S} - 1.5 \mu\text{S} = 14.5 \mu\text{S}$
8 Byte	$8 \times 8 \mu\text{S} - 1.5 \mu\text{S} = 62.5 \mu\text{S}$
15 Byte	$15 \times 8 \mu\text{S} - 1.5 \mu\text{S} = 118.5 \mu\text{S}$

At the start of a command the FIFO is always disabled, and command parameters must be sent based upon the RQM and DIO bit settings in the main status register. When the FDC enters the command execution phase, it clears the FIFO of any data to ensure that invalid data are not transferred.

An overrun and underrun will terminate the current command and the data transfer. Disk writes will complete the current sector by generating a 00 pattern and valid CRC. Reads require the host to remove the remaining data so that the result phase may be entered.

DMA transfers are enabled with the SPECIFY command and are initiated by the FDC by activating the DRQ pin during a data transfer command. The FIFO is enabled directly by asserting  $\overline{\text{DACK}}$ , and addresses need not be valid.

Note that if the DMA controller is programmed to function in verify mode, a pseudo read is performed by the FDC based only on  $\overline{\text{DACK}}$ . This mode is only available when the FDC has been configured into byte mode (FIFO disabled) and is programmed to do a read. With the FIFO enabled the above operation is performed by using the new VERIFY command. No DMA operation is needed. <sup>j</sup>@

### 2.1.3 Data Separator

The function of the data separator is to lock onto the incoming serial read data. When a lock is achieved the serial front end logic of the chip is provided with a clock which is synchronized to the read data. The synchronized clock, called the Data Window, is used to internally sample the serial data portion of the bit cell, and the alternate state samples the clock portion. Serial to parallel conversion logic separates the read data into clock and data bytes.

The Digital Data Separator (DDS) has three parts: control logic, error adjustment, and speed tracking. The DDS circuit cycles once every 12 clock cycles ideally. Any data pulse input will be synchronized and then adjusted by immediate error adjustment. The control logic will generate RDD and RWD for every pulse input. During any cycle where no data pulse is present, the DDS cycles are based on speed. A digital integrator is used to keep track of the speed changes in the input data stream.

### 2.1.4 Write Precompensation

The write precompensation logic is used to minimize bit shifts in the RDDATA stream from the disk drive. Shifting of bits is a known phenomenon in magnetic media and is dependent on the disk media and the floppy drive.

The FDC monitors the bit stream that is being sent to the drive. The data patterns that require precompensation are well known. Depending upon the pattern, the bit is shifted either early or late relative to the surrounding bits.

### 2.1.5 Perpendicular Recording Mode

The FDC is also capable of interfacing directly to perpendicular recording floppy drives. Perpendicular recording differs from the traditional longitudinal method in that the magnetic bits are oriented vertically. This scheme packs more data bits into the same area.

FDCs with perpendicular recording drives can read standard 3.5" floppy disks, and can also read and write perpendicular media. Some manufacturers offer drives that can read and write standard and perpendicular media in a perpendicular media drive.

A single command puts the FDC into perpendicular mode. All other commands operate as they do normally. The perpendicular mode requires a 1 Mbps data rate for the FDC. At this data rate the FIFO eases the host interface bottleneck due to the speed of data transfer to or from the disk.

### 2.1.6 Tape Drive

The W83877ATF supports standard tape drives (1 Mbps, 500 Kbps, 250 Kbps) and new fast tape drive (2M bps).

### 2.1.7 FDC Core

The W83877ATF FDC is capable of performing twenty commands. Each command is initiated by a multi-byte transfer from the microprocessor. The result can also be a multi-byte transfer back to the microprocessor. Each command consists of three phases: command, execution, and result.

#### Command

The microprocessor issues all required information to the controller to perform a specific operation.

#### Execution

The controller performs the specified operation.

#### Result

After the operation is completed, status information and other housekeeping information is provided to the microprocessor.

### 2.1.8 FDC Commands

Command Symbol Descriptions:

C:	Cylinder number 0 - 256
D:	Data Pattern
DIR:	Step Direction DIR = 0, step out DIR = 1, step in
DS0:	Disk Drive Select 0
DS1:	Disk Drive Select 1
DTL:	Data Length
EC:	Enable Count
EOT:	End of Track
EFIFO:	Enable FIFO
EIS:	Enable Implied Seek
EOT:	End of track
FIFOTHR:	FIFO Threshold
GAP:	Gap length selection
GPL:	Gap Length
H:	Head number
HDS:	Head number select
HLT:	Head Load Time
HUT:	Head Unload Time
LOCK:	Lock EFIFO, FIFOTHR, PTRTRK bits prevent affected by software reset
MFM:	MFM or FM Mode
MT:	Multitrack
N:	The number of data bytes written in a sector
NCN:	New Cylinder Number
ND:	Non-DMA Mode

OW: Overwritten  
 PCN: Present Cylinder Number  
 POLL:      Polling Disable  
 PRETRK:      Precompensation Start Track Number  
 R: Record  
 RCN: Relative Cylinder Number  
 R/W: Read/Write  
 SC: Sector/per cylinder  
 SK: Skip deleted data address mark  
 SRT: Step Rate Time  
 ST0: Status Register 0  
 ST1: Status Register 1  
 ST2: Status Register 2  
 ST3: Status Register 3  
 WG: Write gate alters timing of WE

### 2.1.9 FDC Instruction Sets

#### (1) Read Data

PHASE	R/W	D7	D6	D5	D4	D3	D2	D1	D0	REMARKS		
Command	W	MT	MFM	SK	0	0	1	1	0	Command codes		
	W	0	0	0	0	0	HDS	DS1	DS0			
	W	-----				C	-----				Sector ID information prior to command execution	
	W	-----				H	-----					
	W	-----				R	-----					
	W	-----				N	-----					
	W	-----				EOT	-----					
	W	-----				GPL	-----					
W	-----				DTL	-----						
Execution										Data transfer between the FDD and system		
Result	R	-----				ST0	-----				Status information after command execution	
	R	-----				ST1	-----					
	R	-----				ST2	-----					
	R	-----				C	-----				Sector ID information after command execution	
	R	-----				H	-----					
	R	-----				R	-----					
	R	-----				N	-----					

**(2) Read Deleted Data**

PHASE	R/W	D7	D6	D5	D4	D3	D2	D1	D0	REMARKS	
Command	W	MT	MFM	SK	0	1	1	0	0	Command codes	
	W	0	0	0	0	0	HDS	DS1	DS0		
	W	----- C -----									Sector ID information prior to command execution
	W	----- H -----									
	W	----- R -----									
	W	----- N -----									
	W	----- EOT -----									
	W	----- GPL -----									
	W	----- DTL -----									
Execution										Data transfer between the FDD and system	
Result	R	----- ST0 -----								Status information after command execution	
	R	----- ST1 -----									
	R	----- ST2 -----									
	R	----- C -----								Sector ID information after command execution	
	R	----- H -----									
	R	----- R -----									
	R	----- N -----									

**(3) Read A Track**

PHASE	R/W	D7	D6	D5	D4	D3	D2	D1	D0	REMARKS	
Command	W	0	MFM	0	0	0	0	1	0	Command codes  Sector ID information prior to command execution	
	W	0	0	0	0	0	HDS	DS1	DS0		
	W	----- C -----									
	W	----- H -----									
	W	----- R -----									
	W	----- N -----									
	W	----- EOT -----									
	W	----- GPL -----									
W	----- DTL -----										
Execution										Data transfer between the FDD and system; FDD reads contents of all cylinders from index hole to EOT	
Result	R	----- ST0 -----									Status information after command execution  Sector ID information after command execution
	R	----- ST1 -----									
	R	----- ST2 -----									
	R	----- C -----									
	R	----- H -----									
	R	----- R -----									
	R	----- N -----									

**(4) Read ID**

PHASE	R/W	D7	D6	D5	D4	D3	D2	D1	D0	REMARKS
Command	W	0	MFM	0	0	1	0	1	0	Command codes
	W	0	0	0	0	0	HDS	DS1	DS0	
Execution										The first correct ID information on the cylinder is stored in Data Register
Result	R	----- ST0 -----								Status information after command execution
	R	----- ST1 -----								
	R	----- ST2 -----								
	R	----- C -----								Disk status after the command has been completed
	R	----- H -----								
	R	----- R -----								
	R	----- N -----								

**(5) Verify**

PHASE	R/W	D7	D6	D5	D4	D3	D2	D1	D0	REMARKS	
Command	W	MT	MFM	SK	1	0	1	1	0	Command codes	
	W	EC	0	0	0	0	HDS	DS1	DS0		
	W	----- C -----									Sector ID information prior to command execution
	W	----- H -----									
	W	----- R -----									
	W	----- N -----									
	W	----- EOT -----									
	W	----- GPL -----									
W	----- DTL/SC -----										
Execution										No data transfer takes place	
Result	R	----- ST0 -----								Status information after command execution	
	R	----- ST1 -----									
	R	----- ST2 -----									
	R	----- C -----								Sector ID information after command execution	
	R	----- H -----									
	R	----- R -----									
	R	----- N -----									

**(6) Version**

PHASE	R/W	D7	D6	D5	D4	D3	D2	D1	D0	REMARKS
Command	W	0	0	0	1	0	0	0	0	Command codes
Result	W	1	0	0	1	0	0	0	0	Enhanced controller

**(7) Write Data**

PHASE	R/W	D7	D6	D5	D4	D3	D2	D1	D0	REMARKS	
Command	W	MT	MFM	0	0	0	1	0	1	Command codes	
	W	0	0	0	0	0	HDS	DS1	DS0		
	W	----- C -----									Sector ID information prior to Command execution
	W	----- H -----									
	W	----- R -----									
	W	----- N -----									
	W	----- EOT -----									
	W	----- GPL -----									
W	----- DTL -----										
Execution										Data transfer between the FDD and system	
Result	R	----- ST0 -----								Status information after Command execution	
	R	----- ST1 -----									
	R	----- ST2 -----									
	R	----- C -----								Sector ID information after Command execution	
	R	----- H -----									
	R	----- R -----									
	R	----- N -----									

**(8) Write Deleted Data**

PHASE	R/W	D7	D6	D5	D4	D3	D2	D1	D0	REMARKS
Command	W	MT	MFM	0	0	1	0	0	1	Command codes  Sector ID information prior to command execution
	W	0	0	0	0	0	HDS	DS1	DS0	
	W	----- C -----								
	W	----- H -----								
	W	----- R -----								
	W	----- N -----								
	W	----- EOT -----								
	W	----- GPL -----								
	W	----- DTL -----								
Execution										Data transfer between the FDD and system
Result	R	----- ST0 -----								Status information after command execution  Sector ID information after command execution
	R	----- ST1 -----								
	R	----- ST2 -----								
	R	----- C -----								
	R	----- H -----								
	R	----- R -----								
	R	----- N -----								

**(9) Format A Track**

PHASE	R/W	D7	D6	D5	D4	D3	D2	D1	D0	REMARKS	
Command	W	0	MFM	0	0	1	1	0	1	Command codes	
	W	0	0	0	0	0	HDS	DS1	DS0		
	W	----- N -----									Bytes/Sector
	W	----- SC -----									Sectors/Cylinder
	W	----- GPL -----									Gap 3
	W	----- D -----								Filler Byte	
Execution for Each Sector Repeat:	W	----- C -----								Input Sector Parameters	
	W	----- H -----									
	W	----- R -----									
	W	----- N -----									
Result	R	----- ST0 -----								Status information after command execution	
	R	----- ST1 -----									
	R	----- ST2 -----									
	R	----- Undefined -----									
	R	----- Undefined -----									
	R	----- Undefined -----									
	R	----- Undefined -----									

**(10) Recalibrate**

PHASE	R/W	D7	D6	D5	D4	D3	D2	D1	D0	REMARKS
Command	W	0	0	0	0	0	1	1	1	Command codes
	W	0	0	0	0	0	0	DS1	DS0	
Execution										Head retracted to Track 0 Interrupt

**(11) Sense Interrupt Status**

PHASE	R/W	D7	D6	D5	D4	D3	D2	D1	D0	REMARKS
Command	W	0	0	0	0	1	0	0	0	Command codes
Result	R	----- ST0 -----								Status information at the end of each seek operation
	R	----- PCN -----								

**(12) Specify**

PHASE	R/W	D7	D6	D5	D4	D3	D2	D1	D0	REMARKS
Command	W	0	0	0	0	0	0	1	1	Command codes
	W	-----SRT-----				-----HUT-----				
	W	-----HLT-----								

**(13) Seek**

PHASE	R/W	D7	D6	D5	D4	D3	D2	D1	D0	REMARKS
Command	W	0	0	0	0	1	1	1	1	Command codes
	W	0	0	0	0	0	HDS	DS1	DS0	
	W	-----NCN-----								
Execution	R									Head positioned over proper cylinder on diskette

**(14) Configure**

PHASE	R/W	D7	D6	D5	D4	D3	D2	D1	D0	REMARKS
Command	W	0	0	0	1	0	0	1	1	Configure information
	W	0	0	0	0	0	0	0	0	
	W	0	EIS	EFIFO	POLL	-----FIFOTHR-----				
	W	-----PRETRK-----								
Execution										Internal registers written

**(15) Relative Seek**

PHASE	R/W	D7	D6	D5	D4	D3	D2	D1	D0	REMARKS
Command	W	1	DIR	0	0	1	1	1	1	Command codes
	W	0	0	0	0	0	HDS	DS1	DS0	
	W	-----RCN-----								

**(16) Dumpreg**

PHASE	R/W	D7	D6	D5	D4	D3	D2	D1	D0	REMARKS	
Command	W	0	0	0	0	1	1	1	0	Registers placed in FIFO	
Result	R	----- PCN-Drive 0-----									
	R	----- PCN-Drive 1-----									
	R	----- PCN-Drive 2-----									
	R	----- PCN-Drive 3-----									
	R	----- SRT -----   ----- HUT -----									
	R	----- HLT -----  ND									
	R	----- SC/EOT -----									
	R	LOCK	0	D3	D2	D1	D0	GAP	WG		
	R	0	EIS	EFIFO	POLL		---	FIFOTHR	----		
	R	-----PRETRK-----									

**(17) Perpendicular Mode**

PHASE	R/W	D7	D6	D5	D4	D3	D2	D1	D0	REMARKS
Command	W	0	0	0	1	0	0	1	0	Command code
	W	OW	0	D3	D2	D1	D0	GAP	WG	

**(18) Lock**

PHASE	R/W	D7	D6	D5	D4	D3	D2	D1	D0	REMARKS
Command	W	LOCK	0	0	1	0	1	0	0	Command code
Result	R	0	0	0	LOCK	0	0	0	0	

**(19) Sense Drive Status**

PHASE	R/W	D7	D6	D5	D4	D3	D2	D1	D0	REMARKS
Command	W	0	0	0	0	0	1	0	0	Command code
	W	0	0	0	0	0	HDS	DS1	DS0	
Result	R	----- ST3-----								Status information about disk drive

**(20) Invalid**

PHASE	R/W	D7	D6	D5	D4	D3	D2	D1	D0	REMARKS
Command	W	----- Invalid Codes -----								Invalid codes (no operation - FDC goes into standby state)
Result	R	----- ST0-----								ST0 = 80H

## 2.2 Register Descriptions

There are several status, data, and control registers in W83877ATF. These registers are defined below:

ADDRESS OFFSET	REGISTER	
	READ	WRITE
base address + 0	SA REGISTER	
base address + 1	SB REGISTER	
base address + 2		DO REGISTER
base address + 3	TD REGISTER	TD REGISTER
base address + 4	MS REGISTER	DR REGISTER
base address + 5	DT (FIFO) REGISTER	DT (FIFO) REGISTER
base address + 7	DI REGISTER	CC REGISTER

### 2.2.1 Status Register A (SA Register) (Read base address + 0)

This register is used to monitor several disk interface pins in PS/2 and Model 30 modes. In PS/2 mode, the bit definitions for this register are as follows:

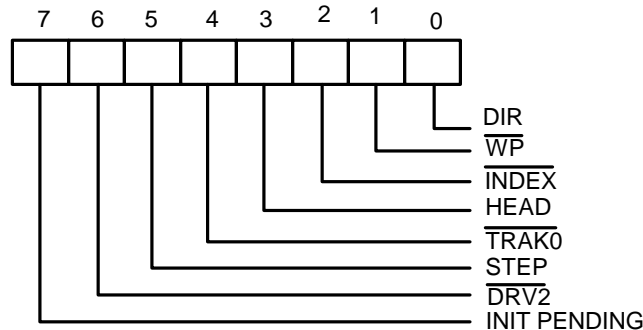

INIT PENDING (Bit 7):

This bit indicates the value of the floppy disk interrupt output.

$\overline{\text{DRV2}}$  (Bit 6):

0 A second drive has been installed

1 A second drive has not been installed

STEP (Bit 5):

This bit indicates the complement of  $\overline{\text{STEP}}$  output.

$\overline{\text{TRAK0}}$  (Bit 4):

This bit indicates the value of  $\overline{\text{TRAK0}}$  input.

HEAD (Bit 3):

This bit indicates the complement of  $\overline{\text{HEAD}}$  output.

0 side 0

1 side 1

$\overline{\text{INDEX}}$  (Bit 2):

This bit indicates the value of  $\overline{\text{INDEX}}$  output.

$\overline{\text{WP}}$  (Bit 1):

- 0 disk is write-protected
- 1 disk is not write-protected

DIR (Bit 0)

This bit indicates the direction of head movement.

- 0 outward direction
- 1 inward direction

In PS/2 Model 30 mode, the bit definitions for this register are as follows:

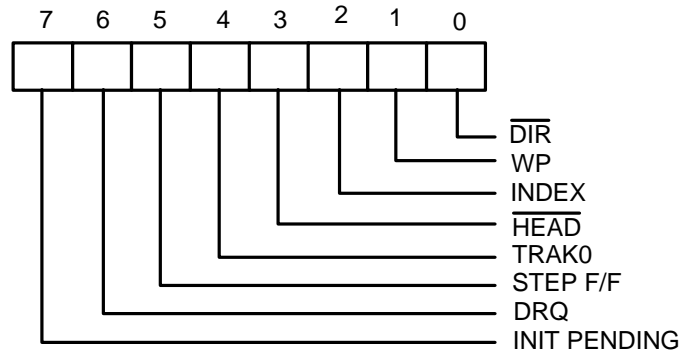

INIT PENDING (Bit 7):

This bit indicates the value of the floppy disk interrupt output.

DRQ (Bit 6):

This bit indicates the value of DRQ output pin.

STEP F/F (Bit 5):

This bit indicates the complement of latched  $\overline{\text{STEP}}$  output.

TRAK0 (Bit 4):

This bit indicates the complement of  $\overline{\text{TRAK0}}$  input.

$\overline{\text{HEAD}}$  (Bit 3):

This bit indicates the value of  $\overline{\text{HEAD}}$  output.

- 0 side 1
- 1 side 0

INDEX (Bit 2):

This bit indicates the complement of  $\overline{\text{INDEX}}$  output.

WP (Bit 1):

- 0 disk is not write-protected
- 1 disk is write-protected

$\overline{\text{DIR}}$  (Bit 0)

This bit indicates the direction of head movement.

- 0 inward direction
- 1 outward direction

**2.2.2 Status Register B (SB Register) (Read base address + 1)**

This register is used to monitor several disk interface pins in PS/2 and Model 30 modes. In PS/2 mode, the bit definitions for this register are as follows:

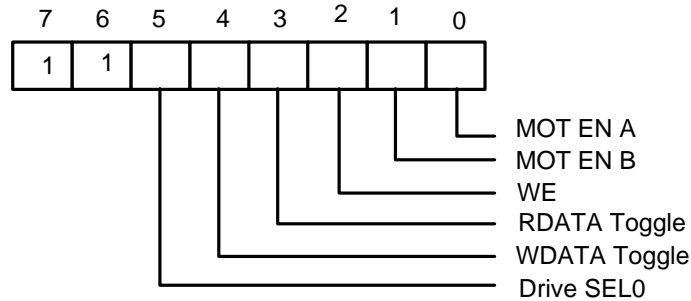

Drive SEL0 (Bit 5):

This bit indicates the status of DO REGISTER bit 0 (drive select bit 0).

WDATA Toggle (Bit 4):

This bit changes state at every rising edge of the  $\overline{\text{WD}}$  output pin.

RDATA Toggle (Bit 3):

This bit changes state at every rising edge of the  $\overline{\text{RDATA}}$  output pin.

WE (Bit 2):

This bit indicates the complement of the  $\overline{\text{WE}}$  output pin.

MOT EN B (Bit 1)

This bit indicates the complement of the  $\overline{\text{MOB}}$  output pin.

MOT EN A (Bit 0)

This bit indicates the complement of the  $\overline{\text{MOA}}$  output pin.

In PS/2 Model 30 mode, the bit definitions for this register are as follows:

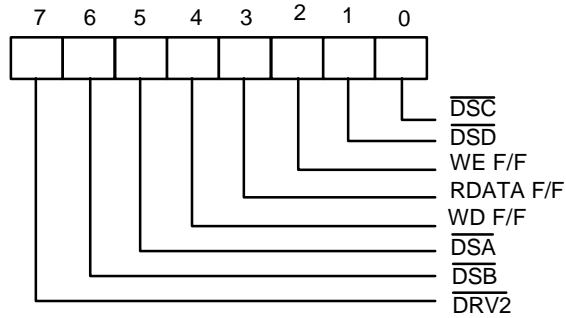

**$\overline{DRV2}$  (Bit 7):**

- 0 A second drive has been installed
- 1 A second drive has not been installed

**$\overline{DSB}$  (Bit 6):**

This bit indicates the status of  $\overline{DSB}$  output pin.

**$\overline{DSA}$  (Bit 5):**

This bit indicates the status of  $\overline{DSA}$  output pin.

**WD F/F (Bit 4):**

This bit indicates the complement of the latched  $\overline{WD}$  output pin at every rising edge of the  $\overline{WD}$  output pin.

**RDATA F/F (Bit 3):**

This bit indicates the complement of the latched  $\overline{RDATA}$  output pin .

**WE F/F (Bit 2):**

This bit indicates the complement of latched  $\overline{WE}$  output pin.

**$\overline{DSD}$  (Bit 1):**

- 0 Drive D has been selected
- 1 Drive D has not been selected

**$\overline{DSC}$  (Bit 0):**

- 0 Drive C has been selected
- 1 Drive C has not been selected

**2.2.3 Digital Output Register (DO Register) (Write base address + 2)**

The Digital Output Register is a write-only register controlling drive motors, drive selection, DRQ/IRQ enable, and FDC resetting. All the bits in this register are cleared by the MR pin. The bit definitions are as follows:

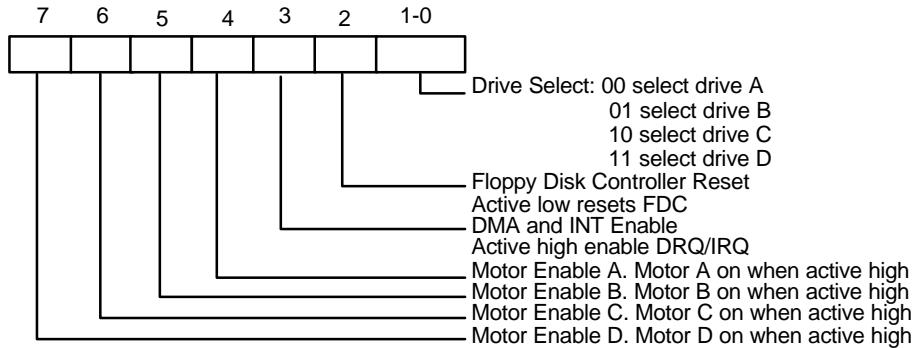

**2.2.4 Tape Drive Register (TD Register) (Read base address + 3)**

This register is used to assign a particular drive number to the tape drive support mode of the data separator. This register also holds the media ID, drive type, and floppy boot drive information of the floppy disk drive. In normal floppy mode, this register includes only bit 0 and 1. The bit definitions are as follows:

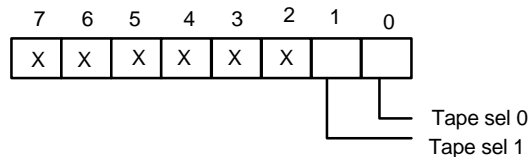

If three mode FDD function is enabled (EN3MODE = 1 in CR9), the bit definitions are as follows:

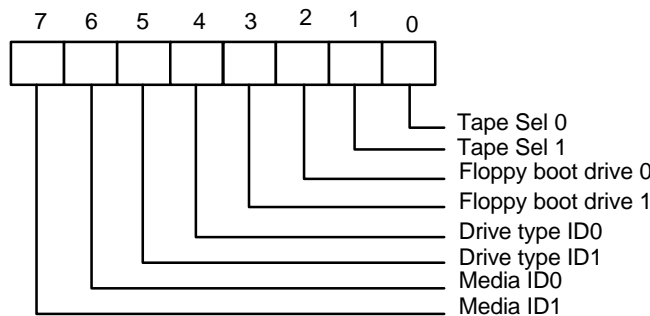

Media ID1 Media ID0 (Bit 7, 6):

These two bits are read only. These two bits reflect the value of CR8 bit 3, 2.

Drive type ID1 Drive type ID0 (Bit 5, 4):

These two bits reflect two of the bits of CR7. Which two bits are reflected depends on the last drive selected in the DO REGISTER.

Floppy Boot drive 1, 0 (Bit 3, 2):

These two bits reflect the value of CR8 bit 1, 0.

Tape Sel 1, Tape Sel 0 (Bit 1, 0):

These two bits assign a logical drive number to the tape drive. Drive 0 is not available as a tape drive, and is reserved as the floppy disk boot drive.

TAPE SEL 1	TAPE SEL 0	DRIVE SELECTED
0	0	None
0	1	1
1	0	2
1	1	3

**2.2.5 Main Status Register (MS Register) (Read base address + 4)**

The Main Status Register is used to control the flow of data between the microprocessor and the controller. The bit definitions for this register are as follows:

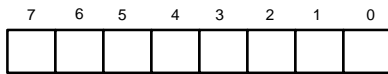

- 7 FDD 0 Busy, (D0B = 1), FDD number 0 is in the SEEK mode.
  - 6 FDD 1 Busy, (D1B = 1), FDD number 1 is in the SEEK mode.
  - 5 FDD 2 Busy, (D2B = 1), FDD number 2 is in the SEEK mode.
  - 4 FDD 3 Busy, (D3B = 1), FDD number 3 is in the SEEK mode.
  - 3 FDC Busy, (CB). A read or write command is in the process when CB = HIGH.
  - 2 Non-DMA mode, the FDC is in the non-DMA mode, this bit is set only during the execution phase in non-DMA mode.
  - 1 Transition to LOW state indicates execution phase has ended.
  - 0 DATA INPUT/OUTPUT, (DIO). If DIO= HIGH then transfer is from Data Register to the processor. If DIO = LOW then transfer is from processor to Data Register.
- Request for Master (RQM). A high on this bit indicates Data Register is ready to send or receive data to or from the processor.

**2.2.6 Data Rate Register (DR Register) (Write base address + 4)**

The Data Rate Register is used to set the transfer rate and write precompensation. The data rate of the FDC is programmed by the CC REGISTER for PC-AT and PS/2 Model 30 and PS/2 mode, and not by the DR REGISTER. The real data rate is determined by the most recent write to either of the DR REGISTER or CC REGISTER.

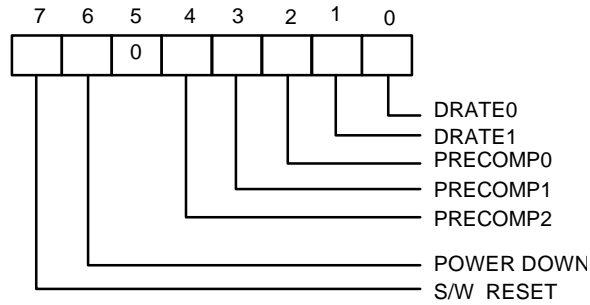
**S/W RESET (Bit 7):**

This bit is the software reset bit.

**POWER-DOWN (Bit 6):**

- 0 FDC in normal mode
- 1 FDC in power-down mode

**PRECOMP2 PRECOMP1 PRECOMP0 (Bit 4, 3, 2):**

These three bits select the value of write precompensation. The following tables show the precompensation values for the combination of these bits.

<b>PRECOM</b> 2 1 0	<b>PRECOMPENSATION DELAY</b>	
	250K - 1Mbps	2 Mbps Tape drive
0 0 0	Default Delays	Default Delays
0 0 1	41.67 nS	20.8nS
0 1 0	83.34 nS	41.17nS
0 1 1	125.00 nS	62.5nS
1 0 0	166.67 nS	83.3nS
1 0 1	208.33 nS	104.2nS
1 1 0	250.00 nS	125.00nS
1 1 1	0.00 nS (disabled)	0.00nS (disabled)

<b>DATA RATE</b>	<b>DEFAULT PRECOMPENSATION DELAYS</b>
250 KB/S	125 nS
300 KB/S	125 nS
500 KB/S	125 nS
1 MB/S	41.67 nS
2 MB/S	20.8 nS

DRATE1 DRATE0 (Bit 1, 0):

These two bits select the data rate of the FDC and reduced write current control.

- 00 500 KB/S (MFM), 250 KB/S (FM),  $\overline{RWC} = 1$ .
- 01 300 KB/S (MFM), 150 KB/S (FM),  $\overline{RWC} = 0$ .
- 10 250 KB/S (MFM), 125 KB/S (FM),  $\overline{RWC} = 0$ .
- 11 1 MB/S (MFM), Illegal (FM),  $\overline{RWC} = 1$ .

The 2MB/S data rate for Tape drive is only supported by setting 01 to DRATE1 and DRATE0 bits, as well as setting 10 to DRTA1 and DRTA0 bits, which are two of the Configuration CR2D. Please refer to the function of CR2D and the data rate table for individual data rates setting.

### 2.2.7 FIFO Register (R/W base address + 5)

The Data Register consists of four status registers in a stack, with only one register presented to the data bus at a time. This register stores data, commands, and parameters, and provides diskette-drive status information. Data bytes are passed through the data register to program or obtain results after a command. In the W83877ATF, this register defaults to FIFO disabled mode after reset. The FIFO can change its value and enable its operation through the CONFIGURE command.

#### Status Register 0 (ST0)

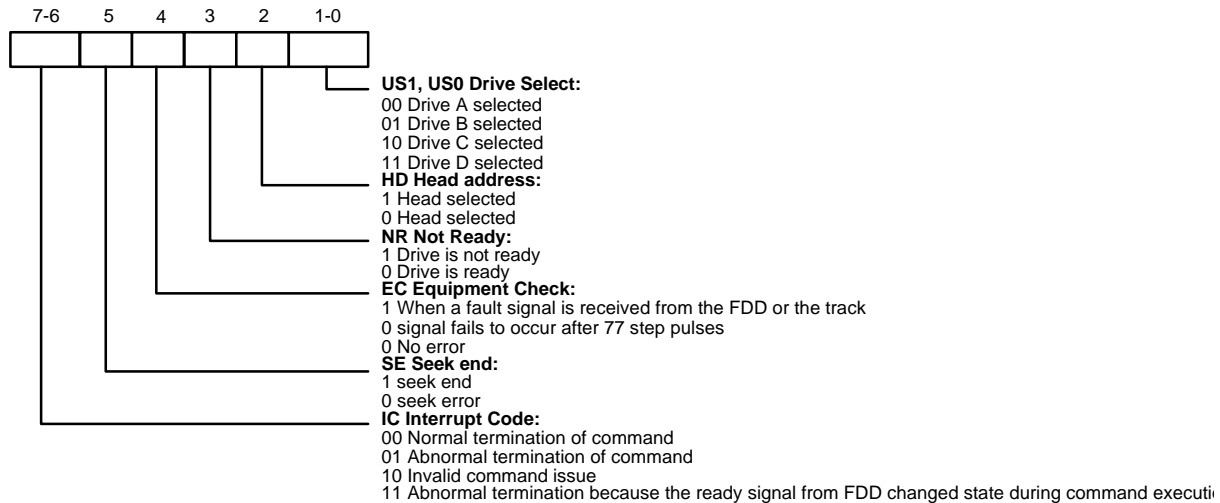

**Status Register 1 (ST1)**

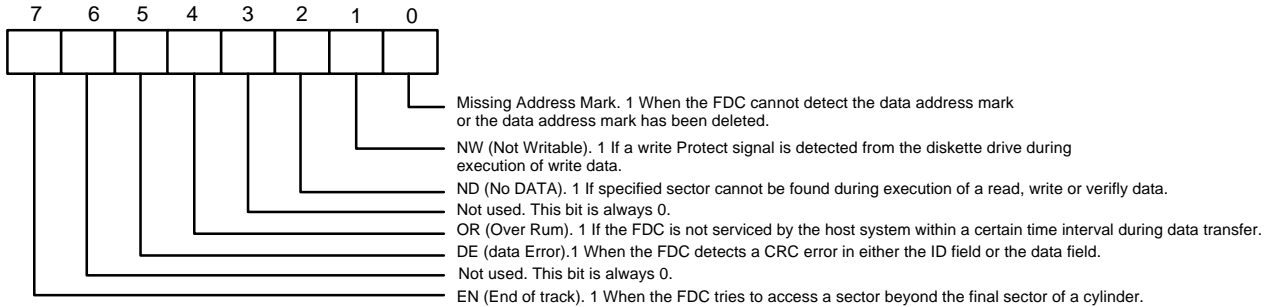

**Status Register 2 (ST2)**

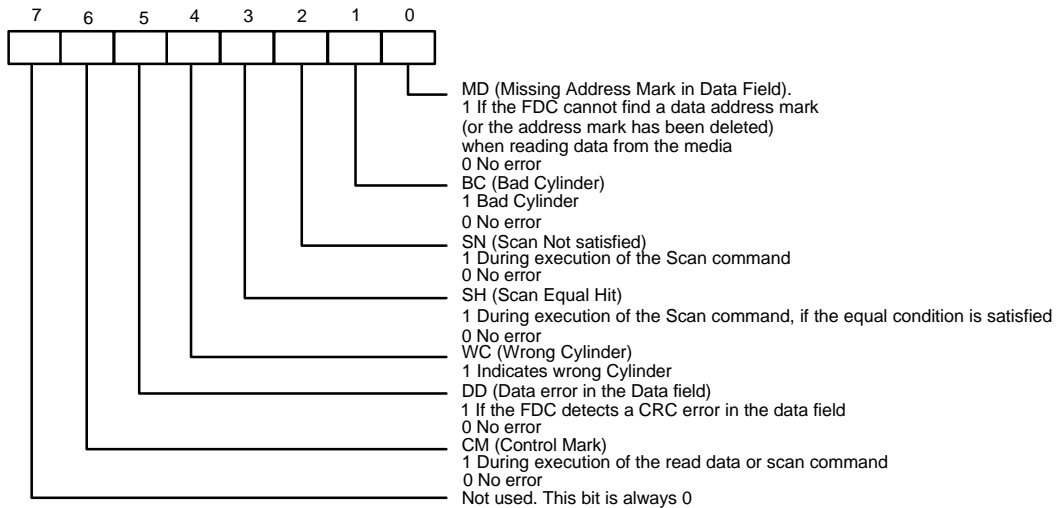

**Status Register 3 (ST3)**

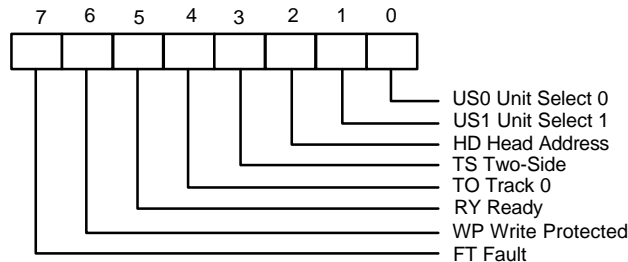

**2.2.8 Digital Input Register (DI Register) (Read base address + 7)**

The Digital Input Register is an 8-bit read-only register used for diagnostic purposes. In a PC/XT or AT only Bit 7 is checked by the BIOS. When the register is read, Bit 7 shows the complement of  $\overline{DSKCHG}$ , while other bits of the data bus remain in tri-state. Bit definitions are as follows:

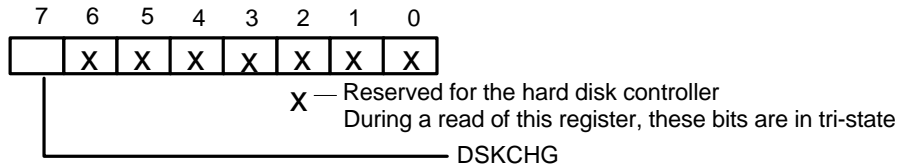

In the PS/2 mode, the bit definitions are as follows:

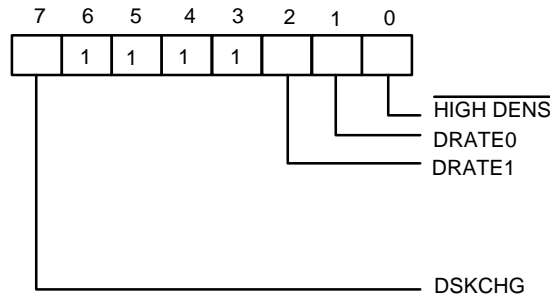

DSKCHG (Bit 7):

This bit indicates the complement of the  $\overline{DSKCHG}$  input.

Bit 6-3: These bits are always a logic 1 during a read.

DRATE1 DRATE0 (Bit 2, 1):

These two bits select the data rate of the FDC. Refer to the DR register bits 1 and 0 for the settings corresponding to the individual data rates.

$\overline{HIGH DENS}$  (Bit 0):

0 500 KB/S or 1 MB/S data rate (high density FDD)

1 250 KB/S or 300 KB/S data rate

In the PS/2 Model 30 mode, the bit definitions are as follows:

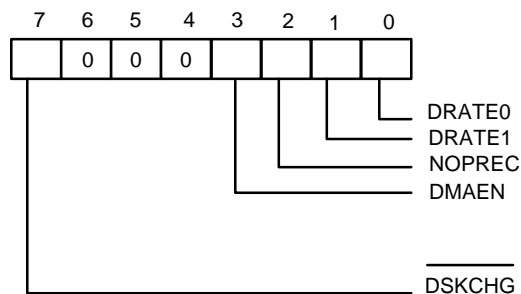

DSKCHG (Bit 7):

This bit indicates the status of  $\overline{\text{DSKCHG}}$  input.

Bit 6-4: These bits are always a logic 1 during a read.

DMAEN (Bit 3):

This bit indicates the value of DO REGISTER bit 3.

NOPREC (Bit 2):

This bit indicates the value of CC REGISTER NOPREC bit.

DRATE1 DRATE0 (Bit 1, 0):

These two bits select the data rate of the FDC.

### 2.2.9 Configuration Control Register (CC Register) (Write base address + 7)

This register is used to control the data rate. In the PC/AT and PS/2 mode, the bit definitions are as follows:

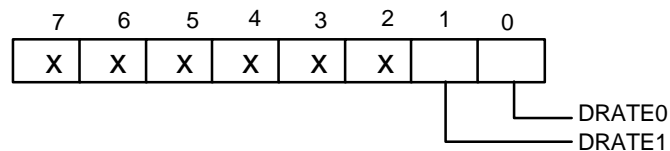

X: Reserved

Bit 7-2: Reserved. These bits should be set to 0.

DRATE1 DRATE0 (Bit 1, 0):

These two bits select the data rate of the FDC.

In the PS/2 Model 30 mode, the bit definitions are as follows:

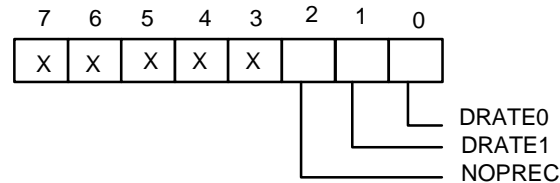

X: Reserved

Bit 7-3: Reserved. These bits should be set to 0.

NOPREC (Bit 2):

This bit indicates no precompensation. It has no function and can be set by software.

DRATE1 DRATE0 (Bit 1, 0):

These two bits select the data rate of the FDC.

### **3.0 UART PORT**

#### **3.1 Universal Asynchronous Receiver/Transmitter (UART A, UART B)**

The UARTs are used to convert parallel data into serial format on the transmit side, and convert serial data to parallel format on the receiver side. The serial format, in order of transmission and reception, is a start bit, followed by five to eight data bits, a parity bit (if programmed) and one, one and a half (five-bit format only) or two stop bits. The UARTs are capable of handling divisors of 1 to 65535 and producing a 16x clock for driving the internal transmitter logic. Provisions are also included to use this 16x clock to drive the receiver logic. The UARTs also support the MIDI data rate. Furthermore, the UARTs also include complete modem control capability, and a processor interrupt system that may be software trailed to the computing time required to handle the communication link. The UARTs have a FIFO mode to reduce the number of interrupts presented to the CPU. In each UART, there are 16-byte FIFOs for both receive and transmit mode.

### 3.2 Register Address

**TABLE 3-1 UART Register Bit Map**

Register Address Base		Bit Number								
		0	1	2	3	4	5	6	7	
8 BDLAB = 0	Receiver Buffer Register (Read Only)	RBR	RX Data Bit 0	RX Data Bit 1	RX Data Bit 2	RX Data Bit 3	RX Data Bit 4	RX Data Bit 5	RX Data Bit 6	RX Data Bit 7
8 BDLAB = 0	Transmitter Buffer Register (Write Only)	TBR	TX Data Bit 0	TX Data Bit 1	TX Data Bit 2	TX Data Bit 3	TX Data Bit 4	TX Data Bit 5	TX Data Bit 6	TX Data Bit 7
9 BDLAB = 0	Interrupt Control Register	ICR	RBR Data Ready Interrupt Enable (ERDRI)	TBR Empty Interrupt Enable (ETBREI)	USR Interrupt Enable (EUSRI)	HSR Interrupt Enable (EHSRI)	0	0	0	0
A	Interrupt Status Register (Read Only)	ISR	"0" if Interrupt Pending	Interrupt Status Bit (0)	Interrupt Status Bit (1)	Interrupt Status Bit (2)**	0	0	FIFOs Enabled **	FIFOs Enabled **
A	UART FIFO Control Register (Write Only)	UFR	FIFO Enable	RCVR FIFO Reset	XMIT FIFO Reset	DMA Mode Select	Reserved	Reversed	RX Interrupt Active Level (LSB)	RX Interrupt Active Level (MSB)
B	UART Control Register	UCR	Data Length Select Bit 0 (DLS0)	Data Length Select Bit 1 (DLS1)	Multiple Stop Bits Enable (MSBE)	Parity Bit Enable (PBE)	Even Parity Enable (EPE)	Parity Bit Fixed Enable (PBE)	Set Silence Enable (SSE)	Baud rate Divisor Latch Access Bit (BDLAB)
C	Handshake Control Register	HCR	Data Terminal Ready (DTR)	Request to Send (RTS)	Loopback RI Input	IRQ Enable	Internal Loopback Enable	0	0	0
D	UART Status Register	USR	RBR Data Ready (RDR)	Overrun Error (OER)	Parity Bit Error (PBER)	No Stop Bit Error (NSER)	Silent Byte Detected (SBD)	TBR Empty (TBRE)	TSR Empty (TSRE)	RX FIFO Error Indication (RFEI) **
E	Handshake Status Register	HSR	CTS Toggling (TCTS)	DSR Toggling (TDSR)	RI Falling Edge (FERI)	DCD Toggling (TDCD)	Clear to Send (CTS)	Data Set Ready (DSR)	Ring Indicator (RI)	Data Carrier Detect (DCD)
F	User Defined Register	UDR	Bit 0	Bit 1	Bit 2	Bit 3	Bit 4	Bit 5	Bit 6	Bit 7
8 BDLAB = 1	Baudrate Divisor Latch Low	BLL	Bit 0	Bit 1	Bit 2	Bit 3	Bit 4	Bit 5	Bit 6	Bit 7
9 BDLAB = 1	Baudrate Divisor Latch High	BHL	Bit 8	Bit 9	Bit 10	Bit 11	Bit 12	Bit 13	Bit 14	Bit 15

\*: Bit 0 is the least significant bit. The least significant bit is the first bit serially transmitted or received.

\*\* : These bits are always 0 in 16450 mode.

### 3.2.1 UART Control Register (UCR) (Read/Write)

The UART Control Register controls and defines the protocol for asynchronous data communications, including data length, stop bit, parity, and baud rate selection.

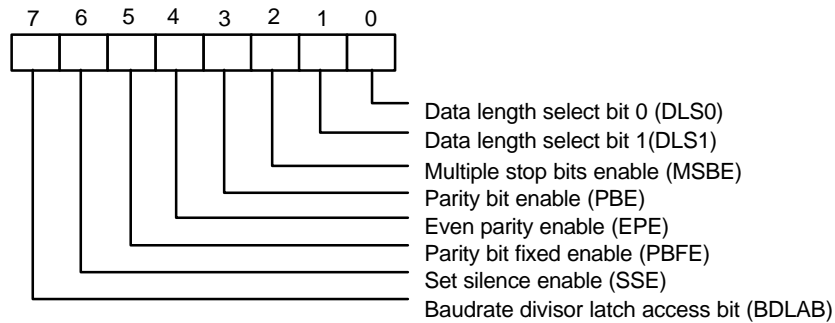

**Bit 7: BDLAB.** When this bit is set to a logical 1, designers can access the divisor (in 16-bit binary format) from the divisor latches of the baud rate generator during a read or write operation. When this bit is reset, the Receiver Buffer Register, the Transmitter Buffer Register, or the Interrupt Control Register can be accessed.

**Bit 6: SSE.** A logical 1 forces the Serial Output (SOUT) to a silent state (a logical 0). Only SOUT is affected by this bit; the transmitter is not affected.

**Bit 5: PBF.** When PBE and PBF of UCR are both set to a logical 1,

- (1) if EPE is a logical 1, the parity bit is fixed as a logical 0 to transmit and check.
- (2) if EPE is a logical 0, the parity bit is fixed as a logical 1 to transmit and check.

**Bit 4: EPE.** This bit describes the number of logic 1's in the data word bits and parity bit only when bit 3 is programmed. When this bit is set, an even number of logic 1's are sent or checked. When the bit is reset, an odd number of logic 1's are sent or checked.

**Bit 3: PBE.** When this bit is set, the position between the last data bit and the stop bit of the SOUT will be stuffed with the parity bit at the transmitter. For the receiver, the parity bit in the same position as the transmitter will be detected.

**Bit 2: MSBE.** This bit defines the number of stop bits in each serial character that is transmitted or received.

- (1) If MSBE is set to a logical 0, one stop bit is sent and checked.
- (2) If MSBE is set to a logical 1, and data length is 5 bits, one and a half stop bits are sent and checked.
- (3) If MSBE is set to a logical 1, and data length is 6, 7, or 8 bits, two stop bits are sent and checked.

**Bits 0 and 1: DLS0, DLS1.** These two bits define the number of data bits that are sent or checked in each serial character.

**TABLE 3-2 WORD LENGTH DEFINITION**

DLS1	DLS0	DATA LENGTH
0	0	5 bits
0	1	6 bits
1	0	7 bits
1	1	8 bits

**3.2.2 UART Status Register (USR) (Read/Write)**

This 8-bit register provides information about the status of the data transfer during communication.

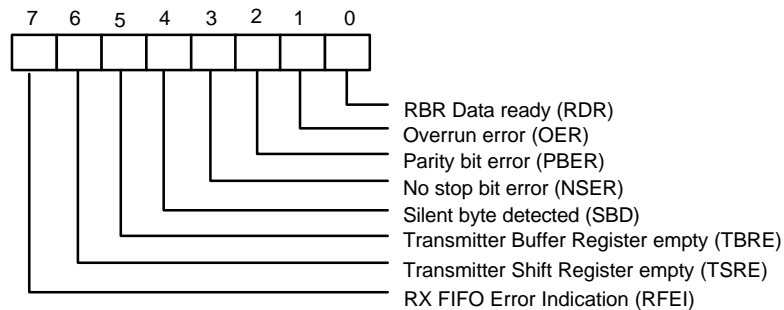

**Bit 7: RFEI.** In 16450 mode, this bit is always set to a logic 0. In 16550 mode, this bit is set to a logic 1 when there is at least one parity bit error, but no stop bit error or silent byte detected in the FIFO. In 16550 mode, this bit is cleared by reading from the USR if there are no remaining errors left in the FIFO.

**Bit 6: TSRE.** In 16450 mode, when TBR and TSR are both empty, this bit will be set to a logical 1. In 16550 mode, if the transmit FIFO and TSR are both empty, it will be set to a logical 1. Other than in these two cases, this bit will be reset to a logical 0.

**Bit 5: TBRE.** In 16450 mode, when a data character is transferred from TBR to TSR, this bit will be set to a logical 1. If ETREI of ICR is a logical 1, an interrupt will be generated to notify the CPU to write the next data. In 16550 mode, this bit will be set to a logical 1 when the transmit FIFO is empty. It will be reset to a logical 0 when the CPU writes data into TBR or FIFO.

**Bit 4: SBD.** This bit is set to a logical 1 to indicate that received data are kept in silent state for a full word time, including start bit, data bits, parity bit, and stop bits. In 16550 mode, it indicates the same condition for the data on top of the FIFO. When the CPU reads USR, it will clear this bit to a logical 0.

- Bit 3: NSER. This bit is set to a logical 1 to indicate that the received data have no stop bit. In 16550 mode, it indicates the same condition for the data on top of the FIFO. When the CPU reads USR, it will clear this bit to a logical 0.
- Bit 2: PBER. This bit is set to a logical 1 to indicate that the parity bit of the received data is wrong. In 16550 mode, it indicates the same condition for the data on top of the FIFO. When the CPU reads USR, it will clear this bit to a logical 0.
- Bit 1: OER. This bit is set to a logical 1 to indicate that received data have been overwritten by the next received data before they were read by the CPU. In 16550 mode, it indicates the same condition instead of FIFO full. When the CPU reads USR, it will clear this bit to a logical 0.
- Bit 0: RDR. This bit is set to a logical 1 to indicate received data are ready to be read by the CPU in the RBR or FIFO. After no data are left in the RBR or FIFO, the bit will be reset to a logical 0.

**3.2.3 Handshake Control Register (HCR) (Read/Write)**

This register controls the pins of the UART used for handshaking peripherals such as modem, and controls the diagnostic mode of the UART.

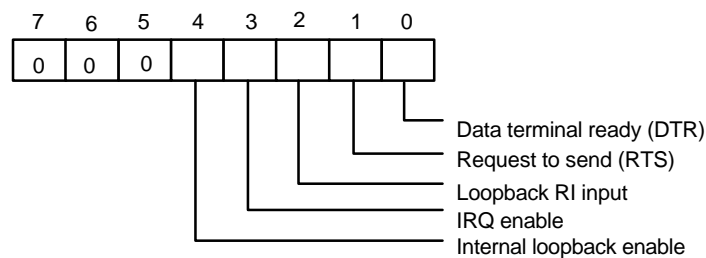

- Bit 4: When this bit is set to a logical 1, the UART enters diagnostic mode by an internal loopback, as follows:
  - (1) SOUT is forced to a logical 1, and SIN is isolated from the communication link instead of the TSR.
  - (2) Modem output pins are set to their inactive state.
  - (3) Modem input pins are isolated from the communication link and connect internally as DTR (bit 0 of HCR) →  $\overline{DSR}$ , RTS (bit 1 of HCR) →  $\overline{CTS}$ , Loopback RI input (bit 2 of HCR) →  $\overline{RI}$  and IRQ enable (bit 3 of HCR) →  $\overline{DCD}$ .

Aside from the above connections, the UART operates normally. This method allows the CPU to test the UART in a convenient way.
- Bit 3: The UART interrupt output is enabled by setting this bit to a logic 1. In the diagnostic mode this bit is internally connected to the modem control input  $\overline{DCD}$ .
- Bit 2: This bit is used only in the diagnostic mode. In the diagnostic mode this bit is internally connected to the modem control input  $\overline{RI}$ .
- Bit 1: This bit controls the  $\overline{RTS}$  output. The value of this bit is inverted and output to  $\overline{RTS}$ .
- Bit 0: This bit controls the  $\overline{DTR}$  output. The value of this bit is inverted and output to  $\overline{DTR}$ .

### 3.2.4 Handshake Status Register (HSR) (Read/Write)

This register reflects the current state of four input pins for handshake peripherals such as a modem, and records changes on these pins.

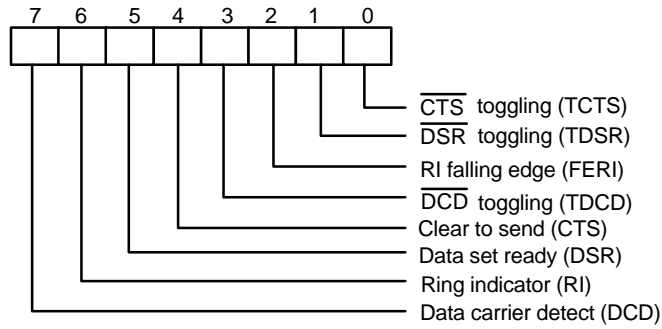

Bit 7: This bit is the opposite of the  $\overline{\text{DCD}}$  input. This bit is equivalent to bit 3 of HCR in loopback mode.

Bit 6: This bit is the opposite of the  $\overline{\text{RI}}$  input. This bit is equivalent to bit 2 of HCR in loopback mode.

Bit 5: This bit is the opposite of the  $\overline{\text{DSR}}$  input. This bit is equivalent to bit 0 of HCR in loopback mode.

Bit 4: This bit is the opposite of the  $\overline{\text{CTS}}$  input. This bit is equivalent to bit 1 of HCR in loopback mode.

Bit 3: TDCD. This bit indicates that the  $\overline{\text{DCD}}$  pin has changed state after HSR was read by the CPU.

Bit 2: FERI. This bit indicates that the  $\overline{\text{RI}}$  pin has changed from low to high state after HSR was read by the CPU.

Bit 1: TDSR. This bit indicates that the  $\overline{\text{DSR}}$  pin has changed state after HSR was read by the CPU.

Bit 0: TCTS. This bit indicates that the  $\overline{\text{CTS}}$  pin has changed state after HSR was read by the CPU.

### 3.2.5 UART FIFO Control Register (UFR) (Write only)

This register is used to control the FIFO functions of the UART.

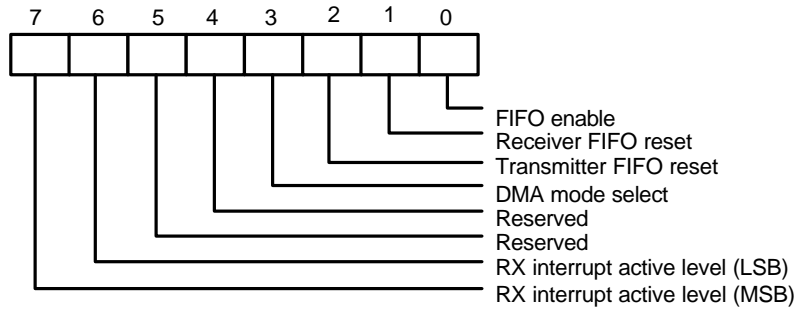

Bit 6, 7: These two bits are used to set the active level for the receiver FIFO interrupt. For example, if the interrupt active level is set as 4 bytes, once there are more than 4 data characters in the receiver FIFO, the interrupt will be activated to notify the CPU to read the data from the FIFO.

TABLE 3-3 FIFO TRIGGER LEVEL

BIT 7	BIT 6	RX FIFO INTERRUPT ACTIVE LEVEL (BYTES)
0	0	01
0	1	04
1	0	08
1	1	14

Bit 4, 5: Reserved

Bit 3: When this bit is programmed to logic 1, the DMA mode will change from mode 0 to mode 1 if UFR bit 0 = 1.

Bit 2: Setting this bit to a logical 1 resets the TX FIFO counter logic to initial state. This bit will clear to a logical 0 by itself after being set to a logical 1.

Bit 1: Setting this bit to a logical 1 resets the RX FIFO counter logic to initial state. This bit will clear to a logical 0 by itself after being set to a logical 1.

Bit 0: This bit enables the 16550 (FIFO) mode of the UART. This bit should be set to a logical 1 before other bits of UFR are programmed.

### 3.2.6 Interrupt Status Register (ISR) (Read only)

This register reflects the UART interrupt status, which is encoded by different interrupt sources into 3 bits.

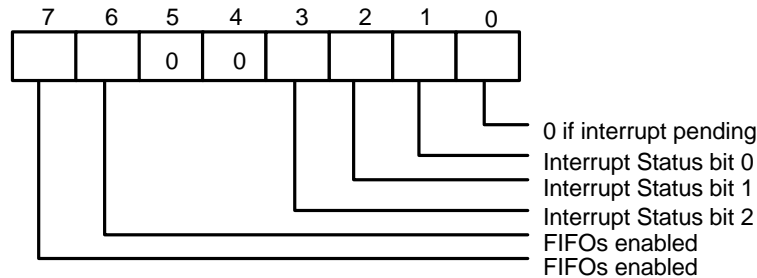

Bit 7, 6: These two bits are set to a logical 1 when UFR bit 0 = 1.

Bit 5, 4: These two bits are always logic 0.

Bit 3: In 16450 mode, this bit is 0. In 16550 mode, both bit 3 and 2 are set to a logical 1 when a -time-out interrupt is pending.

Bit 2, 1: These two bits identify the priority level of the pending interrupt, as shown in the table below.

Bit 0: This bit is a logical 1 if there is no interrupt pending. If one of the interrupt sources has occurred, this bit will be set to a logical 0.

TABLE 3-4 INTERRUPT CONTROL FUNCTION

ISR				INTERRUPT SET AND FUNCTION			
Bit 3	Bit 2	Bit 1	Bit 0	Interrupt priority	Interrupt Type	Interrupt Source	Clear Interrupt
0	0	0	1	-	-	No Interrupt pending	-
0	1	1	0	First	UART Receive Status	1. OER = 1 2. PBER = 1 3. NSER = 1 4. SBD = 1	Read USR
0	1	0	0	Second	RBR Data Ready	1. RBR data ready 2. FIFO interrupt active level reached	1. Read RBR 2. Read RBR until FIFO data under active level
1	1	0	0	Second	FIFO Data Timeout	Data present in RX FIFO for 4 characters period of time since last access of RX FIFO.	Read RBR
0	0	1	0	Third	TBR Empty	TBR empty	1. Write data into TBR 2. Read ISR (if priority is third)
0	0	0	0	Fourth	Handshake status	1. TCTS = 1 2. TDSR = 1 3. FER1 = 1 4. TDCD = 1	Read HSR

\*\* Bit 3 of ISR is enabled when bit 0 of UFR is logical 1.

**3.2.7 Interrupt Control Register (ICR) (Read/Write)**

This 8-bit register allows the five types of controller interrupts to activate the interrupt output signal separately. The interrupt system can be totally disabled by resetting bits 0 through 3 of the Interrupt Control Register (ICR). A selected interrupt can be enabled by setting the appropriate bits of this register to a logical 1.

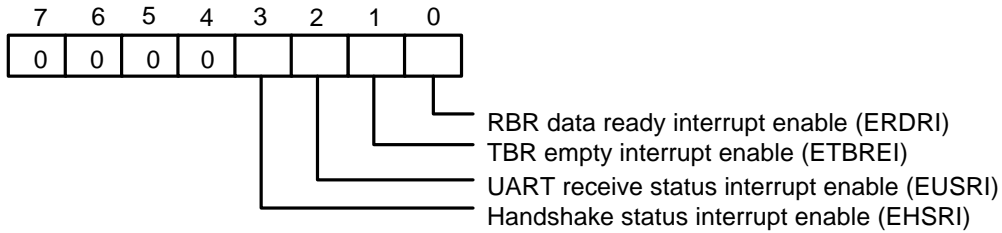

Bit 7-4: These four bits are always logic 0.

Bit 3: EHSRI. Setting this bit to a logical 1 enables the handshake status register interrupt.

Bit 2: EUSRI. Setting this bit to a logical 1 enables the UART status register interrupt.

Bit 1: ETBREI. Setting this bit to a logical 1 enables the TBR empty interrupt.

Bit 0: ERDRI. Setting this bit to a logical 1 enables the RBR data ready interrupt.

**3.2.8 Programmable Baud Generator (BLL/BHL) (Read/Write)**

Two 8-bit registers, BLL and BHL, compose a programmable baud generator that uses 24 MHz to generate a 1.8461 MHz frequency and divides it by a divisor from 1 to  $2^{16}-1$ . The output frequency of the baud generator is the baud rate multiplied by 16, and this is the base frequency for the transmitter and receiver. The table below illustrates the use of the baud generator with a frequency of 1.8461 MHz. In high-speed UART mode (refer to CR0C bit7 and CR0C bit6), the programmable baud generator directly uses 24 MHz and the same divisor as the normal speed divisor. In high-speed mode, the data transmission rate can be as high as 1.5M bps.

### 3.2.9 User-defined Register (UDR) (Read/Write)

This is a temporary register that can be accessed and defined by the user.

TABLE 3-5 BAUD RATE TABLE

BAUD RATE USING 24 MHZ TO GENERATE 1.8461 MHZ		
Desired Baud Rate	Decimal divisor used to generate 16X clock	Percent error difference between desired and actual
50	2304	**
75	1536	**
110	1047	0.18%
134.5	857	0.099%
150	768	**
300	384	**
600	192	**
1200	96	**
1800	64	**
2000	58	0.53%
2400	48	**
3600	32	**
4800	24	**
7200	16	**
9600	12	**
19200	6	**
38400	3	**
57600	2	**
115200	1	**
230400	4 <sup>Note 1</sup>	**
460800	2 <sup>Note 1</sup>	**
921600	1 <sup>Note 1</sup>	**
1.5M	1 <sup>Note 2</sup>	0%

Note 1: Only use in high speed mode, when FASTA/FASTB bits are set (refer to CR19 bit1 and CR19 bit0).

Note 2: Only use in high speed mode, when TURA/TURB bits are set (refer to CR0C bit7 and bit6).

\*\* The percentage error for all baud rates, except where indicated otherwise, is 0.16%

### 3.3 IR Port

In the W83877AF includes two serial ports, that is, UART A and UART B. The second serial port, UART B, also has built-in Infrared (IR) functions which include IrDA 1.0 SIR, IrDA 1.1 MIR (1.152M bps), IrDA FIR (4M bps), SHARP ASK-IR, and remote control (that support NEC, RC-5, advanced RC-5, and RECS-80 protocol).

#### 4.3.1 Advanced UART B Register Description

When bank select enable bit (ENBNKSEL, in CR2C.bit3) is set, UART B will be switched to Advanced UART B, and eight Register Sets can be accessed. These Register Sets control enhanced UART B, IR function switching such as SIR, MIR, or FIR. Also, a superior traditional UART B function can be used, such as 32-byte transmitter/receiver FIFO, non-encoding IRQ identify status register, and automatic flow control. The MIR/FIR and remote control registers are also defined in these Register Sets. The structure of the Register Sets is shown below.

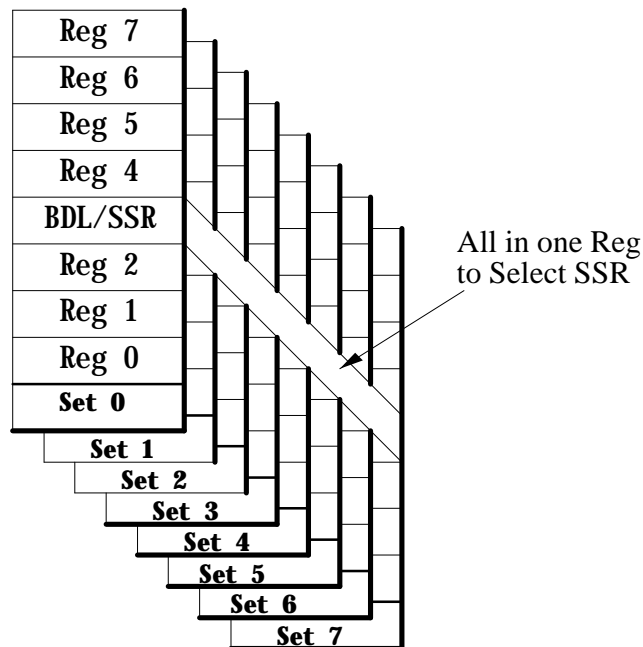

\*Set 0, 1 are legacy/Advanced UART Registers

\*Set 2~7 are Advanced UART Registers

All Sets registers have a common register which is *Sets Select Register (SSR)*, in order to switch to any Set when configuring this register. The summary description of these Sets is shown below.

Set	UART	IR Mode	Sets Description
0	i <sup>3</sup>	i <sup>3</sup>	Legacy/Advanced UART Control and Status Registers.
1	i <sup>3</sup>	i <sup>3</sup>	Legacy Baud Rate Divisor Register.
2		i <sup>3</sup>	Advanced UART Control and Status Registers.
3		i <sup>3</sup>	Version ID <i>and</i> Mapped Control Registers.
4		i <sup>3</sup>	Transmitter/Receiver/Timer Counter Registers <i>and</i> IR Control Registers.
5		i <sup>3</sup>	Flow Control <i>and</i> IR Control <i>and</i> Frame Status FIFO Registers.
6		i <sup>3</sup>	IR Physical Layer Control Registers
7		i <sup>3</sup>	Remote Control <i>and</i> IR front-end Module Selection Registers.

#### 4.3.2 Set0-Legacy/Advanced UART Control and Status Registers

Address Offset	Register Name	Register Description
0	<b>RBR/TBR</b>	Receiver/Transmitter Buffer Registers
1	<b>ICR</b>	Interrupt Control Register
2	<b>ISR/UFR</b>	Interrupt Status <i>or</i> UART FIFO Control Register
3	<b>UCR/SSR</b>	UART Control <i>or</i> Sets Select Register
4	<b>HCR</b>	Handshake Control Register
5	<b>USR</b>	UART Status Register
6	<b>HSR</b>	Handshake Status Register
7	<b>UDR/ESCR</b>	User Defined Register

##### 4.3.2.1 Set0.Reg0 - Receiver/Transmitter Buffer Registers (RBR/TBR) (Read/Write)

Receiver Buffer Register is read only and Transmitter Buffer Register is write only. These registers are described the same as legacy UART.

In legacy UART, this port only supports PIO mode. In advanced UART, if setup to MIR/FIR/Remote IR, this port will support DMA handshake function. Two DMA channels can be used, that is, one TX DMA channel and another RX DMA channel. Therefore, single DMA channel is also supported when the bit of D\_CHSW (DMA Channel Swap, in Set2.Reg2.Bit3) is set and the TX/RX DMA channel is swapped. Note that two DMA channels are defined in config register CR2A, which selects DMA channel or disables DMA channel. If RX DMA channel is enabled and TX DMA channel is disabled, then the single DMA channel will be selected.

**4.3.2.2 Set0.Reg1 - Interrupt Control Register (ICR)**

Mode	B7	B6	B5	B4	B3	B2	B1	B0
UART	0	0	0	0	EHSRI	EUSRI	ETBREI	ERDRI
Advanced UART	ETMRI	EFSFI	ETXTHI	EDMAI	EHSRI	EUSRI/TXURI	ETBREI	ERXTHI

Where UART is used to Legacy UART, and the functions for these bits are defined in the previous UART, the traditional SIR or ASK-IR based on the legacy UART also has the same definitions. The advanced UART functions, including Advanced SIR/ASK-IR, MIR, FIR, or Remote IR, are described as follows.

Bit 7: **ETMRI - Enable Timer Interrupt**

Write to 1; enable timer interrupt.

Bit 6: *MIR, FIR mode:*

**EFSFI - Enable Frame Status FIFO Interrupt**

Write to 1; enable frame status FIFO interrupt.

*Advanced SIR/ASK-IR, Remote IR:*

Not used.

Bit 5: *Advanced SIR/ASK-IR, MIR, FIR, Remote IR:*

**ETXTHI - Enable Transmitter Threshold Interrupt**

Write to 1; enable transmitter threshold interrupt.

Bit 4: *MIR, FIR, Remote IR:*

**EDMAI - Enable DMA Interrupt.**

Write to 1; enable DMA interrupt.

Bit 3: *Advanced UART/SIR/ASK-IR, MIR, FIR, Remote IR:*

**EHSRI - Enable HSR (Handshake Status Register) Interrupt**

Write to 1; enable handshake status register interrupt. Note that the bit IRHSSL (Infrared Handshake Select) should be set to 1, then this bit EHSRI is effective.

Bit 2: *Advanced SIR/ASK-IR:*

**EUSRI - Enable USR (UART Status Register) Interrupt**

Write to 1; enable UART status register interrupt.

*MIR, FIR, Remote Controller:*

**EHSRI/ETXURI - Enable USR Interrupt or Enable Transmitter Underrun Interrupt**

Write to 1; enable USR interrupt or enable transmitter underrun interrupt.

Bit 1: **ETBREI - Enable TBR (Transmitter Buffer Register) Empty Interrupt**

Write to 1; enable transmitter buffer register empty interrupt.

Bit 0: **ERBRI - Enable RDR (Receiver Buffer Register) Interrupt**

Write to 1; enable receiver buffer register interrupt.

**4.3.2.3 Set0.Reg2 - Interrupt Status Register/UART FIFO Control Register (ISR/UFR)**

(1) Interrupt Status Register: (Write Only)

Mode	B7	B6	B5	B4	B3	B2	B1	B0
Legacy UART	FIFO Enable	FIFO Enable	0	0	IID2	IID1	IID0	IP
Advanced UART	TMR_I	FSF_I	TXTH_I	DMA_I	HS_I	USR_I/ FEND_I	TXEMP_I	RXTH_I
Reset Value	0	0	1	0	0	0	1	0

**Legacy UART:** Same as previous register defined.

**Advanced UART:**

Bit 7: **TMR\_I - Timer Interrupt.**

Set to 1 when timer counts to 0. This bit will be affected by (1) the timer registers are defined in Set4.Reg0 and Set4.Reg1, (2) EN\_TMR(Enable Timer, in Set4.Reg2.Bit0) should be set to 1, (3) ENTMR\_I (Enable Timer Interrupt, in Set0.Reg1.Bit7) should be set to 1.

Bit 6: *MIR, FIR modes:*

**FSF\_I - Frame Status FIFO Interrupt.**

Set to 1 when Frame Status FIFO is equal to or larger than the threshold level or Frame Status FIFO time-out occurs. Clear to 0 when Frame Status FIFO is below the threshold level.

*Advanced UART/SIR/ASK-IR, Remote IR modes:*

Not used.

Bit 5: **TXTH\_I - Transmitter Threshold Interrupt.**

Set to 1 if the TBR (Transmitter Buffer Register) FIFO is below the threshold level. Clear to 0 if the TBR (Transmitter Buffer Register) FIFO is below the threshold level.

Bit 4: *MIR, FIR, Remote IR modes:*

**DMA\_I - DMA Interrupt.**

Set to 1 if the DMA controller 8237A sends a TC (Terminal Count) to I/O device which may be a Transmitter TC or a Receiver TC. Clear to 0 when this register is read.

Bit 3: **HS\_I - Handshake Status Interrupt.**

Set to 1 when the Handshake Status Register has a toggle. Clear to 0 when Handshake Status Register (HSR) is read. Note that in all IR modes including SIR, ASK-IR, MIR, FIR, and Remote Control, IR are defaulted to inactive except set IR Handshake Status Enable (IRHS\_EN) to 1.

Bit 2: *Advanced UART/SIR/ASK-IR modes:*

**USR\_I - UART Status Interrupt.**

Set to 1 when overrun, or parity bit, or stop bit, or silent byte detected error in the UART Status Register (USR) is set to 1. Clear to 0 when USR is read.

*MIR, FIR modes:*

**FEND\_I - Frame End Interrupt.**

Set to 1 when (1) a frame has a grace end to be detected where the frame signal is defined in the physical layer of IrDA version 1.1 (2) abort signal or illegal signal has been detected during receiving valid data. Clear to 0 when this register is read.

*Remote Controller mode:*

Not used.

Bit 1: **TXEMP\_I - Transmitter Empty.**

Set to 1 when transmitter (or, say, FIFO + Transmitter) is empty. Clear to 0 when this register is read.

Bit 0: **RXTH\_I - Receiver Threshold Interrupt.**

Set to 1 when (1) the Receiver Buffer Register (RBR) is equal to or larger than the threshold level, (2) RBR occurs time-out if the receiver buffer register has valid data and below the threshold level. Clear to 0 when RBR is less than threshold level from reading RBR.

(2) UART FIFO Control Register (UFR):

Mode	Bit 7	Bit 6	Bit 5	Bit 4	Bit 3	Bit 2	Bit 1	Bit 0
Legacy UART	RXFTL1 (MSB)	RXFTL0 (LSB)	0	0	0	TXF_RST	RXF_RST	EN_FIFO
Advanced UART	RXFTL1 (MSB)	RXFTL0 (LSB)	TXFTL1 (MSB)	TXFTL0 (LSB)	0	TXF_RST	RXF_RST	EN_FIFO
Reset Value	0	0	0	0	0	0	0	0

**Legacy UART:** The definition of this register is same as Legacy UART mode.

**Advanced UART:**

Bit 7, 6: **RXFTL1, 0 - Receiver FIFO Threshold Level**

Definition is same as Legacy UART, that is to determine the RXTH\_I to become 1 when the Receiver FIFO Threshold Level is equal or larger than the defined value shown below.

RXFTL1, 0 (Bit 7, 6)	RX FIFO Threshold Level (FIFO Size: 16-byte)	RX FIFO Threshold Level (FIFO Size: 32-byte)
00	1	1
01	4	4
10	8	16
11	14	26

Note that the FIFO Size is referred to SET2.Reg4.

Bit 5, 4: **TXFTL1, 0 - Transmitter FIFO Threshold Level**

To determine the TXTH\_I (Transmitter Threshold Level Interrupt) is set to 1 when the Transmitter Threshold Level is less than the programmed value shown as follows.

TXFTL1, 0 (Bit 5, 4)	TX FIFO Threshold Level (FIFO Size: 16-byte)	TX FIFO Threshold Level (FIFO Size: 32-byte)
00	1	1
01	3	7
10	9	17
11	13	25

Bit 3 ~0    **Same Legacy UART mode**

#### 4.3.2.4 Set0.Reg3 - UART Control Register/Set Select Register (UCR/SSR):

These two registers share the same address. In any Set, *Set Select Register (SSR)* can be programmed to desired Set, but UART Control Register can be programmed only in Set 0 and Set 1, that is, in other Sets programming this register will have no effect. The mapping of entry Set and programming value is shown as follows.

SSR Bits								Hex Value	Selected Set
7	6	5	4	3	2	1	0		
0	x	x	x	x	x	x	x	i D	Set 0
1	Any value but not used in SET 2~7							i D	Set1
1	1	1	0	0	0	0	0	0xE0	Set 2
1	1	1	0	0	1	0	0	0xE4	Set 3
1	1	1	0	1	0	0	0	0xE8	Set 4
1	1	1	1	1	1	0	0	0xEC	Set 5
1	1	1	1	0	0	0	0	0xF0	Set 6
1	1	1	1	0	1	0	0	0xF4	Set 7

**UART Control Register:** Defined legacy UART.

#### 4.3.2.5 Set0.Reg4 - Handshake Control Register (HCR)

Mode	B7	B6	B5	B4	B3	B2	B1	B0
Legacy UART	0	0	0	XLOOP	EN_IRQ	LP_RI	RTS	DTR
Advanced UART	AD_MD2	AD_MD1	AD_MD0	SIR_PLS	TX_WT	EN_DMA	RTS	DTR
Reset Value	0	0	0	0	0	0	0	0

**Legacy UART Register:** These registers are defined the same as in the previous description.

**Advanced UART Register:**

Bit 7~5 *Advanced UART/SIR/ASK-IR, MIR, FIR, Remote Controller modes:*

**AD\_MD2~0 - Advanced UART/Infrared mode Select.**

These registers are active when Advanced UART Select (ADV\_SL, in Set2.Reg2.Bit0) is set to 1. Operational mode selection is defined as follows. When the backward operation occurs these register will be reset to 0 and backward legacy UART mode.

AD_MD2~0 (Bit 7, 6, 5)	Selected Mode
000	Advanced <b>UART</b>
001	Low speed <b>MIR</b> (0.576M bps)
010	Advanced <b>ASK-IR</b>
011	Advanced <b>SIR</b>
100	High Speed <b>MIR</b> (1.152M bps)
101	<b>FIR</b> (4M bps)
110	<b>Consumer IR</b>
111	<b>Reserved</b>

Bit 4: *MIR, FIR modes:*

**SIR\_PLS - Send Infrared Pulse**

Write to 1 then automatically sends a 2 ms infrared pulse after physical frame end. In order to notify SIR that the high speed infrared is still in process when this pulse is sent. This bit will be automatically cleared by hardware.

*Other modes:*

Not used.

Bit 3: *MIR, FIR modes:*

**TX\_WT - Transmission Waiting**

If this bit sets to 1, the transmitter will wait for TX FIFO to reach threshold level or transmitter time-out which avoids short data bytes to want to transmit, before beginning to transmit data from TX FIFO. This is in order to avoid Underrun.

*Other modes:*

Not used.

Bit 2: *MIR, FIR modes:*

**EN\_DMA - Enable DMA**

Enable DMA function to transmit or receive. Before using this, the DMA channel should be select. If RX DMA channel is set and TX DMA channel is disabled, then the single DMA channel is used. In the single channel system, the bit of D\_CHSW (DMA channel swap, in Set 2.Reg2.Bit3) will determine RX DMA channel or TX DMA channel.

*Other modes:*

Not used.

Bit 1, 0: **RTS, DTR**

Functional definitions are the same as in legacy UART mode.

**4.3.2.6 Set0.Reg5 - UART Status Register (USR)**

Mode	B7	B6	B5	B4	B3	B2	B1	B0
Legacy UART	RFEI	TSRE	TBRE	SBD	NSER	PBER	OER	RDR
Advanced UART	LB_INFR	TSRE	TBRE	MX_LEX	PHY_ERR	CRC_ERR	OER	RDR
Reset Value	0	0	0	0	0	0	0	0

**Legacy UART Register:** These registers are defined the same as in the previous description.

**Advanced UART Register:**

Bit 7: *MIR, FIR modes:*

**LB\_INFR - Last Byte In Frame End**

Set to 1 when the last byte of a frame is in the FIFO bottom. This bit indicates that one frame is separated from another frame when RX FIFO has more than one frame.

Bit 6, 5: Same as legacy UART description.

Bit 4: *MIR, FIR modes:*

**MX\_LEX - Maximum Frame Length Exceed**

Set to 1 when frame length from the receiver has exceeded the programmed frame length, which is in SET4.Reg6 and Reg5. If this bit is set to 1, the receiver will not receive any data to RX FIFO.

Bit 3: *MIR, FIR modes:*

**PHY\_ERR - Physical Layer Error**

Set to 1 when an illegal data symbol is received, where the illegal data symbol is defined in physical layer of IrDA version 1.1. When this bit is set to 1, the decoder of receiver will be aborted, and a frame end signal is set to 1.

Bit 2: *MIR, FIR modes:*

**CRC\_ERR - CRC Error**

Set to 1 when an attached CRC is error.

Bit 1, 0: **OER - Overrun Error, RDR - RBR Data Ready**

Definitions are same as for legacy UART.

**4.3.2.7 Set0.Reg6 - Handshake Status Register (HSR)**

Mode	B7	B6	B5	B4	B3	B2	B1	B0
Legacy UART	DCD	RI	DSR	CTS	TDCD	FERI	TDSR	TCTS
Advanced UART	DCD	RI	DSR	CTS	TDCD	FERI	TDSR	TCTS
Reset Value	0	0	0	0	0	0	0	0

**Legacy/Advanced UART Register:** These registers are defined the same as in the previous description.

**4.3.2.8 Set0.Reg7 - User Defined Register (UDR/AUDR)**

Mode	Bit 7	Bit 6	Bit 5	Bit 4	Bit 3	Bit 2	Bit 1	Bit 0
Legacy UART	Bit 7	Bit 6	Bit 5	Bit 4	Bit 3	Bit 2	Bit 1	Bit 0
Advanced UART	FLC_ACT	UNDRN	RX_BSY/ RX_IP	LST_FE/ RX_PD	S_FEND	0	LB_SF	RX_TO
Reset Value	0	0	0	0	0	0	0	0

**Legacy UART Register:** These registers are defined the same as in the previous description.

**Advanced UART Register:**

Bit 7 *MIR, FIR modes:*

**FLC\_ACT - Flow Control Active**

Set to 1 when flow control occurs. Clear to 0 when this register is read. Note that this will be affected by Set5.Reg2 which controls the SIR mode switches to MIR/FIR mode or when MIR/FIR mode operated in DMA function switches to SIR mode.

Bit 6 *MIR, FIR modes:*

**UNDRN - Underrun**

Set to 1 when transmitter is empty *and* not set S\_FEND (in this register bit 3) operated in PIO mode or not TC (Terminal Count) operated in DMA mode. Clear to 0 when write to 1.

- Bit 5     *MIR, FIR modes:*  
          **RX\_BSY - Receiver Busy**  
          Set to 1 when receiver is busy or active in process.  
*Remote IR mode:*  
          **RX\_IP - Receiver in Process**  
          Set to 1 when receiver is in process.
- Bit 4:     *MIR, FIR modes:*  
          **LST\_FE - Lost Frame End**  
          Set to 1 when a frame end for an entire frame is lost. Clear to 0 when read this register.  
*Remote IR modes:*  
          **RX\_PD - Receiver Pulse Detected**  
          Set to 1 when one or more than one remote pulses are detected. Clear to 0 when read this register.
- Bit 3     *MIR, FIR modes:*  
          **S\_FEND - Set a Frame End**  
          Write to 1 when wanting to terminate the frame; that is, the procedure of PIO command is  
          *An Entire Frame = Write Frame Data (First) + Write S\_FEND (Last)*  
          This bit should be set to 1, if used in PIO mode, to avoid transmitter underrun. Note that this bit S\_FEND is set to 1, that is, equivalent to TC (Terminal Count) in DMA mode. This bit should therefore be set to 0 in DMA mode.
- Bit 2:     Reserved.
- Bit 1:     *MIR, FIR modes:*  
          **LB\_SF - Last Byte Stay in FIFO**  
          Set to 1 that indicates one or more than one frame end still stay in receiver FIFO.
- Bit 0:     *MIR, FIR, Remote IR modes:*  
          **RX\_TO - Receiver FIFO or Frame Status FIFO time-out**  
          Set to 1 when receiver FIFO or frame status FIFO occurs time-out

**4.3.3 Set1 - Legacy Baud Rate Divisor Register**

Address Offset	Register Name	Register Description
0	<b>BLL</b>	Baud Rate Divisor Latch (Low Byte)
1	<b>BHL</b>	Baud Rate Divisor Latch (High Byte)
2	<b>ISR/UFR</b>	Interrupt Status <i>or</i> UART FIFO Control Register
3	<b>UCR/SSR</b>	UART Control <i>or</i> Sets Select Register
4	<b>HCR</b>	Handshake Control Register
5	<b>USR</b>	UART Status Register
6	<b>HSR</b>	Handshake Status Register
7	<b>UDR/ESCR</b>	User Defined Register

**4.3.3.1 Set1.Reg0~1 - Baud Rate Divisor Latch (BLL/BHL)**

The two registers of BLL and BHL are baud rate divisor latch in the legacy UART/SIR/ASK-IR mode. Read/Write these registers, if set in Advanced UART mode, will occur backward operation, that is, will go to legacy UART mode and clear some register values shown in the table below.

Set & Register	Advanced Mode DIS_BACK= $\times$	Legacy Mode DIS_BACK=0
Set 0.Reg 4	Bit 7~5	-
Set 2.Reg 2	Bit 0, 5, 7	Bit 5, 7
Set 4.Reg 3	Bit 2, 3	-

Note that DIS\_BACK=1 (Disable Backward operation) in legacy UART/SIR/ASK-IR mode will not affect any register which can operate legacy SIR/ASK-IR.

**4.3.3.2 Set1.Reg 2~7**

These registers are defined the same as the Set 0 registers.

#### 4.3.4 Set2 - Interrupt Status or UART FIFO Control Register (ISR/UFR)

These registers are only used in advanced modes.

Address Offset	Register Name	Register Description
0	ABLL	Advanced Baud Rate Divisor Latch (Low Byte)
1	ABHL	Advanced Baud Rate Divisor Latch (High Byte)
2	ADCR1	Advanced UART Control Register 1
3	SSR	Sets Select Register
4	ADCR2	Advanced UART Control Register 2
5	Reserved	-
6	TXFDTH	Transmitter FIFO Depth
7	RXFDTH	Receiver FIFO Depth

##### 4.3.4.1 Reg0, 1 - Advanced Baud Rate Divisor Latch (ABLL/ABHL)

The two registers are the same as the legacy UART baud rate divisor latch in SET 1. Reg0~1. When using advanced UART/SIR/ASK-IR mode operation, these registers should be programmed to set baud rate. This is to prevent a backward operation occurring.

##### 4.3.4.2 Reg2 - Advanced UART Control Register 1 (ADCR1)

Mode	Bit 7	Bit 6	Bit 5	Bit 4	Bit 3	Bit 2	Bit 1	Bit 0
Advanced UART	BR_OUT	-	EN_LOUT	D_CHSW	ALOOP	DMATHL	DMA_F	ADV_SL
Reset Value	0	0	0	0	0	0	0	0

Bit 7: **BR\_OUT - Baud Rate Clock Output**

Write to 1 enables the programmed baud rate clock to output to DTR pin. This bit is the only test baud rate divisor.

Bit 6: **Reserved**, write 0.

Bit 5: **EN\_LOUT - Enable Loopback Output**

Write to 1 enables output of transmitter data to IRTX pin during doing loopback operation. Setting this bit can check output data with internal data.

Bit 4: **D\_CHSW - DMA TX/RX Channel Swap**

If using signal DMA channel in MIR/FIR mode, then the DMA channel can be swapped.

D_CHSW	DMA Channel Selected
0	Receiver (Default)
1	Transmitter

Write to 1 enables output data during the ALOOP=1.

Bit 3: **ALOOP - All mode Loopback**  
Write to 1 enables loopback in all modes.

Bit 2: **DMATHL - DMA Threshold Level**  
Sets DMA threshold level as shown in the table below.

DMATHL	TX FIFO Threshold		RX FIFO Threshold (16/32-Byte)
	16-Byte	32-Byte	
0	13	13	4
1	23	7	10

Bit 1: **DMA\_F - DMA Fairness**

DMA_F	Function Description
0	DMA request (DREQ) is forced inactive after 10.5us
1	No effect on DMA request.

Bit 0: **ADV\_SL - Advanced mode Select**  
Write to 1 selects advanced mode.

#### 4.3.4.3 Reg3 - Sets Select Register (SSR)

Reading this register returns E0<sub>16</sub>. Write it to select other register Set.

Reg.	Bit 7	Bit 6	Bit 5	Bit 4	Bit 3	Bit 2	Bit 1	Bit 0
SSR	SSR7	SSR6	SSR5	SSR4	SSR3	SSR2	SRR1	SRR0
default Value	1	1	1	0	0	0	0	0

#### 4.3.4.4 Reg4 - Advanced UART Control Register 2 (ADCR2)

Mode	Bit 7	Bit 6	Bit 5	Bit 4	Bit 3	Bit 2	Bit 1	Bit 0
Advanced UART	DIS_BAC K	-	PR_DIV1	PR_DIV0	RX_FSZ1	RX_FSZ0	TX_FSZ1	TXFSZ0
Reset Value	0	0	0	0	0	0	0	0

Bit 7: **DIS\_BACK - Disable Backward Operation**  
Write to 1, read or write BLL or BHL (Baud rate Divisor Latch Register, in Set1.Reg0~1) will disable backward legacy UART mode. When using legacy SIR/ASK-IR mode, this bit should be set to 1 to avoid backward operation.

Bit 6: **Reserved**, write 0.

**Bit 5, 4: PR\_DIV1~0 - Pre-Divisor 1~0.**

These bits select pre-divisor for external input clock 24M Hz. The clock through the pre-divisor then inputs to baud rate divisor of UART.

PR_DIV1~0	Pre-divisor	Max. Baud Rate
00	13.0	115.2K bps
01	1.625	921.6K bps
10	6.5	230.4K bps
11	1	1.5M bps

**Bit 3, 2: RX\_FSZ1~0 - Receiver FIFO Size 1~0**

These bits setup receiver FIFO size when FIFO is enabled.

RX_FSZ1~0	RX FIFO Size
00	16-Byte
01	32-Byte
1X	Reserved

**Bit 2, 0: TX\_FSZ1~0 - Transmitter FIFO Size 1~0**

These bits setup transmitter FIFO size when FIFO is enabled.

TX_FSZ1~0	TX FIFO Size
00	16-Byte
01	32-Byte
1X	Reserved

**4.3.4.5 Reg6 - Transmitter FIFO Depth (TXFDTH) (Read Only)**

Mode	Bit 7	Bit 6	Bit 5	Bit 4	Bit 3	Bit 2	Bit 1	Bit 0
Advanced UART	0	0	TXFD5	TXFD4	TXFD3	TXFD2	TXFD1	TXFD1
Reset Value	0	0	0	0	0	0	0	0

Bit 7~6: **Reserved**, Read 0.

Bit 5~0: Reading these bits will return the current transmitter FIFO depth, that is, how many bytes there are in the transmitter FIFO.

#### 4.3.4.6 Reg7 - Receiver FIFO Depth (RXFDTH) (Read Only)

Mode	Bit 7	Bit 6	Bit 5	Bit 4	Bit 3	Bit 2	Bit 1	Bit 0
Advanced UART	0	0	RXFD5	RXFD4	RXFD3	RXFD2	RXFD1	RXFD1
Reset Value	0	0	0	0	0	0	0	0

Bit 7~6: **Reserved**, Read 0.

Bit 5~0: Read these bits will return the current receiver FIFO depth, that is, how many bytes there are in the receiver FIFO.

#### 4.3.5 Set3 - Version ID and Mapped Control Registers

Address Offset	Register Name	Register Description
0	<b>AUID</b>	Advanced UART ID
1	<b>MP_UCR</b>	Mapped UART Control Register
2	<b>MP_UFR</b>	Mapped UART FIFO Control Register
3	<b>SSR</b>	Sets Select Register
4	<b>Reversed</b>	-
5	<b>Reserved</b>	-
6	<b>Reserved</b>	-
7	<b>Reserved</b>	-

##### 4.3.5.1 Reg0 - Advanced UART ID (AUID)

This register is read only. Indicates advanced UART version ID. Read it and return 1X<sub>16</sub>.

##### 4.3.5.2 Reg1 - Mapped UART Control Register (MP\_UCR)

Read only. Reading this register that returns UART Control Register value of Set 0.

#### 4.3.5.3 Reg2 - Mapped UART FIFO Control Register (MP\_UFR)

Read only. Reading this register returns UART FIFO Control Register (UFR) value of SET 0.

#### 4.3.5.4 Reg3 - Sets Select Register (SSR)

Reading this register returns E4<sub>16</sub>. Write it to select other register Set.

Reg.	Bit 7	Bit 6	Bit 5	Bit 4	Bit 3	Bit 2	Bit 1	Bit 0
SSR	SSR7	SSR6	SSR5	SSR4	SSR3	SSR2	SRR1	SRR0
default Value	1	1	1	0	0	1	0	0

#### 4.3.6 Set4 - TX/RX/Timer counter registers and IR control registers.

Address Offset	Register Name	Register Description
0	TMRL	Timer Value Low Byte
1	TMRH	Timer Value High Byte
2	IR_MSL	Infrared mode Select
3	SSR	Sets Select Register
4	TFRLL	Transmitter Frame Length Low Byte
5	TFRLH	Transmitter Frame Length High Byte
6	RFRL	Receiver Frame Length Low Byte
7	RFRLH	Receiver Frame Length High Byte

##### 4.3.6.1 Set4.Reg0, 1 - Timer Value Register (TMRL/TMRH)

This is a 12-bit timer with resolution of 1 ms, that is, the programmed maximum time is  $2^{12}-1$  ms. The timer is a down-counter. The timer starts down count when the bit EN\_TMR (Enable Timer) of Set4.Reg2. is set to 1. When the timer down counts to zero and EN\_TMR=1, the TMR\_I is set to 1. When the counter down counts to zero, a new initial value will be re-loaded into timer counter.

##### 4.3.6.2 Set4.Reg2 - Infrared mode Select (IR\_MSL)

Mode	Bit 7	Bit 6	Bit 5	Bit 4	Bit 3	Bit 2	Bit 1	Bit 0
Advanced UART	-	-	-	-	IR_MSL1	IR_MSL0	TMR_TST	EN_TMR
Reset Value	0	0	0	0	0	0	0	0

Bit 7~4: **Reserved**, write to 0.

Bit 3, 2: **IR\_MSL1, 0 - Infrared mode Select**

Select legacy UART or SIR or ASK-IR mode. Note that using legacy SIR/ASK-IR should set DIS\_BACK=1 to avoid backward operation when programming baud rate. Mode selected is shown below. Note that to avoid legacy backward operation, the bit of DIS\_BACK (Disable Backward, in Set2.Reg4. Bit7) should be set to 1 when legacy ASK-IR mode or legacy SIR mode is selected.

IR_MSL1, 0	Operation Mode Selected
00	Legacy <b>UART</b>
01	Reserved
10	Legacy <b>ASK-IR</b>
11	Legacy <b>SIR</b>

Bit 1: **TMR\_TST - Timer Test**

Write to 1 will cause reading the TMRL/TMRH will return the programmed values of TMRL/TMRH, that is, it does not return down count counter value. This bit is for test timer register.

Bit 0: **EN\_TMR - Enable Timer**

Write to 1 enables the timer.

**4.3.6.3 Set4.Reg3 - Set Select Register (SSR)**

Reading this register returns E8<sub>16</sub>. A write to this register selects other Set.

Reg.	Bit 7	Bit 6	Bit 5	Bit 4	Bit 3	Bit 2	Bit 1	Bit 0
SSR	SSR7	SSR6	SSR5	SSR4	SSR3	SSR2	SRR1	SRR0
default Value	1	1	1	1	1	0	0	0

**4.3.6.4 Set4.Reg4, 5 - Transmitter Frame Length (TFRL/TFRLH)**

Reg.	Bit 7	Bit 6	Bit 5	Bit 4	Bit 3	Bit 2	Bit 1	Bit 0
TFRL	bit 7	bit 6	bit 5	bit 4	bit 3	bit 2	bit 1	bit 0
Reset Value	0	0	0	0	0	0	0	0
TFRLH	-	-	-	bit 12	bit 11	bit 10	bit 9	bit 8
Reset Value	-	-	-	0	0	0	0	0

These are 13-bit registers. A write to these registers will cause the transmitter frame length of a package be programmed. These registers are only used in APM=1 (automatic package mode, Set5.Reg4.bit5). When APM=1, the physical layer will split data stream to a programmed frame length if the transmitted data is larger than the programmed frame length. When these registers are read, they will return the number of bytes which have not been transmitted from a frame length programmed.

#### 4.3.6.5 Set4.Reg6, 7 - Receiver Frame Length (RFRL/RFRLH)

Reg.	Bit 7	Bit 6	Bit 5	Bit 4	Bit 3	Bit 2	Bit 1	Bit 0
RFRL	bit 7	bit 6	bit 5	bit 4	bit 3	bit 2	bit 1	bit 0
Reset Value	0	0	0	0	0	0	0	0
RFRLH	-	-	-	bit 12	bit 11	bit 10	bit 9	bit 8
Reset Value	-	-	-	0	0	0	0	0

These are 13-bit registers which combine to form a 13-bit up counter. By programming these registers, the receiver frame length will be limited to the programmed frame length. If the received frame length is larger than the programmed receiver frame length, the bit of MX\_LEX (Maximum Length Exceed) will be set to 1. Simultaneously, the receiver will not receive any data to RX FIFO until the next start flag in the next frame, which is defined in the physical layer IrDA 1.1, is reached; the received data then begins to write to RX FIFO. Reading these registers will return the number of received data bytes from the receiver for a frame.

#### 4.3.7 Set 5 - Flow control and IR control and Frame Status FIFO registers

Address Offset	Register Name	Register Description
0	FCBLL	Flow Control Baud Rate Divisor Latch Register (Low Byte)
1	FCBHL	Flow Control Baud Rate Divisor Latch Register (High Byte)
2	FC_MD	Flow Control Mode Operation
3	SSR	Sets Select Register
4	IRCFG1	Infrared Config Register
5	FS_FO	Frame Status FIFO Register
6	RFRLFL	Receiver Frame Length FIFO Low Byte
7	RFRLFH	Receiver Frame Length FIFO High Byte

##### 4.3.7.1 Set5.Reg0, 1 - Flow Control Baud Rate Divisor Latch Register (FCDLL/ FCDHL)

If flow control occurs from MIR/FIR mode change to SIR mode, then the pre-programming baud rate of FCBLL/FCBHL is loaded to advanced baud rate divisor latch (ADBLL/ADBHL).

**4.3.7.2 Set5.Reg2 - Flow Control mode Operation (FC\_MD)**

These registers control flow control mode operation as shown in the table below.

Reg.	Bit 7	Bit 6	Bit 5	Bit 4	Bit 3	Bit 2	Bit 1	Bit 0
FC_MD	FC_MD2	FC_MD1	FC_MD0	-	FC_DSW	EN_FD	EN_BRFC	EN_FC
Reset Value	0	0	0	0	0	0	0	0

**Bit 7~5 FC\_MD2 - Flow Control mode**

When flow control state occurs, these bits will be loaded to AD\_MD2~0 of advanced HSR (Handshake Status Register). These three bits are defined the same as AD\_MD2~0.

Bit 4: **Reserved**, write 0.

**Bit 3: FC\_DSW - Flow Control DMA Channel Swap**

Write to 1, when flow control state occurs enables DMA channel of both transmitter and receiver to be swapped.

FC_DSW	Next Mode After Flow Control Occurred
0	Receiver Channel
1	Transmitter Channel

**Bit 2: EN\_FD - Enable Flow DMA Control**

Write to 1 enables use of DMA channel when flow control has occurred.

**Bit 1: EN\_BRFC - Enable Baud Rate Flow Control**

Write to 1 enables FC\_BLL/FC\_BHL (Flow Control Baud Rate Divider Latch, in Set5.Reg1~0) to be loaded to advanced baud rate divisor latch (ADBLL/ADBHL, in Set2.Reg1~0).

**Bit 0: EN\_FC - Enable Flow Control**

Write to 1 allows use of flow control function and activation of bit 7~1 of this register.

**4.3.7.3 Set5.Reg3 - Sets Select Register (SSR)**

A write to this register will change Set of register. Reading this register will return EC<sub>16</sub>.

Reg.	Bit 7	Bit 6	Bit 5	Bit 4	Bit 3	Bit 2	Bit 1	Bit 0
SSR	SSR7	SSR6	SSR5	SSR4	SSR3	SSR2	SRR1	SRR0
default Value	1	1	1	0	1	1	0	0

**4.3.7.4 Set5.Reg4 - Infrared Config Register 1 (IRCFG1)**

Reg.	Bit 7	Bit 6	Bit 5	Bit 4	Bit 3	Bit 2	Bit 1	Bit 0
IRCFG1	-	FSF_TH	FEND_M	AUX_RX	-	-	IRHSSL	IR_FULL
Reset Value	0	0	0	0	0	0	0	0

Bit 7: **Reserved**, write 0.

Bit 6: **FSF\_TH - Frame Status FIFO Threshold**

Set this bit to determine the frame status FIFO threshold level and to generate the FSF\_I. The threshold level values are defined as follows.

FSF_TH	Status FIFO Threshold Level
0	2
1	4

Bit 5: **FEND\_MD - Frame End mode**

Write to 1 enables hardware automatically to split same length frame defined Set4.Reg4 and Set4.Reg5, i.e., TFRLL/TFRLH.

Bit 4: **AUX\_RX - Auxiliary Receiver Pin**

Write to 1 selects IRRX input pin. (Refer to Set7.Reg7.Bit5)

Bit 3~2: **Reserved**, write 0.

Bit 1: **IRHSSL - Infrared Handshake Status Select**

Write to 0 brings the HSR (Handshake Status Register) into normal operation the same as UART. Write to 1 disables HSR; reading HSR will then return 30<sub>16</sub>.

Bit 0: **IR\_FULL - Infrared Full Duplex Operation**

Write to 0 will cause IR function to operate in half duplex. Write to 1 will cause IR function to operate in full duplex.

**4.3.7.5 Set5.Reg5 - Frame Status FIFO Register (FS\_FO)**

This register are indicated the FIFO bottom of frame status.

Reg.	Bit 7	Bit 6	Bit 5	Bit 4	Bit 3	Bit 2	Bit 1	Bit 0
FS_FO	FSFDR	LST_FR	-	MX_LEX	PHY_ERR	CRC_ERR	RX_OV	FSF_OV
Reset Value	0	0	0	0	0	0	0	0

- Bit 7: **FSFDR - Frame Status FIFO Data Ready**  
Indicates that there is valid data in frame status FIFO bottom.
- Bit 6: **LST\_FR - Lost Frame**  
Set to 1 when one or more than one frame has been lost.
- Bit 5: **Reserved.**
- Bit 4: **MX\_LEX - Maximum Frame Length Exceed**  
Set to 1 when programmed maximum frame length defined Set4.Reg6 and Set4.Reg7 are exceeded. This bit is frame status FIFO bottom. Reading this bit will return a valid value when FSFDR=1 (Frame Status FIFO Data Ready).
- Bit 3: **PHY\_ERR - Physical Error**  
During receiving data, any physical layer error, defined IrDA 1.1, will be set to 1 in this bit. This bit is frame status FIFO bottom. Reading this bit will return a valid value when FSFDR=1 (Frame Status FIFO Data Ready).
- Bit 2: **CRC\_ERR - CRC Error**  
Set to 1 when a bad CRC is received in a frame. This CRC belongs to physical layer defined in IrDA 1.1. This bit is frame status FIFO bottom. Reading this bit will return a valid value when FSFDR=1 (Frame Status FIFO Data Ready).
- Bit 1: **RX\_OV - Received Data Overrun**  
Set to 1 when Received data in FIFO overrun occurs.
- Bit 0: **FSF\_OV - Frame Status FIFO Overrun**  
Set to 1 When frame status FIFO overrun occurs.

#### 4.3.7.5 Set5.Reg6, 7 - Receiver Frame Length FIFO (RFLFL/RFLFH) or Lost Frame Number (LST\_NU)

Reg.	Bit 7	Bit 6	Bit 5	Bit 4	Bit 3	Bit 2	Bit 1	Bit 0
RFLFL/ LST_NU	Bit 7	Bit 6	Bit 5	Bit 4	Bit 3	Bit 2	Bit 1	Bit 0
Reset Value	0	0	0	0	0	0	0	0
RFLFH	-	-	-	Bit 12	Bit 11	Bit 10	Bit 9	Bit 8
Reset Value	0	0	0	0	0	0	0	0

#### **Receiver Frame Length FIFO (RFLFL/RFLFH):**

These registers are 13-bit. Reading these registers will return received frame length. When read the register of *RFLFH* will pop-up another frame status and frame length if FSFDR=1 (Set5.Reg4.Bit7).

**Lost Frame Number (LST\_NU):**

When LST\_FR=1 (Set5.Reg4. Bit6), Reg6 is replaced to LST\_NU, that is 8-bit register and read RFLFH will return 0. When read the register of RFLFH will pop-up another frame status and frame length if FSFDR=1 (Set5.Reg4.Bit7).

**4.3.8 Set6 - IR Physical Layer Control Registers**

Address Offset	Register Name	Register Description
0	IR_CFG2	Infrared Config Register 2
1	MIR_PW	MIR (1.152M bps or 0.576M bps) Pulse Width
2	SIR_PW	SIR Pulse Width
3	SSR	Sets Select Register
4	HIR_FNU	High Speed Infrared Flag Number
5	Reserved	-
6	Reserved	-
7	Reserved	-

**4.3.8.1 Set6.Reg0 - Infrared Config Register 2 (IR\_CFG2)**

This register config ASK-IR, MIR, FIR operation function.

Reg.	Bit 7	Bit 6	Bit 5	Bit 4	Bit 3	Bit 2	Bit 1	Bit 0
IR_CFG2	SHMD_N	SHDM_N	FIR_CRC	MIR_CRC	-	INV_CRC	DIS_CRC	-
Reset Value	0	0	1	0	0	0	0	0

Bit 7: **SHMD\_N - ASK-IR Modulation Disable**

SHMD_N	Modulation Mode
0	SOUT modulate 500K Hz Square Wave
1	Re-rout SOUT

Bit 6: **SHDM\_N - ASK-IR Demodulation Disable**

SHDM_N	Demodulation Mode
0	Demodulation 500K Hz
1	Re-rout SIN

Bit 5: **FIR\_CRC - FIR (4M bps) CRC Type**

FIR_CRC	CRC Type
0	16-bit CRC
1	32-bit CRC

Note that the 16/32-bit CRC are defined in IrDA 1.1 physical layer.

Bit 4: **MIR\_CRC - MIR (1.152M/0.576M bps) CRC Type**

MIR_CRC	CRC Type
0	16-bit CRC
1	32-bit CRC

Bit 2: **INV\_CRC - Inverting CRC**

Write to 1 causes CRC inverted output in physical layer.

Bit 1: **DIS\_CRC - Disable CRC**

Write to 1 causes the transmitter not to transmit CRC in physical layer.

Bit 0: **Reserved**, write 1.

#### 4.3.8.2 Set6.Reg1 - MIR (1.152M/0.576M bps) Pulse Width

Reg.	Bit 7	Bit 6	Bit 5	Bit 4	Bit 3	Bit 2	Bit 1	Bit 0
MIR_PW	-	-	-	M_PW4	M_PW3	M_PW2	M_PW1	M_PW0
Reset Value	0	0	0	0	1	0	1	0

This 5-bit register is set MIR output pulse width.

M_PW4~0	MIR Pulse Width (1.152M bps)	MIR Output Width (0.576M bps)
00000	0 ns	0 ns
00001	20.83 ns	41.66 ns
00010	41.66 (==20.83*2) ns	83.32 (==41.66*2) ns
...	...	...
$k_{10}$	$20.83 * k_{10}$ ns	$41.66 * k_{10}$ ns
...	...	...
11111	645 ns	1290 ns

**4.3.8.3 Set6.Reg2 - SIR Pulse Width**

Reg.	Bit 7	Bit 6	Bit 5	Bit 4	Bit 3	Bit 2	Bit 1	Bit 0
SIR_PW	-	-	-	S_PW4	S_PW3	S_PW2	S_PW1	S_PW0
Reset Value	0	0	0	0	0	0	0	0

This 5-bit register is set SIR output pulse width.

S_PW4~0	SIR Output Pulse Width
00000	3/16 bit time of UART
01101	1.6 us
Others	1.6 us

**4.3.8.4 Set6.Reg3 - Set Select Register**

A write to this register will result in going to other Set. Reading this register returns F0<sub>16</sub>.

Reg.	Bit 7	Bit 6	Bit 5	Bit 4	Bit 3	Bit 2	Bit 1	Bit 0
SSR	SSR7	SSR6	SSR5	SSR4	SSR3	SSR2	SRR1	SRR0
default Value	1	1	1	1	0	0	0	0

**4.3.8.5 Set6.Reg4 - High Speed Infrared Beginning Flag Number (HIR\_FNU)**

Reg.	Bit 7	Bit 6	Bit 5	Bit 4	Bit 3	Bit 2	Bit 1	Bit 0
HIR_FNU	M_FG3	M_FG2	M_FG1	M_FG0	F_FL3	F_FL2	F_FL1	F_FLO
Reset Value	0	0	1	0	1	0	1	0

**Bit 7~4: M\_FG3~0 - MIR beginning Flag Number**

These bits define the number of transmitter *Start Flag* of MIR. Note that the number of MIR start flag should be equal to or more than *two* which is defined in IrDA 1.1 physical layer. The default value is 2.

M_FG3~0	Beginning Flag Number
0000	Reserved
0001	1
0010	2 (Default)
0011	3
0100	4
0101	5
0110	6
0111	8
1000	10
1001	12
1010	16
1011	20
1100	24
1101	28
1110	32
1111	Reserved

**Bit 3~0: F\_FG3~0 - FIR Beginning Flag Number**

These bits define the number of transmitter *Preamble Flag* in FIR. Note that the number of FIR start flag should be equal to *sixteen* which is defined in IrDA 1.1 physical layer. The default value is 16.

M_FG3~0	Beginning Flag Number
0000	Reserved
0001	1
0010	2
0011	3
0100	4
0101	5
0110	6
0111	8
1000	10
1001	12
1010	16 (Default)
1011	20
1100	24
1101	28
1110	32
1111	Reserved

**4.3.9 Set7 - Remote control and IR module selection registers**

Address Offset	Register Name	Register Description
0	RIR_RXC	Remote Infrared Receiver Control
1	RIR_TXC	Remote Infrared Transmitter Control
2	RIR_CFG	Remote Infrared Config Register
3	SSR	Sets Select Register
4	IRM_SL1	Infrared Module (Front End) Select 1
5	IRM_SL2	Infrared Module Select 2
6	IRM_SL3	Infrared Module Select 3
7	IRM_CR	Infrared Module Control Register

**4.3.9.1 Set7.Reg0 - Remote Infrared Receiver Control (RIR\_RXC)**

Reg.	Bit 7	Bit 6	Bit 5	Bit 4	Bit 3	Bit 2	Bit 1	Bit 0
RIR_RXC	RX_FR2	RX_FR1	RX_FR0	RX_FSL4	RX_FSL3	RX_FSL2	RX_FSL1	RX_FSL0
default Value	0	0	1	0	1	0	0	1

This register defines frequency ranges of receiver remote IR.

Bit 7~5: **RX\_FR2~0 - Receiver Frequency Range 2~0.**

These bits select the input frequency of the receiver ranges. For the input signal, that is through a band pass filter, i.e., the frequency of the input signal is located at this defined range then the signal will be received.

Bit 4~0: **RX\_FSL4~0 - Receiver Frequency Select 4~0.**

Select the receiver operation frequency.

Table: Low Frequency range select of receiver.

RX_FSL4~0	RX_FR2~0 (Low Frequency)					
	001		010		011	
	Min.	Max.	Min.	Max.	Min.	Max.
00010	26.1	29.6	24.7	31.7	23.4	34.2
00011	28.2	32.0	26.7	34.3	25.3	36.9
00100	29.4	33.3	27.8	35.7	26.3	38.4
00101	30.0	34.0	28.4	36.5	26.9	39.3
00110	31.4	35.6	29.6	38.1	28.1	41.0
00111	32.1	36.4	30.3	39.0	28.7	42.0
01000	32.8	37.2	31.0	39.8	29.4	42.9
01001	<b>33.6*</b>	<b>38.1*</b>	31.7	40.8	30.1	44.0
01011	34.4	39.0	32.5	41.8	30.8	45.0
01100	36.2	41.0	34.2	44.0	32.4	47.3
01101	37.2	42.1	35.1	45.1	33.2	48.6
01111	38.2	43.2	36.0	46.3	34.1	49.9
10000	40.3	45.7	38.1	49.0	36.1	52n.7
10010	41.5	47.1	39.2	50.4	37.2	54.3
10011	42.8	48.5	40.4	51.9	38.3	56.0
10101	44.1	50.0	41.7	53.6	39.5	57.7
10111	45.5	51.6	43.0	55.3	40.7	59.6
11010	48.7	55.2	46.0	59.1	43.6	63.7
11011	50.4	57.1	47.6	61.2	45.1	65.9
11101	54.3	61.5	51.3	65.9	48.6	71.0

Note that the other non-defined values are reserved.

Table: High Frequency range select of receiver

RX_FSL4~0	RX_FR2~0 (High Frequency)	
	001	
	Min.	Max.
00011	355.6	457.1
01000	380.1	489.8
01011	410.3	527.4

Note that the other non-defined values are reserved.

Table: SHARP ASK-IR receiver frequency range select.

RX_FSL4~0 (SHARP ASK-IR)												
RX_FR2~0	001		010		011		100		101		110	
-	480.0*	533.3*	457.1	564.7	436.4	600.0	417.4	640.0	400.0	685.6	384.0	738.5

Note that the other non-defined values are reserved.

#### 4.3.9.1 Set7.Reg1 - Remote Infrared Transmitter Control (RIR\_TXC)

Reg.	Bit 7	Bit 6	Bit 5	Bit 4	Bit 3	Bit 2	Bit 1	Bit 0
RIR_TXC	TX_PW2	TX_PW1	TX_PW0	TX_FSL4	TX_FSL3	TX_FSL2	TX_FSL1	TX_FSL0
default Value	0	1	1	0	1	0	0	1

This Register defines the transmitter frequency and pulse width of remote IR.

Bit 7~5: **TX\_PW2~0 - Transmitter Pulse Width 2~ 0.**

Selects the transmission pulse width.

TX_PW2~0	Low Frequency	High Frequency
010	6 ms	0.7 ms
011	7 ms	0.8 ms
100	9 ms	0.9 ms
101	10.6 ms	1.0 ms

Note that the other non-defined TX\_PW are reserved.

Bit 4~0: **TX\_FSL4~0 - Transmitter Frequency Select 4~0.**

Selects the transmission frequency.

Table: Low frequency selected.

TX_FSL4~0	Low Frequency
00011	30K Hz
00100	31K HZ
...	...
11101	56K Hz

Note that the other non-defined TX\_FSL4~0 are reserved.

Table: High frequency selected.

TX_FSL4~0	High Frequency
00011	400K Hz
01000	450K Hz
01011	480K Hz

Note that the other non-defined TX\_FSL4~0 are reserved.

4.3.9.2 Set7.Reg2 - Remote Infrared Config Register (RIR\_CFG)

Reg.	Bit 7	Bit 6	Bit 5	Bit 4	Bit 3	Bit 2	Bit 1	Bit 0
RIR_CFG	P_PNB	SMP_M	RXCFS	-	TX_CFS	RX_DM	TX_MM1	TX_MM0
default Value	0	0	0	0	0	0	0	0

Bit 7: **P\_PNB: Programming Pulse Number Coding.**

Write to 1 causes programming pulse number coding to be selected. The code format is defined as follows.

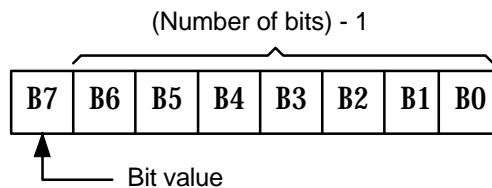

If the bit value is set to 0, then the high pulse will be transmitted/received. If the bit value is set to 1, then no energy will be transmitted/received.

Bit 6: **SMP\_M - Sampling mode.**

To choose receiver sampling mode.

Write to 0 causes T-period sampling to be used, so that the T-period is programmed UART baud rate.

Write to 1 causes direct use of programmed baud rate to do over-sampling.

Bit 5: **RXCFS - Receiver Carry Frequency Select**

RXCFS	Selected Frequency
0	30K ~ 56K Hz
1	400K ~ 480K Hz

Bit 4: **Reserved, write 0.**

Bit 3: **TX\_CFS - Transmitter Carry Frequency Select.**

Sets low speed or high speed transmitter carry frequency.

TX_CFS	Selected Frequency
0	30K ~ 56K Hz
1	400K ~ 480K Hz

Bit 2: **RX\_DM - Receiver Demodulation mode.**

RX_DM	Demodulation Mode
0	Enables internal decoder
1	Disables internal decoder

Bit 1~0: **TX\_MM1~0 - Transmitter Modulation mode 1~0**

TX_MM1~0	TX Modulation Mode
00	Continuously sends pulse for logic 0
01	<b>8 pulses</b> for logic 0 and no pulse for logic 1.
10	<b>6 pulses</b> for logic 0 and no pulse for logic 1
11	Reserved.

#### 4.3.9.3 Set7.Reg3 - Sets Select Register (SSR)

Reg.	Bit 7	Bit 6	Bit 5	Bit 4	Bit 3	Bit 2	Bit 1	Bit 0
SSR	Bit 7	Bit 6	Bit 5	Bit 4	Bit 3	Bit 2	Bit 1	Bit 0
default Value	1	1	1	1	0	1	0	0

Reading this register returns F4<sub>16</sub>. A write to this register causes switch to other Set.

#### 4.3.9.4 Set7.Reg4 - Infrared Module (Front End) Select 1 (IRM\_SL1)

Reg.	Bit 7	Bit 6	Bit 5	Bit 4	Bit 3	Bit 2	Bit 1	Bit 0
IRM_SL1	IR_MSP	SIR_SL2	SIR_SL1	SIR_SL0	-	AIR_SL2	AIR_SL1	AIR_SL0
default Value	0	0	0	0	0	0	0	0

**Bit 7: IR\_MSP - IR mode Select Pulse**

Write to 1 causes the transmitter (IRTX) to send a 64 ns pulse to setup a special IR front-end operational mode. When IR front-end module uses *mode select pin (MD)* and *transmitter IR pulse (IRTX)* to switch high speed IR (such as FIR or MIR) or low speed IR (SIR or ASK-IR), this bit should be used.

**Bit 6~4: SIR\_SL2~0 - SIR (Serial IR) mode select.**

These bits are to program the operational mode of the SIR front-end module. These values of SIR\_SL2~0 will automatically load to pins of IR\_SL2~0, respectively, when (1) AM\_FMT=1 (Automatic Format, in Set7.Reg7.Bit7), (2) the mode of Advanced UART is set to SIR (AD\_MD2~0, in Set0.Reg4.Bit7~0).

Bit 3: **Reserved**, write 0.

**Bit 2~0: AIR\_SL2~0 - ASK-IR mode Select.**

These bits will setup the operational mode of ASK-IR front-end module when AM\_FMT=1 and AD\_MD2~0 are set to ASK-IR mode. These values will automatically load to IR\_SL2~0, respectively.

**4.3.9.5 Set7.Reg5 - Infrared module (Front End) Select 2 (IRM\_SL2)**

Reg.	Bit 7	Bit 6	Bit 5	Bit 4	Bit 3	Bit 2	Bit 1	Bit 0
IRM_SL2	-	FIR_SL2	FIR_SL1	FIR_SL0	-	MIR_SL2	MIR_SL1	MIR_SL0
default Value	0	0	0	0	0	0	0	0

Bit 7: **Reserved**, write 0.

**Bit 6~4: FIR\_SL2~0 - FIR mode select.**

These bits setup the operational mode of FIR front-end module when AM\_FMT=1 and AD\_MD2~0 set to FIR mode. These values will automatically load to IR\_SL2~0, respectively.

Bit 3: **Reserved**, write 0.

**Bit 2~0: MIR\_SL2~0 - MIR mode Select.**

These bits setup the MIR operational mode when AM\_FMT=1 and AD\_MD2~0 set to MIR mode. These values will be automatically loaded to IR\_SL2~0, respectively.

**4.3.9.6 Set7.Reg6 - Infrared module (Front End) Select 3 (IRM\_SL3)**

Reg.	Bit 7	Bit 6	Bit 5	Bit 4	Bit 3	Bit 2	Bit 1	Bit 0
IRM_SL3	-	LRC_SL2	LRC_SL1	LRC_SL0	-	HRC_SL2	HRC_SL1	HRC_SL0
default Value	0	0	0	0	0	0	0	0

Bit 7: **Reserved**, write 0.

Bit 6~4: **LRC\_SL2~0 - Low Speed Remote IR mode select.**

These bits setup the operational mode of *low speed* remote IR front-end module when AM\_FMT=1 and AD\_MD2~0 set to Remote IR mode. These values will automatically load to IR\_SL2~0, respectively.

Bit 3: **Reserved**, write 0.

Bit 2~0: **HRC\_SL2~0 - High Speed Remote IR Mode Select.**

These bits setup the operational mode of *high speed* remote IR front-end module when AM\_FMT=1 and .AD\_MD2~0 set to Remote IR mode. These values will automatically load to IR\_SL2~0, respectively.

#### 4.3.9.7 Set7.Reg7 - Infrared module Control Register (IRM\_CR)

Reg.	Bit 7	Bit 6	Bit 5	Bit 4	Bit 3	Bit 2	Bit 1	Bit 0
IRM_CR	AM_FMT	IRX_MSL	IRSL0D	RXINV	TXINV	-	-	-
default Value	0	0	0	0	0	0	0	0

Bit 7: **AM\_FMT - Automatic Format**

Write to 1 enables automatic format IR front-end module. This bit will affect the output of IR\_SL2~0, which is referred by IR front-end module selection (Set7.Reg4~6)

Bit 6: **IRX\_MSL - IR Receiver module Select**

Select the receiver input path from the IR front end module if IR module has a separated high speed and low speed receiver path. If the IR module has only one receiving path, then this bit should be set to 0.

IRX_MSL	Receiver Pin selected
0	IRRX (Low/High Speed)
1	IRRXH (High Speed)

Bit 5: **IRSL0D - Direction of IRSL0 Pin**

Select function for IRRXH or IRSL0 because they share a common pin with different input/output direction.

IRSL0_D	Function
0	IRRXH (I/P)
1	IRSL0 (O/P)

Table: IR receiver input pin selection

IRSL0D	IRX_MSL	AUX_RX	High Speed IR	Selected IR Pin
0	0	0	X	<b>IRRX</b>
0	0	1	X	<b>IRRXH</b>
0	1	X	0	<b>IRRX</b>
0	1	X	1	<b>IRRXH</b>
1	0	0	X	<b>IRRX</b>
1	0	1	X	Reserved
1	1	X	0	<b>IRRX</b>
1	1	X	1	Reserved

Note that (1) AUX\_RX is defined in Set5.Reg4.Bit4, (2) high speed IR includes MIR (1.152M or 0.576M bps) and FIR (4M bps), (3) IRRX is the input of the low speed or high speed IR receiver, IRRXH is the input of the high speed IR receiver.

Bit 4:       **RXINV - Receiving Signal Invert**

Write to 1 inverts the receiving signal.

Bit 3:       **TXINV - Transmitting Signal Invert**

Write to 1 inverts the transmitting signal.

Bit 2~0:     **Reserved**, write 0.

## 4.0 PARALLEL PORT

### 4.1 Printer Interface Logic

The parallel port of the W83877ATF makes possible the attachment of various devices that accept eight bits of parallel data at standard TTL level. The W83877ATF supports an IBM XT/AT compatible parallel port (SPP), bi-directional parallel port (BPP), Enhanced Parallel Port (EPP), Extended Capabilities Parallel Port (ECP), Extension FDD mode (EXTFDD), and Extension 2FDD mode (EXT2FDD) on the parallel port. Refer to the configuration registers for more information on disabling, power-down, and on selecting the mode of operation.

Table 4-1 shows the pin definitions for different modes of the parallel port.

**TABLE 4-1-A Parallel Port Connector and Pin Definition for SPP/EPP/ECP Modes**

HOST CONNECTOR	PIN NUMBER OF W83877ATF	PIN ATTRIBUTE	SPP	EPP	ECP
1	19	O	nSTB	nWrite	nSTB, HostClk
2-9	9-14,16-17	I/O	PD<0:7>	PD<0:7>	PD<0:7>
10	26	I	nACK	Intr	nACK, PeriphClk
11	24	I	BUSY	nWait	BUSY, PeriphAck <sup>2</sup>
12	27	I	PE	PE	PEerror, nAckReverse <sup>2</sup>
13	28	I	SLCT	Select	SLCT, Xflag
14	20	O	nAFD	nDStrb	nAFD, HostAck <sup>2</sup>
15	29	I	nERR	nError	nFault <sup>1</sup> , nPeriphRequest <sup>2</sup>
16	21	O	nINIT	nInit	nINIT <sup>1</sup> , nReverseRqst <sup>2</sup>
17	22	O	nSLIN	nAStrb	nSLIN <sup>1</sup> , ECPMode <sup>2</sup>

Notes:

n<name > : Active Low

1. Compatible Mode
2. High Speed Mode
3. For more information, refer to the IEEE 1284 standard.

**TABLE 4-1-B Parallel Port Connector and Pin Definition for EXTFDD and EXT2FDD Modes**

HOST CONNECTOR	PIN NUMBER OF W83877ATF	PIN ATTRIBUTE	SPP	PIN ATTRIBUTE	EXT2FDD	PIN ATTRIBUTE	EXTFDD
1	19	O	nSTB	---	---	---	---
2	9	I/O	PD0	I	$\overline{\text{INDEX2}}$	I	$\overline{\text{INDEX2}}$
3	10	I/O	PD1	I	$\overline{\text{TRAK02}}$	I	
4	11	I/O	PD2	I	$\overline{\text{WP2}}$	I	
5	12	I/O	PD3	I	$\overline{\text{RDATA2}}$	I	$\overline{\text{RDATA2}}$
6	13	I/O	PD4	I	$\overline{\text{DSKCHG2}}$	I	$\overline{\text{DSKCHG2}}$
7	14	I/O	PD5	---	---	---	---
8	15	I/O	PD6	OD	$\overline{\text{MOA2}}$	---	---
9	16	I/O	PD7	OD	$\overline{\text{DSA2}}$	---	---
10	26	I	nACK	OD	$\overline{\text{DSB2}}$	OD	
11	24	I	BUSY	OD	$\overline{\text{MOB2}}$	OD	
12	27	I	PE	OD	$\overline{\text{WD2}}$	OD	$\overline{\text{WD2}}$
13	28	I	SLCT	OD	$\overline{\text{WE2}}$	OD	$\overline{\text{WE2}}$
14	20	O	nAFD	OD	$\overline{\text{RWC2}}$	OD	$\overline{\text{RWC2}}$
15	29	I	nERR	OD	$\overline{\text{NERR2}}$	OD	
16	21	O	nINIT	OD	$\overline{\text{DIR2}}$	OD	$\overline{\text{DIR2}}$
17	22	O	nSLIN	OD	$\overline{\text{STEP2}}$	OD	

## 4.2 Enhanced Parallel Port (EPP)

TABLE 4-2 PRINTER MODE AND EPP REGISTER ADDRESS

A2	A1	A0	REGISTER	NOTE
0	0	0	Data port (R/W)	1
0	0	1	Printer status buffer (Read)	1
0	1	0	Printer control latch (Write)	1
0	1	0	Printer control swapper (Read)	1
0	1	1	EPP address port (R/W)	2
1	0	0	EPP data port 0 (R/W)	2
1	0	1	EPP data port 1 (R/W)	2
1	1	0	EPP data port 2 (R/W)	2
1	1	1	EPP data port 2 (R/W)	2

Notes:

1. These registers are available in all modes.
2. These registers are available only in EPP mode.

### 4.2.1 Data Swapper

The system microprocessor can read the contents of the printer's data latch by reading the data swapper.

### 4.2.2 Printer Status Buffer

The system microprocessor can read the printer status by reading the address of the printer status buffer. The bit definitions are as follows:

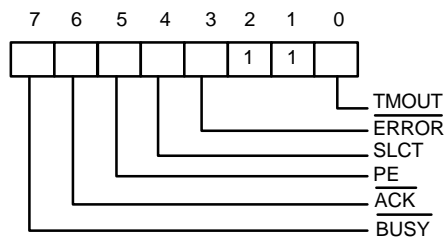

Bit 7: This signal is active during data entry, when the printer is off-line during printing, when the print head is changing position, or during an error state. When this signal is active, the printer is busy and cannot accept data.

Bit 6: This bit represents the current state of the printer's  $\overline{\text{ACK}}$  signal. A 0 means the printer has received a character and is ready to accept another. Normally, this signal will be active for approximately 5 microseconds before  $\overline{\text{BUSY}}$  stops.

Bit 5: A 1 means the printer has detected the end of paper.

Bit 4: A 1 means the printer is selected.

Bit 3: A 0 means the printer has encountered an error condition.

Bit 1, 2: These two bits are not implemented and are logic one during a read of the status register.

Bit 0: This bit is valid in EPP mode only. It indicates that a 10  $\mu$ S time-out has occurred on the EPP bus. A logic 0 means that no time-out error has occurred; a logic 1 means that a time-out error has been detected. Writing a logic 1 to this bit will clear the time-out status bit; writing a logic 0 has no effect.

### 4.2.3 Printer Control Latch and Printer Control Swapper

The system microprocessor can read the contents of the printer control latch by reading the printer control swapper. Bit definitions are as follows:

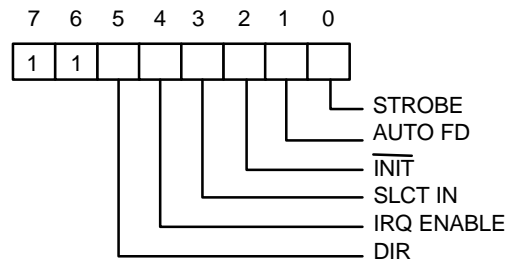

Bit 7, 6: These two bits are a logic one during a read. They can be written.

Bit 5: Direction control bit

When this bit is a logic 1, the parallel port is in input mode (read); when it is a logic 0, the parallel port is in output mode (write). This bit can be read and written. In SPP mode, this bit is invalid and fixed at zero.

Bit 4: A 1 in this position allows an interrupt to occur when  $\overline{\text{ACK}}$  changes from low to high.

Bit 3: A 1 in this bit position selects the printer.

Bit 2: A 0 starts the printer (50 microsecond pulse, minimum).

Bit 1: A 1 causes the printer to line-feed after a line is printed.

Bit 0: A 0.5 microsecond minimum high active pulse clocks data into the printer. Valid data must be present for a minimum of 0.5 microseconds before and after the strobe pulse.

#### 4.2.4 EPP Address Port

The address port is available only in EPP mode. Bit definitions are as follows:

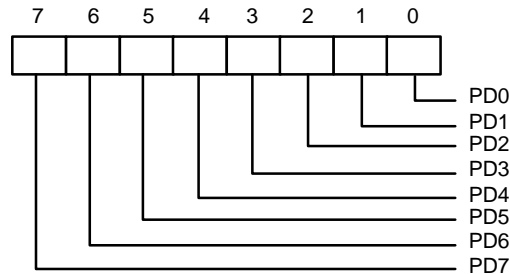

The contents of DB0-DB7 are buffered (non-inverting) and output to ports PD0-PD7 during a write operation. The leading edge of  $\overline{IOW}$  causes an EPP address write cycle to be performed, and the trailing edge of  $\overline{IOW}$  latches the data for the duration of the EPP write cycle.

PD0-PD7 ports are read during a read operation. The leading edge of  $\overline{IOR}$  causes an EPP address read cycle to be performed and the data to be output to the host CPU.

#### 4.2.5 EPP Data Port 0-3

These four registers are available only in EPP mode. Bit definitions of each data port are as follows:

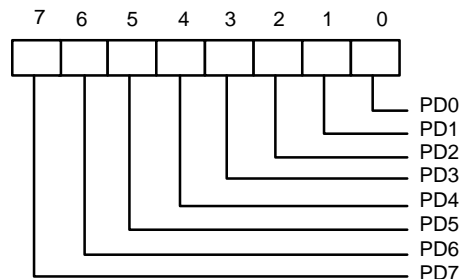

When accesses are made to any EPP data port, the contents of DB0-DB7 are buffered (non-inverting) and output to the ports PD0-PD7 during a write operation. The leading edge of  $\overline{IOW}$  causes an EPP data write cycle to be performed, and the trailing edge of  $\overline{IOW}$  latches the data for the duration of the EPP write cycle.

During a read operation, ports PD0-PD7 are read, and the leading edge of  $\overline{IOR}$  causes an EPP read cycle to be performed and the data to be output to the host CPU.

**4.2.6 Bit Map of Parallel Port and EPP Registers**

REGISTER	7	6	5	4	3	2	1	0
Data Port (R/W)	PD7	PD6	PD5	PD4	PD3	PD2	PD1	PD0
Status Buffer (Read)	$\overline{\text{BUSY}}$	$\overline{\text{ACK}}$	PE	SLCT	$\overline{\text{ERROR}}$	1	1	TMOUT
Control Swapper (Read)	1	1	1	IRQEN	SLIN	$\overline{\text{INIT}}$	$\overline{\text{AUTOFD}}$	$\overline{\text{STROBE}}$
Control Latch (Write)	1	1	DIR	IRQ	SLIN	$\overline{\text{INIT}}$	$\overline{\text{AUTOFD}}$	$\overline{\text{STROBE}}$
EPP Address Port (R/W)	PD7	PD6	PD5	PD4	PD3	PD2	PD1	PD0
EPP Data Port 0 (R/W)	PD7	PD6	PD5	PD4	PD3	PD2	PD1	PD0
EPP Data Port 1 (R/W)	PD7	PD6	PD5	PD4	PD3	PD2	PD1	PD0
EPP Data Port 2 (R/W)	PD7	PD6	PD5	PD4	PD3	PD2	PD1	PD0
EPP Data Port 3 (R/W)	PD7	PD6	PD5	PD4	PD3	PD2	PD1	PD0

**4.2.7 EPP Pin Descriptions**

EPP NAME	TYPE	EPP DESCRIPTION
nWrite	O	Denotes an address or data read or write operation.
PD<0:7>	I/O	Bi-directional EPP address and data bus.
Intr	I	Used by peripheral device to interrupt the host.
nWait	I	Inactive to acknowledge that data transfer is completed. Active to indicate that the device is ready for the next transfer.
PE	I	Paper end; same as SPP mode.
Select	I	Printer selected status; same as SPP mode.
nDStrb	O	This signal is active low. It denotes a data read or write operation.
nError	I	Error; same as SPP mode.
nInits	O	This signal is active low. When it is active, the EPP device is reset to its initial operating mode.
nAStrb	O	This signal is active low. It denotes an address read or write operation.

**4.2.8 EPP Operation**

When the EPP mode is selected in the configuration register, the standard and bi-directional modes are also available. The PDx bus is in the standard or bi-directional mode when no EPP read, write, or address cycle is currently being executed. In this condition all output signals are set by the SPP Control Port and the direction is controlled by DIR of the Control Port.

A watchdog timer is required to prevent system lockup. The timer indicates that more than 10  $\mu\text{S}$  have elapsed from the start of the EPP cycle to the time  $\overline{\text{WAIT}}$  is de-asserted. The current EPP cycle is aborted when a time-out occurs. The time-out condition is indicated in Status bit 0.

### EPP Operation

The EPP operates on a two-phase cycle. First, the host selects the register within the device for subsequent operations. Second, the host performs a series of read and/or write byte operations to the selected register. Four operations are supported on the EPP: Address Write, Data Write, Address Read, and Data Read. All operations on the EPP device are performed asynchronously.

### EPP Version 1.9 Operation

The EPP read/write operation can be completed under the following conditions:

- a. If the nWait is active low, when the read cycle (nWrite inactive high, nDStrb/nAStsb active low) or write cycle (nWrite active low, nDStrb/nAStsb active low) starts, the read/write cycle proceeds normally and will be completed when nWait goes inactive high.
- b. If nWait is inactive high, the read/write cycle will not start. It must wait until nWait changes to active low, at which time it will start as described above.

### EPP Version 1.7 Operation

The EPP read/write cycle can start without checking whether nWait is active or inactive. Once the read/write cycle starts, however, it will not terminate until nWait changes from active low to inactive high.

## **4.3 Extended Capabilities Parallel (ECP) Port**

This port is software and hardware compatible with existing parallel ports, so it may be used in a standard printer mode if ECP is not required. It provides an automatic high burst-bandwidth channel that supports DMA for ECP in both the forward (host to peripheral) and reverse (peripheral to host) directions.

Small FIFOs are used in both forward and reverse directions to improve the maximum bandwidth requirement. The size of the FIFO is 16 bytes. The ECP port supports an automatic handshake for the standard parallel port to improve compatibility mode transfer speed.

The ECP port supports run-length-encoded (RLE) decompression (required) in the hardware. Compression is accomplished by counting identical bytes and transmitting an RLE byte that indicates how many times the next byte is to be repeated. The hardware support for compression is optional.

For more information about the ECP Protocol, refer to the Extended Capabilities Port Protocol and ISA Interface Standard.

**4.3.1 ECP Register and Mode Definitions**

NAME	ADDRESS	I/O	ECP MODES	FUNCTION
data	Base+000h	R/W	000-001	Data Register
ecpAFifo	Base+000h	R/W	011	ECP FIFO (Address)
dsr	Base+001h	R	All	Status Register
dcr	Base+002h	R/W	All	Control Register
cFifo	Base+400h	R/W	010	Parallel Port Data FIFO
ecpDFifo	Base+400h	R/W	011	ECP FIFO (DATA)
tFifo	Base+400h	R/W	110	Test FIFO
cnfgA	Base+400h	R	111	Configuration Register A
cnfgB	Base+401h	R/W	111	Configuration Register B
ecr	Base+402h	R/W	All	Extended Control Register

Note: The base addresses are specified by CR23, which are determined by configuration register or hardware setting.

MODE	DESCRIPTION
000	SPP mode
001	PS/2 Parallel Port mode
010	Parallel Port Data FIFO mode
011	ECP Parallel Port mode
100	EPP mode (If this option is enabled in the CR9 and CR0 to select ECP/EPP mode)
101	Reserved
110	Test mode
111	Configuration mode

Note: The mode selection bits are bit 7-5 of the Extended Control Register.

**4.3.2 Data and ecpAFifo Port**

Modes 000 (SPP) and 001 (PS/2) (Data Port)

During a write operation, the Data Register latches the contents of the data bus on the rising edge of the input. The contents of this register are output to the PD0-PD7 ports. During a read operation, ports PD0-PD7 are read and output to the host. The bit definitions are as follows:

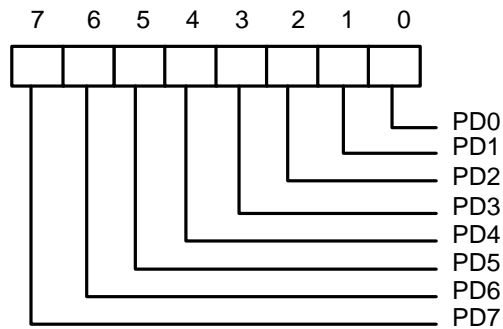

Mode 011 (ECP FIFO-Address/RLE)

A data byte written to this address is placed in the FIFO and tagged as an ECP Address/RLE. The hardware at the ECP port transmits this byte to the peripheral automatically. The operation of this register is defined only for the forward direction. The bit definitions are as follows:

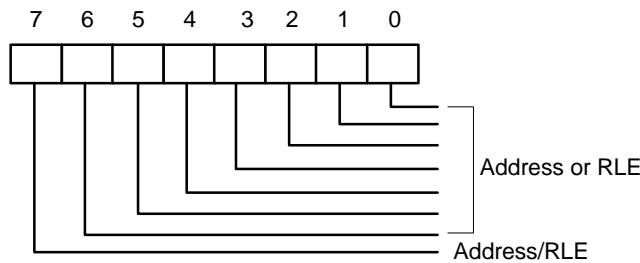

4.3.3 Device Status Register (DSR)

These bits are at low level during a read of the Printer Status Register. The bits of this status register are defined as follows:

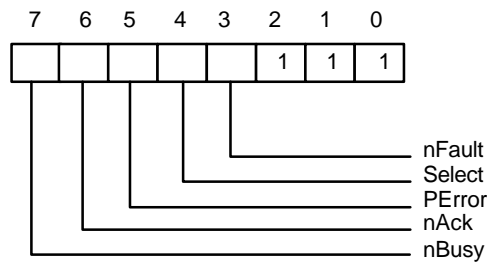

Bit 7: This bit reflects the complement of the Busy input.

Bit 6: This bit reflects the nAck input.

Bit 5: This bit reflects the PError input.

Bit 4: This bit reflects the Select input.

Bit 3: This bit reflects the nFault input.

Bit 2-0: These three bits are not implemented and are always logic one during a read.

#### 4.3.4 Device Control Register (DCR)

The bit definitions are as follows:

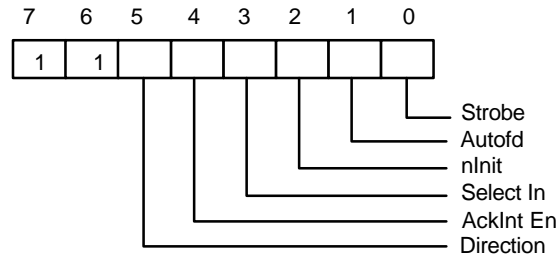

Bit 6, 7: These two bits are logic one during a read and cannot be written.

Bit 5: This bit has no effect and the direction is always out if mode = 000 or mode = 010. Direction is valid in all other modes.

0 the parallel port is in output mode.

1 the parallel port is in input mode.

Bit 4: Interrupt request enable. When this bit is set to a high level, it may be used to enable interrupt requests from the parallel port to the CPU due to a low to high transition on the  $\overline{ACK}$  input.

Bit 3: This bit is inverted and output to the  $\overline{SLIN}$  output.

0 The printer is not selected.

1 The printer is selected.

Bit 2: This bit is output to the  $\overline{INIT}$  output.

Bit 1: This bit is inverted and output to the  $\overline{AFD}$  output.

Bit 0: This bit is inverted and output to the  $\overline{STB}$  output.

#### 4.3.5 cFifo (Parallel Port Data FIFO) Mode = 010

This mode is defined only for the forward direction. The standard parallel port protocol is used by a hardware handshake to the peripheral to transmit bytes written or DMAed from the system to this FIFO. Transfers to the FIFO are byte aligned.

#### 4.3.6 ecpDFifo (ECP Data FIFO) Mode = 011

When the direction bit is 0, bytes written or DMAed from the system to this FIFO are transmitted by a hardware handshake to the peripheral using the ECP parallel port protocol. Transfers to the FIFO are byte aligned.

When the direction bit is 1, data bytes from the peripheral are read under automatic hardware handshake from ECP into this FIFO. Reads or DMA's from the FIFO will return bytes of ECP data to the system.

**4.3.7 tFifo (Test FIFO Mode) Mode = 110**

Data bytes may be read, written, or DMAed to or from the system to this FIFO in any direction.

Data in the tFIFO will not be transmitted to the parallel port lines. However, data in the tFIFO may be displayed on the parallel port data lines.

**4.3.8 cnfgA (Configuration Register A) Mode = 111**

This register is a read-only register. When it is read, 10H is returned. This indicates to the system that this is an 8-bit implementation.

**4.3.9 cnfgB (Configuration Register B) Mode = 111**

The bit definitions are as follows:

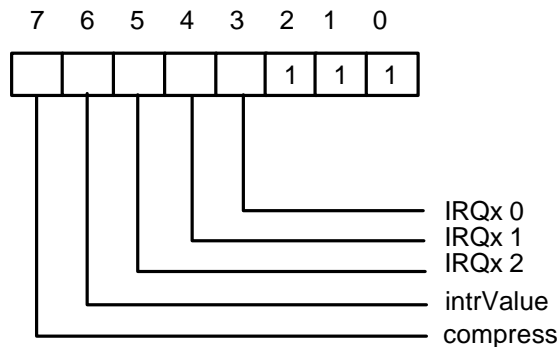

Bit 7: This bit is read-only. It is at low level during a read. This means that this chip does not support hardware RLE compression.

Bit 6: Returns the value on the ISA IRQ line to determine possible conflicts.

Bit 5-3: Reflect the IRQ resource assigned for ECP port.

cnfgB[5:3]	IRQ resource
000	reflect other IRQ resources selected by PnP register (default)
001	IRQ7
010	IRQ9
011	IRQ10
100	IRQ11
101	IRQ14
110	IRQ15
111	IRQ5

Bit 2-0: These five bits are at high level during a read and can be written.

#### 4.3.10 ecr (Extended Control Register) Mode = all

This register controls the extended ECP parallel port functions. The bit definitions are follows:

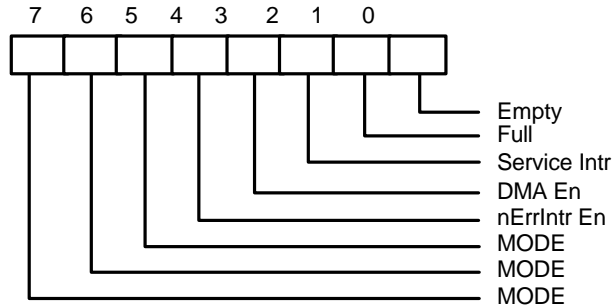

Bit 7-5: These bits are read/write and select the mode.

- 000 Standard Parallel Port mode. The FIFO is reset in this mode.
- 001 PS/2 Parallel Port mode. This is the same as 000 except that direction may be used to tri-state the data lines, and reading the data register returns the value on the data lines and not the value in the data register.
- 010 Parallel Port FIFO mode. This is the same as 000 except that bytes are written or DMAed to the FIFO. FIFO data are automatically transmitted using the standard parallel port protocol. This mode is useful only when direction is 0.
- 011 ECP Parallel Port Mode. When the direction is 0 (forward direction), bytes placed into the ecpDFifo and bytes written to the ecpAFifo are placed in a single FIFO and transmitted automatically to the peripheral using ECP Protocol. When the direction is 1 (reverse direction) bytes are moved from the ECP parallel port and packed into bytes in the ecpDFifo.
- 100 Selects EPP Mode. In this mode, EPP is active if the EPP supported option is selected.
- 101 Reserved.
- 110 Test Mode. The FIFO may be written and read in this mode, but the data will not be transmitted on the parallel port.
- 111 Configuration Mode. The configA and configB registers are accessible at 0x400 and 0x401 in this mode.

Bit 4: Read/Write (Valid only in ECP Mode)

- 1 Disables the interrupt generated on the asserting edge of nFault.
- 0 Enables an interrupt pulse on the high to low edge of nFault. If nFault is asserted (interrupt) an interrupt will be generated and this bit is written from a 1 to 0.

Bit 3: Read/Write

- 1 Enables DMA.
- 0 Disables DMA unconditionally.

**Bit 2: Read/Write**

- 1 Disables DMA and all of the service interrupts.
- 0 Enables one of the following cases of interrupts. When one of the service interrupts has occurred, the serviceIntr bit is set to a 1 by hardware. This bit must be reset to 0 to re-enable the interrupts. Writing a 1 to this bit will not cause an interrupt.
  - (a) dmaEn = 1:  
During DMA this bit is set to a 1 when terminal count is reached.
  - (b) dmaEn = 0 direction = 0:  
This bit is set to 1 whenever there are writeIntr Threshold or more bytes free in the FIFO.
  - (c) dmaEn = 0 direction = 1:  
This bit is set to 1 whenever there are readIntr Threshold or more valid bytes to be read from the FIFO.

**Bit 1: Read only**

- 0 The FIFO has at least 1 free byte.
- 1 The FIFO cannot accept another byte or the FIFO is completely full.

**Bit 0: Read only**

- 0 The FIFO contains at least 1 byte of data.
- 1 The FIFO is completely empty.

**4.3.11 Bit Map of ECP Port Registers**

	D7	D6	D5	D4	D3	D2	D1	D0	NOTE
data	PD7	PD6	PD5	PD4	PD3	PD2	PD1	PD0	
ecpAFifo	Addr/RLE	Address or RLE field							2
dsr	nBusy	nAck	PError	Select	nFault	1	1	1	1
dcr	1	1	Directio	ackIntEn	SelectIn	nIntr	autofd	strobe	1
cFifo	Parallel Port Data FIFO								2
ecpDFifo	ECP Data FIFO								2
tFifo	Test FIFO								2
cnfgA	0	0	0	1	0	0	0	0	
cnfgB	compress	intrValue	1	1	1	1	1	1	
ecr	MODE			nErrIntrEn	dmaEn	serviceIntr	full	empty	

**Notes:**

1. These registers are available in all modes.
2. All FIFOs use one common 16-byte FIFO.

**4.3.12 ECP Pin Descriptions**

<b>NAME</b>	<b>TYPE</b>	<b>DESCRIPTION</b>
nStrobe (HostClk)	O	The nStrobe registers data or address into the slave on the asserting edge during write operations. This signal handshakes with Busy.
PD<7:0>	I/O	These signals contains address or data or RLE data.
nAck (PeriphClk)	I	This signal indicates valid data driven by the peripheral when asserted. This signal handshakes with nAutofd in reverse.
Busy (PeriphAck)	I	This signal deasserts to indicate that the peripheral can accept data. It indicates whether the data lines contain ECP command information or data in the reverse direction. When in reverse direction, normal data are transferred when Busy (PeriphAck) is high and an 8-bit command is transferred when it is low.
PError (nAckReverse)	I	This signal is used to acknowledge a change in the direction of the transfer (asserted = forward). The peripheral drives this signal low to acknowledge nReverseRequest. The host relies upon nAckReverse to determine when it is permitted to drive the data bus.
Select (Xflag)	I	Indicates printer on line.
nAutoFd (HostAck)	O	Requests a byte of data from the peripheral when it is asserted. This signal indicates whether the data lines contain ECP address or data in the forward direction. When in forward direction, normal data are transferred when nAutoFd (HostAck) is high and an 8-bit command is transferred when it is low.
nFault (nPeriphRequest)	I	Generates an error interrupt when it is asserted. This signal is valid only in the forward direction. The peripheral is permitted (but not required) to drive this pin low to request a reverse transfer during ECP Mode.
nInit (nReverseRequest)	O	This signal sets the transfer direction (asserted = reverse, deasserted = forward). This pin is driven low to place the channel in the reverse direction.
nSelectIn (ECPMode)	O	This signal is always deasserted in ECP mode.

### 4.3.13 ECP Operation

The host must negotiate on the parallel port to determine if the peripheral supports the ECP protocol before ECP operation. After negotiation, it is necessary to initialize some of the port bits. The following are required:

- (a) Set direction = 0, enabling the drivers.
- (b) Set strobe = 0, causing the nStrobe signal to default to the deasserted state.
- (c) Set autoFd = 0, causing the nAutoFd signal to default to the deasserted state.
- (d) Set mode = 011 (ECP Mode)

ECP address/RLE bytes or data bytes may be sent automatically by writing the ecpAFifo or ecpDFifo, respectively.

#### Mode Switching

Software will execute P1284 negotiation and all operation prior to a data transfer phase under programmed I/O control (mode 000 or 001). Hardware provides an automatic control line handshake, moving data between the FIFO and the ECP port only in the data transfer phase (mode 011 or 010).

If the port is in mode 000 or 001, it may switch to any other mode. If the port is not in mode 000 or 001, it can only be switched into mode 000 or 001. The direction can be changed only in mode 001.

When in extended forward mode, the software should wait for the FIFO to be empty before switching back to mode 000 or 001. In ECP reverse mode the software waits for all the data to be read from the FIFO before changing back to mode 000 or 001.

#### Command/Data

ECP mode allows the transfer of normal 8-bit data or 8-bit commands. In the forward direction, normal data are transferred when HostAck is high and an 8-bit command is transferred when HostAck is low. The most significant bits of the command indicate whether it is a run-length count (for compression) or a channel address.

In the reverse direction, normal data are transferred when PeriphAck is high and an 8-bit command is transferred when PeriphAck is low. The most significant bit of the command is always zero.

#### Data Compression

The W83877ATF supports run length encoded (RLE) decompression in hardware and can transfer compressed data to a peripheral. Note that odd (RLE) compression in hardware is not supported. In order to transfer data in ECP mode, the compression count is written to the ecpAFifo and the data byte is written to the ecpDFifo.

### 4.3.14 FIFO Operation

The FIFO threshold is set in configuration register 5. All data transfers to or from the parallel port can proceed in DMA or Programmed I/O (non-DMA) mode, as indicated by the selected mode. The FIFO is used by selecting the Parallel Port FIFO mode or ECP Parallel Port Mode. After a reset, the FIFO is disabled.

#### 4.3.15 DMA Transfers

DMA transfers are always to or from the ecpDFifo, tFifo, or CFifo. The DMA uses the standard PC DMA services. The ECP requests DMA transfers from the host by activating the PDRQ pin. The DMA will empty or fill the FIFO using the appropriate direction and mode. When the terminal count in the DMA controller is reached, an interrupt is generated and serviceIntr is asserted, which will disable the DMA.

#### 4.3.16 Programmed I/O (NON-DMA) Mode

The ECP or parallel port FIFOs can also be operated using interrupt driven programmed I/O. Programmed I/O transfers are to the ecpDFifo at 400H and ecpAFifo at 000H, or from the ecpDFifo located at 400H, or to/from the tFifo at 400H. The host must set the direction, state, dmaEn = 0 and serviceIntr = 0 in the programmed I/O transfers.

The ECP requests programmed I/O transfers from the host by activating the IRQ pin. The programmed I/O will empty or fill the FIFO using the appropriate direction and mode.

### 4.4 Extension FDD Mode (EXTFDD)

In this mode, the W83877ATF changes the printer interface pins to FDC input/output pins, allowing the user to install a second floppy disk drive (FDD B) through the DB-25 printer connector. The pin assignments for the FDC input/output pins are shown in Table 5-1.

After the printer interface is set to EXTFDD mode, the following occur:

- (1) Pins  $\overline{\text{MOB}}$  and  $\overline{\text{DSB}}$  will be forced to inactive state.
- (2) Pins  $\overline{\text{DSKCHG}}$ ,  $\overline{\text{RDATA}}$ ,  $\overline{\text{WP}}$ ,  $\overline{\text{TRAK0}}$ ,  $\overline{\text{INDEX}}$  will be logically ORed with pins PD4-PD0 to serve as input signals to the FDC.
- (3) Pins PD4-PD0 each will have an internal resistor of about 1K ohm to serve as pull-up resistor for FDD open drain/collector output.
- (4) If the parallel port is set to EXTFDD mode after the system has booted DOS or another operating system, a warm reset is needed to enable the system to recognize the extension floppy drive.

### 4.5 Extension 2FDD Mode (EXT2FDD)

In this mode, the W83877ATF changes the printer interface pins to FDC input/output pins, allowing the user to install two external floppy disk drives through the DB-25 printer connector to replace internal floppy disk drives A and B. The pin assignments for the FDC input/output pins are shown in Table 5-1.

After the printer interface is set to EXTFDD mode, the following occur:

- (1) Pins  $\overline{\text{MOA}}$ ,  $\overline{\text{DSA}}$ ,  $\overline{\text{MOB}}$ , and  $\overline{\text{DSB}}$  will be forced to inactive state.
- (2) Pins  $\overline{\text{DSKCHG}}$ ,  $\overline{\text{RDATA}}$ ,  $\overline{\text{WP}}$ ,  $\overline{\text{TRAK0}}$ , and  $\overline{\text{INDEX}}$  will be logically ORed with pins PD4-PD0 to serve as input signals to the FDC.
- (3) Pins PD4-PD0 each will have an internal resistor of about 1K ohm to serve as pull-up resistor for FDD open drain/collector output.
- (4) If the parallel port is set to EXT2FDD mode after the system has booted DOS or another operating system, a warm reset is needed to enable the system to recognize the extension floppy drive.

## 5.0 PLUG AND PLAY CONFIGURATION

A powerful new plug-and-play function has been built into the W83877ATF to help simplify the task of setting up a computer environment. With appropriate support from BIOS manufacturers, the system designer can freely allocate Winbond I/O devices (i.e., the FDC, PRT and UART ) in the PC's I/O space (100H - 3FFH). In addition, the W83877ATF also provides 8 interrupt requests and 3 DMA pairs for designers to assign in interfacing FDCs, UARTs, and PRTs. Hence this powerful I/O chip offers greater flexibility for system designers.

The PnP feature is implemented through a set of Extended Function Registers (CR20 to 29). Details on configuring these registers are given in Section 8. The default values of these PnP-related registers set the system to a configuration compatible with environments designed with previous Winbond I/O chips.

## 6.0 ACPI /LEGACY FEATURE AND AUTO POWER MANAGEMENT

### 6.1 ACPI/Legacy power management

W83877ATF supports both ACPI and legacy power management models. For the ACPI power management, the  $\overline{\text{SCI}}$  pin is dedicated to the SCI interrupt signal for the SCI interrupt handler; For the legacy power management, the  $\overline{\text{SMI}}$  pin is dedicated to the SMI interrupt signal for the SMI interrupt handler.

Two register blocks are used for the ACPI/Legacy power management. They are the PM1 and GPE register blocks. Their base addresses are held in the W83877ATF configuration registers CR33 and CR34 respectively. Configuration registers CR40 to CR45 are for the legacy power management. The above configuration registers hold the interrupt event enable and status bits of the SMI interrupts. Control over the routing of SCI and SMI interrupts to the output pins is also contained in the above registers.

One 24-bit power management timer is also implemented. It provides an accurate time value used by the system software to measure and profile system idleness.

### 6.2 Device(auto) power management

W83877ATF also provides the auto power management function for each device within it. They are the printer port, FDC, UART A, and UART B devices in W83877ATF respectively. Device idle and trap status are provided to indicate the device's working/sleeping state. Device idle timer with programmable initial value is provided for each device, which enters the powerdown state when the powerdown conditions are met. Any access to certain registers and external event input will wake up the devices. The global stand-by timer deals with the other logic part excluding the printer port, FDC, UART A , and UART B devices. The global stand-by timer reloads and counts down as soon as the 4 devices enter the powerdown mode and W83877ATF enters the powerdown mode as soon as it expires. Once any device is awakened, the global stand-by is also awakened. The initial count values of the devices are held in the configuration registers CR35 to CR39.

## 7.0 SERIAL IRQ

W83877ATF supports a serial IRQ scheme. This allows a signal line to be used to report the legacy ISA interrupt requests. Because more than one device may need to share the signal serial IRQ signal line, an open drain signal scheme is used. The clock source is the PCI clock. The serial interrupt is transferred on the IRQSER signal, one cycle consisting of three frames types: a start frame, several IRQ/Data frame, and one Stop frame. The serial interrupt scheme adheres to the *Serial IRQ Specification for PCI System, Version 6.0*.

### Timing Diagrams For IRQSER Cycle

#### Start Frame timing with source sampled a low pulse on IRQ1

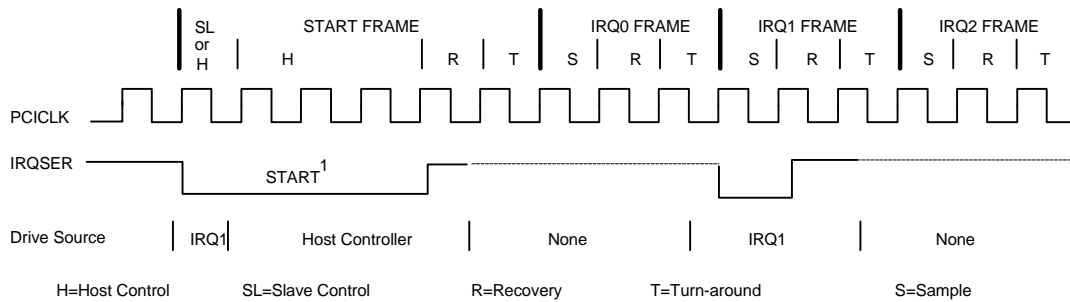

1. Start Frame pulse can be 4-8 clocks wide.

#### Stop Frame Timing with Host using 17 IRQSER sampling period

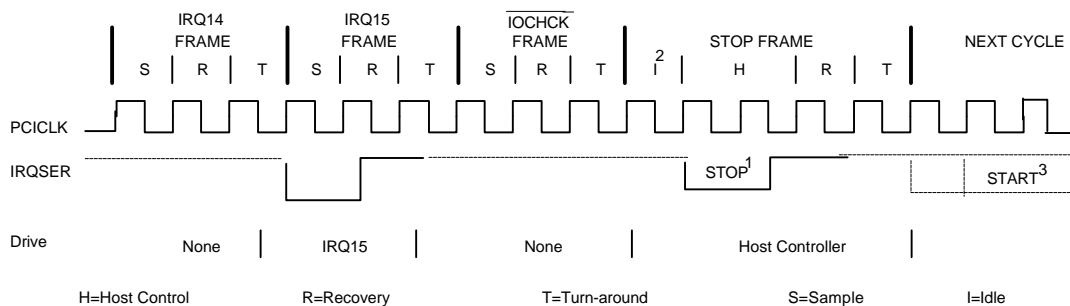

1. Stop pulse is 2 clocks wide for Quiet mode, 3 clocks wide for Continuous mode.
2. There may be none, one or more Idle states during the Stop Frame.
3. The next IRQSER cycle's Start Frame pulse may or may not start immediately after the turn-around clock of the Stop Frame.

## 7.1 Start Frame

There are two modes of operation for the IRQSER Start frame: Quiet mode and Continuous mode.

In the Quiet mode, the peripheral drives the SERIRQ signal active low for one clock, and then tri-states it. This brings all the states machines of the peripherals from idle to active states. The host controller will then take over driving IRQSER signal low in the next clock and will continue driving the IRQSER low for programmable 3 to 7 clock periods. This makes the total number of clocks low for 4 to 8 clock periods. After these clocks, the host controller will drive the IRQSER high for one clock and then tri-stated.

In the Continuous mode, only the host controller initiates the START frame to update IRQ/Data line information. The host controller drives the IRQSER signal low for 4 to 8 period clocks. Upon reset, the IRQSER signal is defaulted to the Continuous mode for the host controller to initiate the first Start frame.

## 7.2 IRQ/Data Frame

Once the start frame has been initiated, all the peripherals must start counting frames based on the rising edge of the start pulse. Each IRQ/Data Frame is three clocks: Sample phase, Recovery phase, and Turn-around phase.

During the Sample phase, the peripheral drives SERIRQ low if the corresponding IRQ should be active. If the corresponding IRQ is inactive, then IRQSER must be left tri-stated. During the Recovery phase, the peripheral device drives the IRQSER high. During the Turn-around phase, the peripheral device left the IRQSER tri-stated.

The IRQ/Data Frame has a number of specific order, as shown in Table 7-1.

Table 7-1 IRQSER Sampling periods

IRQ/Data Frame	Signal Sampled	# of clocks past Start
1	IRQ0	2
2	IRQ1	5
3	$\overline{\text{SMI}}$	8
4	IRQ3	11
5	IRQ4	14
6	IRQ5	17
7	IRQ6	20
8	IRQ7	23
9	IRQ8	26
10	IRQ9	29
11	IRQ10	32
12	IRQ11	35
13	IRQ12	38
14	IRQ13	41
15	IRQ14	44
16	IRQ15	47
17	$\overline{\text{IOCHCK}}$	50
18	$\overline{\text{INTA}}$	53
19	$\overline{\text{INTB}}$	56
20	$\overline{\text{INTC}}$	59
21	$\overline{\text{INTD}}$	62
32:22	Unassigned	95

### 7.3 Stop Frame

After all IRQ/Data Frames have been completed, the host controller will terminate IRQSER by a Stop frame. Only the host controller can initiate the Stop frame by driving IRQSER low for 2 or 3 clocks. If the Stop Frame is low for 2 clocks, the next IRQSER cycle's Sample mode is the Quiet mode. If the Stop Frame is low for 3 clocks, the next IRQSER cycle's Sample mode is the Continuous mode.

### 7.4 Reset and Initialization

After MR reset, IRQSER Slaves are put into the Continuous(Idle) mode. The Host Controller is responsible for starting the initial IRQSER Cycle to collect system's IRQ/Data default values. The system then follows with the Continuous/Quiet mode protocol (Stop Frame pulse width) for subsequent IRQSER cycles. It's the Host Controller's responsibility to provide the default values to 8259's and other system logic before the first IRQSER cycle is performed. For IRQSER system suspend, insertion, or removal application, the Host controller should be programmed into Continuous(Idle) mode first. This is to guarantee IRQSER bus in the Idle state before the system configuration changes.

## 8.0 EXTENDED FUNCTION REGISTERS

The W83877ATF provides many configuration registers for setting up different types of configurations. After power-on reset, the state of the hardware setting of each pin will be latched by the relevant configuration register to allow the W83877ATF to enter the proper operating configuration. To protect the chip from invalid reads or writes, the configuration registers cannot be accessed by the user.

There are four ways to enable the configuration registers to be read or written. HEFERE (CR0C bit 5) and HEFRAS (CR16 bit 0) can be used to select one out of these four methods of entering the Extended Function mode, as follows:

HEFRAS	HEFERE	address and value
0	0	write 88H to the location 250H
0	1	write 89H to the location 250H (power-on default)
1	0	write 86H to the location 3F0H twice
1	1	write 87H to the location 3F0H twice

First, a specific value must be written once (88H/89H) or twice (86H/87H) to the Extended Functions Enable Register (I/O port address 250H or 3F0H). Second, an index value (00H-19H, 20H-29H, 2CH-2DH, 31H-3AH, 40H-45H) must be written to the Extended Functions Index Register (I/O port address 251H or 3F0H) to identify which configuration register is to be accessed. The designer can then access the desired configuration register through the Extended Functions Data Register (I/O port address 252H or 3F1H).

After programming of the configuration register is finished, an additional value should be written to EFERs to exit the Extended Function mode, to prevent unintentional access to those configuration registers. In the case of EFER at 250H, this additional value can be any value other than 88H if HEFERE = 0 and 89H if HEFERE = 1. While EFER is at 3F0H, this additional value must be AAH. The designer can also set bit 6 of CR9 (LOCKREG) to high to protect the configuration registers against accidental accesses.

The configuration registers can be reset to their default or hardware settings only by a cold reset (pin MR = 1). A warm reset will not affect the configuration registers.

### 8.1 Extended Functions Enable Registers (EFERs)

After a power-on reset, the W83877ATF enters the default operating mode. Before the W83877ATF enters the extended function mode, a specific value must be programmed into the Extended Function Enable Register (EFER) so that the extended function register can be accessed. The Extended Function Enable Registers are write-only registers. On a PC/AT system, their port addresses are 250H or 3F0H (as described in the above section).

## 8.2 Extended Function Index Registers (EFIRs), Extended Function Data Registers (EFDRs)

After the extended function mode is entered, the Extended Function Index Register (EFIR) must be loaded with an index value (0H, 1H, 2H, ..., or 29H) to access Configuration Register 0 (CR0), Configuration Register 1 (CR1), Configuration Register 2 (CR2), and so forth through the Extended Function Data Register (EFDR). The EFIRs are write-only registers with port address 251H or 3F0H (as described in section 8.0) on PC/AT systems; the EFDRs are read/write registers with port address 252H or 3F1H (as described in section 8.0) on PC/AT systems. The function of each configuration register is described below.

### 8.2.1 Configuration Register 0 (CR0), default = 00H

When the device is in Extended Function mode and EFIR is 0H, the CR0 register can be accessed through EFDR. The bit definitions for CR0 are as follows:

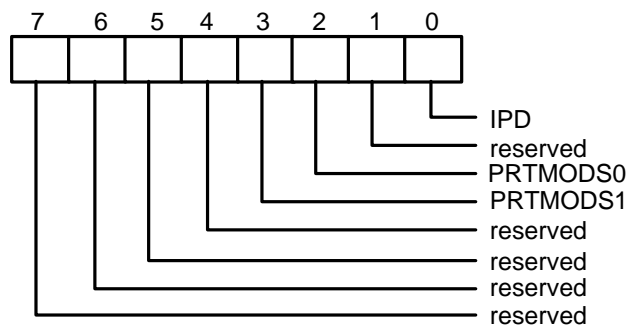

Bit 7-bit 4: Reserved.

PRTMOD1 PRTMOD0 (Bit 3, 2):

These two bits and PRTMOD2 (CR9 bit 7) determine the parallel port mode of the W83877ATF (as shown in the following Table 8-1).

Table 8-1

PRTMODS2 (BIT 7 OF CR9)	PRTMODS1 (BIT 3 OF CR0)	PRTMODS0 (BIT 2 OF CR0)	
0	0	0	Normal
0	0	1	EXTFDC
0	1	0	Reserved
0	1	1	EXT2FDD
1	0	0	Reserved
1	0	1	EPP/SPP
1	1	0	ECP
1	1	1	ECP/EPP

00	Normal Mode (Default), PRTMOD2 = 0 Default state after power-on reset. In this mode, the W83877ATF is fully compatible with the SPP and BPP mode.
01	Extension FDD Mode (EXTFDD), PRTMOD2 = 0
10	Reserved, PRTMOD2 = 0
11	Extension 2FDD Mode (EXT2FDD), PRTMOD2 = 0
00	Reserved, PRTMOD2 = 1
01	EPP Mode and SPP Mode, PRTMOD2 = 1
10	ECP Mode, PRTMOD2 = 1
11	ECP Mode and EPP Mode, PRTMOD2 = 1

Bit 1: Reserved.

IPD (Bit 0):

This bit is used to select the W83877ATF's legacy power-down functions. When the bit 0 is set to 1, the W83877ATF will stop its clock internally and enter power-down (IPD) mode immediately. The W83877ATF will not leave the power-down mode until either a system power-on reset from the MR pin occurs, or until this bit is reset to 0 to program the chip back to power-on state.

**8.2.2 Configuration Register 1 (CR1), default = 00H**

When the device is in Extended Function mode and EFIR is 01H, the CR1 register can be accessed through EFDR. The bit definitions are as follows:

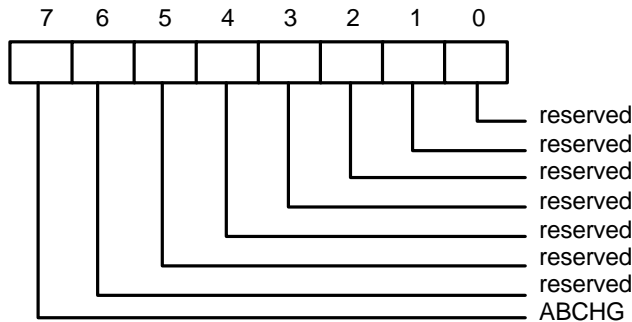

ABCHG (Bit 7):

This bit enables the FDC AB Change Mode. Default to be enabled at power-on reset.

0	Drives A and B assigned as usual
1	Drive A and drive B assignments exchanged

Bit 6-bit 0: Reserved.

**8.2.3 Configuration Register 2 (CR2), default = 00H**

When the device is in Extended Function mode and EFIR is 02H, the CR2 register can be accessed through EFDR. This register is reserved.

**8.2.4 Configuration Register 3 (CR3), default = 30H**

When the device is in Extended Function mode and EFIR is 03H, the CR3 register can be accessed through EFDR. The bit definitions are as follows:

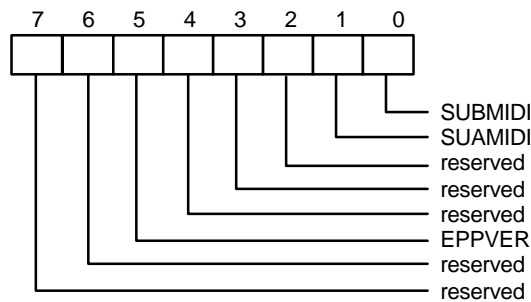

Bit 7-bit 6: Reserved.

EPPVER (Bit 5):

This bit selects the EPP version of parallel port:

- 0 Selects the EPP 1.9 version
- 1 Selects the EPP 1.7 version (default)

**Bit 4: Reserved.**

Bit 3-bit 2: Reserved.

SUAMIDI (Bit 1):

This bit selects the clock divide rate of UARTA.

- 0 Disables MIDI support, UARTA clock = 24 MHz divided by 13 (default)
- 1 Enables MIDI support, UARTA clock = 24 MHz divided by 12

SUBMIDI (Bit 0):

This bit selects the clock divide rate of UARTB.

- 0 Disables MIDI support, UARTB clock = 24 MHz divided by 13 (default)
- 1 Dnables MIDI support, UARTB clock = 24 MHz divided by 12

### 8.2.5 Configuration Register 4 (CR4), default = 00H

When the device is in Extended Function mode and EFIR is 04H, the CR4 register can be accessed through EFDR. The bit definitions are as follows:

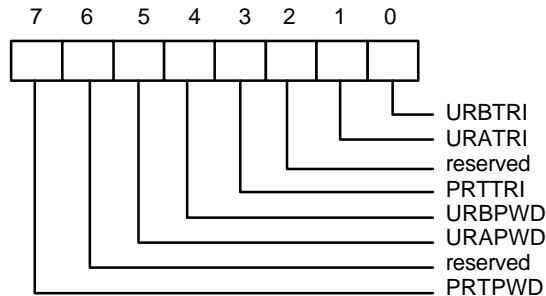

P RTPWD (Bit 7):

- 0 Supplies power to the parallel port (default)
- 1 Puts the parallel port in power-down mode

**Bit 6: Reserved.**

URAPWD (Bit 5):

- 0 Supplies power to COMA (default)
- 1 Puts COMA in power-down mode

URBPWD (Bit 4):

- 0 Supplies power to COMB (default)
- 1 Puts COMB in power-down mode

PRTTRI (Bit 3):

This bit enables or disables the tri-state outputs of parallel port in power-down mode.

- 0 The output pins of the parallel port will not be tri-stated when parallel port is in power-down mode. (default)
- 1 The output pins of the parallel port will be tri-stated when parallel port is in power-down mode.

**Bit 2: Reserved.**

URATRI (Bit 1):

This bit enables or disables the tri-state outputs of UARTA in power-down mode.

- 0 The output pins of UARTA will not be tri-stated when UARTA is in power-down mode.
- 1 The output pins of UARTA will be tri-stated when UARTA is in power-down mode.

URBTRI (Bit 0):

This bit enables or disables the tri-state outputs of UARB in power-down mode.

- 0 The output pins of UARB will not be tri-stated when UARB is in power-down mode.
- 1 The output pins of UARB will be tri-stated when UARB is in power-down mode.

**8.2.6 Configuration Register 5 (CR5), default = 00H**

When the device is in Extended Function mode and EFIR is 05H, the CR5 register can be accessed through EFDR. The bit definitions are as follows:

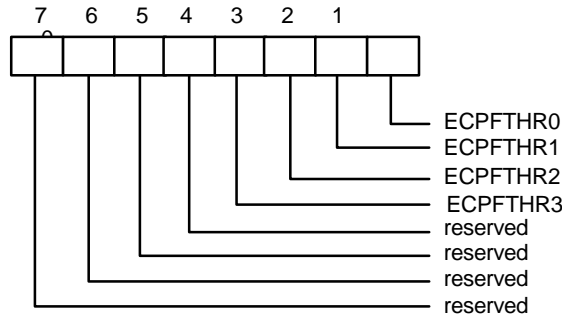

Bit 7- bit 4: Reserved

ECPFTHR3-0 (bit 3-0): These four bits define the FIFO threshold for the ECP mode parallel port. The default value is 0000 after power-up.

**8.2.7 Configuration Register 6 (CR6), default = 00H**

When the device is in Extended Function mode and EFIR is 06H, the CR6 register can be accessed through EFDR. The bit definitions are as follows:

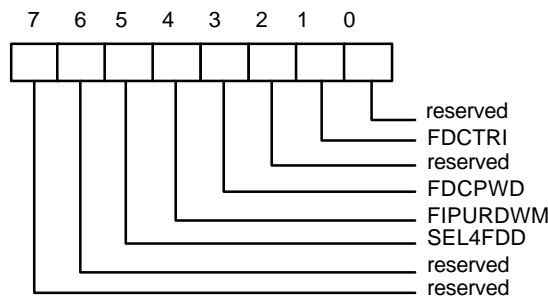

Bit 7- bit 6: Reserved

SEL4FDD (Bit 5): Selects four FDD mode

- 0 Selects two FDD mode (default, see Table 8-2)
- 1 Selects four FDD mode

$\overline{DSA}$ ,  $\overline{DSB}$ ,  $\overline{MOA}$  and  $\overline{MOB}$  output pins are encoded as show in Table 8-3 to select four drives.

Table 8-2

DO REGISTER ( 3F2H )						MOB	MOA	DSB	DSA	DRIVE SELECTED
Bit 7	Bit 6	Bit 5	Bit 4	Bit 1	Bit 0					
0	0	0	0	0	0	1	1	1	1	--
0	0	0	1	0	0	1	0	1	0	FDD A
0	0	1	0	0	1	0	1	0	1	FDD B
0	1	0	0	0	1	1	1	1	1	--
1	0	0	0	1	1	1	1	1	1	--

Table 8-3

DO REGISTER ( 3F2H )						MOB	MOA	DSB	DSA	DRIVE SELECTED
Bit 7	Bit 6	Bit 5	Bit 4	Bit 1	Bit 0					
0	0	0	0	X	X	1	1	x	x	--
0	0	0	1	0	0	0	0	0	0	FDD A
0	0	1	0	0	1	0	0	0	1	FDD B
0	1	0	0	1	0	0	0	1	0	FDD C
1	0	0	0	1	1	0	0	1	1	FDD D

**FIPURDWN (Bit 4):**

This bit controls the internal pull-up resistors of the FDC input pins  $\overline{RDATA}$ ,  $\overline{INDEX}$ ,  $\overline{TRAK0}$ ,  $\overline{DSKCHG}$ , and  $\overline{WP}$ .

- 0 The internal pull-up resistors of FDC are turned on. (default)
- 1 The internal pull-up resistors of FDC are turned off.

**FDCPWD (Bit 3):**

This bit controls the power to the FDC.

- 0 Power is supplied to the FDC. (default)
- 1 Puts the FDC in power-down mode.

**Bit 2: Reserved.**
**FDCTRI (Bit 1):**

This bit enables or disables the tri-state outputs of the FDC in power-down mode.

- 0 The output pins of the FDC will not be tri-stated when FDC is in power-down mode.
- 1 The output pins of the FDC will be tri-stated when FDC is in power-down mode.

**Bit 0: Reserved.**

### 8.2.8 Configuration Register 7 (CR7), default = 00H

When the device is in Extended Function mode and EFIR is 07H, the CR7 register can be accessed through EFDR. The bit definitions are as follows:

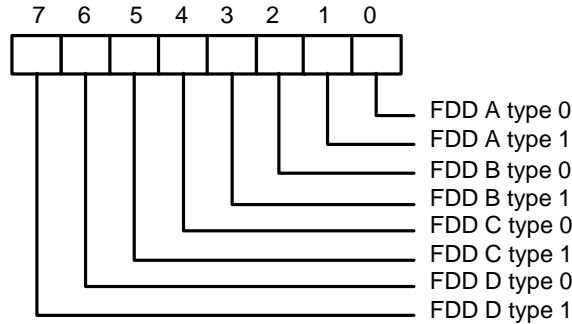

FDD D type 1, 0 (Bit 7, 6):

These two bits select the type of FDD D.

- 00 Selects normal mode. When  $\overline{RWC} = 0$ , the data transfer rate is 250 Kb/s. When  $\overline{RWC} = 1$ , the data transfer rate is 500 Kb/s.

Three mode FDD select (EN3MODE = 1):

- 01  $\overline{RWC} = 0$ , selects 1.2 MB high-density FDD.
- 10  $\overline{RWC} = 1$ , selects 1.44 MB high-density FDD.
- 11 Don't care  $\overline{RWC}$ , selects 720 KB double-density FDD.

FDD C type 1, 0 (Bit 5, 4):

These two bits select the type of FDD C.

- 00 Selects normal mode. When  $\overline{RWC} = 0$ , the data transfer rate is 250 kb/s. When  $\overline{RWC} = 1$ , the data transfer rate is 500 kb/s.

Three mode FDD select (EN3MODE = 1):

- 01  $\overline{RWC} = 0$ , selects 1.2 MB high-density FDD.
- 10  $\overline{RWC} = 1$ , selects 1.44 MB high-density FDD.
- 11 Don't care  $\overline{RWC}$ , selects 720 KB double-density FDD.

FDD B type 1, 0 (Bit 3, 2):

These two bits select the type of FDD B.

- 00 Selects normal mode. When  $\overline{RWC} = 0$ , the data transfer rate is 250 Kb/s. When  $\overline{RWC} = 1$ , the data transfer rate is 500 Kb/s.

Three mode FDD select (EN3MODE = 1):

- 01  $\overline{RWC} = 0$ , selects 1.2 MB high-density FDD.
- 10  $\overline{RWC} = 1$ , selects 1.44 MB high-density FDD.
- 11 Don't care  $\overline{RWC}$ , selects 720 KB double-density FDD.

FDD A type 1, 0 (Bit 1, 0):

These two bits select the type of FDD A.

- 00 Selects normal mode. When  $\overline{RWC} = 0$ , the data transfer rate is 250 Kb/s. When  $\overline{RWC} = 1$ , the data transfer rate is 500 Kb/s.

Three mode FDD select (EN3MODE = 1):

- 01  $\overline{RWC} = 0$ , selects 1.2 MB high-density FDD.
- 10  $\overline{RWC} = 1$ , selects 1.44 MB high-density FDD.
- 11 Don't care  $\overline{RWC}$ , selects 720 KB double-density FDD.

### 8.2.9 Configuration Register 8 (CR8), default = 00H

When the device is in Extended Function mode and EFIR is 08H, the CR8 register can be accessed through EFDR. The bit definitions are as follows:

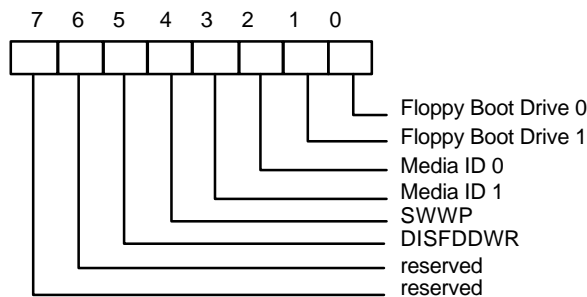

Bit 7 - bit 6: Reserved.

DISFDDWR (Bit 5):

This bit enables or disables FDD write data.

- 0 Enables FDD write
- 1 Disables FDD write (forces pins  $\overline{WE}$ ,  $\overline{WD}$  to stay high)

Once this bit is set high, the FDC operates normally, but because pin  $\overline{WE}$  is inactive, the FDD will not write data to diskettes. For example, if a diskette is formatted with DISFDDWR = 1, after the format command has been executed, messages will be displayed that appear to indicate that the format is complete. If the diskette is removed from the disk drive and inserted again, however, typing the DIR command will reveal that the contents of the diskette have not been modified and the diskette was not actually reformatted.

Because as the operating system (e.g., DOS) reads the diskette files, it keeps the files in memory. If there is a write operation, DOS will write data to the diskette and memory simultaneously. When DOS wants to read the diskette, it will first search the files in memory. If DOS finds the file in memory, it will not issue a read command to read the diskette. When DISFDDWR = 1, DOS still writes data to the diskette and memory, but only the data in memory are updated. If a read operation is performed, data are read from memory first, and not from the diskette. The action of removing the diskette from the drive and inserting it again forces the DSKCHG pin active. DOS will then read the contents of the diskette and will show that the contents have not been modified. The same holds true with write commands.

This disable FDD write function allows users to protect diskettes against computer viruses by ensuring that no data are written to the diskette.

SWWP (Bit 4):

- 0 Normal, use  $\overline{WP}$  to determine whether the FDD is write-protected or not
- 1 FDD is always write-protected

Media ID 1 Media ID 0 (Bit 3, 2):

These two bits hold the media ID bit 1, 0 for three mode

Floppy Boot Drive 1 Floppy Boot Drive 0 (Bit 1, 0)

These two bits hold the value of floppy boot drive 1 and drive 0 for three mode

**8.2.10 Configuration Register 9 (CR9), default = 0DH**

When the device is in Extended Function mode and EFIR is 09H, the CR9 register can be accessed through EFDR. The bit definitions are as follows:

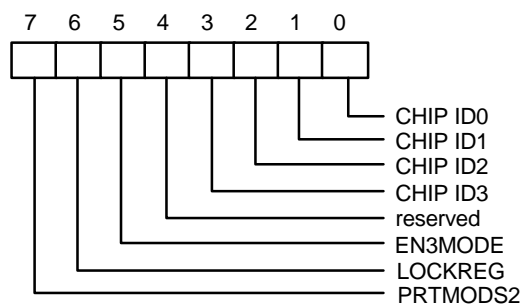

PRTMODS2 (Bit 7):

This bit and PRTMODS1, PRTMODS0 (bits 3, 2 of CR0) select the operating mode of the W83877ATF. Refer to the descriptions of CR0.

LOCKREG (Bit 6):

This bit enables or disables the reading and writing of all configuration registers.

- 0 Enables the reading and writing of CR0-CR45
- 1 Disables the reading and writing of CR0-CR45 (locks W83877ATF extension functions)

EN3MODE (Bit 5):

This bit enables or disables three mode FDD selection. When this bit is high, it enables the read/write 3F3H register.

- 0 Disables 3 mode FDD selection
- 1 Enables 3 mode FDD selection

When three mode FDD function is enabled, the value of  $\overline{RWC}$  depends on bit 5 and bit 4 of TDR(3F3H). The values of  $\overline{RWC}$  and their meaning are shown in Table 8-4.

Table 8-4

BIT 5 OF TDR	BIT 4 OF TDR	RWC	$\overline{RWC} = 0$	$\overline{RWC} = 1$
0	0	Normal	250K bps	500K bps
0	1	0	1.2 M FDD	X
1	0	1	X	1.4M FDD
1	1	X	X	X

Bit 4: Reserved.

CHIP ID 3, CHIP ID 2, CHIP ID 1, CHIP ID 0 (Bit 3-bit 0):

These four bits are read-only bits that contain chip identification information. The value is 0DH for W83877ATF during a read.

### 8.2.11 Configuration Register A (CR0A), default = 00H

When the device is in Extended Function mode and EFIR is 0AH, the CRA register can be accessed through EFDR. This register is reserved.

### 8.2.12 Configuration Register B (CR0B), default = 0CH

When the device is in Extended Function mode and EFIR is 0BH, the CRB register can be accessed through EFDR. The bit definitions are as follows:

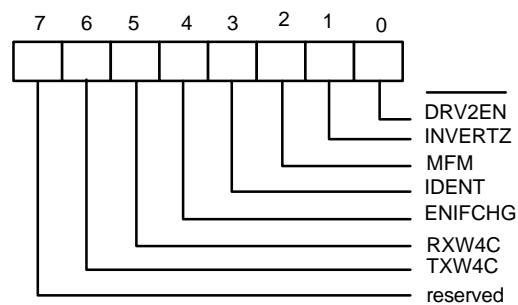

Bit 7: Reserved.

**TXW4C (Bit 6):**

This bit is active high. When active, the IR controller will wait for a 4-character period of time from the end of last receiving before it can start transmitting data.

**RXW4C (Bit 5):**

This bit is active high. When active, the IR controller will wait for a 4-character period of time from the end of last transmitting before it can start receiving data.

**ENIFCHG (Bit 4):**

This bit is active high. When active, it enables host interface mode change, which is determined by IDENT (Bit 3) and MFM (Bit 2).

**IDENT (Bit 3):**

This bit indicates the type of drive being accessed and changes the level on  $\overline{RWC}$  (pin 87).

- 0  $\overline{RWC}$  will be active low for high data rates (typically used for 3.5" drives)
- 1  $\overline{RWC}$  will be active high for high data rates (typically used for 5.25" drives)

When hardware reset or ENIFCHG is a logic 1, IDENT and MFM select one of three interface modes, as shown in Table 8-5.

Table 8-5

IDENT	MFM	INTERFACE
0	0	Model 30 mode
0	1	PS/2 mode
1	0	AT mode
1	1	AT mode

**MFM (Bit 2):**

This bit and IDENT select one of the three interface modes (PS/2 mode, Model 30, or PC/AT mode).

**INTVERTZ (Bit 1):**

This bit determines the polarity of all FDD interface signals.

- 0 FDD interface signals are active low
- 1 FDD interface signals are active high

**$\overline{DRV2EN}$  (Bit 0): PS/2 mode only**

When this bit is a logic 0, indicates a second drive is installed and is reflected in status register A.

**8.2.13 Configuration Register C (CR0C), default = 28H**

When the device is in Extended Function mode and EFIR is 0CH, the CR0C register can be accessed through EFDR. The bit definitions are as follows:

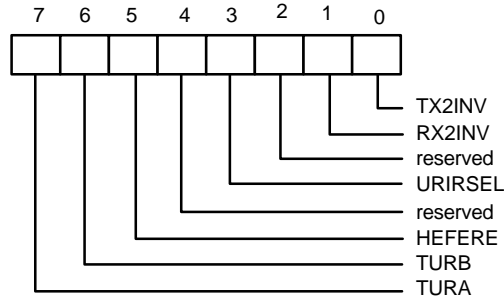

TURA (Bit 7):

- 0 the clock source of UART A is 1.8462 MHz (24 MHz divide 13) (default)
- 1 the clock source of UART A is 24 MHz, it can make the baudrate of UART A up to 1.5 MHz

TURB (Bit 6):

- 0 the clock source of UART B is 1.8462 MHz (24 MHz divide 13) (default)
- 1 the clock source of UART B is 24 MHz, it can make the baudrate of UART A up to 1.5 MHz

HEFERE (Bit 5): this bit combines with HEFRAS (CR16 bit 0) to define how to enable Extended Function Registers.

HEFRAS	HEFERE	address and value
0	0	write 88H to the location 250H
0	1	write 89H to the location 250H (default)
1	0	write 86H to the location 3F0H twice
1	1	write 87H to the location 3F0H twice

The default value of HEFERE is 1.

Bit 4: Reserved.

URIRSEL (Bit 3):

- 0 select UART B as IR function.
- 1 select UART B as normal function.

The default value of URIRSEL is 1.

Bit 2: Reserved.

RX2INV (Bit 1):

- 0 the SINB pin of UART B function or IRRX pin of IR function in normal condition.
- 1 inverse the SINB pin of UART B function or IRRX pin of IR function

TX2INV (Bit 0):

- 0 the SOUTB pin of UART B function or IRTX pin of IR function in normal condition.
- 1 inverse the SOUTB pin of UART B function or IRTX pin of IR function.

**8.2.14 Configuration Register D (CR0D), default = A3H**

When the device is in Extended Function mode and EFIR is 0DH, the CR0D register can be accessed through EFDR. The bit definitions are as follows:

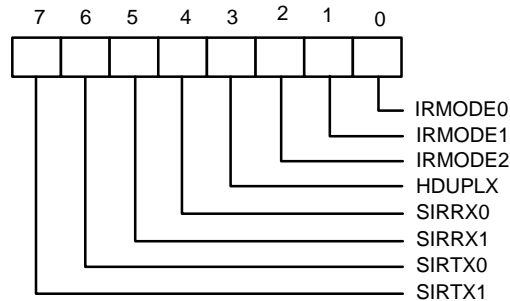

SIRTX1 (Bit 7): IRTX pin selection bit 1

SIRTX0 (Bit 6): IRTX pin selection bit 0

SIRTX1	SIRTX0	IRTX output on pin
0	0	disabled
0	1	IRTX1 (pin 43)
1	0	IRTX2 (pin 95)
1	1	disabled

SIRRX1 (Bit 5): IRRX pin selection bit 1

SIRRX0 (Bit 4): IRRX pin selection bit 0

SIRRX1	SIRRX0	IRRX input on pin
0	0	disabled
0	1	IRRX1 (pin 42)
1	0	IRRX2 (pin 94)
1	1	disabled

HDUPLX (Bit 3):

0 The IR function is Full Duplex.

1 The IR function is Half Duplex.

IRMODE2 (Bit 2): IR function mode selection bit 2

IRMODE1 (Bit 1): IR function mode selection bit 1

IRMODE0 (Bit 0): IR function mode selection bit 0

IR MODE	IR FUNCTION	IRTX	IRRX
00X	Disable	tri-state	high
010*	IrDA	Active pulse 1.6 $\mu$ S	Demodulation into SINB
011*	IrDA	Active pulse 3/16 bit time	Demodulation into SINB
100	ASK-IR	Inverting IRTX pin	routed to SINB
101	ASK-IR	Inverting IRTX & 500 KHZ clock	routed to SINB
110	ASK-IR	Inverting IRTX	Demodulation into SINB
111*	ASK-IR	Inverting IRTX & 500 KHZ clock	Demodulation into SINB

Note: The notation is normal mode in the IR function.

The SIR schematic diagram for registers CRC and CRD is shown below.

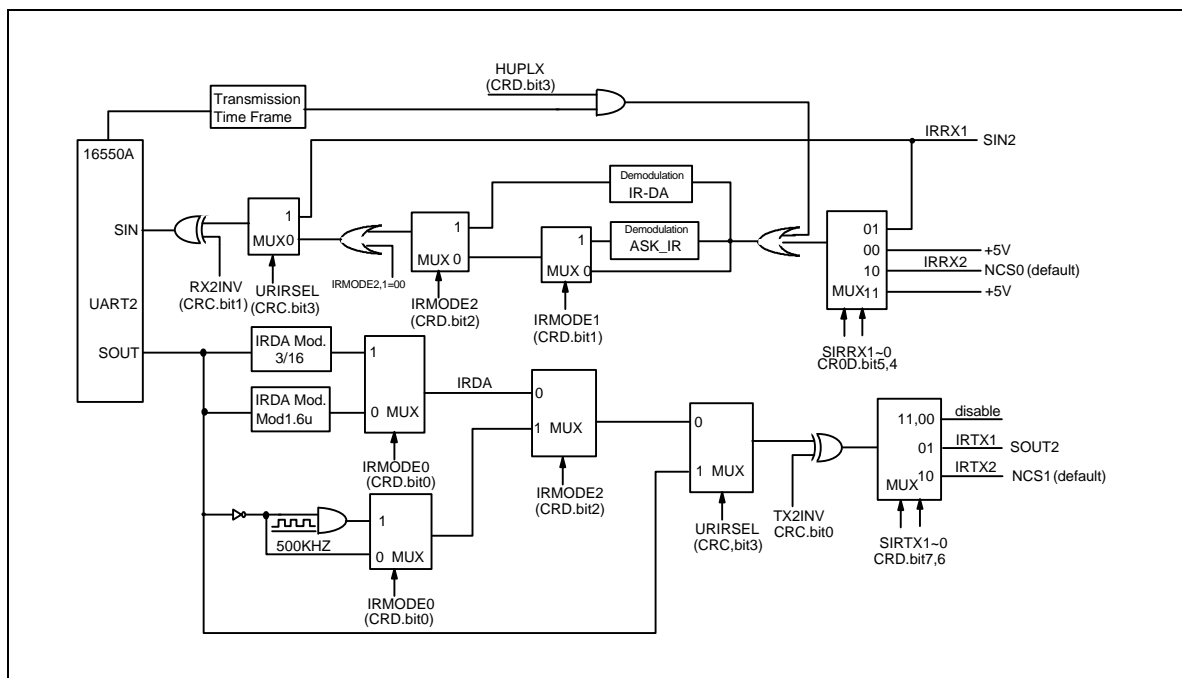

### 8.2.15 Configuration Register E (CR0E), Configuration Register F (CR0F)

Reserved for testing. Should be kept all 0's.

**8.2.16 Configuration Register 10 (CR10), default = 00H**

When the device is in Extended Function mode and EFIR is 10H, the CR10 register can be accessed through EFDR. The bit definitions are as follows:

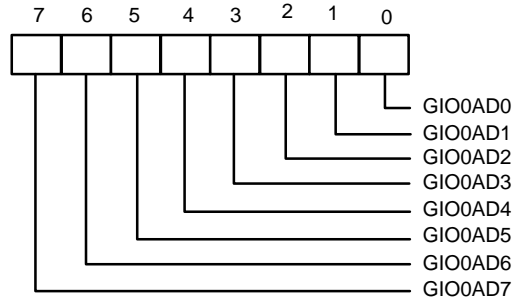

GIO0AD7-GIO0AD0 (Bit 7-bit 0): GIOP0 (pin 92) address bit 7 - bit 0.

**8.2.17 Configuration Register 11 (CR11), default = 00H**

When the device is in Extended Function mode and EFIR is 11H, the CR11 register can be accessed through EFDR. The bit definitions are as follows:

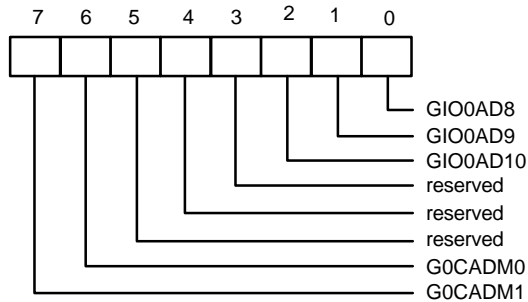

G0CADM1-G0CADM0 (Bit 7, 6): GIOP0 address bit compare mode selection

G0CADM1	G0CADM0	GIOP0 pin
0	0	compare GIO0AD10-GIO0AD0 with SA10-SA0
0	1	compare GIO0AD10-GIO0AD1 with SA10-SA1
1	0	compare GIO0AD10-GIO0AD2 with SA10-SA2
1	1	compare GIO0AD10-GIO0AD3 with SA10-SA3

Bit 5-bit 3: Reserved

GIO0AD10-GIO0AD8 (Bit 2-bit 0): GIOP0 (pin 92) address bit 10-bit 8.

**8.2.18 Configuration Register 12 (CR12), default = 00H**

When the device is in Extended Function mode and EFIR is 12H, the CR12 register can be accessed through EFDR. The bit definitions are as follows:

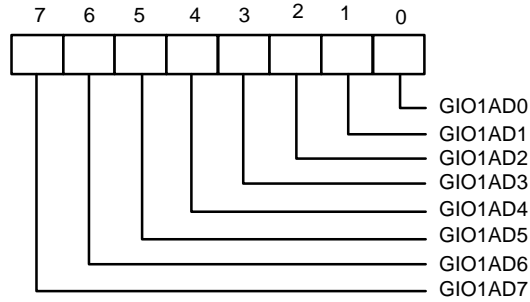

GIO1AD7-GIO1AD0 (Bit 7-bit 0): GIOP1 (pin 96) address bit 7-bit 0.

**8.2.19 Configuration Register 13 (CR13), default = 00H**

When the device is in Extended Function mode and EFIR is 13H, the CR13 register can be accessed through EFDR. The bit definitions are as follows:

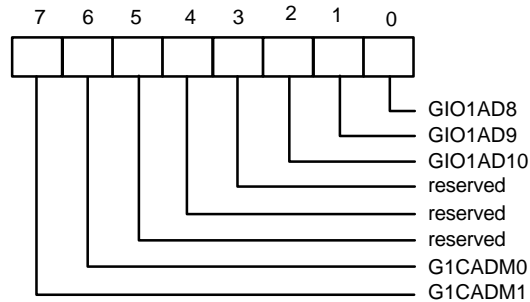

G1CADM1-G1CADM0 (bit 7, 6): GIOP1 address bit compare mode selection

G1CADM1	G1CADM0	GIOP1 pin
0	0	compare GIO1AD10-GIO1AD0 with SA10-SA0
0	1	compare GIO1AD10-GIO1AD1 with SA10-SA1
1	0	compare GIO1AD10-GIO1AD2 with SA10-SA2
1	1	compare GIO1AD10-GIO1AD3 with SA10-SA3

Bit 5- bit 3: Reserved

GIO1AD10-GIO1AD8 (Bit 2-bit 0): GIOP1 (pin 96) address bit 10-bit 8.

**8.2.20 Configuration Register 14 (CR14), default = 00H**

When the device is in Extended Function mode and EFIR is 14H, the CR14 register can be accessed through EFDR. The bit definitions are as follows:

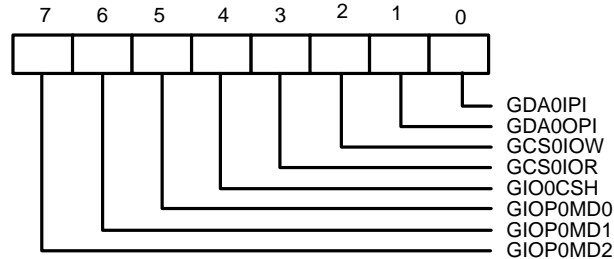

GIOP0MD2-GIOP0MD0 (Bit 7-bit 5): GIOP0 pin mode selection

GIOP0MD2	GIOP0MD1	GIOP0MD0	GIOP0 pin
0	0	0	inactive (tri-state)
0	0	1	as a data output pin (SD0→GIOP0), when (AEN = L) AND (NIOW = L) AND (SA10-0 = GIO0AD10-0), the value of SD0 will be present on GIOP0
0	1	0	as a data input pin (GIOP0→SD0), when (AEN = L) AND (NIOR = L) AND (SA10-0 = GIO0AD10-0), the value of GIOP0 will be present on SD0
0	1	1	as a data input/output pin (GIOP0↔SD0). When (AEN = L) AND (NIOW = L) AND (SA10-0 = GIO0AD10-0), the value of SD0 will be present on GIOP0 When (AEN = L) AND (NIOR = L) AND (SA10-0 = GIO0AD10-0), the value of GIOP0 will be present on SD0
1	X	X	as a Chip Select pin, the pin will be active at (AEN = L) AND (SA10-0 = GIO0AD10-0) OR (NIOR = L) OR (NIOW = L)

GIO0CSH(Bit 4):

0	the Chip Select pin will be active LOW when (AEN = L) AND (SA10-0 = GIO0AD10-0) OR (NIOR = L) OR (NIOW = L)
1	the Chip Select pin will be active HIGH when (AEN = L) AND (SA10-0 = GIO0AD10-0) OR (NIOR = L) OR (NIOW = L)

GCS0IOR (Bit 3): See below.

GCS0IOW (Bit 2): See below.

GCS0IOR	GCS0IOW	
0	0	GIOP0 functions as a Chip Select pin, and will be active when (AEN = L) AND (SA10-0 = GIO0AD10-0)
0	1	GIOP0 functions as a Chip Select pin, and will be active when (AEN = L) AND (SA10-0 = GIO0AD10-0) AND (NIOW = L)
1	0	GIOP0 functions as a Chip Select pin, and will be active when (AEN = L) AND (SA10-0 = GIO0AD10-0) AND (NIOR = L)
1	1	GIOP0 functions as a Chip Select pin, and will be active when (AEN = L) AND (SA10-0 = GIO0AD10-0) AND (NIOW = L OR NIOR = L)

GDA0OPI (Bit 1): See below.

GDA0IPI (Bit 0): See below.

GDA0OPI	GDA0IPI	
0	0	GIOP0 functions as a data pin, and GIOP0→SD0, SD0→GIOP0
0	1	GIOP0 functions as a data pin, and inverse GIOP0→SD0, SD0→GIOP0
1	0	GIOP0 functions as a data pin, and GIOP0→SD0, inverse SD0→GIOP0
1	1	GIOP0 functions as a data pin, and inverse GIOP0→SD0, inverse SD0→GIOP0

**8.2.21 Configuration Register 15 (CR15), default = 00H**

When the device is in Extended Function mode and EFIR is 15H, the CR15 register can be accessed through EFDR. The bit definitions are as follows:

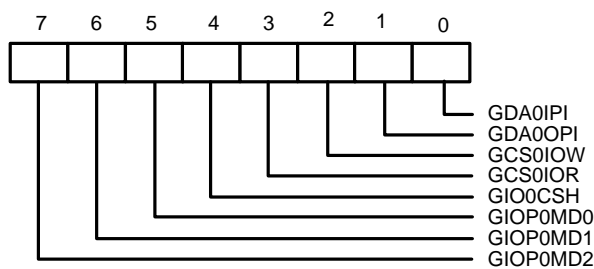

GIOP1MD2-GIOP1MD0 (Bit 7-bit 5): GIOP1 pin mode selection

GIOP1MD2	GIOP1MD1	GIOP1MD0	GIOP1 pin
0	0	0	inactive (tri-state)
0	0	1	as a data output pin (SD1→GIOP1), when (AEN = L) AND (NIOW = L) AND (SA10-0 = GIO1AD10-0), the value of SD1 will be present on GIOP1
0	1	0	as a data input pin (GIOP1→SD1), when (AEN = L) AND (NIOR = L) AND (SA10-0 = GIO1AD10-0), the value of GIOP1 will be present on SD1
0	1	1	as a data input/output pin (GIOP1↔SD1). When (AEN = L) AND (NIOW = L) AND (SA10-0 = GIO1AD10-0), the value of SD1 will be present on GIOP1 When (AEN = L) AND (NIOR = L) AND (SA10-0 = GIO1AD10-0), the value of GIOP1 will be present on SD1
1	X	X	as a Chip Select pin, the pin will be active at (AEN = L) AND (SA10-0 = GIO1AD10-0) OR (NIOR = L) OR (NIOW = L)

GIO1CSH (Bit 4):

0	the Chip Select pin will active LOW when (AEN = L) AND (SA10-0 = GIOAD10-0) OR (NIOR = L) OR (NIOW = L)
1	the Chip Select pin will active HIGH when (AEN = L) AND (SA10-0 = GIOAD10-0) OR (NIOR = L) OR (NIOW = L)

GCS1IOR (Bit 3): See below.

GCS1IOW (Bit 2): See below.

GCS1IOR	GCS1IOW	
0	0	GIOP1 functions as a Chip Select pin, and will be active when (AEN = L) AND (SA10-0 = GIO1AD10-0)
0	1	GIOP1 functions as a Chip Select pin, and will be active when (AEN = L) AND (SA10-0 = GIO1AD10-0) AND (NIOW = L)
1	0	GIOP1 functions as a Chip Select pin, and will be active when (AEN = L) AND (SA10-0 = GIO1AD10-0) AND (NIOR = L)
1	1	GIOP1 functions as a Chip Select pin, and will be active when (AEN = L) AND (SA10-0 = GIO1AD10-0) AND (NIOW = L OR NIOR = L)

GDA0OPI (Bit 1): See below.

GDA1IPI (Bit 0): See below.

GDA1OPI	GDA1IPI	
0	0	GIOP1 functions as a data pin, and GIOP1→SD1, SD1→GIOP1
0	1	GIOP1 functions as a data pin, and inverse GIOP1→SD1, SD1→GIOP1
1	0	GIOP1 functions as a data pin, and GIOP1→SD1, inverse SD1→GIOP1
1	1	GIOP1 functions as a data pin, and inverse GIOP1→SD1, inverse SD1→GIOP1

### 8.2.22 Configuration Register 16 (CR16), default = 04H

When the device is in Extended Function mode and EFIR is 16H, the CR16 register can be accessed through EFDR. The bit definitions are as follows:

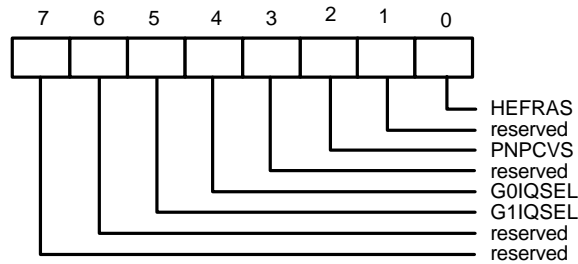

Bit 7-bit 6: Reserved.

#### G1IQSEL (Bit 5):

0	pin 96 function as IRQ_A.
1	pin 96 function as GIO1.

The corresponding power-on setting pin is NRTSB (pin 45).

#### G0IQSEL (Bit 4):

0	pins 92 function as IRQ_B.
1	pins 92 function as GIO0.

The corresponding power-on setting pin is NRTSB (pin 45).

#### Bit 3: Reserved.

#### PNP CVS (bit 2):

0	PnP-related registers (CR20, CR23-29) reset to be all 0s.
1	default settings for these registers.

The corresponding power-on setting pin is NRTSA (pin 36).

PnP register	PNPCVS = 1	PNPCVS = 0
CR20	FCH	00H
CR23	DEH	00H
CR24	FEH	00H
CR25	BEH	00H
CR26	23H	00H
CR27	05H	00H
CR28	43H	00H
CR29	60H	00H

Note: The new value of PNPCVS must be complementary to the old one to make an effective change. For example, the user must set PNPCVS to 1 first and then reset it to 0 to reset these PnP registers if the present value of PNPCVS is 0.

**Bit 1: Reserved.**

HEFRAS (Bit 0): combines with HEFERE (bit 5 of CR0C) to define how to access Extended Function Registers (refer to bit 5 of CR0C description). The corresponding power-on setting pin is NDTRA (pin 35).

**8.2.23 Configuration Register 17 (CR17), default = 00H**

When the device is in Extended Function mode and EFIR is 17H, the CR17 register can be accessed through EFDR. The bit definitions are as follows:

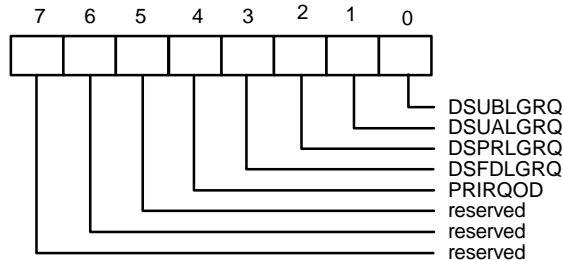

Bit 7-bit 5: Reserved.

PRIRQOD (Bit 4):

0	printer IRQ ports are totem-poles in SPP mode and open-drains in ECP/EPP mode.
1	printer IRQ ports are totem-poles in all modes.

DSFDLGRQ (Bit 3):

0	enable FDC legacy mode on IRQ and DRQ selections. DO register bit 3 has effect on selecting IRQ.
1	disable FDC legacy mode on IRQ and DRQ selections. DO register bit 3 has no effect on selecting IRQ.

DSPRLGRQ (Bit 2):

0	enable PRT legacy mode on IRQ and DRQ selections. DCR bit 4 has effect on selecting IRQ.
1	disable PRT legacy mode on IRQ and DRQ selections. DCR bit 4 has no effect on selecting IRQ.

DSUALGRQ (Bit 1):

0	enable UART A legacy mode on IRQ selection. MCR bit 3 has effect on selecting IRQ.
1	disable UART A legacy mode on IRQ selection. MCR bit 3 has no effect on selecting IRQ.

DSUBLGRQ (Bit 0):

0	enable UART B legacy mode on IRQ selection. MCR bit 3 has effect on selecting IRQ.
1	disable UART B legacy mode on IRQ selection. MCR bit 3 has no effect on selecting IRQ.

### 8.2.24 Configuration Register 18 (CR18), default=00H

When the device is in Extended Function mode and EFIR is 18H, the CR18 register can be accessed through EFDR. The bit definitions are as follows:

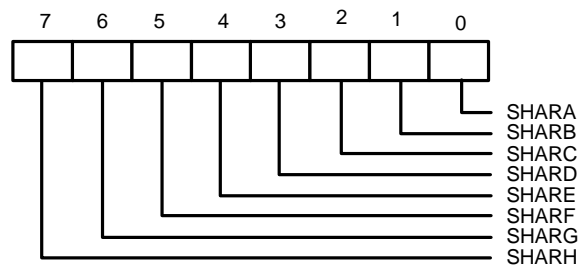

This register is used to select whether these interrupt request pins are in the IRQ sharing mode. While in the IRQ sharing mode, the corresponding pin is low active for 200ns for the interrupt request and keeps tri-stated otherwise.

SHARH (Bit 7):

0	pin IRQ_H in the legacy ISA IRQ mode.
1	pin IRQ_H in the IRQ sharing mode.

SHARG (Bit 6):

0	pin IRQ_G in the legacy ISA IRQ mode.
1	pin IRQ_G in the IRQ sharing mode.

SHARF (Bit 5):

0	pin IRQ_F in the legacy ISA IRQ mode.
1	pin IRQ_F in the IRQ sharing mode.

SHARE (Bit 4):

0	pin IRQ_E in the legacy ISA interrupt mode.
1	pin IRQ_E in the IRQ sharing mode.

SHARD (Bit 3):

0	pin IRQ_D in the legacy ISA IRQ mode.
1	pin IRQ_D in the IRQ sharing mode.

SHARC (Bit 2):

0	pin IRQ_C in the legacy ISA IRQ mode.
1	pin IRQ_C in the IRQ sharing mode.

SHARB(Bit 1):

0	pin IRQ_B in the legacy ISA IRQ mode.
1	pin IRQ_B in the IRQ sharing mode.

SHARA (Bit 0):

0	pin IRQ_A in the legacy ISA IRQ mode.
1	pin IRQ_A in the IRQ sharing mode.

**8.2.25 Configuration Register 19 (CR19), default=00H**

When the device is in Extended Function mode and EFIR is 19H, the CR19 register can be accessed through EFDR. The bit definitions are as follows:

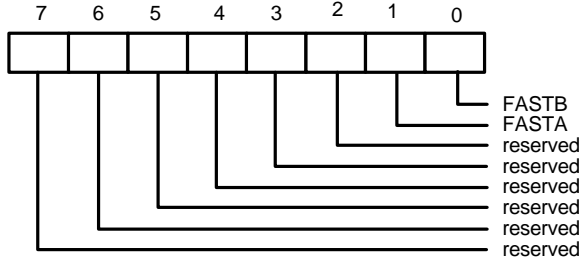

This register is used for the high speed modem application. While the bit is set to logic 1, it can increase the baudrate of UART to 921.2KBPS (the clock source of UART is 14.769MHz) for high speed transmit/receive.

Bit 7 - bit 2: Reserved.

FASTA (Bit 1):

0	the clock source of UART A is the same as the frequency of TURA (CR0C bit 7) and SUAMIDI (CR3 bit 1) selected.
1	the clock source of UART A is 14.769MHZ.

FASTB (Bit 0):

0	the clock source of UART B is the same as the frequency of TURB (CR0C bit 6) and SUBMIDI (CR3 bit 0) selected.
1	the clock source of UART B is 14.769MHZ.

**8.2.26 Configuration Register 20 (CR20)**

When the device is in Extended Function mode and EFIR is 20H, the CR20 register can be accessed through EFDR. Default = FCH if CR16 bit 2 = 1; default = 00H if CR16 bit 2 = 0. The bit definitions are as follows:

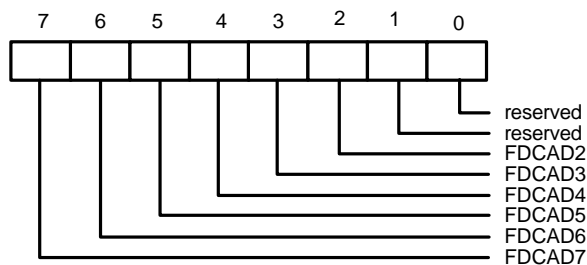

This register is used to select the base address of the Floppy Disk Controller (FDC) from 100H-3F0H on 16-byte boundaries. NCS = 0 and A10 = 0 are required to access the FDC registers. A[3:0] are always decoded as 0xxxb.

FDCAD7-FDCAD2 (Bit 7-bit 2): match A[9:4]. Bit 7 = 0 and bit 6 = 0 disable this decode.

Bit 1-bit 0: Reserved, fixed at zero.

**8.2.27 Configuration Register 23 (CR23)**

When the device is in Extended Function mode and EFIR is 23H, the CR23 register can be accessed through EFDR. Default = DEH if CR16 bit 2 = 1; default = 00H if CR16 bit 2 = 0. The bit definitions are as follows:

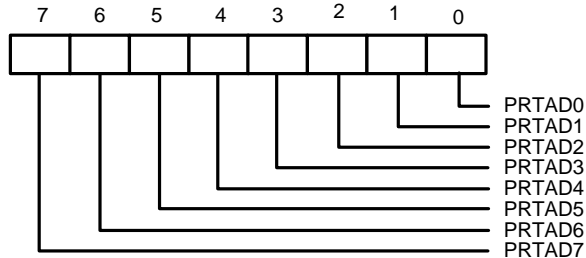

This register is used to select the base address of the parallel port. If EPP is disable, the parallel port can be set from 100H-3FCH on 4-byte boundaries. If EPP is enable, the parallel port can be set from 100H-3F8H on 8-byte boundaries. NCS = 0 and A10 = 0 are required to access the parallel port when in compatible, bi-directional, or EPP modes. A10 is active in ECP mode.

PRTAD7-PRTAD0 (Bit 7-bit 0): match A[9:2]. Bit 7 = 0 and bit 6 = 0 disable this decode.

### 8.2.28 Configuration Register 24 (CR24)

When the device is in Extended Function mode and EFIR is 24H, the CR24 register can be accessed through EFDR. Default = FEH if CR16 bit 2 = 1; default = 00H if CR16 bit 2 = 0. The bit definitions are as follows:

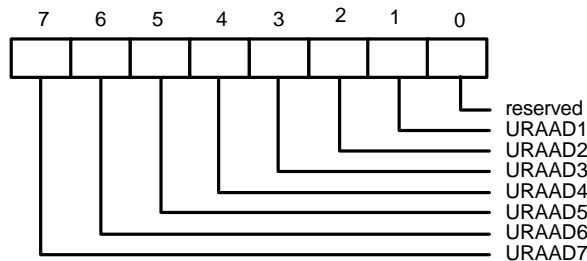

This register is used to select the base address of the UART A from 100H-3F8H on 8-byte boundaries. NCS = 0 and A10 = 0 are required to access the UART A registers. A[2:0] are don't-care conditions.

URAAD7-URAAD1 (Bit 7-bit 1): match A[9:3]. Bit 7 = 0 and bit 6 = 0 disable this decode.

Bit 0: Reserved, fixed at zero.

### 8.2.29 Configuration Register 25 (CR25)

When the device is in Extended Function mode and EFIR is 25H, the CR25 register can be accessed through EFDR. Default = BEH if CR16 bit 2 = 1; default = 00H if CR16 bit 2 = 0. The bit definitions are as follows:

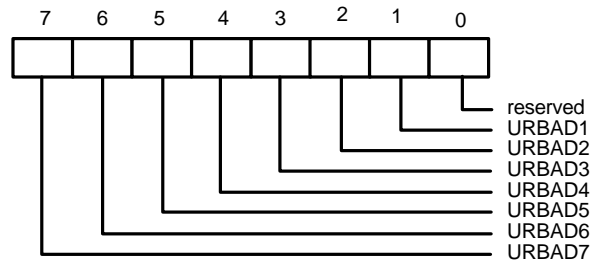

This register is used to select the base address of the UART B from 100H-3F8H on 8-byte boundaries. NCS = 0 and A10 = 0 are required to access the UART B registers. A[2:0] are don't-care conditions.

URBAD7-URBAD1 (Bit 7-bit 1): match A[9:3]. Bit 7 = 0 and bit 6 = 0 disable this decode.

Bit 0: Reserved, fixed at zero.

### 8.2.30 Configuration Register 26 (CR26)

When the device is in Extended Function mode and EFIR is 26H, the CR26 register can be accessed through EFDR. Default = 23H if CR16 bit 2 = 1; default = 00H if CR16 bit 2 = 0. The bit definitions are as follows:

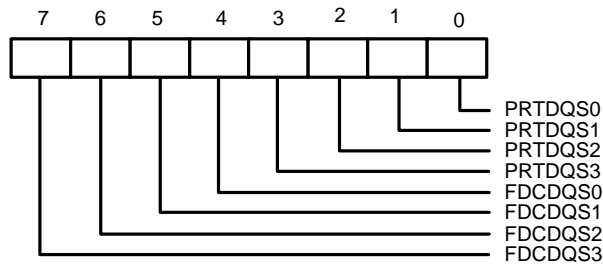

FDCDQS3-FDCDQS0 (Bit 7-bit 4): Allocate DMA resource for FDC.

PRTDQS3-PRTDQS0 (Bit 3-bit 0): Allocate DMA resource for PRT.

Bit 7- bit4, Bit 3 - bit 0	DMA selected
0000	None
0001	DMA_A
0010	DMA_B
0011	DMA_C

### 8.2.31 Configuration Register 27 (CR27)

When the device is in Extended Function mode and EFIR is 27, the CR27 register can be accessed through EFDR. Default = 05H if CR6 bit 2 = 1; default = 00H if CR16 bit 2 = 0. The bit definitions are as follows:

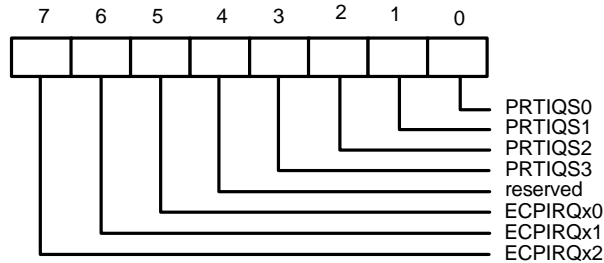

ECPIRQx2-ECPIRQx0 (Bit7-bit 5): These bits are configurable equivalents to bit[5:3] of cnfgB register in ECP mode, except that cnfgB[5:3] are read-only bits. They indicate the IRQ resource assigned for the ECP printer port. It is the software designer's responsibility to ensure that CR27[7:5] and CR27[3:0] are consistent. For example, CR27[7:5] should be filled with 001 (select IRQ 7) if CR27[3:0] are to be programmed as 0101 (select IRQ\_E) while IRQ\_E is connected to IRQ 7.

CR27[7:5]	IRQ resource
000	reflect other IRQ resources selected by CR27[3:0] (default)
001	IRQ 7
010	IRQ 9
011	IRQ 10
100	IRQ 11
101	IRQ 14
110	IRQ 15
111	IRQ 5

Bit 4: Reserved.

PRTIQS3-PRTIQS0 (Bit 3-bit 0): Select IRQ resource for the parallel port. Any unselected IRQ pin is in tri-state.

CR27[3:0]	select IRQ pin
0000	None
0001	IRQ_A
0010	IRQ_B
0011	IRQ_C
0100	IRQ_D
0101	IRQ_E
0110	IRQ_F
0111	IRQ_G
1000	IRQ_H

While in the Serial IRQ mode (IRQMODS=1, CR31 bit2), the above selection is invalid and all the IRQ signal pins, from IRQ\_A to IRQ\_H, are in tri-state. The parallel port IRQ is dedicated to the SERIRQ pin. For the host controller to correctly sample the parallel port IRQ, the parallel port IRQ should be programmed to appear in one of IRQ/Data Frame sampling periods.

In Serial IRQ mode, the definition of PRTIQS3-PRTIQS0 (bit 3-bit 0) is as follows:

PRTIQS3-PRTIQS0 (Bit 3-bit 0): Select the IRQ/Data Frame sampling period on the SERIRQ pin.

CR27[3:0]	IRQ/Data Frame Period
0000	None
0001	IRQ1
0010	Reserved for $\overline{\text{SMI}}$
0011	IRQ3
0100	IRQ4
0101	IRQ5
0110	IRQ6
0111	IRQ7
1000	IRQ8
1001	IRQ9
1010	IRQ10
1011	IRQ11
1100	IRQ12
1101	IRQ13
1110	IRQ14
1111	IRQ15

### 8.2.32 Configuration Register 28 (CR28)

When the device is in Extended Function mode and EFIR is 28, the CR28 register can be accessed through EFDR. Default = 43H if CR6 bit 2 = 1; default = 00H if CR16 bit 2 = 0. The bit definitions are as follows:

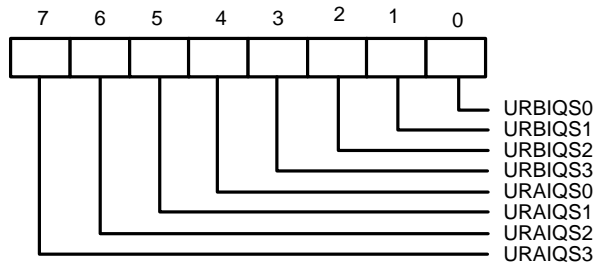

URAIQS3-URAIQS0 (Bit 7-bit 4): Allocate interrupt resource for UART A.

URBIQS3-URBIQS0 (Bit 3-bit 0): Allocate interrupt resource for UART B.

### 8.2.33 Configuration Register 29 (CR29)

When the device is in Extended Function mode and EFIR is 29, the CR29 register can be accessed through EFDR. Default = 62H if CR6 bit 2 = 1; default = 00H if CR16 bit 2 = 0. The bit definitions are as follows:

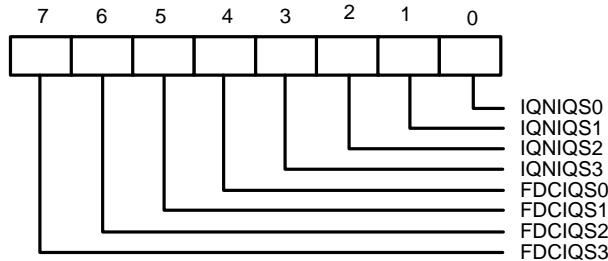

FDCIQS3-FDCIQS0 (Bit 7-bit 4): Allocate interrupt resource for FDC.

IQNIQS3-IQNIQS0 (Bit 3-bit 0): Allocate interrupt resource for IRQIN.

### 8.2.34 Configuration Registers (CR2A)

When the device is in Extended Function mode and EFIR is 2AH, the CR2A register can be accessed through EFDR. This register default value is 00<sub>16</sub>. The bit definitions are as follows:

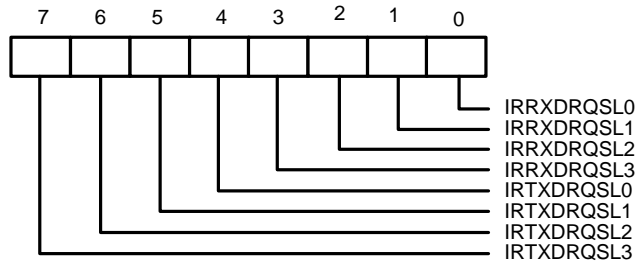

IRTXDRQSL (bit 7-bit 4): Transmitter DMA channel A through D selection when high speed infrared (FIR/MIR) is used and enable DMA channel. Note that these bits is used in two DMA channels.

IRRXDRQSL(bit 3-bit 0): Receiver or Transmitter DMA channel A through selection when high speed infrared (FIR/MIR) is used and enable DMA channel. Note that these bits act as RX DMA channel selection if two DMA channel is used, or act as RX/TX DMA channel selection if single DMA channel is used.

### 8.2.35 Configuration Registers (CR2B)

When the device is in Extended Function mode and EFIR is 2BH, the CR2B register can be accessed through EFDR. This register default value is 00<sub>16</sub>. The bit definitions are as follows:

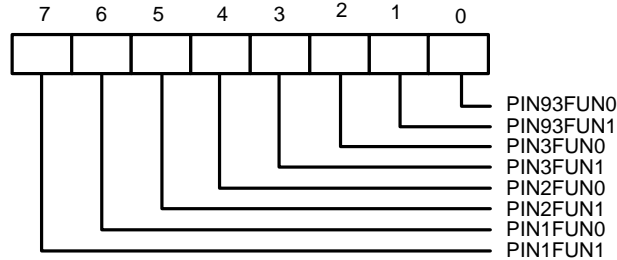

Bit 7~6: PIN1FUN1~0 - Pin 1 function select.

IRQMODS <sup>*</sup>	PIN1FUN1	PIN1FUN0	Pin 1
0	0	0	IRQ_G
0	0	1	Reserved
0	1	0	DRQ_D
0	1	1	IRSL2
1	X	X	PCICLK

\* Note that: IRQMODS is defined in CR31.Bit2, that is, the IRQ mode selection bit.

Bit 5-4: PIN2FUN1~0 - Pin 2 function select.

PIN2FUN1	PIN2FUN0	Pin 2
0	0	nCS
0	1	A11
1	0	Reserved
1	1	Reserved

Bit 3-2: PIN3FUN1~0 - Pin 3 function select.

PIN3FUN1	PIN3FUN0	Pin 3
0	0	PDCIN
0	1	nDACK_D
1	0	IRSL1
1	1	IRRXH/IRSL0

Bit 1-0: PIN93FUN1~0 - Pin 93 function select.

ENPNF(CR16.Bit7)	PIN93FUN1	PIN93FUN0	Pin 93
0	0	0	IRQIN
0	0	1	DRQ_D
0	1	0	IRSL2
0	1	1	IRRXH/IRSL0
1	X	X	PNF

### 8.2.36 Configuration Registers (CR2C)

When the device is in Extended Function mode and EFIR is 2CH, the CR2C register can be accessed through EFDR. This register default value is 10<sub>16</sub>. The bit definitions are as follows:

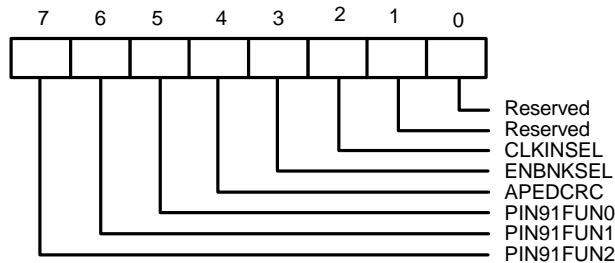

Bit 7-2 : PIN91FUN2~0 - Pin 91 function select.

IRQMODS*	PIN91FUN2	PIN91FUN1	PIN91FUN0	Pin 91
0	0	0	0	IRQ_H
0	0	0	1	Reserved
0	0	1	0	IRSL2
0	0	1	1	Reserved
0	1	0	0	DACK_D
1	X	X	X	SERIRQ

\* Note that the bit IRQMODS is defined in CR31.Bit2, that is, a IRQ mode selection.

Note: The IRSL0/IRRXH selection is determined by Bit 5(IRSL0 Mode selection) of Register7 of Bank7. When setting Bit 5 to logical 1, IRSL0 is selected; When setting Bit 5 to logical 0, IRRXH is selected.

Bit 4 : APEDCRC - Append CRC to receiver when a frame is end.

= 0 No append hardware CRC value as data in FIR/MIR mode

= 1 Append hardware CRC value as data in FIR/MIR mode

- Bit 3 :ENBNKSEL - Bank select enable
  - = 0 Disable UART B bank selection
  - = 1 Enable UART B bank selection
- Bit 2 :CLKINSEL - Clock input selection
  - = 0 The clock on pin CLKIN is 24 MHz
  - = 1 The clock on pin CLKIN is 48MHz
- Bit 1, Bit 0: Reserved

**8.2.37 Configuration Registers (CR2D)**

When the device is in Extended Function mode and EFIR is 2D<sub>16</sub>, the CR2D register can be accessed through EFDR. This register default value is 00<sub>16</sub>. The bit definitions are as follows:

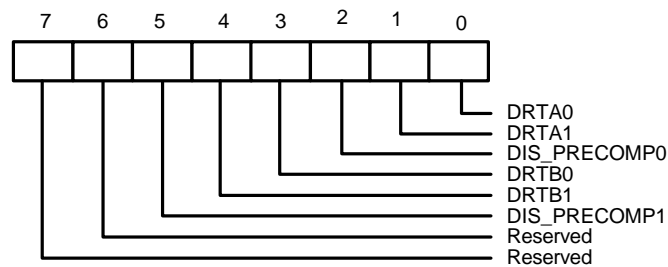

This register controls the data rate selection for FDC. It also controls if precompensation is enabled.

DRTA1, DRTA0 (bit 1 - bit 0):

These two bits combining with data rate selection bits in Date Rate Register select the operational data rate for FDD A as follows:

Drive Rate Table		Data Rate		operational data rate	
DRTA1	DRTA0	DRATE1	DRATE0	MFM	FM
0	0	1	1	1M	---
0	0	0	0	500K	250K
0	0	0	1	300K	150K
0	0	1	0	250K	125K
0	1	1	1	1M	---
0	1	0	0	500K	250K
0	1	0	1	500K	250K
0	1	1	0	250K	125K
1	0	1	1	1M	---
1	0	0	0	500K	250K
1	0	0	1	2M	---
1	0	1	0	250K	125K

DIS\_PRECOMP0 (bit 2):

This bit controls if precompensation is enabled for FDD A.

- 0 enable precompensation for FDD A
- 1 disable precompensation for FDD A

DRTB1, DRTB0 (bit 4 - bit 3):

These two bits combining with data rate selection bits in Date Rate Register select the operational data rate for FDD B as shown in last table.

DIS\_PRECOMP1 (bit 5):

This bit controls if precompensation is enabled for FDD B.

- 0 enable precompensation for FDD B
- 1 disable precompensation for FDD B

Bit 7 - bit 6: Reserved.

**8.2.38 Configuration Register 2E (CR2E), default = 2eH**

When the device is in Extended Function mode and EFIR is 2eH, the CR2E register can be accessed through EFDR. The bit definitions are as follows:

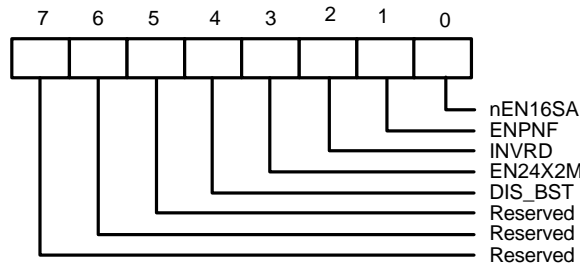

ENPNF (Bit 0):

- 0 Disable Printer Not Floppy function. (Default)
- 1 Enable Printer Not Floppy function.

nEN16SA (Bit 1):

- 0 Enable 16-bit address decoder in the ISA bus. If the function of full ISA address decoder is used, the device of COM B will be Changed to SIR/FIR function automatically.
- 1 Disable 16-bit address decoder in the ISA bus.

INVRD (Bit 2):

- 0 Disable inverting  $\overline{RDATA}$  from floppy disk input signal. (Default)
- 1 Enable inverting  $\overline{RDATA}$  from floppy disk input signal.

EN24MX2:

- 0 Using internal circuit type *one* to generate 48M Hz when CLKIN is 24M Hz. (Default)
- 1 Using internal circuit type *two* to generate 48M Hz when CLKIN is 24M Hz.

DIS\_BST(Bit3): Disable FDC DMA Burst Mode.

- 0 Enable FDC burst mode. (Default)
- 1 Disable FDC burst mode.

### 8.2.39 Configuration Register 31 (CR31), default=00H

When the device is in Extended Function mode and EFIR is 31H, the CR31 register can be accessed through EFDR. The bit definitions are as follows:

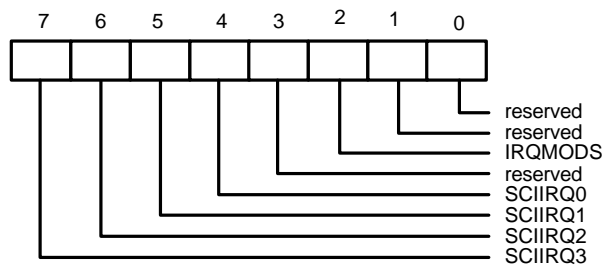

SCIIRQ3 ~ SCIIRQ0 (Bit 7 - bit 4):

The four bits select one IRQ pin for the SCI signal except for dedicated SCI signal output pin. Any unselected pin is in tri-state.

CR31[7:4]	Mapped IRQ pin
0000	None (default)
0001	IRQ_A
0010	IRQ_B
0011	IRQ_C
0100	IRQ_D
0101	IRQ_E
0110	IRQ_F
0111	IRQ_G
1000	IRQ_H

While in the Serial IRQ mode (IRQMODS=1, CR31 bit 2), the above selection is invalid and all the IRQ signal pins, from IRQ\_A to IRQ\_H, are all in tri-state. The SCI interrupt output is dedicated to the SERIRQ pin. For the host controller to correctly sample the SCI interrupt, the SCI interrupt should be programmed to appear in one of IRQ/Data Frame sampling periods.

**In Serial IRQ mode, the definition of SCIIQS3-SCIIQS0 (bit 7-bit 4) is as follows:**

**SCIIQS3-SCIIQS0 (bit 7-bit 4): Select the IRQ/Data sampling period on the SERIRQ pin.**

CR27[7:4]	IRQ/Data Frame Period
0000	None
0001	IRQ1
0010	Reserved for $\overline{\text{SMI}}$
0011	IRQ3
0100	IRQ4
0101	IRQ5
0110	IRQ6
0111	IRQ7
1000	IRQ8
1001	IRQ9
1010	IRQ10
1011	IRQ11
1100	IRQ12
1101	IRQ13
1110	IRQ14
1111	IRQ15

Bit 3: Reserved.

IRQMODS (Bit 2):

IRQ mode selection. The W83877ATF supports: (1) legacy ISA IRQ mode or ISA IRQ sharing mode. (2) Serial IRQ mode used in the PCI bus. In the legacy ISA IRQ sharing mode, the selected IRQ pin for the device's IRQ is defined in the configuration registers CR27 - CR29. In the ISA IRQ sharing mode, configuration register CR18 indicates which IRQ pin is in the IRQ sharing mode.

- 0: legacy ISA IRQ mode or ISA IRQ sharing mode.(default)
- 1: Serial IRQ mode used in PCI bus.

Bit 1 - bit 0: Reserved.

**8.2.40 Configuration Register 32 (CR32), default=00H**

When the device is in Extended Function mode and EFIR is 32H, the CR32 register can be accessed through EFDR. The bit definitions are as follows:

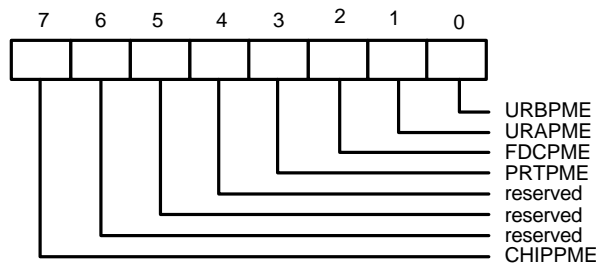

CHIPPME (Bit 7): W83877ATF chip power management enable.

0	disable the ACPI/Legacy and the auto power management functions.
1	enable the ACPI/Legacy and the auto power management functions.

Bit 6 - bit 4: Reserved.

P RTPME (Bit 3): Printer port power management enable.

0	disable the auto power management function.
1	enable the auto power management function, if this bit and CHIPPME(CR32 bit 7) are both set to 1.

FDCPME (Bit 2): FDC power management enable.

0	disable the auto power management function.
1	enable the auto power management function, if this bit and CHIPPME(CR32 bit 7) are both set to 1.

URAPME (Bit 1): UART A power management enable.

0	disable and the auto power management function.
1	enable auto power management function, if this bit and CHIPPME(CR32 bit 7) are both set to 1.

URBPME (Bit 0): UART B power management enable.

0	disable the auto power management functions.
1	enable the auto power management function, if this bit and CHIPPME(CR32 bit 7) are both set to 1.

**8.2.41 Configuration Register 33 (CR33), default=00H**

When the device is in Extended Function mode and EFIR is 33H, the CR33 register can be accessed through EFDR. The bit definitions are as follows:

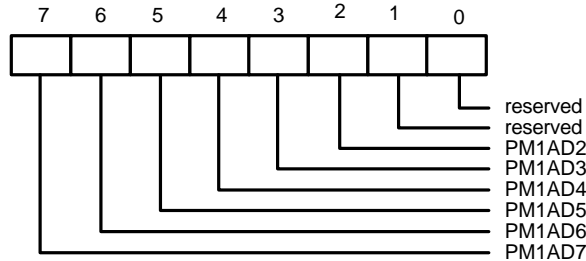

PM1AD7 - PM1AD2 (Bit 7 - bit 2): Base address of the power management register block PM1.

This address is the base address of PM1a\_EVT\_BLK in the ACPI specification. The based address should range from 01,0000,0000<sub>b</sub> to 11,1111,0000<sub>b</sub> ,i.e., 100H ~ 3F0H, where bit 1 and bit 0 of the base address should be set to 0 and the based address is in the 16-byte alignment. Note that the based address of PM1a\_CNT\_BLK is equal to PM1a\_EVT\_BLK + 4, and PM\_TMR\_BLK is equal to PM1a\_EVT\_BLK + 8.

Bit 1 - bit 0: Reserved, fixed at 0.

**8.2.42 Configuration Register 34 (CR34), default=00H**

When the device is in Extended Function mode and EFIR is 34H, the CR34 register can be accessed through EFDR. The bit definitions are as follows:

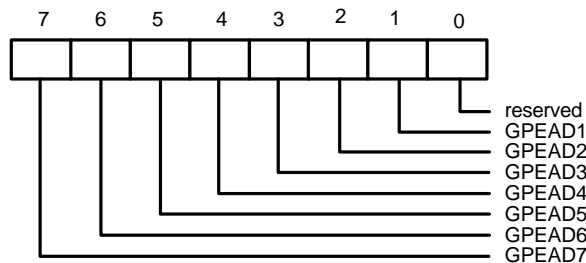

GPEAD7 - GPEAD1 (Bit7 - bit 1): Base address of the power management register block GPE.

This address is the base address of GPE0\_BLK in the ACPI specification. The base address should range from 01,0000,0000<sub>b</sub> to 11,1111,1000<sub>b</sub> ,i.e., 100H ~ 3F8H, where bit 0 of the base address should be set to 0 and the base address is in the 8-byte alignment. Note that the base address of GPE1\_BLK is GPE0\_BLK + 4.

Bit 0: Reserved, fixed at 0.

**8.2.43 Configuration Register 35 (CR35), default=00H**

When the device is in Extended Function mode and EFIR is 35H, the CR35 register can be accessed through EFDR. The bit definitions are as follows:

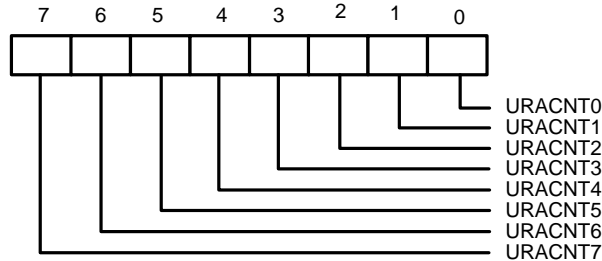

URACNT7 - URACNT0 (Bit 7 - bit 0): UART A idle timer count.

This register is used to specify the initial value of UART A idle timer. Once UART A enters the working state (that is, after any access to this device, any IRQ, and any external input), the power down machine of UART A reloads this count value and the idle timer counts down. When the timer counts down to zero, UART A enters the power down state ,i.e., sleeping state. If this register is set to 00H, the power down function will be invalid. The time resolution of this value is minute or second, which is defined by the TMIN\_SEL bit of the CR3A. Note that (1). This register is valid only when the power management function of UART A is enabled, that is, CHIPPME=1 (CR32 bit 7) and URAPME=1 (CR32 bit 1), (2). If the register is set to 00H, UART A will remain in the current state (working or sleeping).

**8.2.44 Configuration Register 36 (CR36), default=00H**

When the device is in Extended Function mode and EFIR is 36H, the CR36 register can be accessed through EFDR. The bit definitions are as follows:

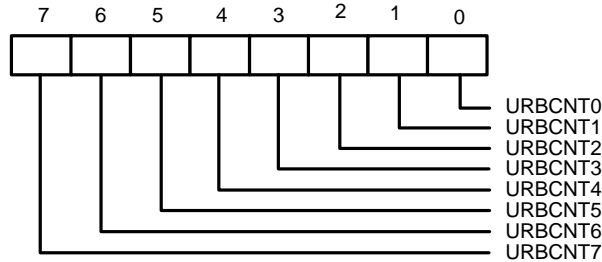

URBCNT7 - URBCNT0 (Bit 7 - bit 0): UART B idle timer count.

This register is used to specify the initial value of UART B idle timer. Once UART B enters the working state (that is, after any access to this device, any IRQ, and any external input), the power down machine of UART B reloads this count value and the idle timer counts down. When the timer counts down to zero, UART B enters the power down state ,i.e., sleeping state. If this register is set to 00H, the power down function will be invalid. The time resolution of this value is minute or second, which is defined by the TMIN\_SEL bit of CR3A. Note that (1). This register is valid only when the power management function of UART B is enabled, that is, CHIPPME=1 (CR32 bit 7) and URBPME=1 (CR32 bit 0), (2). If the register is set to 00H, UART B will remain in the current state (working or sleeping).

**8.2.45 Configuration Register 37 (CR37), default=00H**

When the device is in Extended Function mode and EFIR is 37H, the CR37 register can be accessed through EFDR. The bit definitions are as follows:

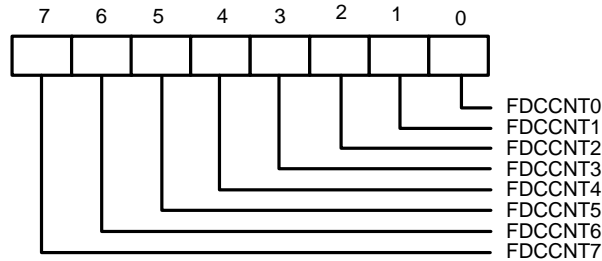

FDCCNT7 - FDCCNT0 (Bit 7 - bit 0): FDC idle timer count.

This register is used to specify the initial value of FDC idle timer. Once FDC enters the working state (that is, after any access to this device, any IRQ, and any external input), the power down machine of FDC reloads this count value and the idle timer counts down. When the timer counts down to zero, FDC enters the power down state ,i.e., sleeping state. If this register is set to 00H, the power down function will be invalid. The time resolution of this value is minute or second, which is defined by the TMIN\_SEL bit of the CR3A. Note that (1). This register is valid only when the power management function of FDC is enabled, that is, CHIPPME=1 (CR32 bit 7) and FDCPME=1 (CR32 bit 2), (2). If the register is set to 00H, FDC will remain in the current state\_(working or sleeping).

**8.2.46 Configuration Register 38 (CR38), default=00H**

When the device is in Extended Function mode and EFIR is 38H, the CR38 register can be accessed through EFDR. The bit definitions are as follows:

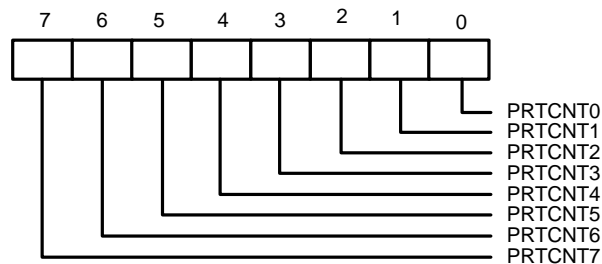

PRTCNT7 - PRTCNT0 (Bit 7 - bit 0): printer port idle timer count.

This register is used to specify the initial value of the printer port idle timer. Once the printer port enters the working state (that is, after any access to this device, any IRQ, and any external input), the power down machine of the printer port reloads this count value and this idle timer counts down. When the timer counts down to zero, printer port enters the power down state ,i.e., sleeping state. If this register is set to 00H, the power down function will be invalid. The time resolution of this value is minute or second, which is defined by the TMIN\_SEL bit of CR3A. Note that (1). This register is valid only when the power management function of the printer port is enabled, that is, CHIPPME=1 (CR32 bit 7) and PRTPME=1 (CR32 bit 3), (2). If the register is set to 00H, the printer port will remain in the current state\_(working or sleeping).

**8.2.47 Configuration Register (CR39), default=00H**

When the device is in Extended Function mode and EFIR is 39H, the CR39 register can be accessed through EFDR. The bit definitions are as follows:

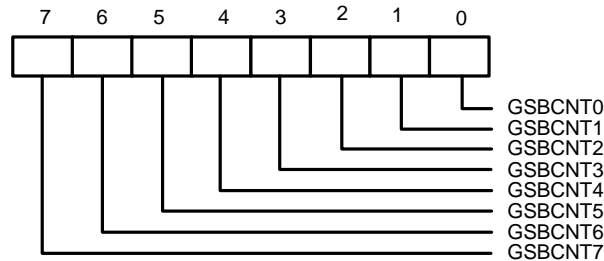

GSBCNT7 - GSBCNT0 (Bit 7 - bit 0): global stand-by idle timer count.

Once all devices of the chip (including UART A, UART B, FDC and the printer port) are all in the power down state, the power down machine of W83877ATF chip loads this register value and counts down. When the timer counts to zero, the whole chip enters the power down state, i.e., sleeping state. If this register is set to 0, the power down function will be invalid. The time resolution of this register value is minute or second, which is defined by the TMIN\_SEL bit of CR3A. Note that (1). This register is valid when the CHIPPME = 1 (CR32 bit 7), and (2) If the register is set to 00H, W83877ATF chip will remain in the current state.(working or sleeping).

**8.2.48 Configuration Register 3A (CR3A), default=00H**

When the device is in Extended Function mode and EFIR is 3AH, the CR3A register can be accessed through EFDR. The bit definitions are as follows:

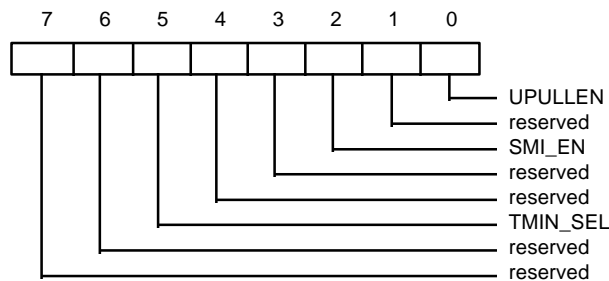

Bit 7 - bit 6 : Reserved, fixed at 0.

TMIN\_SEL (Bit 5): Time resolution of the auto power machines of all devices.

CR35 to CR39 store the initial counts of the devices.

0	one second
1	one minute

Bit 4 - bit 2: Reserved, fixed at 0.

SMI\_EN (Bit 2): SMI output pin enable.

While an SMI event is raised on the output of the SMI logic, this bit determines whether the SMI interrupt is generated on the SMI output  $\overline{\text{SMI}}$  pin and on the Serial IRQ IRQSER pin while in Serial IRQ mode.

0	disable
1	enable

Bit 1:Reserved.

UPULLEN (Bit 0): Enable the pull up of IRQSER pin in Serial IRQ mode.

0	disable the pull up of IRQSER pin.
1	enable the pull up of IRQSER pin.

**8.2.49 Configuration Register 3B (CR3B), default=00H**

Reserved for testing. Should be kept all 0's.

**8.2.50 Configuration Register 40 (CR40), default=00H**

When the device is in Extended Function mode and EFIR is 40H, the CR40 register can be accessed through EFDR. The bit definitions are as follows:

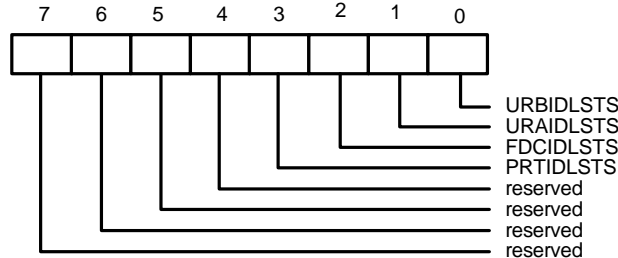

Bit 7 - bit 4 : Reserved, fixed at 0.

Bit 3 - bit 0 : Devices' idle status.

These bits indicate that the individual device's idle timer expires due to no I/O access, IRQ, and external input to the device respectively. These 4 bits are controlled by the printer port, FDC, UART A, and UART B power down machines individually. The bits are set/cleared by W83877ATF automatically. Writing a 1 can also clear this bit, and writing a 0 has no effect.

PRTIDLSTS (Bit 3): printer port idle status.

0	printer port is now in the working state.
1	printer port is now in the sleeping state due to no printer port access, IRQ, DMA acknowledge, and no transition on $\overline{\text{BUSY}}$ , $\overline{\text{ACK}}$ , PE, SLCT, and $\overline{\text{ERR}}$ pins.

FDCIDLSTS (Bit 2): FDC idle status.

0	FDC is now in the working state.
1	FDC is now in the sleeping state due to no FDC access, no IRQ, no DMA acknowledge, and no enabling of the motor enable bits in the DOR register.

URAILDSTS (Bit 1): UART A idle status.

0	UART A is now in the working state.
1	UART A is now in the sleeping state due to no UART A access, no IRQ, the receiver is now waiting for a start bit, the transmitter shift register is now empty, and no transition on MODEM control input lines.

URBIDLSTS (Bit 0): UART B idle status.

0	UART B is now in the working state.
1	UART B is now in the sleeping state due to no UART B access, no IRQ, the receiver is now waiting for a start bit, the transmitter shift register is now empty, and no transition on MODEM control input lines.

**8.2.51 Configuration Register 41 (CR41), default=00H**

When the device is in Extended Function mode and EFIR is 41H, the CR41 register can be accessed through EFDR. The bit definitions are as follows:

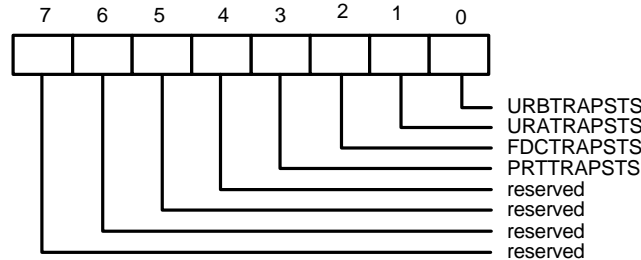

Bit 7 - bit 4 : Reserved, fixed at 0.

Bit 3 - bit 0 : Devices' \_trap status.

These bits indicate that the individual device wakes up due to any I/O access, IRQ, and external input to the device respectively. The device's idle timer reloads the initial count value from CR35-CR39, depending on which device wakes up. These 4 bits are controlled by the printer port, FDC, UART A, and UART B power down machines individually. The bits are set/cleared by W83877ATF automatically. Writing a 1 can also clear this bit, and writing a 0 has no effect.

PRTTRAPSTS (Bit 3): printer port trap status.

0	the printer port is now in the sleeping state.
1	the printer port is now in the working state due to any printer port access, any IRQ, any DMA acknowledge, and any transition on BUSY, $\overline{ACK}$ , PE, SLCT, and $\overline{ERR}$ pins.

FDCTRAPSTS (Bit 2): FDC trap status.

0	FDC is now in the sleeping state.
1	FDC is now in the working state due to any FDC access, any IRQ, any DMA acknowledge, and any enabling of the motor enable bits in the DOR register.

URATRAPSTS (Bit 1): UART A trap status.

0	UART A is now in the sleeping state.
1	UART A is now in the working state due to any UART A access, any IRQ, the receiver begins receiving a start bit, the transmitter shift register begins transmitting a start bit, and any transition on MODEM control input lines.

URBTRAPSTS (Bit 0): UART B trap status.

0	UART B is now in the sleeping state.
1	UART B is now in the working state due to any UART B access, any IRQ, the receiver begins receiving a start bit, the transmitter shift register begins transmitting a start bit, and any transition on MODEM control input lines.

**8.2.52 Configuration Register 42 (CR42), default=N/A**

When the device is in Extended Function mode and EFIR is 42H, the CR42 register can be accessed through EFDR. The bit definitions are as follows:

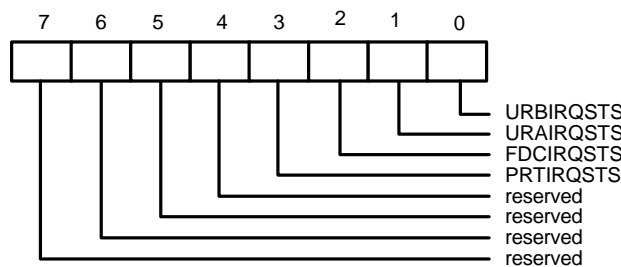

Bit 7 - bit 4 : Reserved, fixed at 0.

Bit 3 - bit 0 : Device's IRQ status .

These bits indicate the IRQ pin status of the individual device. The device's IRQ status bit is set or cleared at their source device; writing a 1 or 0 has no effect.

PRTIRQSTS (Bit 3) : printer port IRQ status. While the IRQ type of printer port is edge trigger-type, this bit will set and reset immediately. As the software reads this bit, it indicates low level. The software must read the IRQ status bit in the printer port device register to correctly identify whether the printer port IRQ occurs.

FDCIRQSTS (Bit 2) : FDC IRQ status.

URAIQSTS (Bit 1) : UART A IRQ status.

URBIQSTS (Bit 0) : UART B IRQ status.

**8.2.53 Configuration Register 43 (CR43), default=00H**

When the device is in Extended Function mode and EFIR is 43H, the CR43 register can be accessed through EFDR. This register is reserved.

**8.2.54 Configuration Register 44 (CR44), default=00H**

When the device is in Extended Function mode and EFIR is 44H, the CR44 register can be accessed through EFDR. This register is reserved.

**8.2.55 Configuration Register 45 (CR45), default=00H**

When the device is in Extended Function mode and EFIR is 45H, the CR45 register can be accessed through EFDR. The bit definitions are as follows:

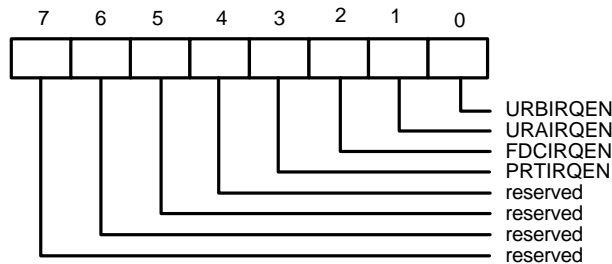

Bit 7 - bit 4 : Reserved, fixed at 0.

Bit 3 - bit 0 : Enable bits of the SMI generation due to the device's IRQ.

These bits enable the generation of an SMI interrupt due to any IRQ of the devices respectively. These 4 bits control the printer port, FDC, UART A, and UART B SMI logics individually. The SMI logic output for the IRQs is as follows:

SMI logic output = (URBIRQEN and URBIRQSTS) or (URAIIRQEN and URAIRQSTS) or (FDCIRQEN and FDCIRQSTS) or (PRTIRQEN and PRTIRQSTS)

If any device's IRQ is raised, the corresponding IRQ status bit in CR42 is set. If the device's enable bit is set and SMI\_EN(in CR3A) and CHIPPME(in CR32) is both set, then SMI interrupt occurs on the SMI output pin.

PRTIRQEN (Bit 3):

0	disable the generation of an SMI interrupt due to the printer port's IRQ.
1	enable the generation of an SMI interrupt due to the printer port's IRQ.

FDCIRQEN (Bit 2):

0	disable the generation of an SMI interrupt due to the FDC's IRQ.
1	enable the generation of an SMI interrupt due to the FDC's IRQ.

URAIIRQEN (Bit 1):

0	disable the generation of an SMI interrupt due to the UART A's IRQ.
1	enable the generation of an SMI interrupt due to the UART A's IRQ.

URBIRQEN (Bit 0):

0	disable the generation of an SMI interrupt due to the UART B's IRQ.
1	enable the generation of an SMI interrupt due to the UART B's IRQ.

**8.2.56 Bit Map Configuration Registers**
**Table 8-1: Bit Map of Configuration Registers**

Register	Power-on Reset Value	D7	D6	D5	D4	D3	D2	D1	D0
CR0	0000 0000	0	0	0	0	PRTMODS1	PRTMODS0	0	IPD
CR1	0000 0000	ABCHG	0	0	0	0	0	0	0
CR2	0000 0000	0	0	0	0	0	0	0	0
CR3	0011 0000	0	0	EPPVER	0	0	0	SUAMIDI	SUBMIDI
CR4	0000 0000	PRTPWD	0	URAPWD	URBPWD	PRTRRI	0	URATRI	URBTRI
CR5	0000 0000	0	0	0	0	ECPFTHR3	ECPFTHR2	ECPFTHR1	ECPFTHR0
CR6	0000 0000	0	0	SEL4FDD	FIPURDWN	FDCPWD	0	FDCTRI	0
CR7	0000 0000	FDD D T1	FDD D T0	FDD C T1	FDD C T0	FDD B T1	FDD B T0	FDD A T1	FDD A T0
CR8	0000 0000	0	0	DISFDDWR	SWWP	MEDIA 1	MEDIA 0	BOOT 1	BOOT 0
CR9	0000 1101	PRTMODS2	LOCKREG	EN3MODE	0	CHIP ID 3	CHIP ID 2	CHIP ID 1	CHIP ID 0
CRA	0000 0000	0	0	0	0	0	0	0	0
CRB	0000 1100	0	Tx4WC	Rx4WC	ENIFCHG	IDENT	MFM	INVERTZ	DRV2EN
CRC	0010 1000	TURA	TURB	HEFERE	0	URIRSEL	0	RX2INV	TX2INV
CRD	1010 0011	SIRTX1	SIRTX0	SIRRX1	SIRRX0	HDUPLX	IRMODE2	IRMODE1	IRMODE0
CR10	0000 0000	GIO0AD7	GIO0AD6	GIO0AD5	GIO0AD4	GIO0AD3	GIO0AD2	GIO0AD1	GIO0AD0
CR11	0000 0000	G0CADM1	G0CADM0	0	0	0	GIO0AD10	GIO0AD9	GIO0AD8
CR12	0000 0000	GIO1AD7	GIO1AD6	GIO1AD5	GIO1AD4	GIO1AD3	GIO1AD2	GIO1AD1	GIO1AD0
CR13	0000 0000	G1CADM1	G1CADM0	0	0	0	GIO1AD10	GIO1AD9	GIO1AD8
CR14	0000 0000	GIOP0MD2	GIOP0MD1	GIOP0MD0	GIO0CSH	GCS0IOR	GCS0IOW	GDA0OPI	GDA0IPI
CR15	0000 0000	GIOP1MD2	GIOP1MD1	GIOP1MD0	GIO1CSH	GCS1IOR	GCS1IOW	GDA1OPI	GDA1IPI
CR16	00ss 0s0s <sup>1</sup>	0	0	G1IQSEL	G0IQSEL	0	PNPCVS	0	HEFRAS
CR17	0000 0000	0	0	0	PRIRQOD	DSFDLGRQ	DSPLRGRQ	DSUALGRQ	DSUBLGRQ
CR18	0000 0000	SHARH	SHARG	SHARF	SHARE	SHARD	SHARC	SHARB	SHARA
CR19	0000 0000	0	0	0	0	0	0	FASTA	FASTB

Continued Table 8-1: Bit Map of Configuration Registers

CR20	1111 1100 <sup>2</sup>	FDCAD7	FDCAD6	FDCAD5	FDCAD4	FDCAD3	FDCAD2	0	0
CR23	1101 1110 <sup>2</sup>	PRTAD7	PRTAD6	PRTAD5	PRTAD4	PRTAD3	PRTAD2	PRTAD1	PRTAD0
CR24	1111 1110 <sup>2</sup>	URAAD7	URAAD6	URAAD5	URAAD4	URAAD3	URAAD2	URAAD1	0
CR25	1011 1110 <sup>2</sup>	URBAD7	URBAD6	URBAD5	URBAD4	URBAD3	URBAD2	URBAD1	0
CR26	0010 0011 <sup>2</sup>	FDCDQS3	FDCDQS2	FDCDQS1	FDCDQS0	PRTDQS3	PRTDQS2	PRTDQS1	PRTDQS0
CR27	0000 0101 <sup>2</sup>	ECPIRQx2	ECPIRQx1	ECPIRQx0	0	PRTIQS3	PRTIQS2	PRTIQS1	PRTIQS0
CR28	0100 0011 <sup>2</sup>	URAIQS3	URAIQS2	URAIQS1	URAIQS0	URBIQS3	URBIQS2	URBIQS1	URBIQS0
CR29	0110 0000 <sup>2</sup>	FDCIQS3	FDCIQS2	FDCIQS1	FDCIQS0	IQNIQS3	IQNIQS2	IQNIQS1	IQNIQS0
CR2A	0000 0000	IRTXDSL3	IRTXDSL2	IRTXDSL1	IRTXDSL0	IRRXDSL3	IRRXDSL2	IRRXDSL1	IRRXDSL0
CR2B	0000 0000	PIN1FUN1	PIN1FUN0	PIN2FUN1	PIN2FUN0	PIN3FUN1	PIN3FUN0	PIN93FUN1	PIN93FUN0
CR2C	0000 0000	PIN91FUN2	PIN91FUN1	PIN91FUN0	APEDCRC	ENBNKSL	CLKINSEL	0	0
CR2D	0000 0000	0	0	DIS-PRECOM1	DRTB 1	DRTB 0	DIS-PRECOM0	DRTA 1	DRTA 0
CR31	0000 0s00	SCIIRQ3	SCIIRQ2	SCIIRQ1	SCIIRQ0	0	IRQMODS	0	0
CR32	0000 0000	CHIPPME	0	0	0	PRTPME	FDCPME	URAPME	URBPME
CR33	0000 0000	PM1AD7	PM1AD6	PM1AD5	PM1AD4	PM1AD3	PM1AD2	0	0
CR34	0000 0000	GPEAD7	GPEAD6	GPEAD5	GPEAD4	GPEAD3	GPEAD2	GPEAD1	0
CR35	0000 0000	URACNT7	URACNT6	URACNT5	URACNT4	URACNT3	URACNT2	URACNT1	URACNT0
CR36	0000 0000	URBCNT7	URBCNT6	URBCNT5	URBCNT4	URBCNT3	URBCNT2	URBCNT1	URBCNT0
CR37	0000 0000	FDCCNT7	FDCCNT6	FDCCNT5	FDCCNT4	FDCCNT3	FDCCNT2	FDCCNT1	FDCCNT0
CR38	0000 0000	PRTCNT7	PRTCNT6	PRTCNT5	PRTCNT4	PRTCNT3	PRTCNT2	PRTCNT1	PRTCNT0
CR39	0000 0000	GSBCNT7	GSBCNT6	GSBCNT5	GSBCNT4	GSBCNT3	GSBCNT2	GSBCNT1	GSBCNT0
CR3A	0000 0000	0	0	TMIN_SEL	0	0	SMI_EN	0	UPULLEN
CR40	0000 0000	0	0	0	0	PRTIDLSTS	FDCIDLSTS	URAILDSTS	URBIDLSTS
CR41	0000 0000	0	0	0	0	PRTRAPSTS	FDCTRAPSTS	URATRAPSTS	URBTRAPSTS
CR42	0000 0000	0	0	0	0	PRTIRQSTS	FDCIRQSTS	URAIQSTS	URBIQSTS
CR43	0000 0000	0	0	0	0	0	0	0	0
CR44	0000 0000	0	0	0	0	0	0	0	0
CR45	0000 0000	0	0	0	0	PRTIRQEN	FDCIRQEN	URAIQEN	URBIQEN

**Notes:**

1. 's' means its value depends on corresponding power-on setting pin.
2. These default values are valid when CR16 bit 2 is 1 during power-on reset; They will be all 0's if CR16 bit 2 is 0.

### 8.3 ACPI Registers Features

W83877ATF supports both the ACPI and legacy power managements. The switch logic of the power management block generates an SMI interrupt in the legacy mode and an SCI interrupt in the ACPI mode. For the legacy mode, the SMI\_EN bit is used. If it is set, it routes the power management events from the SMI interrupt logic to the SMI output pin. For the ACPI mode, the SCI\_EN bit is used. If it is set, it routes the power management events to the SCI interrupt logic. The SMI\_EN bit is located in the CR3A register and the SCI\_EN bit is located in the PM1 register block. See the following figure for an illustration.

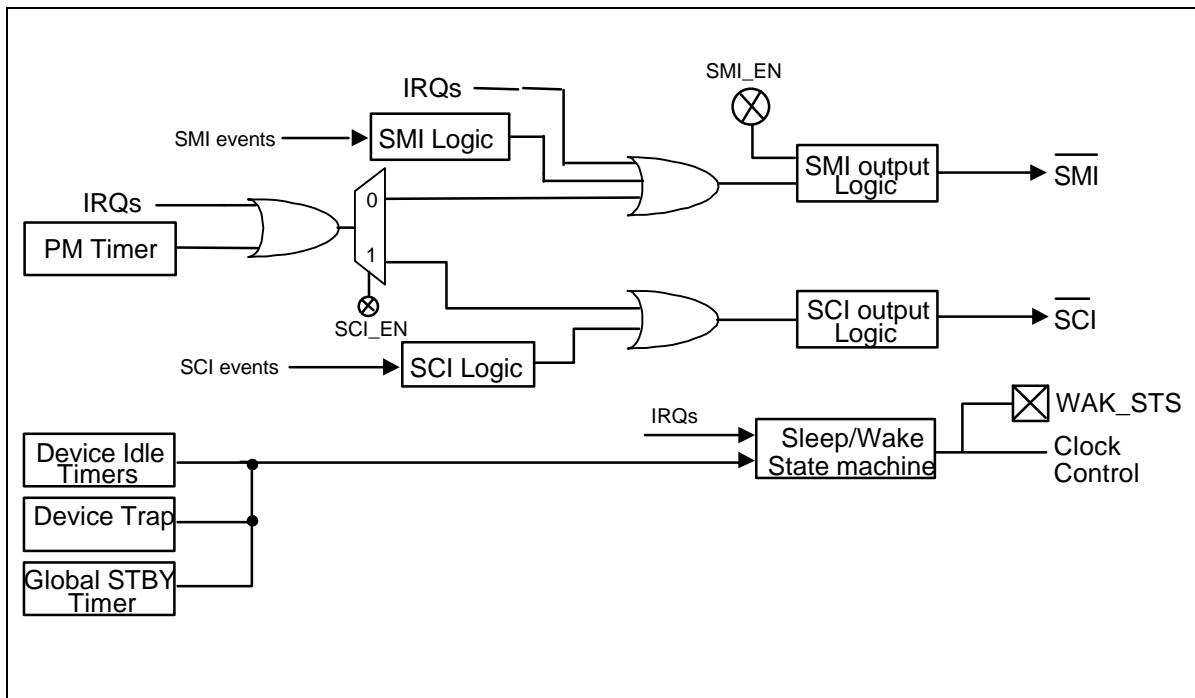

The SMI interrupt is routed to pin  $\overline{\text{SMI}}$ , which is dedicated for the SMI interrupt output. Another way to output the SMI interrupt is to route to pin IRQSER, which is the signal pin in the Serial IRQ mode. The SCI interrupt is routed to pin  $\overline{\text{SCI}}$ , which is dedicated for the SCI function. The other way to output the SCI interrupt is to route to one interrupt request signal pin IRQA~H, which is selected through CR31 bit[7:4]. Another way is output the SCI interrupt is to route to pin IRQSER.

### 8.3.1 SMI to SCI/SCI to SMI and Bus Master

For the process of generating an interrupt from SMI to SCI or from SCI to SMI, see the following figure for an illustration.

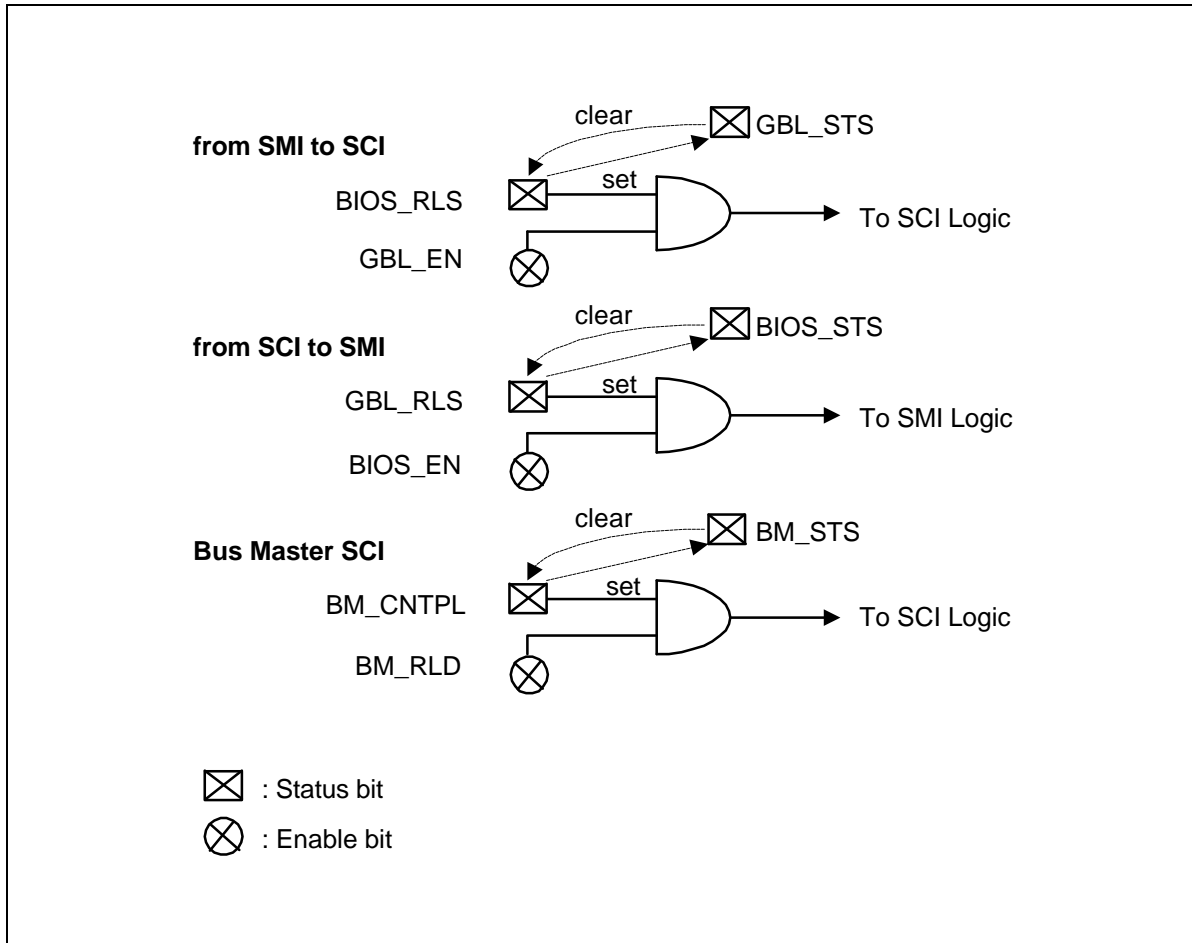

For the BIOS software to raise an event to the ACPI software, BIOS\_RLS, GBL\_EN, and GBL\_STS bits are involved. GBL\_EN is the enable bit and the GBL\_STS is the status bit. Both are controlled by the ACPI software. If BIOS\_RLS is set by the BIOS software and GBL\_EN is set by the ACPI software, an SCI interrupt is raised. Writing a 1 to BIOS\_RLS sets it to logic 1 and also sets GBL\_STS to logic 1; Writing a 0 to BIOS\_RLS has no effect. Writing a 1 to GBL\_STS clears it to logic 0 and also clears BIOS\_RLS to logic 0; writing a 0 to GBL\_STS has no effect.

For the ACPI software to raise an event to the BIOS software, GBL\_RLS, BIOS\_EN, and BIOS\_STS bits are involved. BIOS\_EN is the enable bit and the BIOS\_STS is the status bit. Both are controlled by the BIOS software. If GBL\_RLS is set by the ACPI software and BIOS\_EN is set by the BIOS software, an SMI is raised. Writing a 1 to GBL\_RLS sets it to logic 1 and also sets BIOS\_STS to logic 1; Writing a 0 to GBL\_RLS has no effect. Writing a 1 to BIOS\_STS clears it to logic 0 and also clears GBL\_RLS to logic 0; writing a 0 to BIOS\_STS has no effect.

For the bus master to raise an event to the ACPI software, BM\_CNTRL, BM\_RLD, and BM\_STS bits are involved. Both BM\_RLD and BM\_STS are controlled by the ACPI software. If BM\_CNTRL is set

by the BIOS software and BM\_RLD is set by the ACPI software, an SCI interrupt is raised. Writing a 1 to BM\_CNTRL sets it to logic 1 and also sets BM\_STS to logic 1; Writing a 0 to BM\_CNTRL has no effect. Writing a 1 to BM\_STS clears it to logic 0 and also clears BM\_CNTRL to logic 0; writing a 0 to BM\_STS has no effect.

### 8.3.2 Power Management Timer

In the ACPI specification, a power management timer is required. The power management timer is a 24-bit fixed rate free running count-up timer that runs off a 3.579545MHz clock. The power management timer has the corresponding status bit (TMR\_STS) and enable bit (TMR\_EN). The TMR\_STS bit is set any time the last bit of the timer (bit 23) goes from 0 to 1 or from 1 to 0. If the TMR\_EN bit is set, the setting of the TMR\_STS bit will generate an SCI interrupt. Three registers are used to read the timer value; they are located in the PM1 register block. The power management timer has one enable bit (TMR\_ON) to turn it on or off. The TMR\_ON is located in GPE register block. If it is cleared to 0, the power management timer function will not work. There are no timer reset requirements, except that the timer should function after power-up. See the following figure for an illustration.

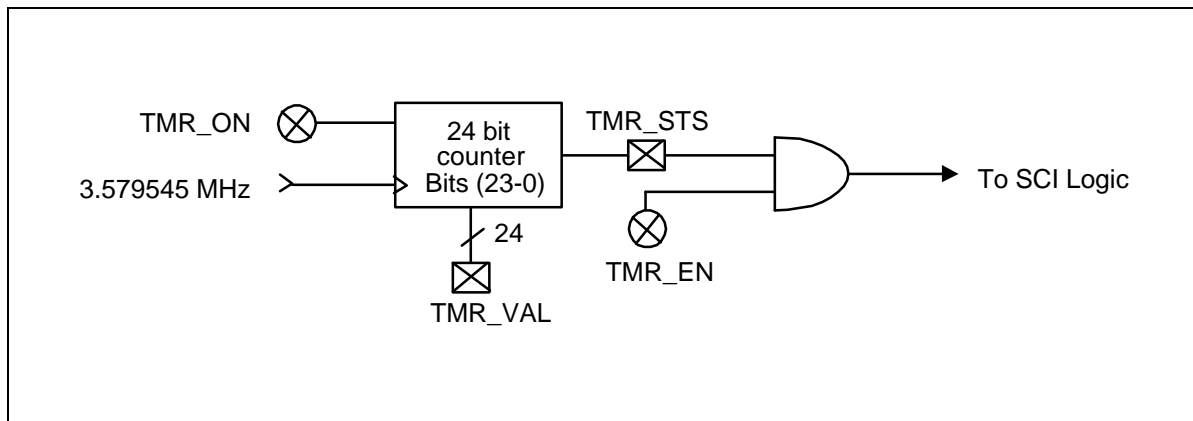

### 8.4 ACPI Registers (ACPIRs)

The ACPI register model consists of the fixed register blocks that perform the ACPI functions. A register block may be an event register block which deals with ACPI events, or a control register block which deals with control features. The ordering in the event register block is the status register, followed by the enable register.

Each event register, if implemented, contains two registers: a status register and an enable register, both in 16-bit size. The status register indicates what defined function needs the ACPI System Control Interrupt (SCI). When the hardware event occurs, the defined status bit is set. However, to generate the SCI, the associated enable bit must be set. If the enable bit is not set, the software can examine the state of the hardware event by reading the status bit without generating an SCI interrupt.

Any status bit, unless otherwise noted, can only be set by some defined hardware event. It is cleared by writing a 1 to its bit position; writing a 0 has no effect. Except for some special status bits, every status bit has an associated enable bit in the same bit position in the enable register. Those status bits which have no respective enable bit are read for special purposes. Reserved or un-implemented enable bits always return zero, and writing to these bits should have no effect.

The control bit in the control register provides some special control functions over the hardware event, or some special control over SCI event. Reserved or un-implemented control bits always return zero, and writing to those bits should have no effect.

Table 8-4 lists the PM1 register block and the relative locations of the registers within it. The base address of PM1 register block is named as PM1a\_EVT\_BLK in the ACPI specification. The base address should range from 01,0000,0000<sub>b</sub> to 11,1111,0000<sub>b</sub>, i.e., 100H ~ 3F0H, where bit 1 and bit 0 of PM1 register block should be set to 0 and the base address is in the 16-byte alignment.

Table 8-5 lists the GPE register block and the relative locations within it. The base address of power management event block GPE is named as GPE0\_BLK in the ACPI specification. The base address should range from 01,0000,0000<sub>b</sub> to 11,1111,1000<sub>b</sub>, i.e., 100H ~ 3F8H, where bit 0 of the base address should be set to 0 and the base address is in the 8-byte alignment.

**8.4.1 Power Management 1 Status Register 1 (PM1STS1)**

Register Location: <CR33> System I/O Space  
 Default Value: 00h  
 Attribute: Read/write  
 Size: 8 bits

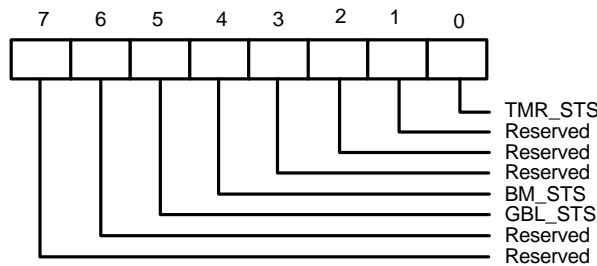

Bit	Name	Description
0	TMR_STS	This bit is the timer carry status bit. This bit gets set anytime the bit 23 of the 24-bit counter changes (whenever the MSB changes from low to high or high to low). While TMR_EN and TMR_STS are set, a power magement event is raised. This bit is only set by hardware and can only be cleared by the software writing a 1 to this bit position. Writing a 0 has no effect.
1-3	Reserved	Reserved.
4	BM_STS	This is the bus master status bit. Writing a 1 to BM_CNTRL also sets BM_STS. Writing a 1 clears this bit and also clears BM_CNTRL. Writing a 0 has no effect.
5	GBL_STS	This is the global status bit. This bit is set when the BIOS want the attention of the SCI handler. BIOS sets this bit by setting BIOS_RLS and can only be cleared by software writing a 1 to this bit position. Writing a 1 to this bit position also clears BIOS_RLS. Writing a 0 has no effect.
6-7	Reserved	Reserved. These bits always return a value of zero.

**8.4.2 Power Management 1 Status Register 2 (PM1STS2)**

Register Location: <CR33>+1H System I/O Space  
 Default Value: 00h  
 Attribute: Read/write  
 Size: 8 bits

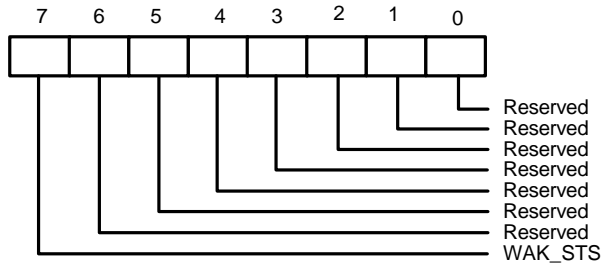

Bit	Name	Description
0-6	Reserved	Reserved.
7	WAK_STS	This bit is set when the system is in the sleeping state and an enabled resume event occurs. Upon setting this bit, the sleeping/working state machine will transition the system to the working state. This bit is only set by hardware, and is cleared by software writing a 1 to this bit position or by the sleeping/working state machine automatically upon the expiry of the global standby timer. Writing a 0 has no effect. Upon the WAK_STS being cleared and all devices being in sleeping state, the whole chip enters the sleeping state.

**8.4.3 Power Management 1 Enable Register 1 (PM1EN1)**

Register Location: <CR33>+2H System I/O Space  
 Default Value: 00h  
 Attribute: Read/write  
 Size: 8 bits

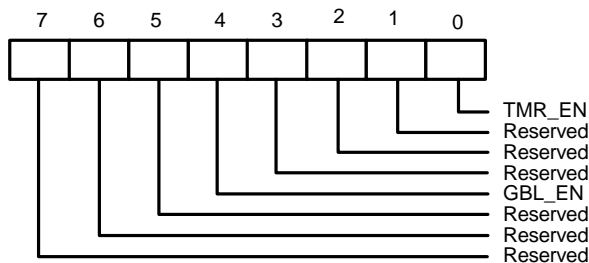

Bit	Name	Description
0	TMR_EN	This is the timer carry interrupt enable bit. When this bit is set, an SCI event is generated anytime the TMR_STS bit is set. When this bit is reset no interrupt is generated when the TMR_STS bit is set.
1-4	Reserved	Reserved. These bits always return a value of zero.
5	GBL_EN	The global enable bit. When both the GBL_EN bit and the GBL_STS bit are set, an SCI interrupt is raised.
6-7	Reserved	Reserved.

**8.4.4 Power Management 1 Enable Register 2 (PM1EN2)**

Register Location: <CR33>+3H System I/O Space  
 Default Value: 00h  
 Attribute: Read/write  
 Size: 8 bits

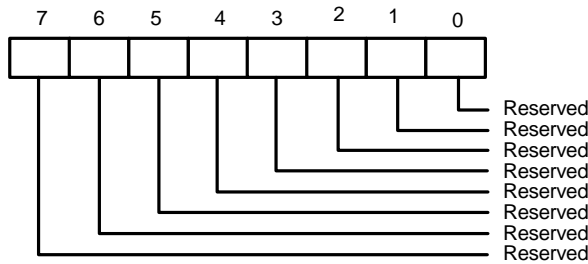

Bit	Name	Description
0-7	Reserved	Reserved. These bits always return a value of zero.

**8.4.5 Power Management 1 Control Register 1 (PM1CTL1)**

Register Location: <CR33>+4H System I/O Space  
 Default Value: 00h  
 Attribute: Read/write  
 Size: 8 bits

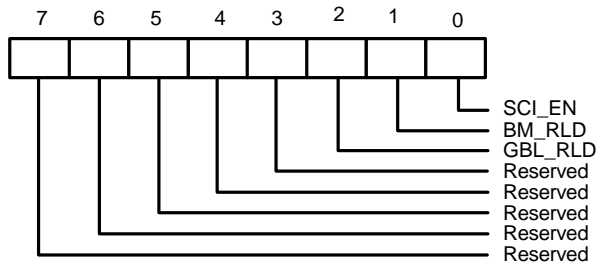

Bit	Name	Description
0	SCI_EN	Select the power management event to be either an SCI or an SMI interrupt. When this bit is set, the power management events will generate an SCI interrupt. When this bit is reset and SMI_EN bit is set, the power management events will generate an SMI interrupt.
1	BM_RLD	This is the bus master reload enable bit. If this bit is set and BM_CNTRL is set, an SCI interrupt is raised.
2	GBL_RLS	The global release bit. This bit is used by the ACPI software to raise an event to the BIOS software. The BIOS software has a corresponding enable and status bit to control its ability to receive the ACPI event. Setting GBL_RLS sets BIOS_STS, and it generates an SMI interrupt if BIOS_EN is also set.
3-7	Reserved	Reserved. These bits always return a value of zero.

**8.4.6 Power Management 1 Control Register 2 (PM1CTL2)**

Register Location: <CR33>+5H System I/O Space

Default Value: 00h

Attribute: Read/write

Size: 8 bits

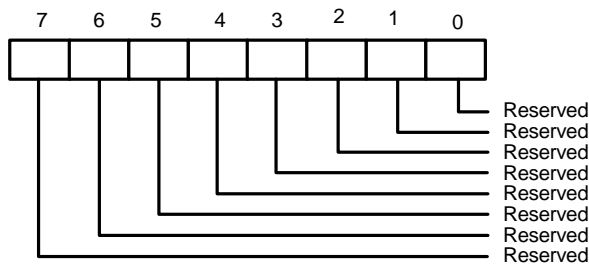

Bit	Name	Description
0-7	Reserved	Reserved. These bits always return a value of zero.

**8.4.7 Power Management 1 Control Register 3 (PM1CTL3)**

Register Location: <CR33>+6H System I/O Space  
 Default Value: 00h  
 Attribute: Read/write  
 Size: 8 bits

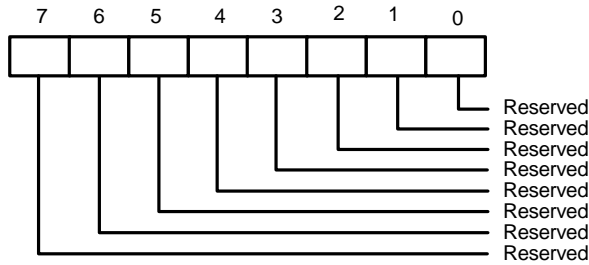

Bit	Name	Description
0-7	Reserved	Reserved. These bits always return a value of zero.

**8.4.8 Power Management 1 Control Register 4 (PM1CTL4)**

Register Location: <CR33>+7H System I/O Space  
 Default Value: 00h  
 Attribute: Read/write  
 Size: 8 bits

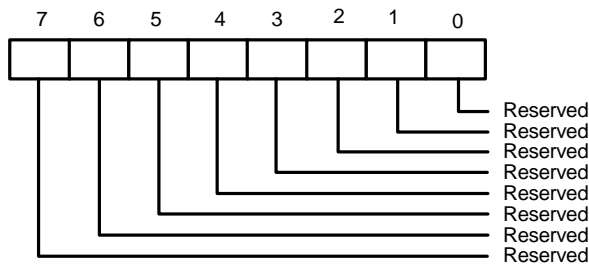

Bit	Name	Description
0-7	Reserved	Reserved. These bits always return a value of zero.

**8.4.9 Power Management 1 Timer 1 (PM1TMR1)**

Register Location: <CR33>+8H System I/O Space  
 Default Value: 00h  
 Attribute: Read only  
 Size: 8 bits

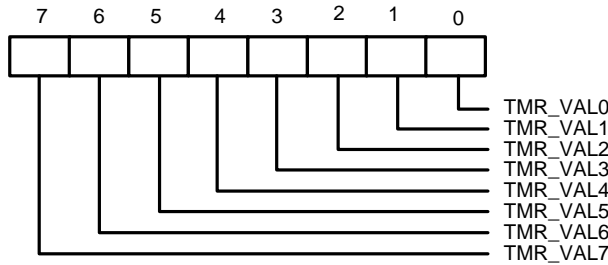

Bit	Name	Description
0-7	TMR_VAL	This read-only field returns the running count of the power management timer. This is a 24-bit counter that runs off of a 3.579545 MHz clock, and counts while in the system working state. The timer is reset and then continues counting until the CLKIN input to the chip is stopped. If the clock is restarted without a MR reset, then the counter will continue counting from where it stopped. The TMR_STS bit is set any time the last bit of the timer (bit 23) goes from 0 to 1 or from 1 to 0. If the TMR_EN bit is set, the setting of the TMR_STS bit will generate an SCI interrupt.

**8.4.10 Power Management 1 Timer 2 (PM1TMR2)**

Register Location: <CR33>+9H System I/O Space  
 Default Value: 00h  
 Attribute: Read only  
 Size: 8 bits

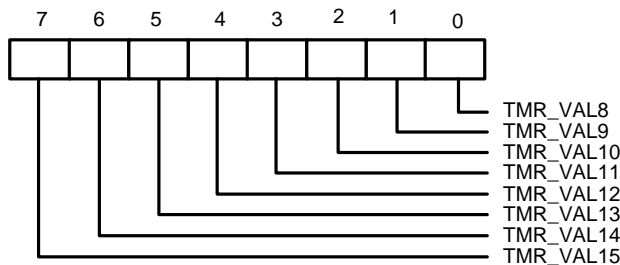

Bit	Name	Description
0-7	TMR_VAL	This read-only field returns the running count of the power management timer. This is a 24-bit counter that runs off of a 3.579545 MHz clock, and counts while in the system working state. The timer is reset and then continues counting until the CLKIN input to the chip is stopped. If the clock is restarted without a MR reset, then the counter will continue counting from where it stopped. The TMR_STS bit is set any time the last bit of the timer (bit 23) goes from 0 to 1 or from 1 to 0. If the TMR_EN bit is set, the setting of the TMR_STS bit will generate an SCI interrupt.

**8.4.11 Power Management 1 Timer 3 (PM1TMR3)**

Register Location: <CR33>+AH System I/O Space  
 Default Value: 00h  
 Attribute: Read only  
 Size: 8 bits

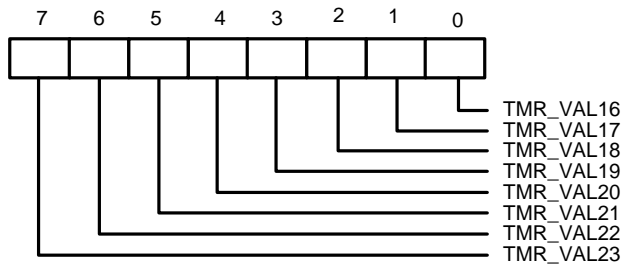

Bit	Name	Description
0-7	TMR_VAL	This read-only field returns the running count of the power management timer. This is a 24-bit counter that runs off of a 3.579545 MHz clock, and counts while in the system working state. The timer is reset and then continues counting until the CLKIN input to the chip is stopped. If the clock is restarted without a MR reset, then the counter will continue counting from where it stopped. The TMR_STS bit is set any time the last bit of the timer (bit 23) goes from 0 to 1 or from 1 to 0. If the TMR_EN bit is set, the setting of the TMR_STS bit will generate an SCI interrupt.

**8.4.12 Power Management 1 Timer 4 (PM1TMR4)**

Register Location: <CR33>+BH System I/O Space  
 Default Value: 00h  
 Attribute: Read only  
 Size: 8 bits

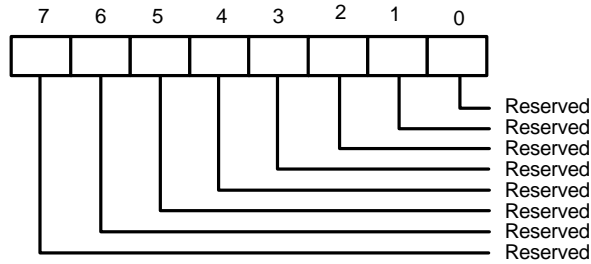

Bit	Name	Description
0-7	Reserved	Reserved. These bits always return a value of zero.

**8.4.13 General Purpose Event 0 Status Register 1 (GP0STS1)**

Register Location: <CR34> System I/O Space  
 Default Value: 00h  
 Attribute: Read/write  
 Size: 8 bits

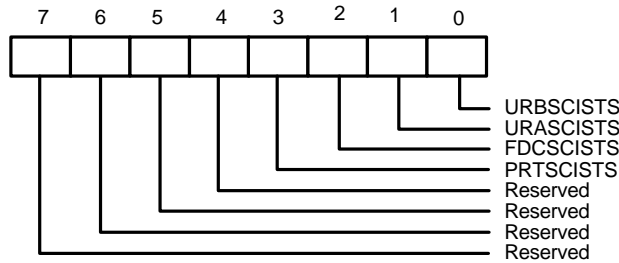

These bits indicate the status of the SCI input, which is set when the device's IRQ is raised. If the corresponding enable bit in the SCI interrupt enable register (in GP0EN1) is set, an SCI interrupt is raised and routed to the output pin. Writing a 1 clears the bit, and writing a 0 has no effect. If the bit is not cleared, new IRQ for the SCI logic input is ignored, therefore no SCI interrupt is raised.

Bit	Name	Description
0	URBSCISTS	UART B SCI status, which is set by the UART B IRQ.
1	URASCISTS	UART A SCI status, which is set by the UART A IRQ.
2	FDCSCISTS	FDC SCI status, which is set by the FDC IRQ.
3	PRTSCISTS	PRT SCI status, which is set by the printer port IRQ.
4-7	Reserved	Reserved.

**8.4.14 General Purpose Event 0 Status Register 2 (GP0STS2)**

Register Location: <CR34>+1H System I/O Space  
 Default Value: 00h  
 Attribute: Read/write  
 Size: 8 bits

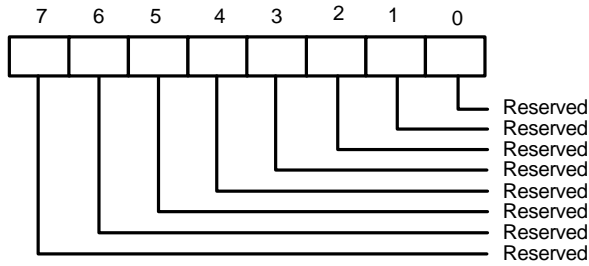

Bit	Name	Description
0-7	Reserved	Reserved. These bits always return a value of zero.

**8.4.15 General Purpose Event 0 Enable Register 1 (GP0EN1)**

Register Location: <CR34> +2H System I/O Space  
 Default Value: 00h  
 Attribute: Read/write  
 Size: 8 bits

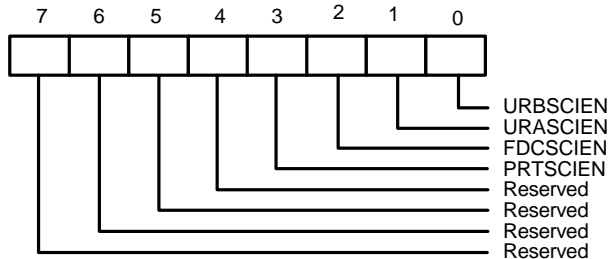

These bits are used to enable the device's IRQ sources onto the SCI logic. The SCI logic output for the IRQs is as follows:

SCI logic output = (URBSCIEN and URBSCISTS) or (URASCIEN and URASCISTS) or (FDCSCIEN and FDCSCISTS) or (PRTSCIEN and PRTSCISTS)

Bit	Name	Description
0	URBSCIEN	UART B SCI enable, which controls the UART B IRQ for SCI.
1	URASCIEN	UART A SCI enable, which controls the UART A IRQ for SCI.
2	FDCSCIEN	FDC SCI enable, which controls the FDC IRQ for SCI.
3	PRTSCIEN	Printer port SCI enable, which controls the printer port IRQ for SCI.
4-7	Reserved	Reserved.

**8.4.16 General Purpose Event 0 Enable Register 2 (GP0EN2)**

Register Location: <CR34>+3H System I/O Space

Default Value: 00h

Attribute: Read/write

Size: 8 bits

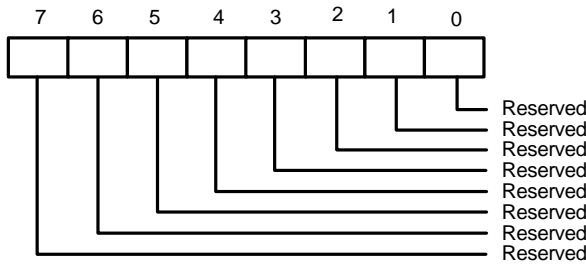

Bit	Name	Description
0-7	Reserved	Reserved. These bits always return a value of zero.

**8.4.17 General Purpose Event 1 Status Register 1 (GP1STS1)**

Register Location: <CR34>+4H System I/O Space

Default Value: 00h

Attribute: Read/write

Size: 8 bits

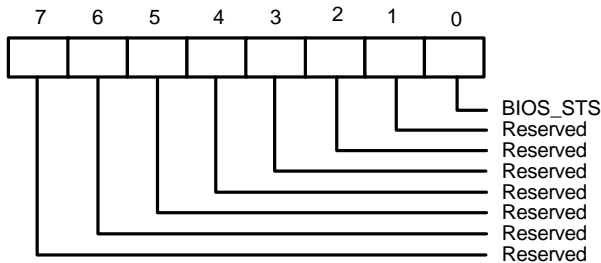

Bit	Name	Description
0	BIOS_STS	The BIOS status bit. This bit is set when GBL_RLS is set. If BIOS_EN is set, setting GBL_RLS will raise an SMI event. Writing a 1 to its bit location clears BIOS_STS and also clears GBL_RLS. Writing a 0 has no effect.
1-7	Reserved	Reserved.

**8.4.18 General Purpose Event 1 Status Register 2 (GP1STS2)**

Register Location: <CR34>+5H System I/O Space  
 Default Value: 00h  
 Attribute: Read/write  
 Size: 8 bits

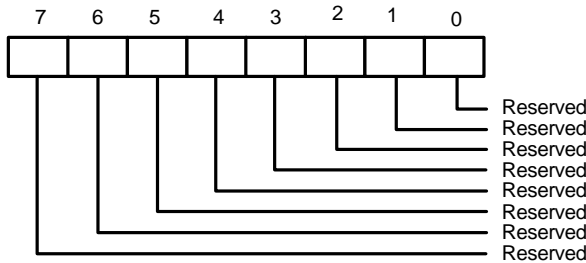

Bit	Name	Description
0-7	Reserved	Reserved. These bits always return a value of zero.

**8.4.19 General Purpose Event 1 Enable Register 1 (GP1EN1)**

Register Location: <CR34>+6H System I/O Space  
 Default Value: 00h  
 Attribute: Read/write  
 Size: 8 bits

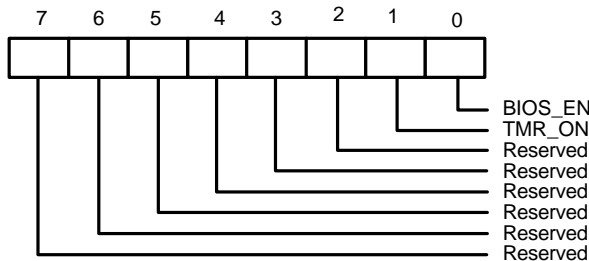

Bit	Name	Description
0	BIOS_EN	This bit raise the SMI event. When this bit is set and the ACPI software writes a 1 to the GBL_RLS bit, an SMI event is raised on the SMI logic output.
1	TMR_ON	This bit is used to turn on the power management timer. 1: timer on ; 0: timer off.
2-7	Reserved	Reserved.

**8.4.20 General Purpose Event 1 Enable Register 2 (GP1EN2)**

Register Location: <CR34>+7H System I/O Space  
 Default Value: 00h  
 Attribute: Read/write  
 Size: 8 bits

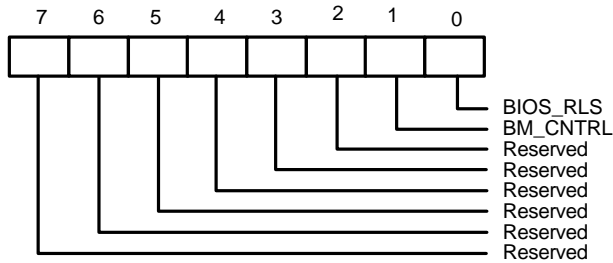

Bit	Name	Description
0	BIOS_RLS	The BIOS release bit. This bit is used by the BIOS software to raise an event to the ACPI software. The ACPI software has a corresponding enable and status bit to control its ability to receive the ACPI event. Setting BIOS_RLS sets GBL_STS, and it generates an SCI interrupt if GBL_EN is also set. Writing a 1 to its bit position sets this bit and also sets the BM_STS bit. Writing a 0 has no effect. This bit is cleared by writing a 1 to the GBL_STS bit.
1	BM_CNTRL	This bit is used to set the BM_STS bit and if the BM_RLD bit is also set, then an SCI interrupt is generated. Writing a 1 sets BM_CNTRL to 1 and also sets BM_STS. Writing a 0 has no effect. Writing a 1 to BM_STS clears BM_STS and also clears BM_CNTRL.
2-7	Reserved	Reserved.

**8.4.21 Bit Map Configuration Registers**
**Table 8-4: Bit Map of PM1 Register Block**

Register	Address	Power-On Reset Value	D7	D6	D5	D4	D3	D2	D1	D0
PM1STS1	<CR33>	0000 0000	0	0	GBL_STS	BM_STS	0	0	0	TMR_STS
PM1STS2	<CR33>+1H	0000 0000	WAK_STS	0	0	0	0	0	0	0
PM1EN1	<CR33>+2H	0000 0000	0	0	GBL_EN	0	0	0	0	TMR_EN
PM1EN2	<CR33>+3H	0000 0000	0	0	0	0	0	0	0	0
PM1CTL1	<CR33>+4H	0000 0000	0	0	0	0	0	GBL_RLS	BM_RLD	SCI_EN
PM1CTL2	<CR33>+5H	0000 0000	0	0	0	0	0	0	0	0
PM1CTL3	<CR33>+6H	0000 0000	0	0	0	0	0	0	0	0
PM1CTL4	<CR33>+7H	0000 0000	0	0	0	0	0	0	0	0
PM1TMR1	<CR33>+8H	0000 0000	TMR_VAL7	TMR_VAL6	TMR_VAL5	TMR_VAL4	TMR_VAL3	TMR_VAL2	TMR_VAL1	TMR_VAL0
PM1TMR2	<CR33>+9H	0000 0000	TMR_VAL15	TMR_VAL14	TMR_VAL13	TMR_VAL12	TMR_VAL11	TMR_VAL10	TMR_VAL9	TMR_VAL8
PM1TMR3	<CR33>+AH	0000 0000	TMR_VAL23	TMR_VAL22	TMR_VAL21	TMR_VAL20	TMR_VAL19	TMR_VAL18	TMR_VAL17	TMR_VAL16
PM1TMR4	<CR33>+BH	0000 0000	0	0	0	0	0		0	0

**Table 8-5: Bit Map of GPE Register Block**

Register	Address	Power-On Reset Value	D7	D6	D5	D4	D3	D2	D1	D0
GP0STS1	<CR34>	0000 0000	0	0	0	0	PRTSCISTS	FDCSCISTS	URASCISTS	URBSCISTS
GP0STS2	<CR34>+1H	0000 0000	0	0	0	0	0	0	0	0
GP0EN1	<CR34>+2H	0000 0000	0	0	0	0	PRTSCIEN	FDCSCIEN	URASCIEN	URBSCIEN
GP0EN2	<CR34>+3H	0000 0000	0	0	0	0	0	0	0	0
GP1STS1	<CR34>+4H	0000 0000	0	0	0	0	0	0	0	BIOS_STS
GP1STS2	<CR34>+5H	0000 0000	0	0	0	0	0	0	0	0
GP1EN1	<CR34>+6H	0000 0000	0	0	0	0	0	0	TMR_ON	BIOS_EN
GP1EN2	<CR34>+7H	0000 0000	0	0	0	0	0	0	BM_CNTRL	BIOS_RLS

## 9.0 SPECIFICATIONS

### 9.1 Absolute Maximum Ratings

PARAMETER	RATING	UNIT
Power Supply Voltage	-0.5 to 7.0	V
Input Voltage	-0.5 to VDD+0.5	V
Operating Temperature	0 to +70	°C
Storage Temperature	-55 to +150	°C

Note: Exposure to conditions beyond those listed under Absolute Maximum Ratings may adversely affect the life and reliability of the device.

### 9.2 DC CHARACTERISTICS

(Ta = 0° C to 70° C, VDD = 5V ± 10%, VSS = 0V)

PARAMETER	SYM.	MIN.	TYP.	MAX.	UNI	CONDITIONS
<b>I/O<sub>8t</sub> - TTL level output pin with source-sink capabilities of 8 mA; CMOS level input voltage</b>						
Input Low Voltage	VIL	-0.5		0.3xVDD	V	
Input High Voltage	VIH	0.7xVDD		VDD+0.5	V	
Output Low Voltage	VOL			0.4	V	IOL = 8 mA
Output High Voltage	VOH	2.4			V	IOH = -8 mA
Input High Leakage	ILIH			+10	μA	VIN = VDD
Input Low Leakage	ILIL			-10	μA	VIN = 0V
<b>I/O<sub>12t</sub> - TTL level bi-directional pin with source-sink capabilities of 12 mA</b>						
Input Low Voltage	VIL	-0.5		0.8	V	
Input High Voltage	VIH	2.0		VDD+0.5	V	
Output Low Voltage	VOL			0.4	V	IOL = 12 mA
Output High Voltage	VOH	2.4			V	IOH = -12 mA
Input High Leakage	ILIH			+10	μA	VIN = VDD
Input Low Leakage	ILIL			-10	μA	VIN = 0V
<b>I/O<sub>24t</sub> - TTL level bi-directional pin with source-sink capabilities of 24 mA</b>						
Input Low Voltage	VIL	-0.5		0.8	V	
Input High Voltage	VIH	2.0		VDD+0.5	V	
Output Low Voltage	VOL			0.4	V	IOL = 24 mA
Output High Voltage	VOH	2.4			V	IOH = -24 mA
Input High Leakage	ILIH			+10	μA	VIN = VDD
Input Low Leakage	ILIL			-10	μA	VIN = 0V

**9.2 DC Characteristics, continued**

PARAMETER	SYM.	MIN.	TYP.	MAX.	UNIT	CONDITIONS
<b>OUT<sub>8t</sub> - TTL level output pin with source-sink capabilities of 8 mA</b>						
Output Low Voltage	VOL			0.4	V	IOL = 8 mA
Output High Voltage	VOH	2.4			V	IOH = -8 mA
<b>OUT<sub>12t</sub> - TTL level output pin with source-sink capabilities of 12 mA</b>						
Output Low Voltage	VOL			0.4	V	IOL = 12 mA
Output High Voltage	VOH	2.4			V	IOH = -12 mA
<b>OD<sub>12</sub> - Open-drain output pin with sink capabilities of 12 mA</b>						
Output Low Voltage	VOL			0.4	V	IOL = 12 mA
<b>OD<sub>24</sub> - Open-drain output pin with sink capabilities of 24 mA</b>						
Output Low Voltage	VOL			0.4	V	IOL = 24 mA
<b>IN<sub>t</sub> - TTL level input pin</b>						
Input Low Voltage	VIL			0.8	V	VDD = 5 V
Input High Voltage	VIH	2.0			V	VDD = 5 V
Input High Leakage	ILIH			+10	μA	VIN = VDD
Input Low Leakage	ILIL			-10	μA	VIN = 0V
<b>IN<sub>ts</sub> - TTL level input pin Schmitt-trigger input pin</b>						
Input Low Threshold Voltage	Vt-	0.5	0.8	1.1	V	VDD = 5 V
Input High Threshold Voltage	Vt+	1.6	2.0	2.4	V	VDD = 5 V
Hysteresis (Vt+ - Vt-)	VTH	0.5	1.2		V	VDD = 5 V
Input High Leakage	ILIH			+10	μA	VIN = VDD
Input Low Leakage	ILIL			-10	μA	VIN = 0V
<b>IN<sub>c</sub> - CMOS level input pin</b>						
Input Low Voltage	VIL			0.3xVDD	V	VDD = 5 V
Input High Voltage	VIH	0.7xVDD			V	VDD = 5 V
Input High Leakage	ILIH			+10	μA	VIN = VDD
Input Low Leakage	ILIL			-10	μA	VIN = 0V
<b>IN<sub>cs</sub> - CMOS level schmitt-triggered input pin</b>						
Input Low Threshold Voltage	Vt-	1.3	1.5	1.7	V	VDD = 5 V
Input High Threshold Voltage	Vt+	3.2	3.5	3.8	V	VDD = 5 V
Hysteresis (Vt+ - Vt-)	VTH	1.5	2		V	VDD = 5 V
Input High Leakage	ILIH			+10	μA	VIN = VDD
Input Low Leakage	ILIL			-10	μA	VIN = 0V

### 9.3 AC Characteristics

FDC: Data rate = 1 MB/500 KB/300 KB/250 KB/sec.

PARAMETER	SYM.	TEST CONDITIONS	MIN.	TYP. (NOTE 1)	MAX.	UNIT
SA9-SA0, AEN, $\overline{\text{DACK}}$ , $\overline{\text{CS}}$ , setup time to $\overline{\text{IOR}}_{i\delta}$	TAR		25			nS
SA9-SA0, AEN, $\overline{\text{DACK}}$ , hold time for $\overline{\text{IOR}}_{i\delta}$	TAR		0			nS
$\overline{\text{IOR}}$ width	TRR		80			nS
Data access time from $\overline{\text{IOR}}_{i\delta}$	TFD	CL = 100 pf			80	nS
Data hold from $\overline{\text{IOR}}_{i\delta}$	TDH	CL = 100 pf	10			nS
SD to from $\overline{\text{IOR}}_{i\delta}$	TDF	CL = 100 pf	10		50	nS
IRQ delay from $\overline{\text{IOR}}_{i\delta}$	TRI				360/570 /675	nS
SA9-SA0, AEN, $\overline{\text{DACK}}$ , setup time to $\overline{\text{IOW}}_{i\delta}$	TAW		25			nS
SA9-SA0, AEN, $\overline{\text{DACK}}$ , hold time for $\overline{\text{IOW}}_{i\delta}$	TWA		0			nS
$\overline{\text{IOW}}$ width	TWW		60			nS
Data setup time to $\overline{\text{IOW}}_{i\delta}$	TDW		60			nS
Data hold time from $\overline{\text{IOW}}_{i\delta}$	TWD		0			nS
IRQ delay from $\overline{\text{IOW}}_{i\delta}$	TWI				360/570 /675	nS
DRQ cycle time	TMCY		27			$\mu\text{S}$
DRQ delay time $\overline{\text{DACK}}_{i\delta}$	TAM				50	nS
DRQ to $\overline{\text{DACK}}$ delay	TMA		0			nS
$\overline{\text{DACK}}$ width	TAA		260/430 /510			nS
$\overline{\text{IOR}}$ delay from $\overline{\text{DRQ}}$	TMR		0			nS
$\overline{\text{IOW}}$ delay from $\overline{\text{DRQ}}$	TMW		0			nS

**9.3.1 AC Characteristics, FDC continued**

PARAMETER	SYM.	TEST CONDITIONS	MIN.	TYP. (NOTE 1)	MAX.	UNIT
$\overline{\text{IOW}}$ or $\overline{\text{IOR}}$ response time from DRQ	TMRW			6/12 /20/24		$\mu\text{S}$
TC width	TTC		135/220 /260			nS
RESET width	TRST		1.8/3/3. 5			$\mu\text{S}$
$\overline{\text{INDEX}}$ width	TIDX		0.5/0.9 /1.0			$\mu\text{S}$
$\overline{\text{DIR}}$ setup time to $\overline{\text{STEP}}$	TDST		1.0/1.6 /2.0			$\mu\text{S}$
$\overline{\text{DIR}}$ hold time from $\overline{\text{STEP}}$	TSTD		24/40/48			$\mu\text{S}$
$\overline{\text{STEP}}$ pulse width	TSTP		6.8/11.5 /13.8	7/11.7 /14	7.2/11.9 /14.2	$\mu\text{S}$
$\overline{\text{STEP}}$ cycle width	TSC		Note 2	Note 2	Note 2	$\mu\text{S}$
$\overline{\text{WD}}$ pulse width	TWDD		100/185 /225	125/210 /250	150/235 /275	$\mu\text{S}$
Write precompensation	TWPC		100/138 /225	125/210 /250	150/235 /275	$\mu\text{S}$

Notes:

1. Typical values for T = 25° C and normal supply voltage.
2. Programmable from 2 mS through 32 mS in 2 mS increments.

**UART/Parallel Port**

PARAMETER	SYMBOL	TEST CONDITIONS	MIN.	MAX.	UNIT
Delay from Stop to Set Interrupt	TSINT		9/16		Baud Rate
Delay from $\overline{\text{IOR}}$ Reset Interrupt	TRINT	100 pF Loading		1	$\mu\text{S}$
Delay from Initial IRQ Reset to Transmit Start	TIRS		1/16	8/16	Baud Rate
Delay from $\overline{\text{IOW}}$ to Reset Interrupt	THR	100 pF Loading		175	nS
Delay from Initial $\overline{\text{IOW}}$ to Interrupt	TSI		9/16	16/16	Baud Rate
Delay from Stop to Set Interrupt	TSTI			1/2	Baud Rate
Delay from $\overline{\text{IOR}}$ to Reset Interrupt	TIR	100 pF Loading		250	nS
Delay from $\overline{\text{IOR}}$ to Output	TMWO	100 pF Loading		200	nS
Set Interrupt Delay from Modem Input	TSIM			250	nS
Reset Interrupt Delay from $\overline{\text{IOR}}$	TRIM			250	nS
Interrupt Active Delay	TIAD	100 pF Loading		25	nS
Interrupt Inactive Delay	TIID	100 pF Loading		30	nS
Baud Divisor	N	100 pF Loading		$2^{16}-1$	

**Parallel Port Mode Parameters**

PARAMETER	SYM.	MIN.	TYP.	MAX.	UNIT
PD0-7, $\overline{\text{INDEX}}$ , $\overline{\text{STROBE}}$ , $\overline{\text{AUTOFD}}$ Delay from $\overline{\text{IOW}}$	t1			100	nS
IRQ Delay from $\overline{\text{ACK}}$ , nFAULT	t2			60	nS
IRQ Delay from $\overline{\text{IOW}}$	t3			105	nS
IRQ Active Low in ECP and EPP Modes	t4	200		300	nS
$\overline{\text{ERROR}}$ Active to IRQ Active	t5			105	nS

**EPP Data or Address Read Cycle Timing Parameters**

PARAMETER	SYM.	MIN.	MAX.	UNIT
Ax Valid to $\overline{\text{IOR}}$ Asserted	t1	40		nS
IOCHRDY Deasserted to $\overline{\text{IOR}}$ Deasserted	t2	0		nS
$\overline{\text{IOR}}$ Deasserted to Ax Valid	t3	10	10	nS
$\overline{\text{IOR}}$ Deasserted to $\overline{\text{IOW}}$ or $\overline{\text{IOR}}$ Asserted	t4	40		
$\overline{\text{IOR}}$ Asserted to IOCHRDY Asserted	t5	0	24	nS
PD Valid to SD Valid	t6	0	75	nS
$\overline{\text{IOR}}$ Deasserted to SD Hi-Z (Hold Time)	t7	0	40	$\mu\text{S}$
SD Valid to IOCHRDY Deasserted	t8	0	85	nS
$\overline{\text{WAIT}}$ Deasserted to IOCHRDY Deasserted	t9	60	160	nS
PD Hi-Z to PDBIR Set	t10	0		nS
$\overline{\text{WRITE}}$ Deasserted to $\overline{\text{IOR}}$ Asserted	t13	0		nS
$\overline{\text{WAIT}}$ Asserted to $\overline{\text{WRITE}}$ Deasserted	t14	0	185	nS
Deasserted to $\overline{\text{WRITE}}$ Modified	t15	60	190	nS
$\overline{\text{IOR}}$ Asserted to PD Hi-Z	t16	0	50	nS
$\overline{\text{WAIT}}$ Asserted to PD Hi-Z	t17	60	180	nS
Command Asserted to PD Valid	t18	0		nS
Command Deasserted to PD Hi-Z	t19	0		nS
$\overline{\text{WAIT}}$ Deasserted to PD Drive	t20	60	190	nS
$\overline{\text{WRITE}}$ Deasserted to Command	t21	1		nS
PBDIR Set to Command	t22	0	20	nS
PD Hi-Z to Command Asserted	t23	0	30	nS
Asserted to Command Asserted	t24	0	195	nS
$\overline{\text{WAIT}}$ Deasserted to Command Deasserted	t25	60	180	nS
Time out	t26	10	12	nS
PD Valid to $\overline{\text{WAIT}}$ Deasserted	t27	0		nS
PD Hi-Z to $\overline{\text{WAIT}}$ Deasserted	t28	0		$\mu\text{S}$

**EPP Data or Address Write Cycle Timing Parameters**

PARAMETER	SYM.	MIN.	MAX.	UNIT
Ax Valid to $\overline{IOW}$ Asserted	t1	40		nS
SD Valid to Asserted	t2	10		nS
$\overline{IOW}$ Deasserted to Ax Invalid	t3	10		nS
$\overline{WAIT}$ Deasserted to IOCHRDY Deasserted	t4	0		nS
Command Asserted to $\overline{WAIT}$ Deasserted	t5	10		nS
$\overline{IOW}$ Deasserted to $\overline{IOW}$ or $\overline{IOR}$ Asserted	t6	40		nS
IOCHRDY Deasserted to $\overline{IOW}$ Deasserted	t7	0	24	nS
$\overline{WAIT}$ Asserted to Command Asserted	t8	60	160	nS
$\overline{IOW}$ Asserted to $\overline{WAIT}$ Asserted	t9	0	70	nS
PBDIR Low to $\overline{WRITE}$ Asserted	t10	0		nS
$\overline{WAIT}$ Asserted to $\overline{WRITE}$ Asserted	t11	60	185	nS
$\overline{WAIT}$ Asserted to $\overline{WRITE}$ Change	t12	60	185	nS
$\overline{IOW}$ Asserted to PD Valid	t13	0	50	nS
$\overline{WAIT}$ Asserted to PD Invalid	t14	0		nS
PD Invalid to Command Asserted	t15	10		nS
$\overline{IOW}$ to Command Asserted	t16	5	35	nS
$\overline{WAIT}$ Asserted to Command Asserted	t17	60	210	nS
$\overline{WAIT}$ Deasserted to Command Deasserted	t18	60	190	nS
Command Asserted to $\overline{WAIT}$ Deasserted	t19	0	10	$\mu$ S
Time out	t20	10	12	$\mu$ S
Command Deasserted to $\overline{WAIT}$ Asserted	t21	0		nS
$\overline{IOW}$ Deasserted to $\overline{WRITE}$ Deasserted and PD invalid	t22	0		nS

**Parallel Port FIFO Timing Parameters**

PARAMETER	SYMBOL	MIN.	MAX.	UNIT
DATA Valid to nSTROBE Active	t1	600		nS
nSTROBE Active Pulse Width	t2	600		nS
DATA Hold from nSTROBE Inactive	t3	450		nS
BUSY Inactive to PD Inactive	t4	80		nS
BUSY Inactive to nSTROBE Active	t5	680		nS
nSTROBE Active to BUSY Active	t6		500	nS

**ECP Parallel Port Forward Timing Parameters**

PARAMETER	SYMBOL	MIN.	MAX.	UNIT
nAUTOFD Valid to nSTROBE Asserted	t1	0	60	nS
PD Valid to nSTROBE Asserted	t2	0	60	nS
BUSY Deasserted to nAUTOFD Changed	t3	80	180	nS
BUSY Deasserted to PD Changed	t4	80	180	nS
nSTROBE Deasserted to BUSY Deasserted	t5	0		nS
BUSY Deasserted to nSTROBE Asserted	t6	80	200	nS
nSTROBE Asserted to BUSY Asserted	t7	0		nS
BUSY Asserted to nSTROBE Deasserted	t8	80	180	nS

**ECP Parallel Port Reverse Timing Parameters**

PARAMETER	SYMBOL	MIN.	MAX.	UNIT
PD Valid to nACK Asserted	t1	0		nS
nAUTOFD Deasserted to PD Changed	t2	0		nS
nAUTOFD Asserted to nACK Asserted	t3	0		nS
nAUTOFD Deasserted to nACK Deasserted	t4	0		nS
nACK Deasserted to nAUTOFD Asserted	t5	80	200	nS
PD Changed to nAUTOFD Deasserted	t6	80	200	nS

## 10.0 TIMING WAVEFORMS

### 10.1 FDC

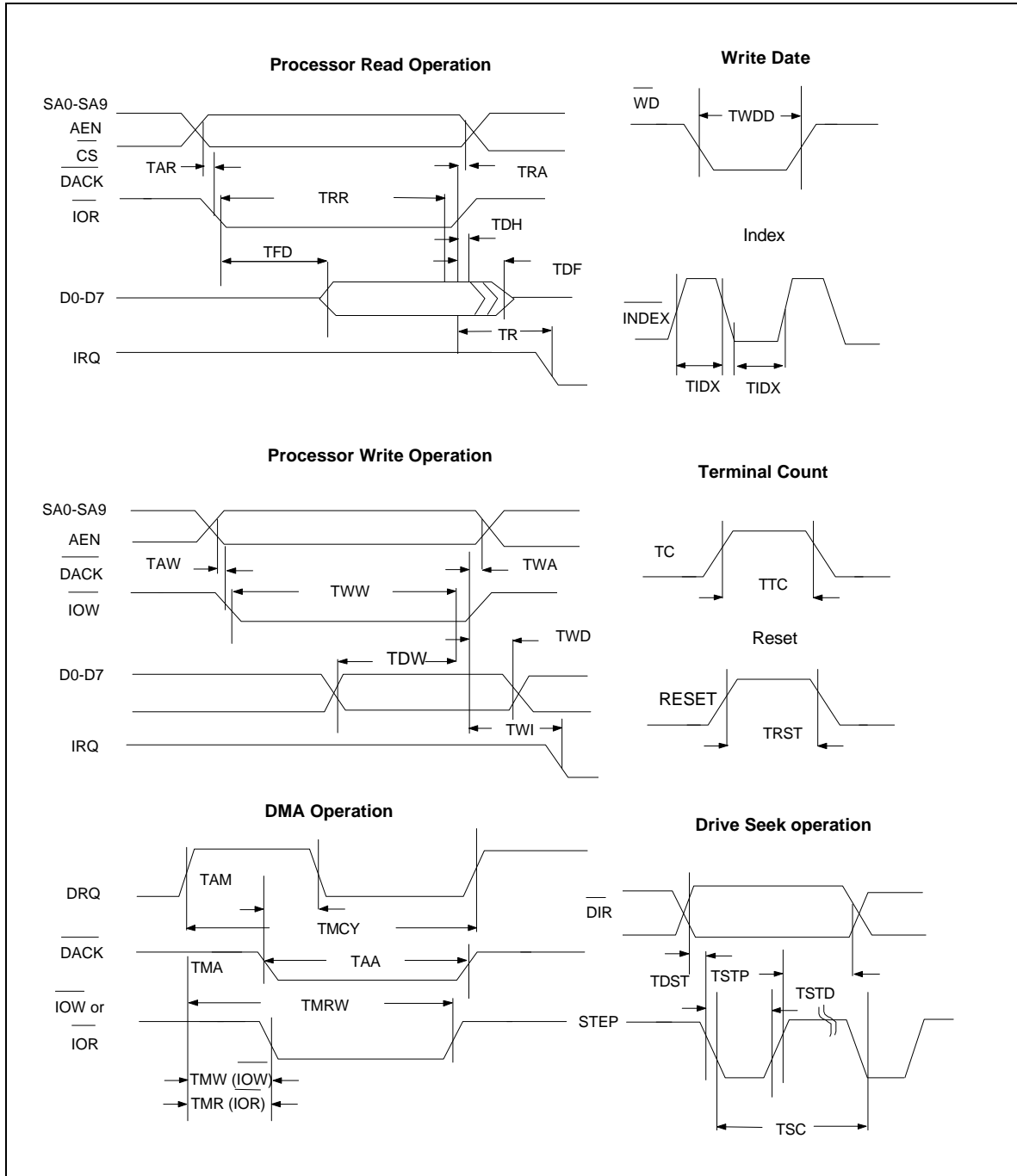

**10.2 UART/Parallel**

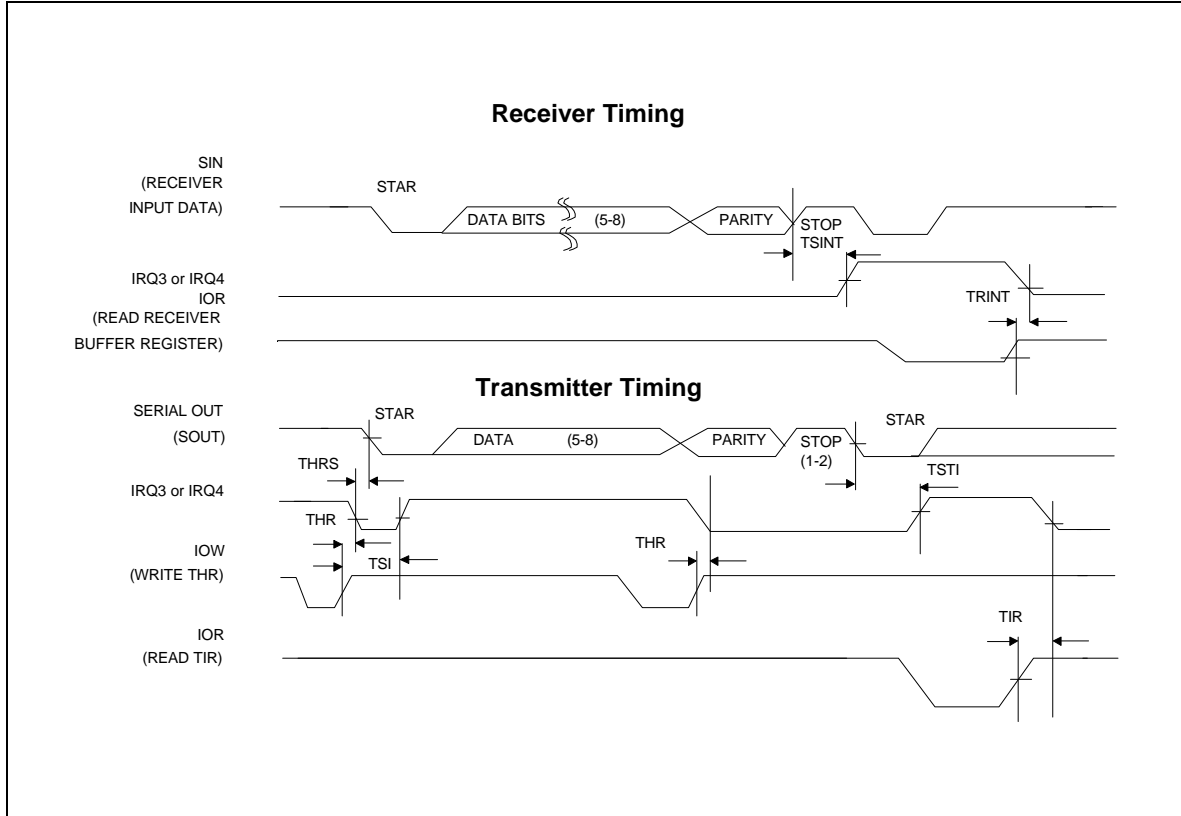

**Modem Control Timing**

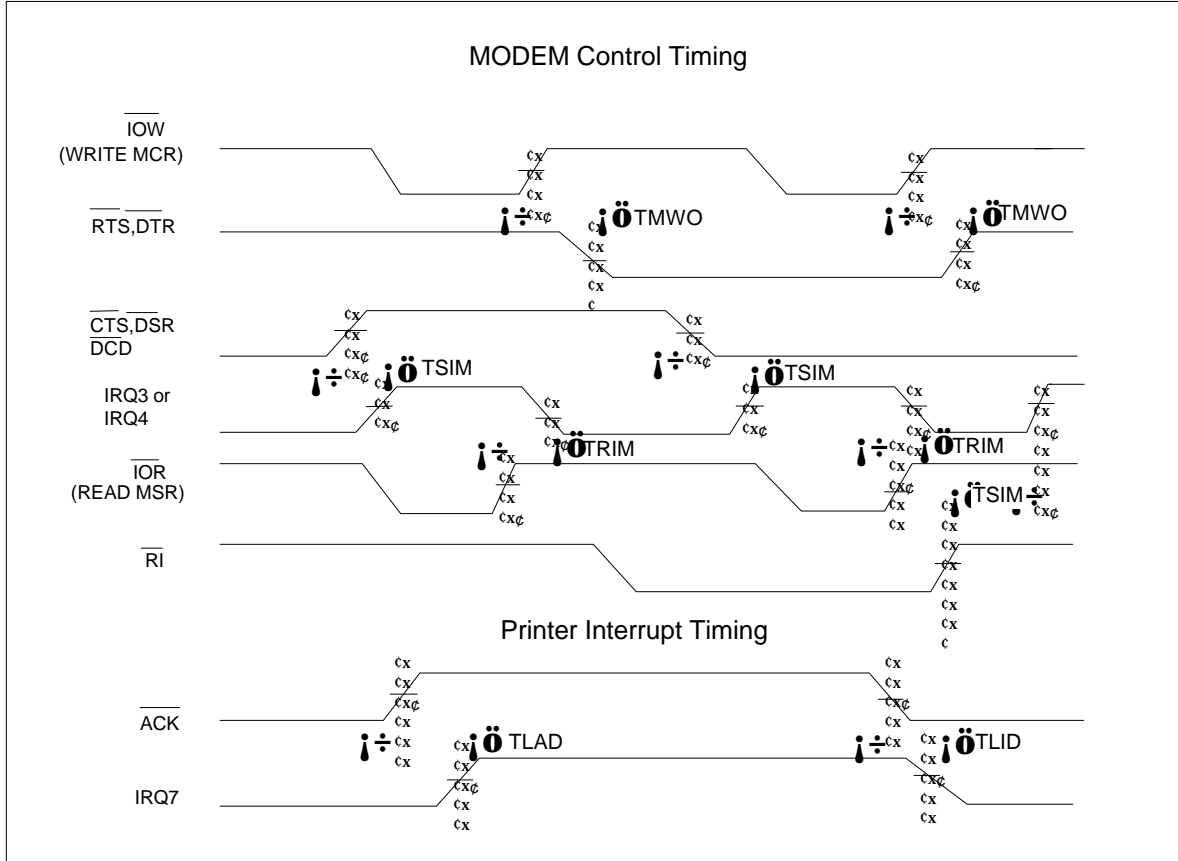

### 10.3 Parallel Port

#### Parallel Port Timing

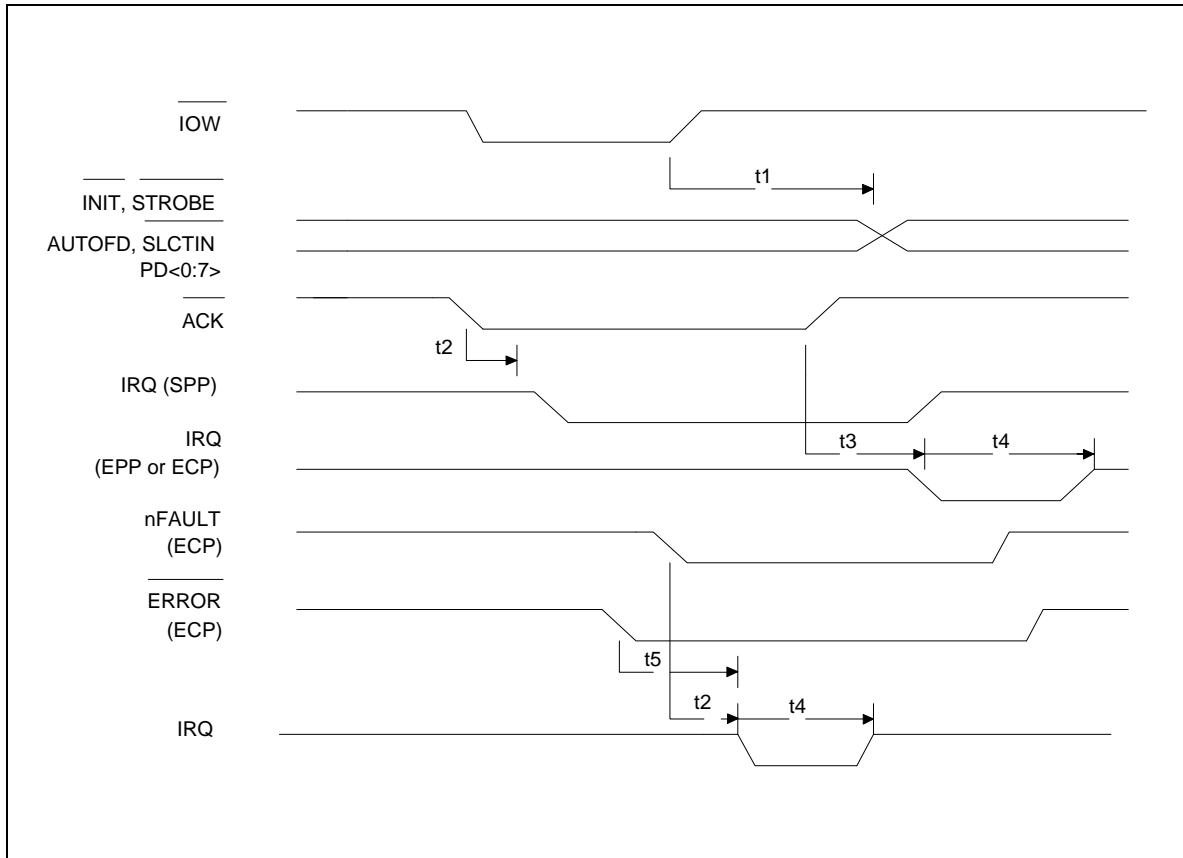

EPP Data or Address Read Cycle (EPP Version 1.9)

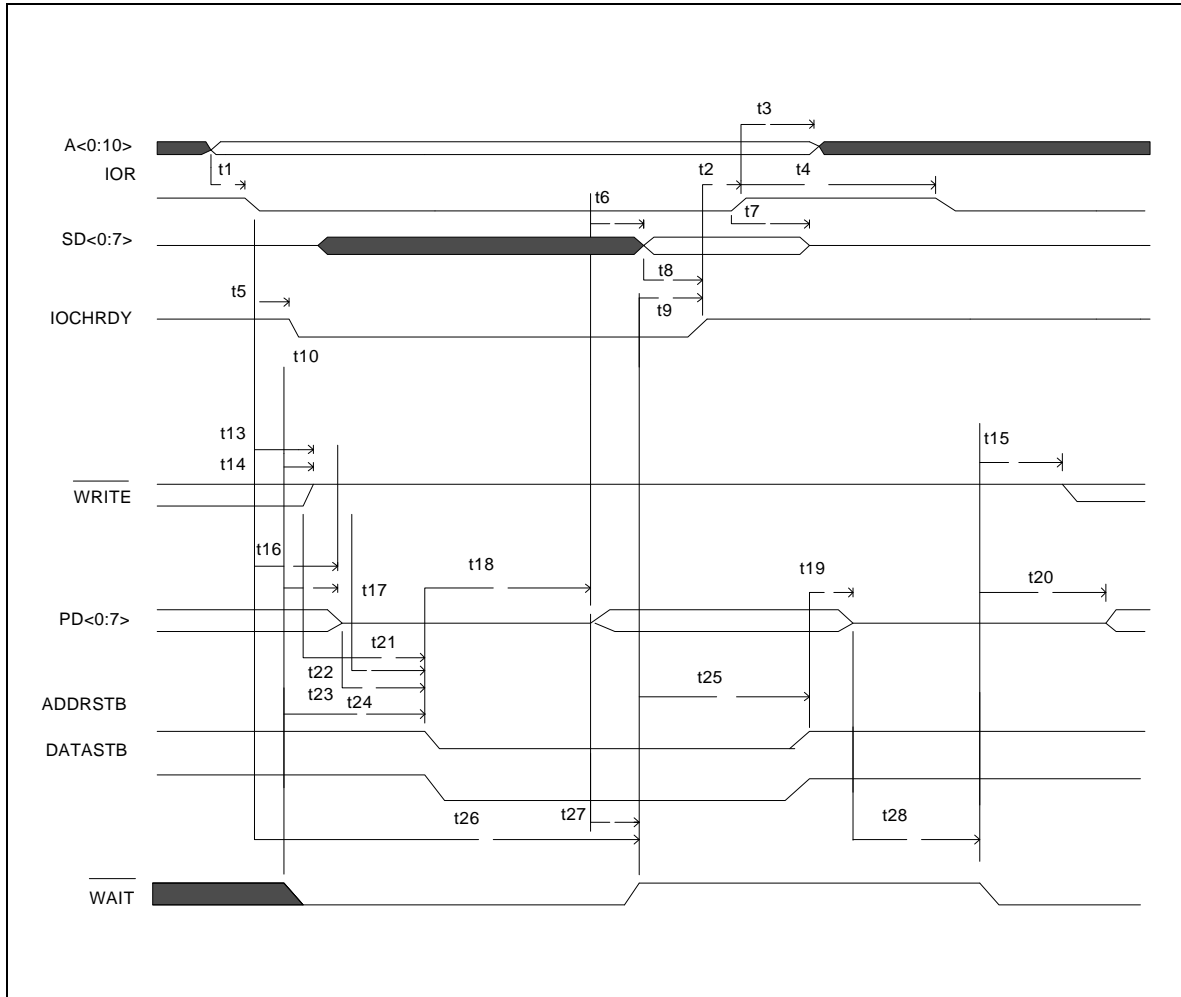

**EPP Data or Address Write Cycle (EPP Version 1.9)**

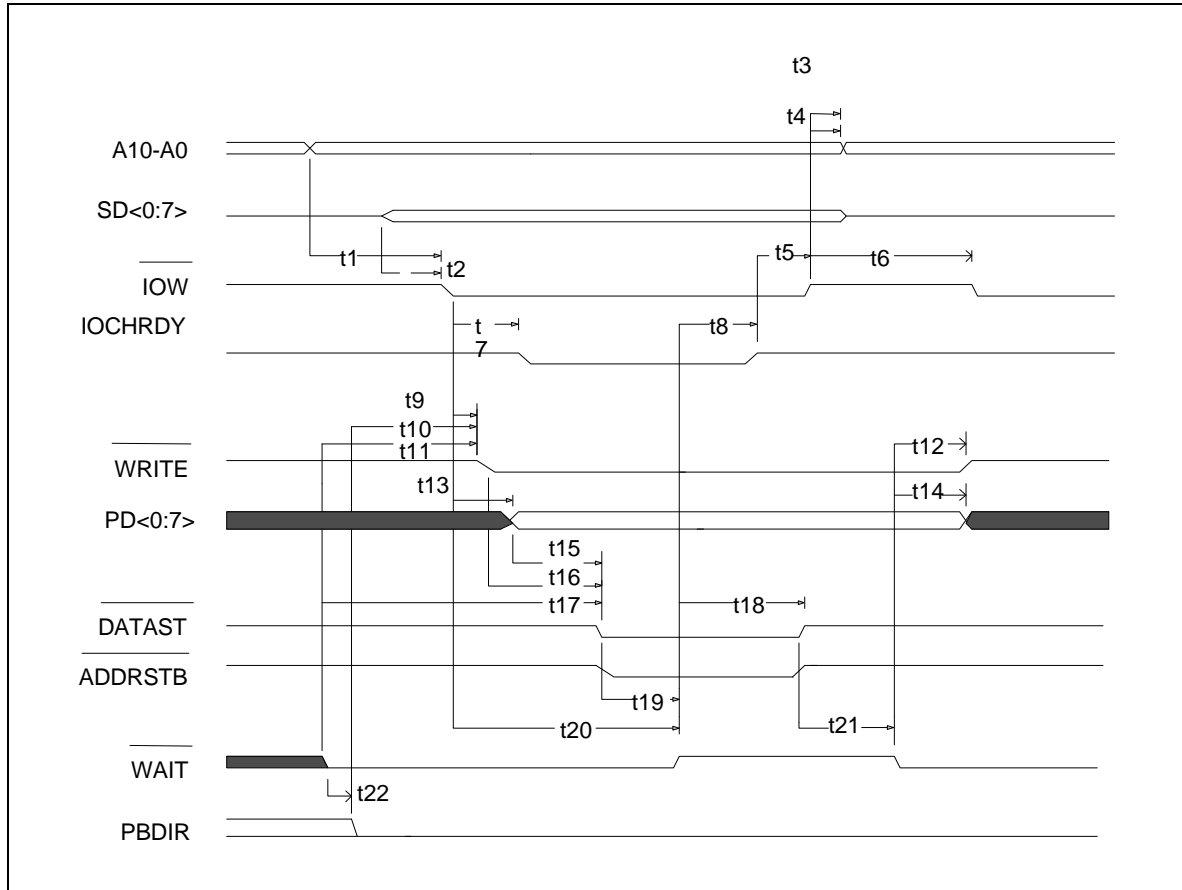

EPP Data or Address Read Cycle (EPP Version 1.7)

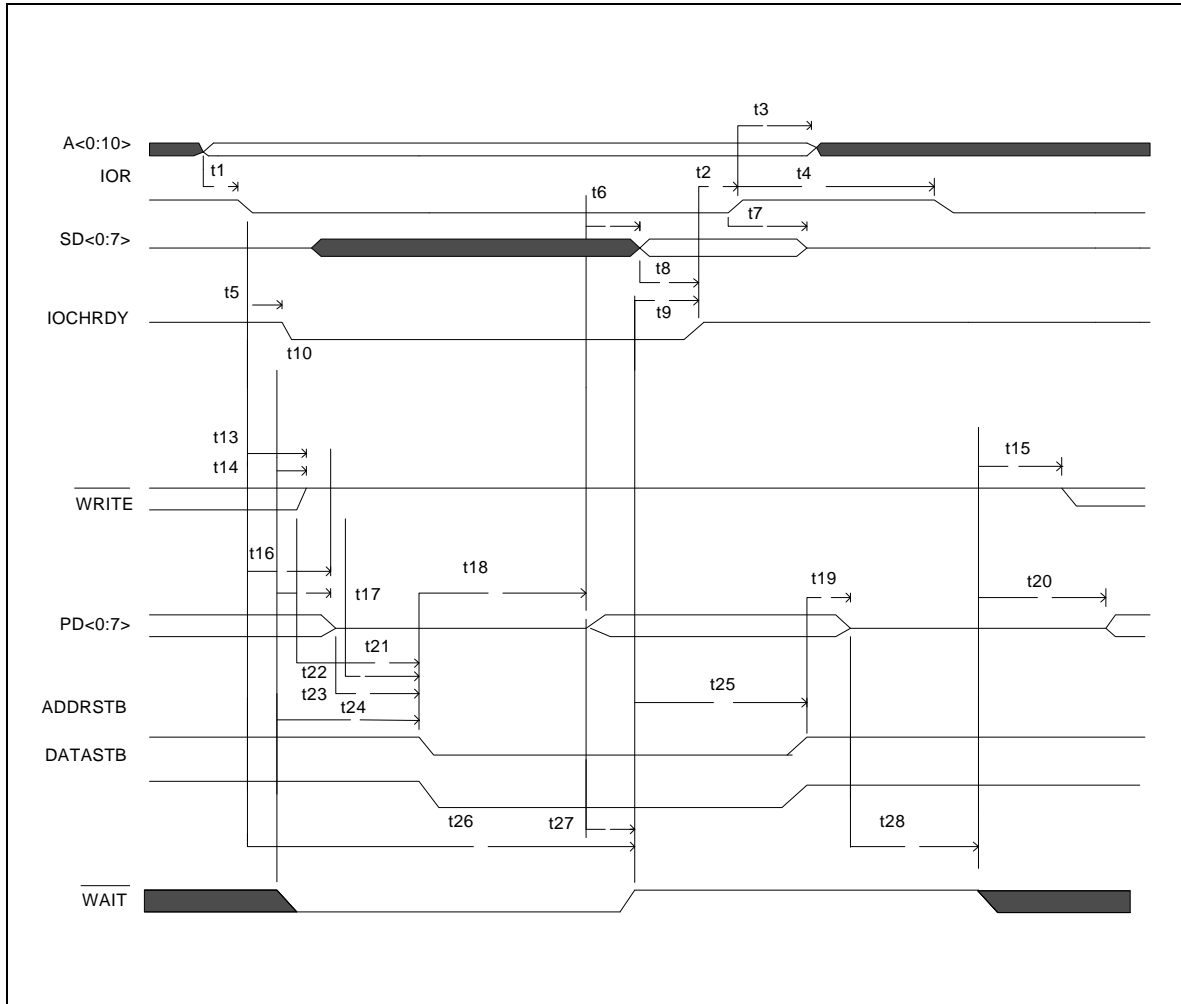

**EPP Data or Address Write Cycle (EPP Version 1.7)**

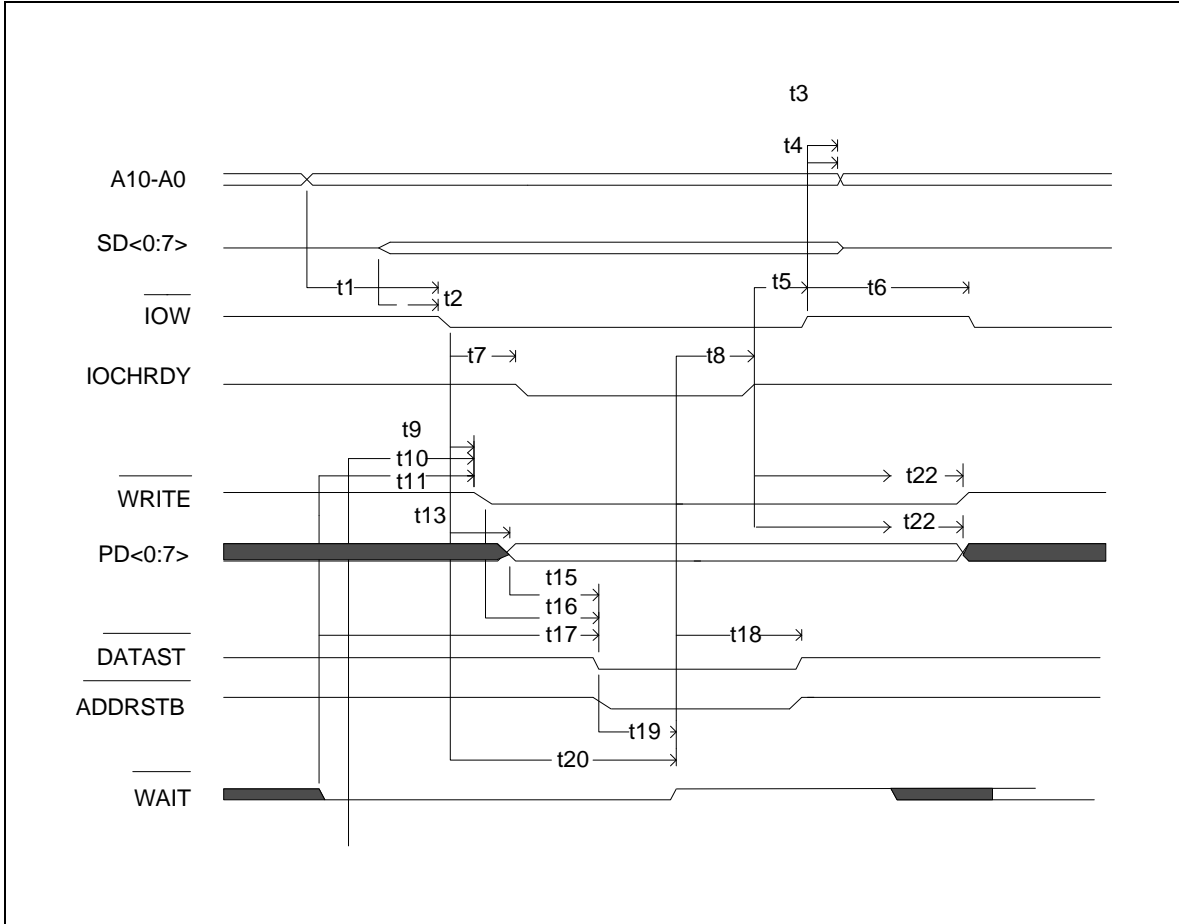

**Parallel Port FIFO Timing**

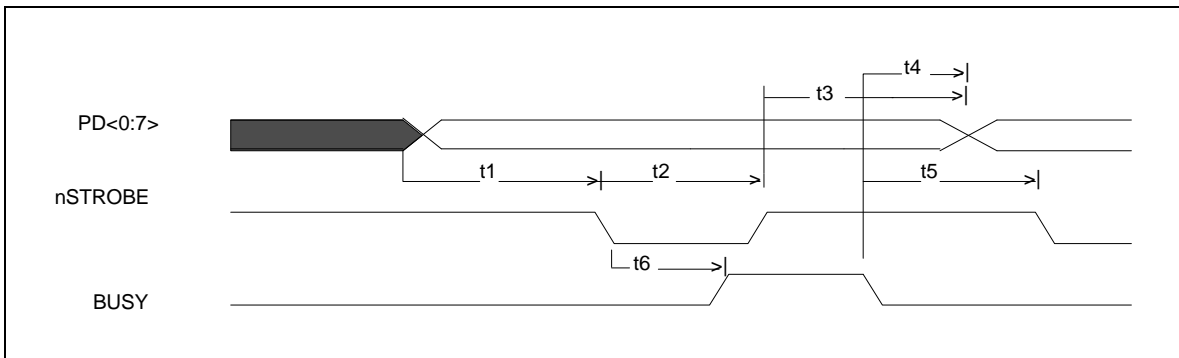

**ECP Parallel Port Forward Timing**

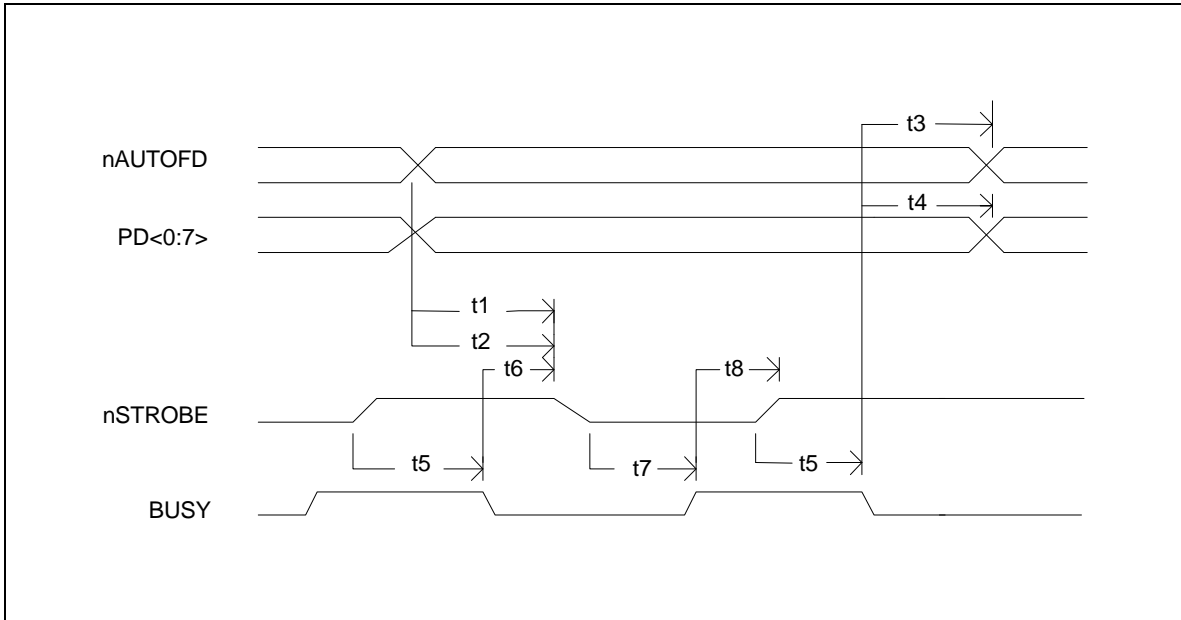

**ECP Parallel Port Reverse Timing**

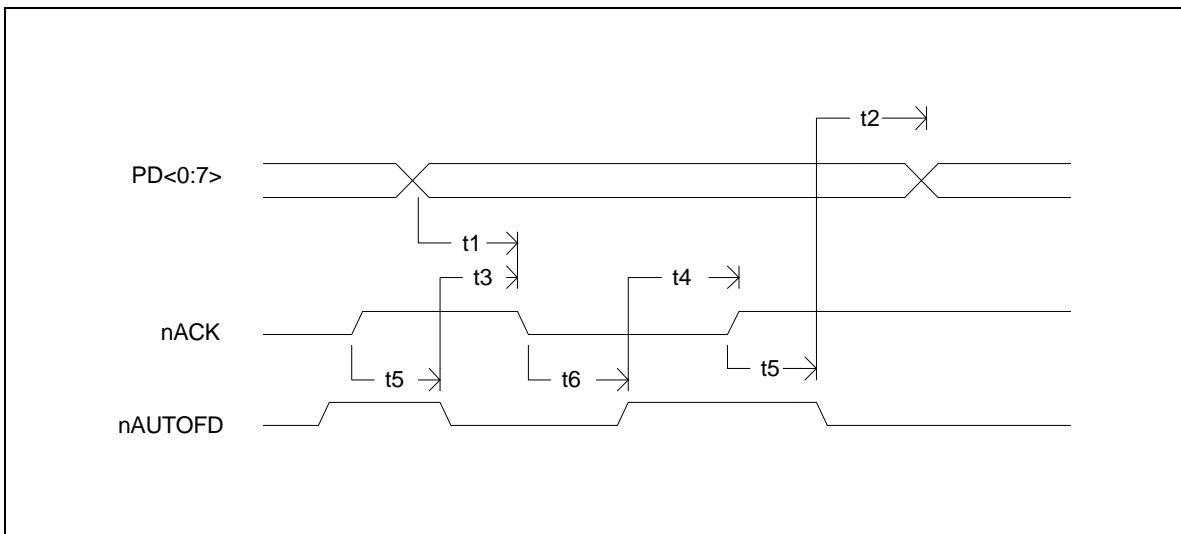

## 11.0 APPLICATION CIRCUITS

### 11.1 Parallel Port Extension FDD

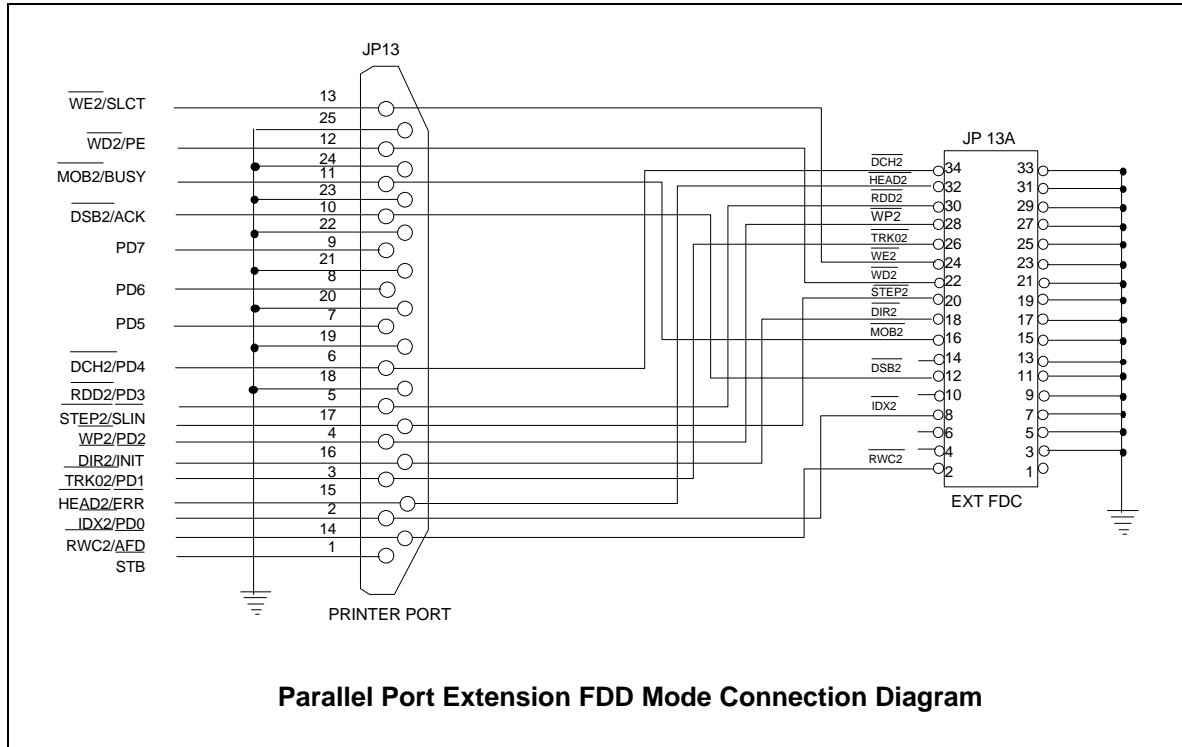

**11.2 Parallel Port Extension 2FDD**

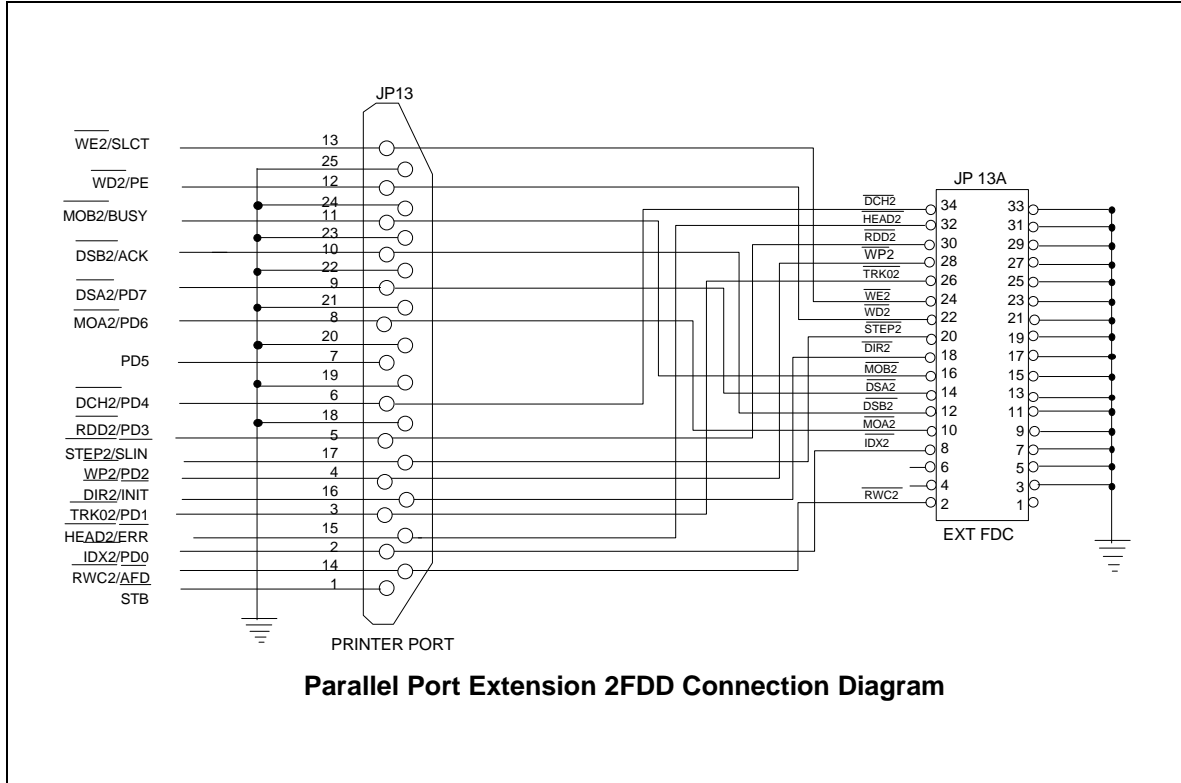

**11.3 Four FDD Mode**

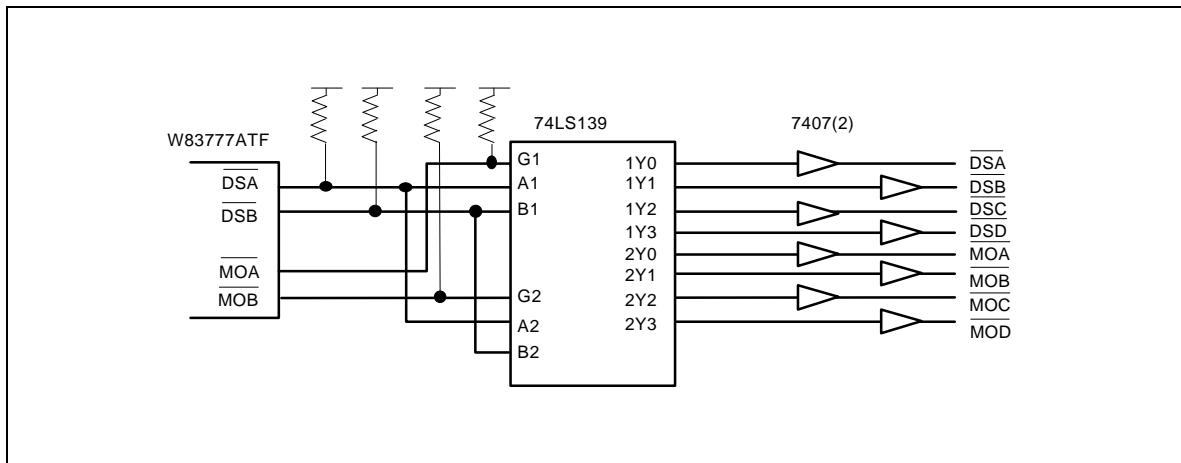

## 12.0 ORDERING INFORMATION

Part No.	Package
W83877ATF	100-pin QFP
W83877ATD	100-pin TQFP

## 13.0 HOW TO READ THE TOP MARKING

Example: The top marking of W83877ATF



1st line: Winbond logo

2nd line: the type number: W83877ATF

3rd line: the tracking code: 732 A C 2 7242968

732: packages made in '97, week 19

A: assembly house ID; A means ASE, S means SPIL ... etc

C: IC revision; B means version B, C means version C

2: wafers manufactured in Winbond FAB 2

7242968: wafer production series lot number

### 14.0 PACKAGE DIMENSIONS

#### W83877ATF (100-pin QFP)

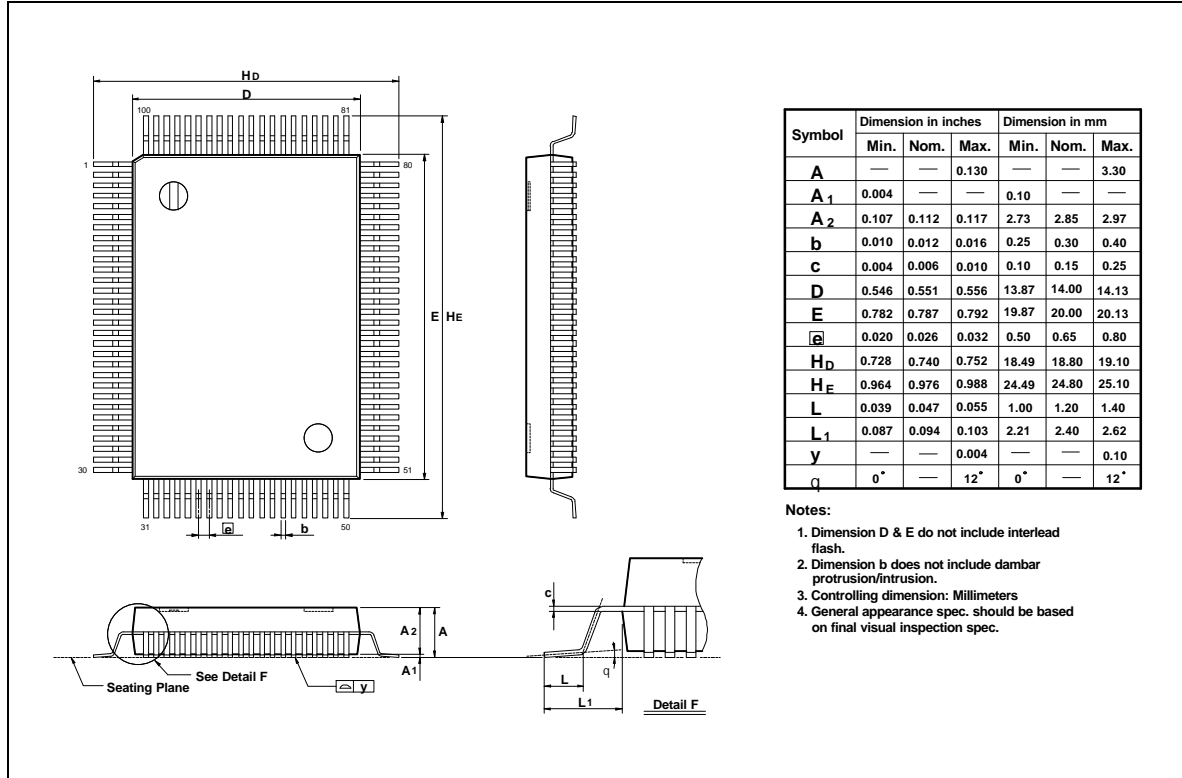

## W83877ATD (100-pin TQFP)

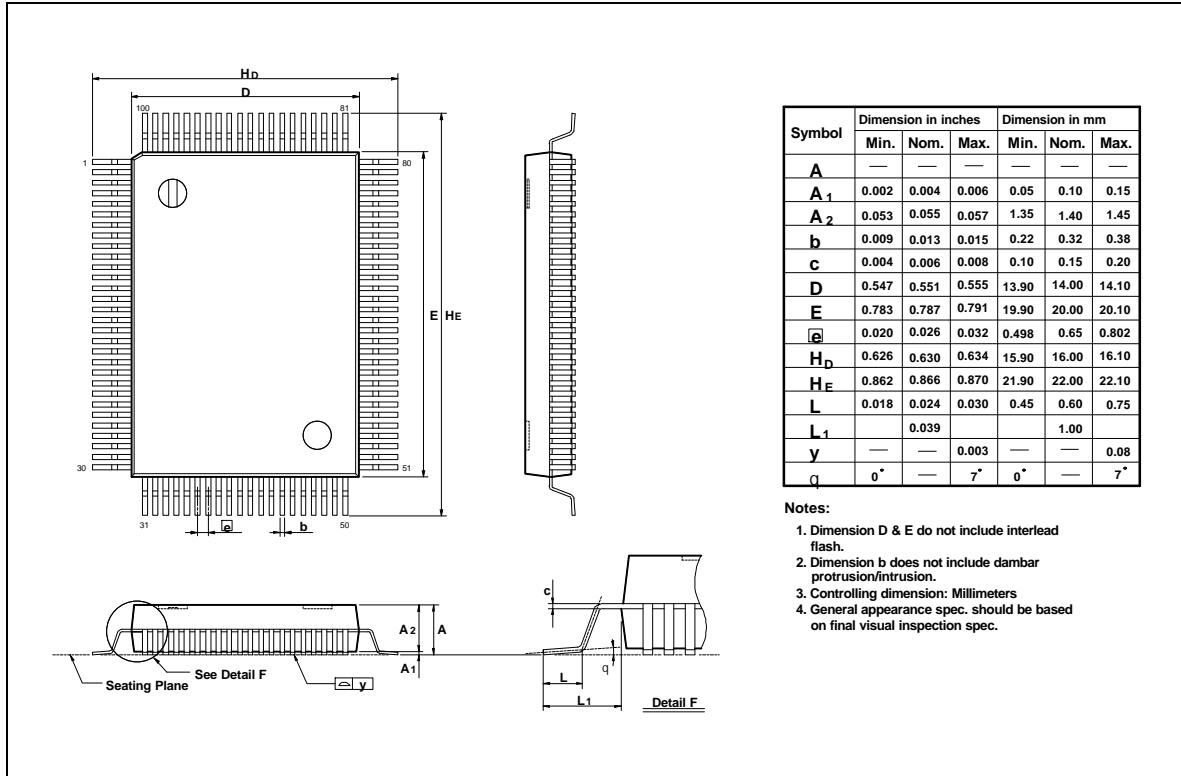

Please note that all data and specifications are subject to change without notice. All the trade marks of products and companies mentioned in this data sheet belong to their original owners.