

SICOFI[®]2- μ C

Two Channel Codec Filter with PCM and Microcontroller Interface

PEB 2266 Version 2.2

PEF 2266 Version 2.2

Wired
Communications



1 Overview

The two-channel codec filter PEB 2266 SICOFI[®]2- μ C is built around a central DSP-core which provides independent filter structures for all channels. Its analog I/O pins are used to connect to external subscriber line interface circuits (SLICs). Their signals are internally routed to the analog-to-digital and digital-to-analog converters (ADC, DAC). The signaling pins carry line status and control information to and from the SLICs. Two programmable clock outputs are available. The SICOFI[®]2- μ C connects to the digital switching and transmission system through two PCM Highways. The digitized voice band signals are available as A-Law or μ -Law codes within selectable 8-bit time slots.

The SICOFI[®]2- μ C modes, features, and filter characteristics are programmed through a serial interface to a microcontroller. The access mechanism is very simple, and can be implemented with as few as three I/O ports. The PEB 2266 is available for standard temperature range applications (0 °C to +70 °C); the PEF 2266 is available for extended temperature range applications (-40 °C to +85 °C).

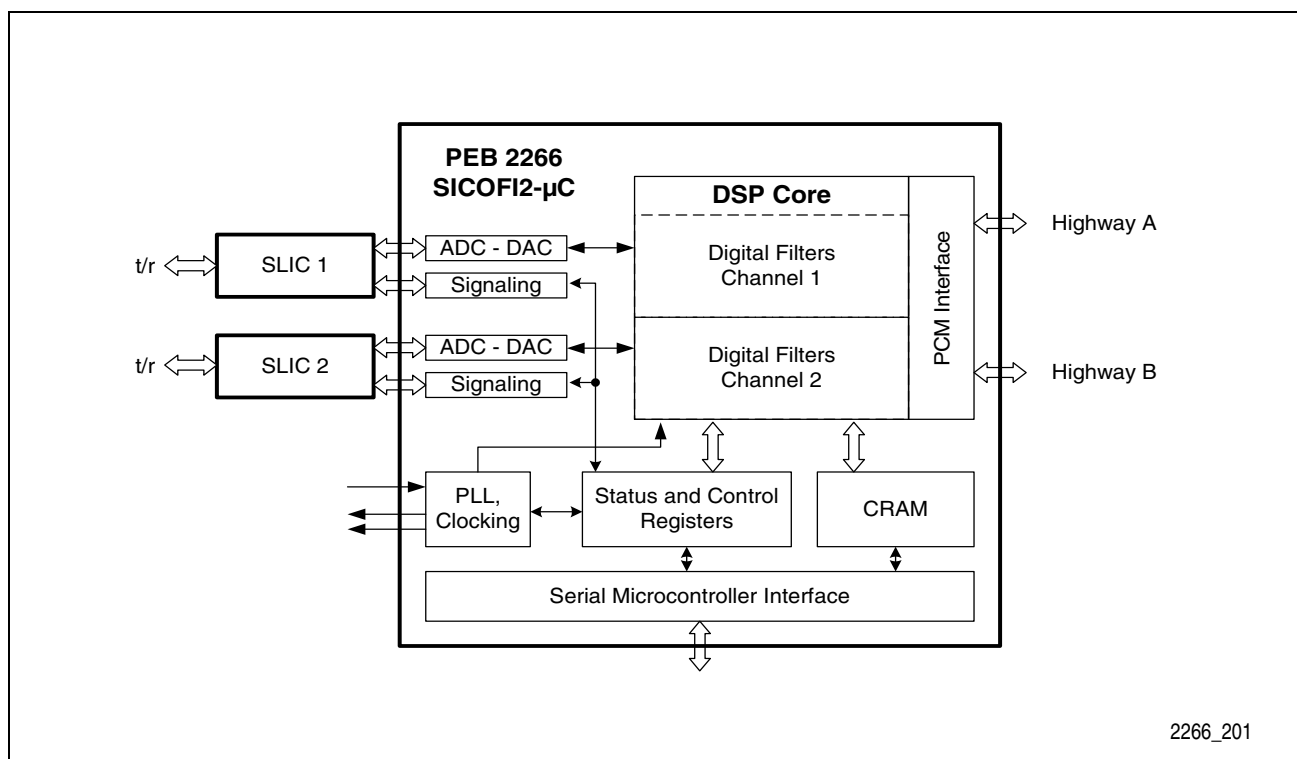

Figure 1 SICOFI[®]2- μ C Architecture

Two Channel Codec Filter with PCM and Microcontroller Interface SICOFI®2-μC

PEB 2266
PEF 2266

Version 2.2

CMOS

1.1 Features

- Two-channel single chip codec with digital filters
- High analog driving capability (300 Ω, 50 pF) for direct driving of transformers
- Digital Signal Processing (DSP) technique
- Programmable digital filters to adapt transmission behavior, especially for:
 - AC impedance matching
 - Transhybrid balancing
 - Frequency response
 - Signal levels
 - A/μ-Law compression and expansion
- Fulfills international (e.g. ITU-T Q.552, G.712) and country-specific requirements
- High performance ADC and DAC for excellent linearity and dynamic gain
- Programmable Analog Interface to electronic SLICs or transformer solutions
- Seven SLIC-signaling I/O pins per channel with programmable debouncing
- Two PCM Highways accessible by on-chip PCM Interface with Programmable time slot assignment and variable data rates from 128 kbit/s to 8 Mbit/s
- Easy to use 4-pin Serial Microcontroller Interface (SPI compatible) for read/write access
- Single supply voltage (5 V)
- Advanced low-power mixed-signal CMOS technology
- Two programmable tone generators (DTMF possible)
- Level metering function for system tests and for analog input signal testing
- Advanced on-chip functions for device and system diagnostics and manufacturing test
 - Five digital loops
 - Four analog loops
- Support tools include:
 - Hardware development board — STUT 2466
 - QSICOS Coefficient Calculation and Register Configuration Software
- Standard P-MQFP-64 package

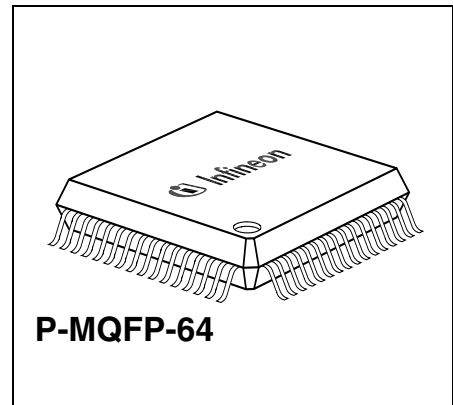

Type	Package
PEB 2266 Version 2.2	P-MQFP-64
PEF 2266 Version 2.2	P-MQFP-64

1.2 Logic Symbol

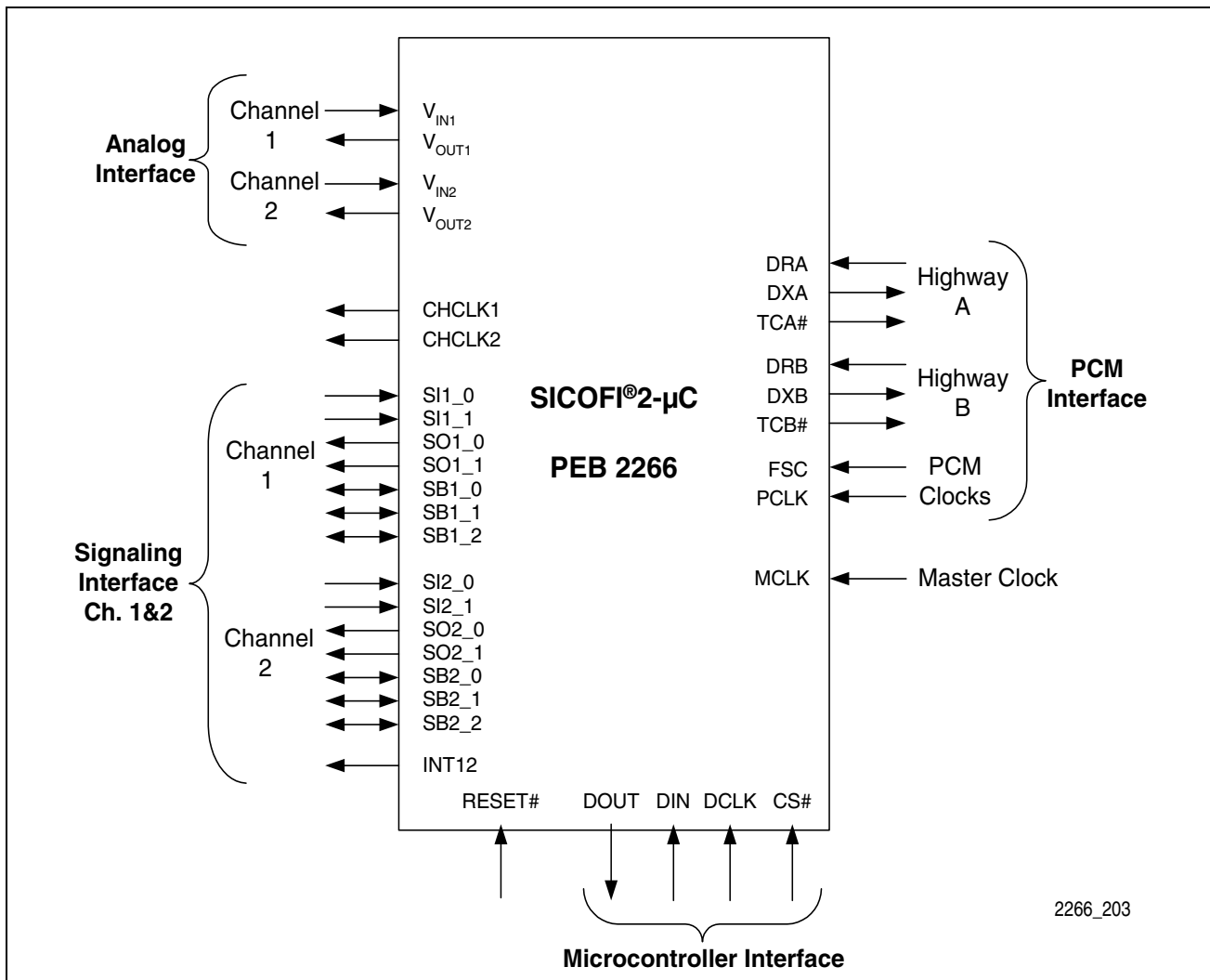

Figure 2 SICOFI®2-µC Logic Symbol

1.3 Typical Applications

Many applications will benefit from the versatility of the SICOFI®2-µC codec and filter. The inherent flexibility enables several products to be developed around one basic architecture, thus affording potentially significant savings in time to market, inventory costs, and support administration.

The following list represents some of the typical applications for which the SICOFI®2-µC codec was designed: Analog linecards for Central Offices and PBXs, Small PBX or Key Systems, Digital Loop Carrier (DLC) Systems, Digital Added Main Lines (DAML) Systems, Pair-Gain Systems, Fiber-to-the-Curb (FTTC) Systems, Radio-in-the-Loop (RITL) Systems, and

any Multi-channel, digital voice processing, storage, or communication applications. Refer to the **Product Overview, Chapter 5 Application Hints** for more information.

2 Pin Descriptions

2.1 Pin Diagram

(top view)

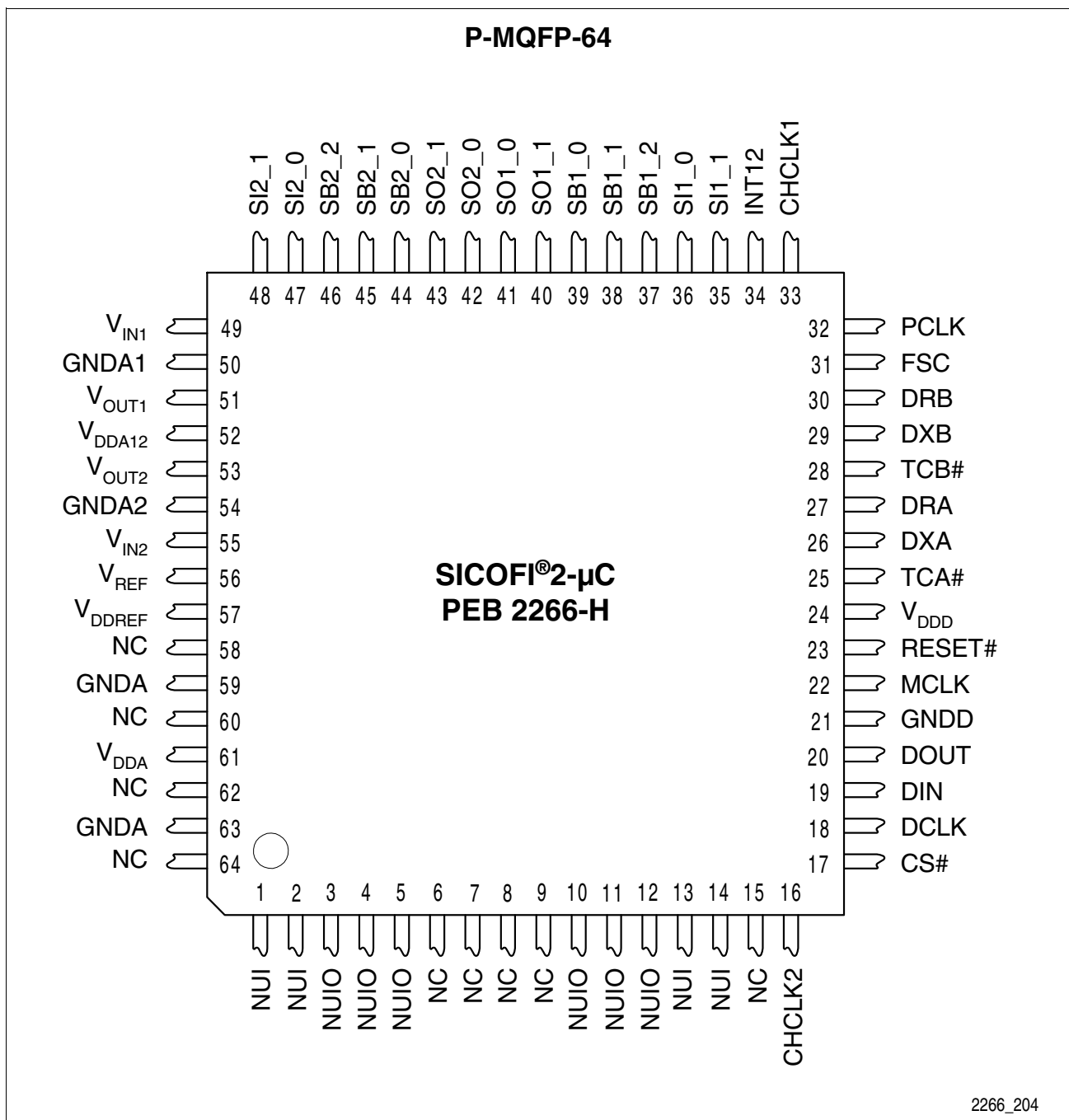

Figure 3 Pin Configuration of SICOFI®2-µC

2.2 Pin Definitions and Functions

Table 1 Pin Definitions and Functions

Pin	Symbol	Type	Function	Ch.
1, 2	NUI	I	Non Usable Input Pins tie directly to digital ground (Pin 21)	
3, 4, 5	NUIO	I/O	Non Usable Input/Output Pins tie via a pull-down-resistor to digital ground (Pin 21)	
6, 7, 8, 9	NC		Not Connected Pins not connected in this device.	
10, 11, 12	NUIO	I/O	Non Usable Input/Output Pins tie via a pull-down-resistor to digital ground (Pin 21)	
13, 14	NUI	I	Non Usable Input Pins tie directly to digital ground (Pin 21)	
15	NC		Not Connected Pins not connected in this device.	
16	CHCLK2	O	Chopper Clock Output 2 Provides 256, 512, or 16,384 kHz signal; sync. to MCLK.	both
17	CS#	I	Chip Select Microcontroller Interface chip select, enable to read or write; active low.	both
18	DCLK	I	Data Clock Microcontroller Interface data clock, shifts data from or to device; maximum clock rate 8192 kHz.	both
19	DIN	I	Data Input Microcontroller Interface control data input pin; DCLK determines data rate.	both
20	DOUT	O	Data Output Microcontroller Interface control data output pin; DCLK determines data rate: DOUT is high impedance "Z" if no data is transmitted from the SICOFI [®] 2- μ C.	both
21	GNDD	I	Digital Ground Ground reference for all digital signals. Internally isolated from GNDA1 (Pin 50), GNDA2 (Pin 54), and GNDA (Pins 59 and 63).	both

Pin Descriptions

Pin	Symbol	Type	Function	Ch.
22	MCLK	I	Master Clock Input 1536, 2048, 4096 or 8192 kHz must be applied for any operation (selected in Register XR5). MCLK, PCLK, FSC must be synchronous.	both
23	RESET#	I	Reset Input Forces the device to default setting mode; active low.	both
24	V _{DD}	I	Digital Supply Voltage +5 V supply for digital circuits (use 100 nF blocking cap.).	both
25	TCA#	O	Transmit Control Output A PCM Interface: active if data is transmitted via DXA; active low, open drain.	both
26	DXA	O	Data Transmit to PCM-Highway A PCM Interface: PCM data for each channel is transmitted in 8-bit bursts every 125 μ s.	both
27	DRA	I	Data Receive from PCM-Highway A PCM Interface: PCM data for each channel is received in 8-bit bursts every 125 μ s.	both
28	TCB#	O	Transmit Control Output B PCM Interface: active if data is transmitted via DXB; active low, open drain.	both
29	DXB	O	Data Transmit to PCM-Highway B PCM Interface: data for each channel is transmitted in 8-bit bursts every 125 μ s.	both
30	DRB	I	Data Receive from PCM-highway B PCM Interface: data for each channel is received in 8-bit bursts every 125 μ s.	both
31	FSC	I	Frame Synchronization Clock 8 kHz; reference for individual time slots, indicates start of PCM frame; MCLK, PCLK, FSC must be synchronous.	both
32	PCLK	I	PCM Data Clock 128 to 8192 kHz; determines the rate at which PCM data is shifted into or out of the PCM-ports. MCLK, PCLK, FSC must be synchronous.	both
33	CHCLK1	O	Chopper Clock Output 1 Provides programmable (2 ... 28 ms) output signal (synchronous to MCLK).	both

Pin Descriptions

Pin	Symbol	Type	Function	Ch.
34	INT12	O	Interrupt Output, Channels 1 and 2 Active high.	both
35	SI1_1	I	Signaling Input Channel 1, Pin 1	1
36	SI1_0	I	Signaling Input Channel 1, Pin 0	1
37	SB1_2	I/O	Bi-directional Signaling, Channel 1 Pin 2	1
38	SB1_1	I/O	Bi-directional Signaling, Channel 1 Pin 1	1
39	SB1_0	I/O	Bi-directional Signaling, Channel 1 Pin 0	1
40	SO1_1	O	Signaling Output, Channel 1, Pin 1	1
41	SO1_0	O	Signaling Output, Channel 1, Pin 0	1
42	SO2_0	O	Signaling Output, Channel 2, Pin 0	2
43	SO2_1	O	Signaling Output, Channel 2, Pin 1	2
44	SB2_0	I/O	Bi-directional Signaling, Channel 2 Pin 0	2
45	SB2_1	I/O	Bi-directional Signaling, Channel 2 Pin 1	2
46	SB2_2	I/O	Bi-directional Signaling, Channel 2 Pin 2	2
47	SI2_0	I	Signaling Input, Channel 2, Pin 0	2
48	SI2_1	I	Signaling Input, Channel 2, Pin 1	2
49	V _{IN1}	I	Analog Voice (Voltage) Input, Channel 1 Requires a coupling capacitor >39 nF to the SLIC.	1
50	GNDA1	I	Analog Ground, Channel 1 Not internally connected to GNDD or GNDA2 or GNDA.	1
51	V _{OUT1}	O	Analog Voice (Voltage) Output, Channel 1 Requires a coupling capacitor to the SLIC. The capacitor value depends on the SLIC's input impedance. (See Chapter 5.1 , "Analog Interface" on page 27).	1
52	V _{DDA12}	I	Analog Supply Voltage, Channels 1 and 2 +5 V (100 nF blocking capacitor required).	both
53	V _{OUT2}	O	Analog Voice (Voltage) Output, Channel 2 Requires a coupling capacitor to the SLIC. The capacitor value depends on the SLIC's input impedance. (See Chapter 5.1 , "Analog Interface" on page 27).	2
54	GNDA2	I	Analog Ground, Channel 2 Not internally connected to GNDD or GNDA1 or GNDA.	2
55	V _{IN2}	I	Analog Voice (Voltage) Input, Channel 2 Requires a coupling capacitor >39 nF to the SLIC.	2

Pin Descriptions

Pin	Symbol	Type	Function	Ch.
56	V_{REF}	I/O	Reference Voltage Must connect to a 220 nF cap. to ground.	both
57	V_{DDREF}	I	Analog Supply Reference Voltage +5 V (100 nF blocking capacitor required).	both
58	NC		Not Connected Pin not connected in this device.	
59	GNDA	I	Analog Ground Internally isolated from GNDD (Pin 21), GNDA1 (Pin 50), and GNDA2 (Pin 54).	
60	NC		Not Connected Pin not connected in this device.	
61	V_{DDA}	I	Analog Supply Voltage +5 V (100 nF blocking capacitor required).	
62	NC		Not Connected Pin not connected in this device.	
63	GNDA	I	Analog Ground Internally isolated from GNDD (Pin 21), GNDA1 (Pin 50), and GNDA2 (Pin 54).	
64	NC		Not Connected Pin not connected in this device.	

3 Functional Description

The telephone subscriber loop is a bi-directional two-wire line. The Subscriber Line Interface Circuit (SLIC) on the network side converts the two-wire interface to a four-wire interface which communicates with the SICOFI[®]2- μ C via separate receive and transmit signals, V_{IN} and V_{OUT} . The SLIC can be either a transformer or an electronic circuit with operational amplifiers. It must have a defined input impedance towards the subscriber line for maximum signal power transfer and return loss. The requirements for the input impedance vary from country to country and demand impedance matching to the different environments. Country-specific adaptations are also required for the transhybrid loss, which is a loss between the transmit and the receive ports of the two-wire to four-wire hybrid.

3.1 DSP-based Architecture

The impedance matching and transhybrid balancing functions are performed by loop filters between the transmit path (analog to PCM) and the receive path (PCM to analog). The filter characteristics must be adjusted according to the local requirements of each market. In the analog domain, filters must be optimized in hardware; this is generally both tedious and time-consuming. This is not the case with the DSP-based SICOFI[®]2- μ C two-channel codec. Its integrated signal processor implements the impedance matching and transhybrid balancing functions as digital, programmable filters. It also performs frequency response corrections and level adjustments to enable the design of a truly universal and internationally applicable telephone linecard. Transmission characteristics and frequency behavior are enhanced by the accuracy of the digital filters, which do not fluctuate over temperature or with age.

As an additional benefit of its DSP-based architecture, the PEB 2266 also provides two tone generators per channel. An on-chip level-metering unit allows line-characterization without extra hardware; it can also be used to detect specific tones, e.g., modem tones.

3.2 Programming and Control

A very simple Microcontroller Interface is used to program the SICOFI[®]2- μ C functions. The same port provides access to 14 general purpose I/O pins of the Signaling Interface. This allows efficient and convenient monitoring and control of other linecard functions, such as on-/off-hook detection, ground-key detection, switching of ring signals and test relays. The Serial Microcontroller Interface provides a programming and control interface and is generic and non-proprietary for use with any microcontroller. It can be implemented with as few as three signal lines, since the data receive and data transmit pins may be strapped together.

Figure 4 SICOFI[®]2- μ C Block Diagram

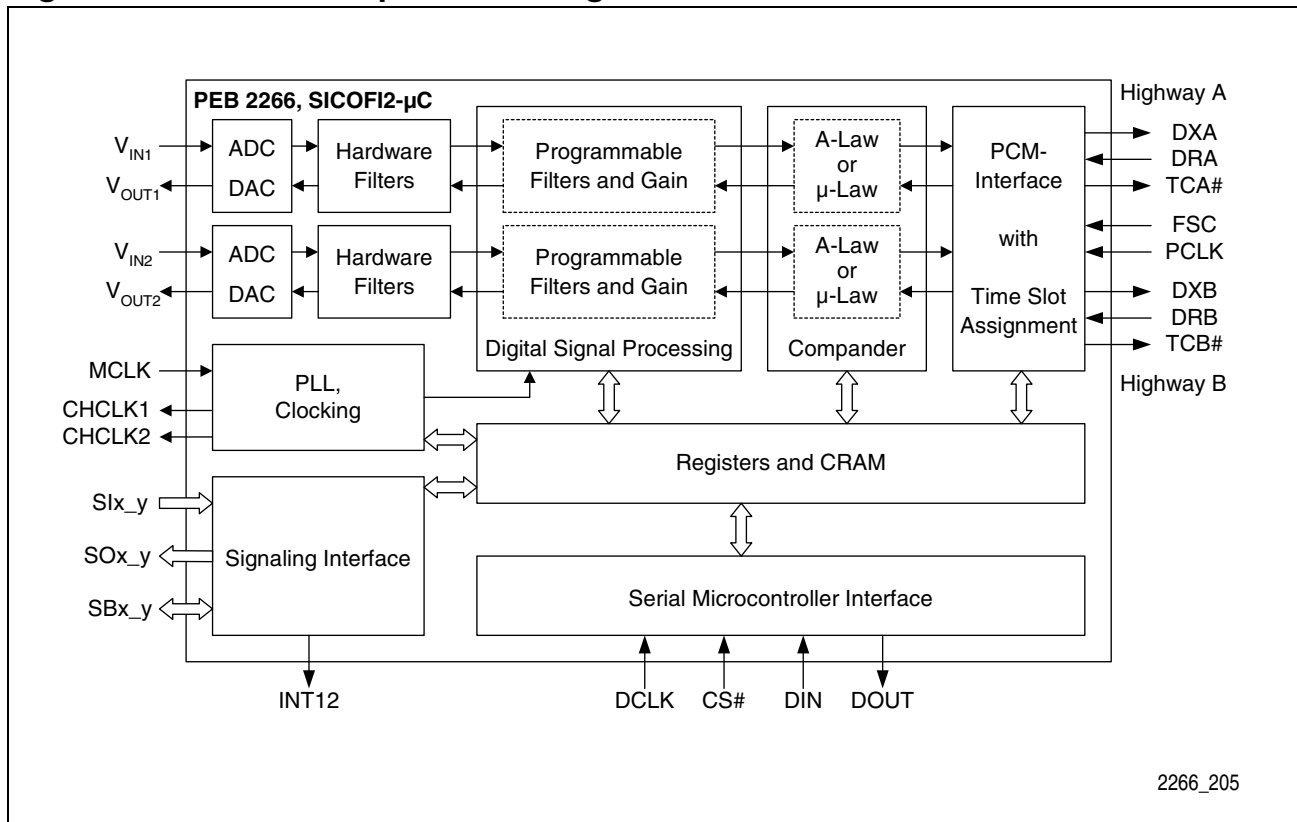

Figure 4 shows the functional blocks and the interface pins of the SICOFI[®]2- μ C:

- Two independent bi-directional voice channels;
- Oversampling sigma-delta A/D and D/A converters with excellent resolution, dynamic range, linearity, accuracy and signal-to-noise performance;
- Hardware filters for decimation and interpolation of the ADC and DAC bit stream, and pre-processing of the voice data to reduce the load of the DSP;
- DSP core with programmable, channel-independent filter structures for impedance matching, transhybrid balancing, frequency correction and level adjustments;
- Configurable A-Law or μ -Law compressor and expander units;
- Two PCM port with data rates from 128 kbps to 8 Mbps per highway;
- Programmable time slot assignment for each channel;
- Fourteen signaling input and output pins, accessible through registers;
- On-chip PLL for an internal 16,384 kHz clock;
- Two programmable versatile clock outputs;
- Eight common configuration registers (XR-Registers) affecting all two channels;
- Two sets of six channel-specific registers (CR-Registers); and
- Coefficient RAM (CRAM) for filter coefficients storage for each channel.

4 Operational Description

Each channel of the SICOFI[®]2- μ C can be in one of two stable states: “Standby” and “Operating”. These states can be switched by programming Bit 0 (PU) in the channel-specific configuration register CR1. “Standby” is a power-saving state. Keeping any unused channels in this state reduces the overall system power dissipation. The third state, “Reset”, is transient and is reached after applying power to the device (Power On), after asserting a logic low signal to the RESET#-pin (HW-Reset), or after issuing an XOP command with Bit 7 (RST) set to “1” (SW-Reset). Both channels would be affected in any case.

4.1 Operating States

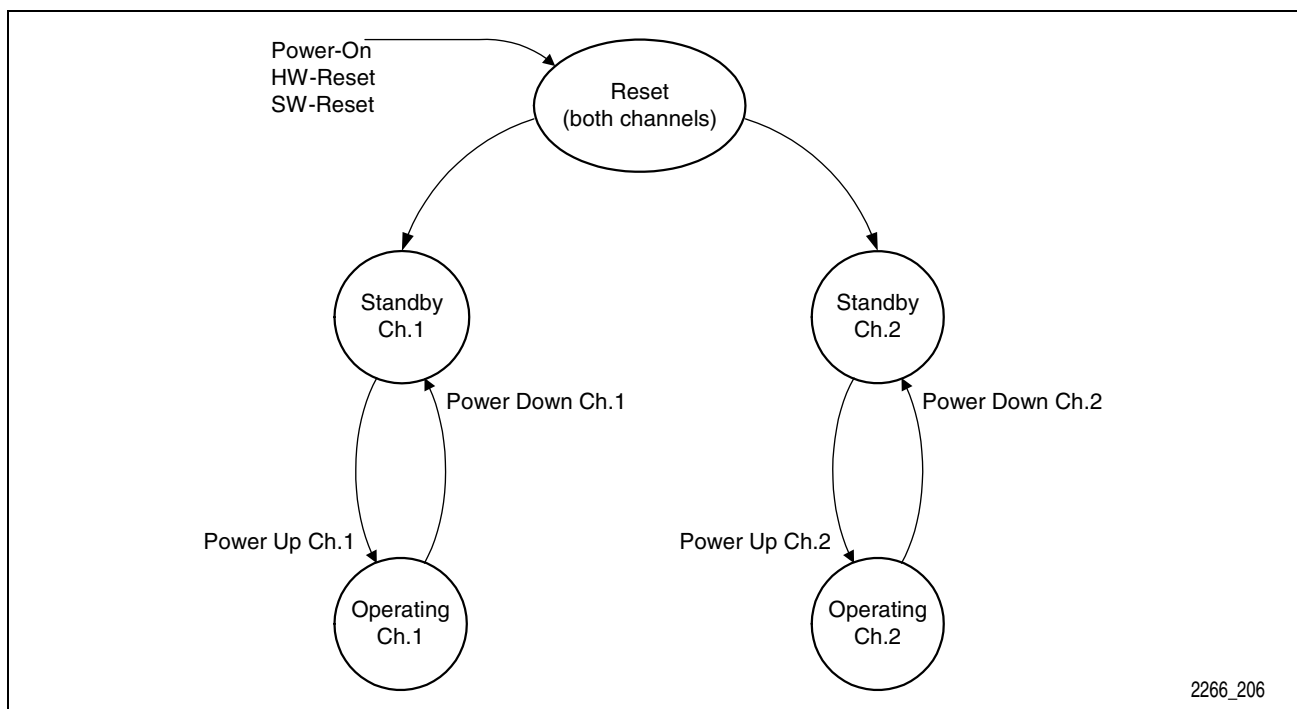

Figure 5 SICOFI[®]2- μ C State Diagram

4.1.1 Power On

All input pins must be at GND level before applying VDD to the SICOFI[®]2- μ C. Otherwise, the device may not enter the Reset State. In this case, the SICOFI[®]2- μ C can be reset by HW- or SW-Reset, or can be initialized by setting all registers to zero.

4.1.2 Hardware Reset

Voltage levels lower than 1.2 V applied to Pin 23 (RESET#) for more than 3 μ s will reset the SICOFI[®]2- μ C. Spikes that are shorter than 1 μ s will be ignored. When RESET# is released the SICOFI[®]2- μ C will enter Standby State.

Operational Description

Table 2 Register Values and Accessibility

Register	SICOFI®2-μC State		
	Reset	Standby	Operating
CR0 ... CR4	00 _H	user configurable	user configurable
XR0 ... XR7	00 _H	user configurable	user configurable
CRAM	unchanged	user configurable	user configurable

Table 3 Input and Output Pin Behavior

Pin	SICOFI®2-μC State		
	Reset	Standby	Operating
DIN	ignored	serial input	serial input
DOUT	high impedance	serial output	serial output
DRA, DRB	ignored	ignored	active receive time slot
DXA, DXB	high impedance	high impedance	active transmit time slot
TCA#, TCB#	high	high	low during active transmit time slot
V _{OUT1} , V _{OUT2}	high impedance	high impedance	analog output
V _{IN1} , V _{IN2}	ignored	ignored	analog input
SBx_y	configured as input	programmable as input or output	programmable as input or output
SOx_y	GNDD	digital output	digital output
Slx_y	ignored	digital input	digital input
CHCLK1	high	programmable frequency	programmable frequency
CHCLK2	high	programmable freq. (not 16,384 kHz)	programmable frequency

Table 4 Power Dissipation

No. of Channels Operating	Typical Power Dissipation
None	2.5 mW
1	70 mW
2	90 mW

4.2 Transmission Characteristics

4.2.1 Overload Point

The overload point of the SICOFI[®]2- μ C A/D converters is at 2.223 V. This is the peak amplitude of a sine wave level of 1.572 Vrms. Higher input signal levels will be distorted. Theoretical load capacities for A-Law and μ -Law encoded signals are defined in ITU-T Recommendation G.711. These values correspond to the SICOFI[®]2- μ C overload point:

Table 5 Maximum Signal Levels

Encoding Law	PCM Interface	Analog Interface
	Theoretical Load Capacity (according to ITU-T G.711)	Max. Sine Wave Level (SICOFI [®] 2- μ C Overload Point)
A-Law	3.14 dBm0	1.572 Vrms
μ -Law	3.17 dBm0	

4.2.2 0 dBm0-Levels

The analog voltage levels corresponding to a 0 dBm0 sine wave signal can be calculated from the maximum signal levels shown in **Table 5**. The results are shown in **Table 6**.

Table 6 Analog Voltage Levels Corresponding to 0 dBm0-Level

Encoding Law	Analog Sine Wave Level corresponding to 0 dBm0 PCM Level
A-Law	$1.572 \text{ Vrms} * 10^{(-3.14/20)} = 1.095 \text{ V rms}$
μ -Law	$1.572 \text{ Vrms} * 10^{(-3.17/20)} = 1.091 \text{ V rms}$

Note: Periodic PCM codes for a 1 kHz sine wave signal with 0 dBm0 level can be found in ITU-T G.711.

4.2.3 Compressor Gain Relative to Coding Law

The μ -Law compressor unit of the SICOFl[®]2- μ C automatically adds 1.94 dB gain, which has to be considered for the total gain calculation. The accumulated gain of all programmable transmit filters (AX1+AX2+FRX) must not exceed 7 dB if the device is set to μ -Law operation. If the device is set to A-Law operation, then the accumulated gain must not exceed 9 dB.

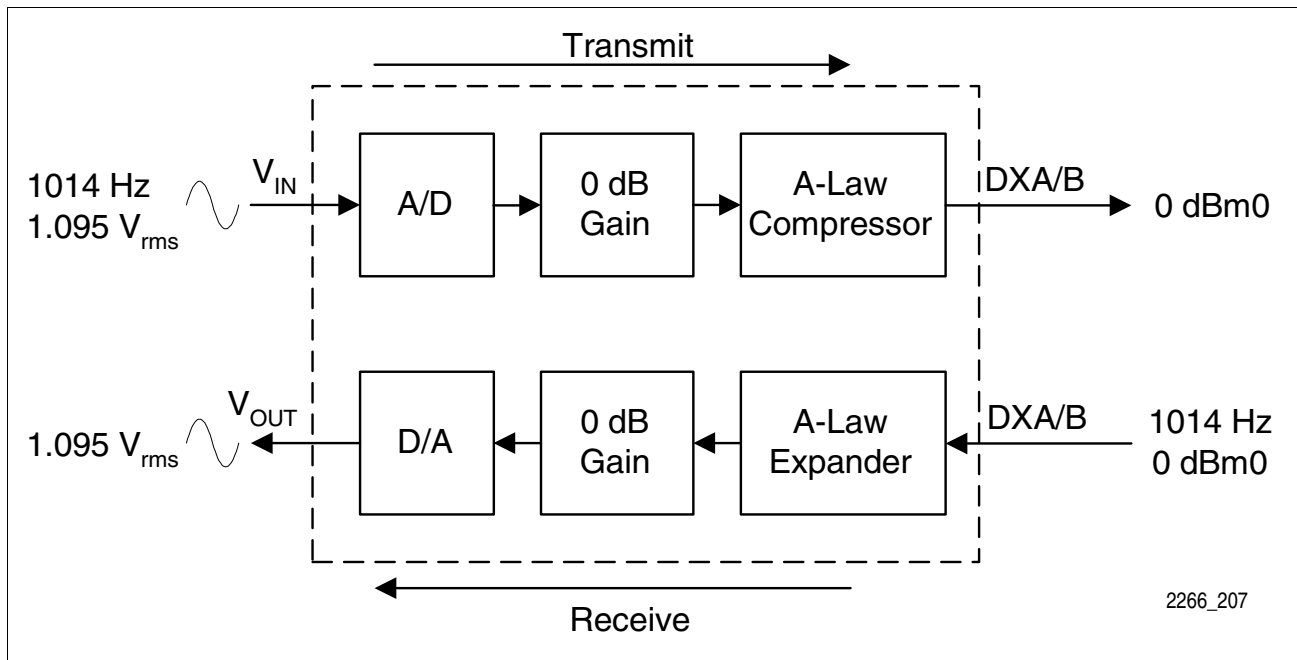

Figure 6 Analog and PCM Signal Levels in A-Law Mode

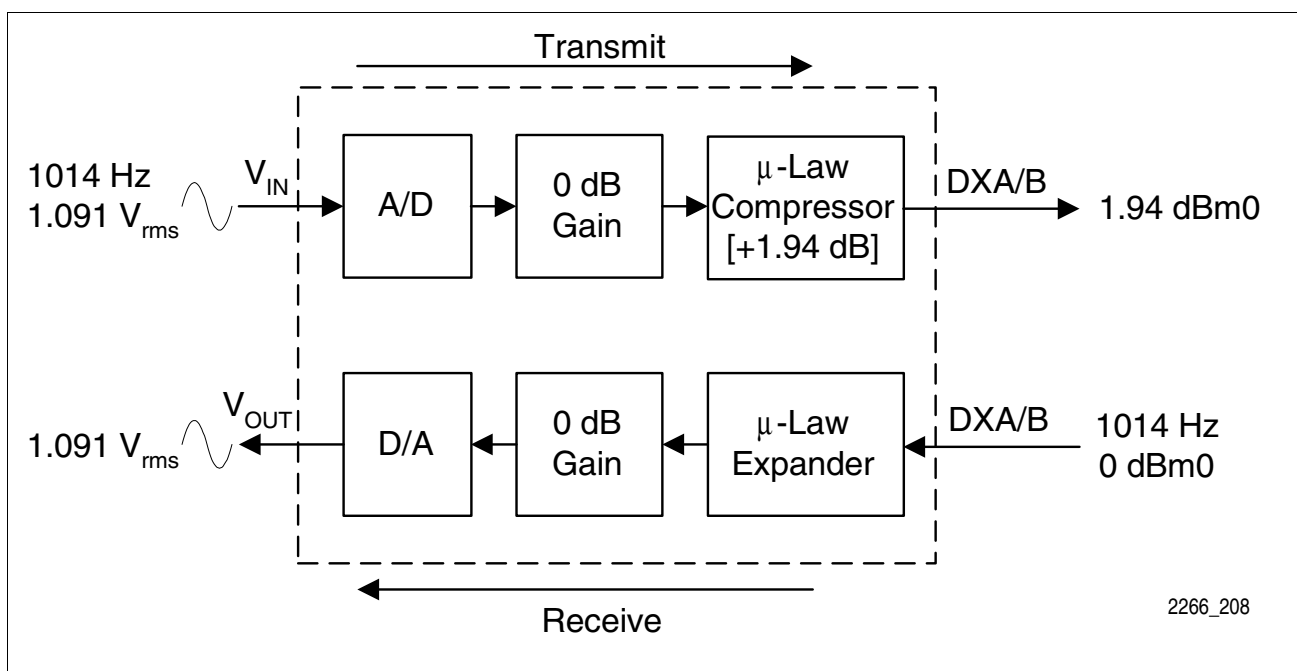

Figure 7 Analog and PCM Signal Levels in μ -Law Mode

4.2.4 Operating Conditions

The specifications to which the SICOFI[®]2- μ C are tested are tighter than the ITU-T Q.552 Specification to guardband various SLIC implementations. The guaranteed transmission characteristics of the SICOFI[®]2- μ C under test conditions ensure that the final linecard design will meet the ITU-T specification.

The figures in this document are based on the subscriber-line board requirements. Proper adjustment of the programmable filters (transhybrid balancing, impedance matching, frequency-response correction) requires a complete knowledge of the analog environment in which the SICOFI[®]2- μ C is to be used. Unless otherwise stated, the transmission characteristics are guaranteed within the following operating conditions:

- $T_A = 0\text{ }^{\circ}\text{C}$ to $70\text{ }^{\circ}\text{C}$ (**PEB 2266**), $T_A = -40\text{ }^{\circ}\text{C}$ to $85\text{ }^{\circ}\text{C}$ (**PEF 2266**);
- $V_{DD} = 5\text{ V} \pm 5\%$;
- $\text{GNDA}_{1,2,3,4} = \text{GNDD} = 0\text{ V}$;
- Load on V_{OUT} : $R_L > 300\ \Omega$; $C_L < 50\text{ pF}$;
- $H(\text{IM}) = H(\text{TH}) = 0$;
- $H(\text{R1}) = H(\text{FRX}) = H(\text{FRR}) = 1$;
- HPR and HPX enabled;
- $\text{AR} = 0$ to -9 dB ($\text{AR} = \text{AR1} + \text{AR2} + \text{FRR} + \text{R1}$);
- $\text{AX} = 0$ to $+9\text{ dB}$ for A-Law,
 $\text{AX} = 0$ to $+7\text{ dB}$ for μ -Law ($\text{AX} = \text{AX1} + \text{AX2} + \text{FRX}$);
- $f = 1014\text{ Hz}$; 0 dBm_0 ; A-Law or μ -Law;
- $\text{AGX} = 0\text{ dB}$, $+6.02\text{ dB}$; and
- $\text{AGR} = 0\text{ dB}$, -6.02 dB .

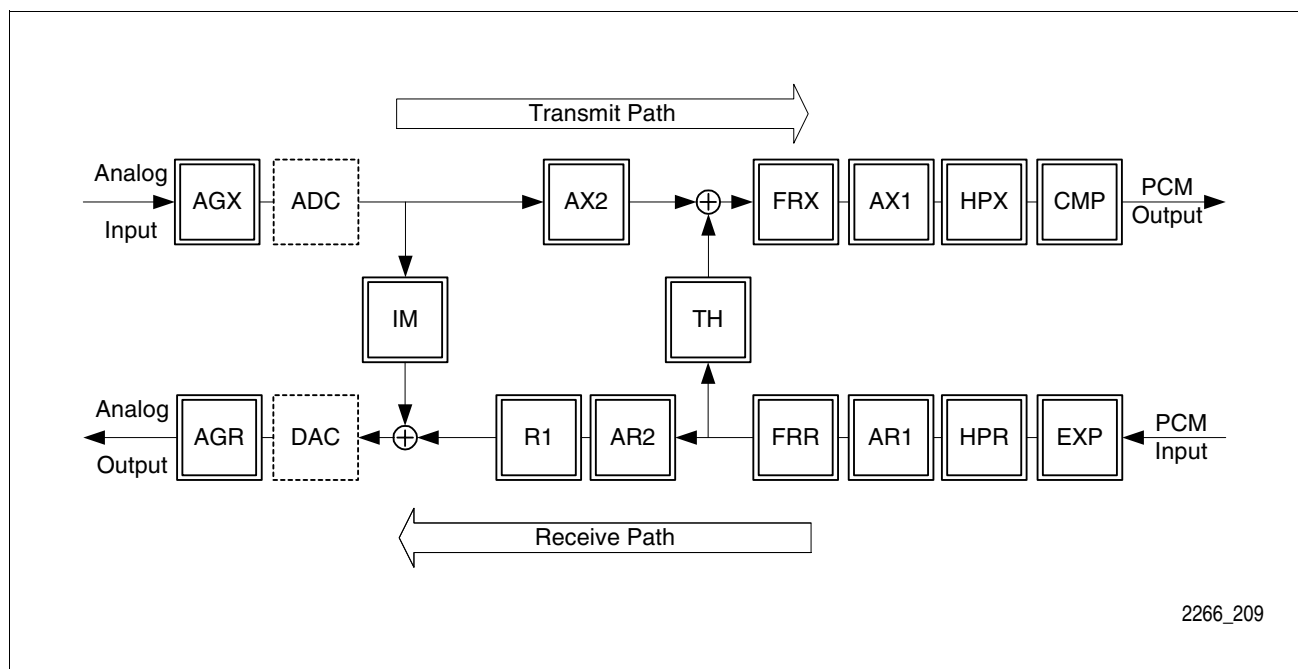

Figure 8 Simplified Signal Flow Diagram

4.2.5 Gain Accuracy

Table 7 Gain Accuracy

Parameter	Symbol	Limit Values			Unit	Test Conditions
		min.	typ.	max.		
Absolute Gain	G	-0.20	± 0.10	+0.20	dB	$T_A = 25\text{ }^\circ\text{C}$, $V_{DD} = 5\text{ V}$, AGX = AGR = 0 dB
Variation with Temperature				± 0.05	dB	$T_A = -40\text{ }^\circ\text{C}$ to $85\text{ }^\circ\text{C}$
Variation with Supply Voltage				± 0.05	dB	$V_{DD} = 5\text{ V} \pm 5\%$
Variation with Analog Gain				± 0.05	dB	AGX= +6.02 dB, AGR= -6.02 dB

4.2.6 Gain Tracking (Receive and Transmit)

The gain deviation for a 1014 Hz sine-wave input signal will stay within limits shown in **Table 8**. All values are relative to the gain of a 0 dBm0 input signal.

Table 8 Gain Deviations with Input Level

Input Level	Symbol	Gain Deviation			Unit	Test Conditions
		min.	typ.	max.		
-55 to -50 dBm0	ΔG			± 1.4	dB	1014 Hz sine-wave test signal. Reference level is at 0 dBm0.
-50 to -37 dBm0	ΔG			± 0.5	dB	
-37 to 3 dBm0	ΔG			± 0.25	dB	

4.2.7 Frequency Response

Table 9 Attenuation with Frequency in Transmit and Receive Direction

Input Frequency	Receive Loss		Transmit Loss		Unit	Test Conditions
	min.	max.	min.	max.		
0 Hz to 100 Hz	0		> 2		dB	0 dBm0 input signal level. 1014 Hz reference frequency
100 Hz to 200 Hz	0		0		dB	
200 Hz to 300 Hz	-0.125		-0.125	1	dB	
300 Hz to 3.0 kHz	-0.125	0.125	-0.125	0.125	dB	
3.0 kHz to 3.2 kHz	-0.125	0.3	-0.125	0.3	dB	
3.2 kHz to 3.4 kHz	-0.125	0.65	-0.125	0.65	dB	
> 3.4 kHz	0		0		dB	

4.2.8 Group Delay

4.2.8.1 Group Delay, Absolute Values

Table 10 shows the limit values for the Absolute Group Delay. The maximum delays are valid when the SICOFI[®]2- μ C is operating with $H(\text{TH}) = H(\text{IM}) = 0$, and $H(\text{FRR}) = H(\text{FRX}) = 1$, and include the delay through the A/D and D/A converters. The typical delays are the average of all different time slot delays during one PCM frame.

Table 10 Group Delay, Absolute Values

Parameter	Symbol	Limit Values			Unit	Test Conditions
		min.	typ.	max.		
Transmit Delay	D_{XA}	300	375	450	μs	0 dBm0 input signal level, f_{Test} at $T_{\text{G min}}$.
Receive Delay	D_{RA}	300	375	450	μs	

4.2.8.2 Group Delay Distortion with Frequency

The Group Delay Distortion in transmit and receive direction will stay within the limits shown in **Table 11**. Group Delay Distortion values are referenced to the minimum value of Group Delay (T_{Gmin}).

Table 11 Group Delay Distortion with Frequency

Frequency	Symbol	Limit Values			Unit	Test Conditions
		min.	typ.	max.		
500 Hz to 600 Hz	Δt_G			300	μs	0 dBm0 input signal level, reference point is at T_{Gmin} .
600 Hz to 1.0 kHz	Δt_G			150	μs	
1.0 kHz to 2.6 kHz	Δt_G			100	μs	
2.6 kHz to 3.0 kHz	Δt_G			300	μs	

4.2.9 Noise

Table 12 Idle Channel Noise in Transmit Direction

Parameter	Symbol	Limit Values			Unit
		min.	typ.	max.	
A-Law, psophometric ($V_{IN} = 0 V$)	N_{TP}			-67.4	dBm0p
μ -Law, C-message ($V_{IN} = 0 V$)	N_{TC}			17.5	dBmc
μ -Law, C-message ($V_{IN} = 0 V$)	N_{TC}			17.5	dBrnC0

Table 13 Idle Channel Noise in Receive Direction

Parameter	Symbol	Limit Values			Unit
		min.	typ.	max.	
A-Law, psophometric (idle code + 0)	N_{RP}		-85	-78.0	dBm0p
μ -Law, C-message (idle code + 0)	N_{RC}		5	12.0	dBmc
μ -Law, C-message (idle code + 0)	N_{RC}		5	12.0	dBrnC0

4.2.10 Harmonic and Intermodulation Distortion

Table 14 Harmonic and Intermodulation Distortion

Parameter	Symbol	Limit Values			Unit	Test Conditions
		min.	typ.	max.		
Harmonic Distortion 2 nd , 3 rd order	<i>HD</i>		-50	-44	dB	0 dBm0; <i>f</i> = 1014 Hz
Intermodulation	<i>R</i> ₂ <i>IMD</i>			-46	dB	Equal-level, 4-tone method (EIA-464) at composite level of -13 dBm0; <i>f</i> = 300 Hz to 3400 Hz
	<i>R</i> ₃ <i>IMD</i>			-56	dB	

4.2.11 Total Distortion

Table 15 Signal-to-Total Distortion Ratio Measured with Sine Wave

Input Level	Symbol	Min. Values		Unit	Test Conditions
		A-Law	μ -Law		
-45 dB	S/D	24.5	27	dB	sine wave <i>f</i> =1014 Hz, receive and transmit, μ-Law: C-message weighted, A-Law: psophometrically weighted.
-40 dB	S/D	29.5	31	dB	
-30 dB	S/D	35.5	35.5	dB	
> -28 dB	S/D	36.4	36.4	dB	

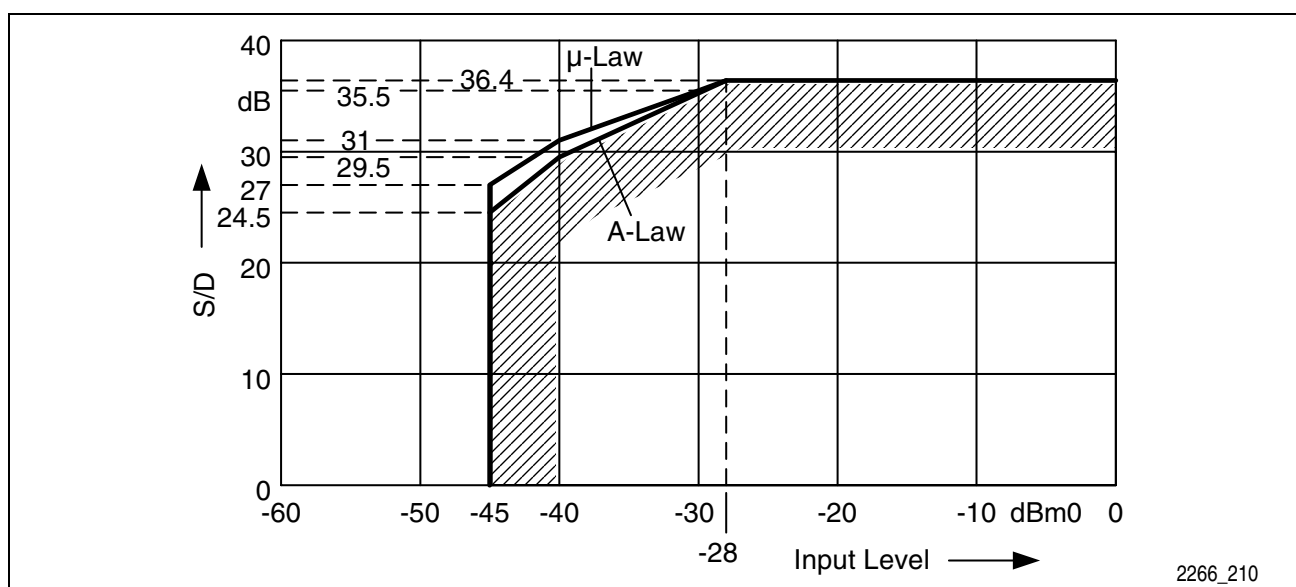

Figure 9 Total Distortion Measured with Sine-Wave, Receive and Transmit

Table 16 Signal-to-Total Distortion Ratio Measured with Noise

Input Level	Symbol	Min. Value, PEB 2266		Min. Value, PEF 2266		Unit
		Receive	Transmit	Receive	Transmit	
-55 dB	S/D	14.7	13.7	14.7	12	dB
-40 dB	S/D	29.7	28.7	29.7	27	dB
-34 dB	S/D	34.3	33.3	34.3	33.3	dB
-27 dB	S/D	36	35.4	36	35.4	dB
-24 to -6 dB	S/D	36.7	36.3	36.7	36.3	dB
-3 dB	S/D	28.4	27.4	28.4	27.4	dB

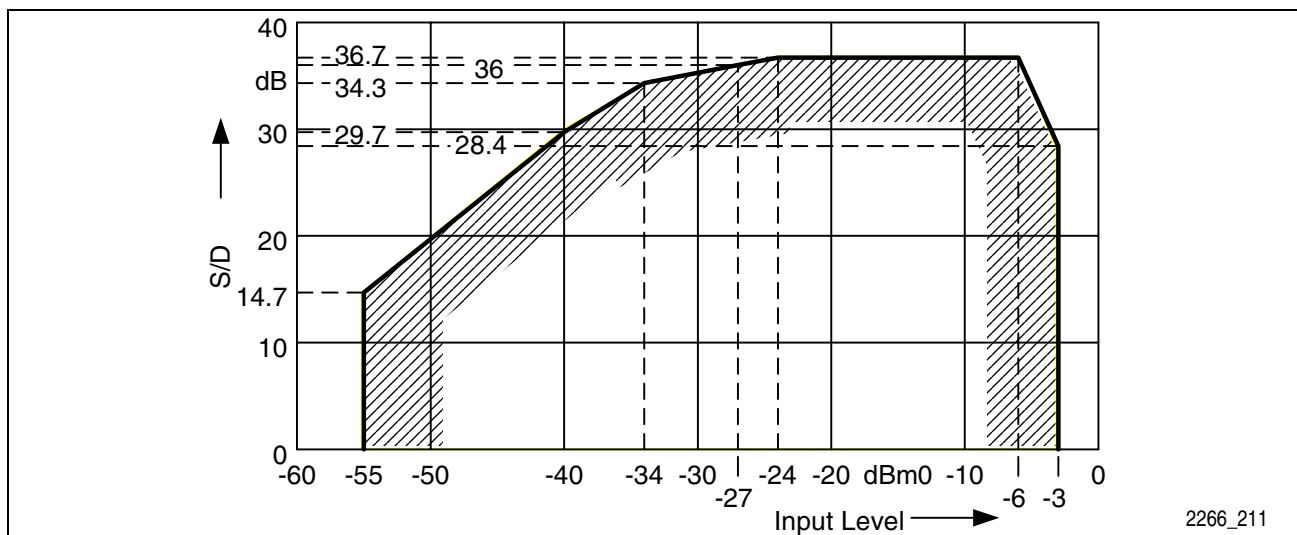

Figure 10 Total Distortion Receive (Noise)

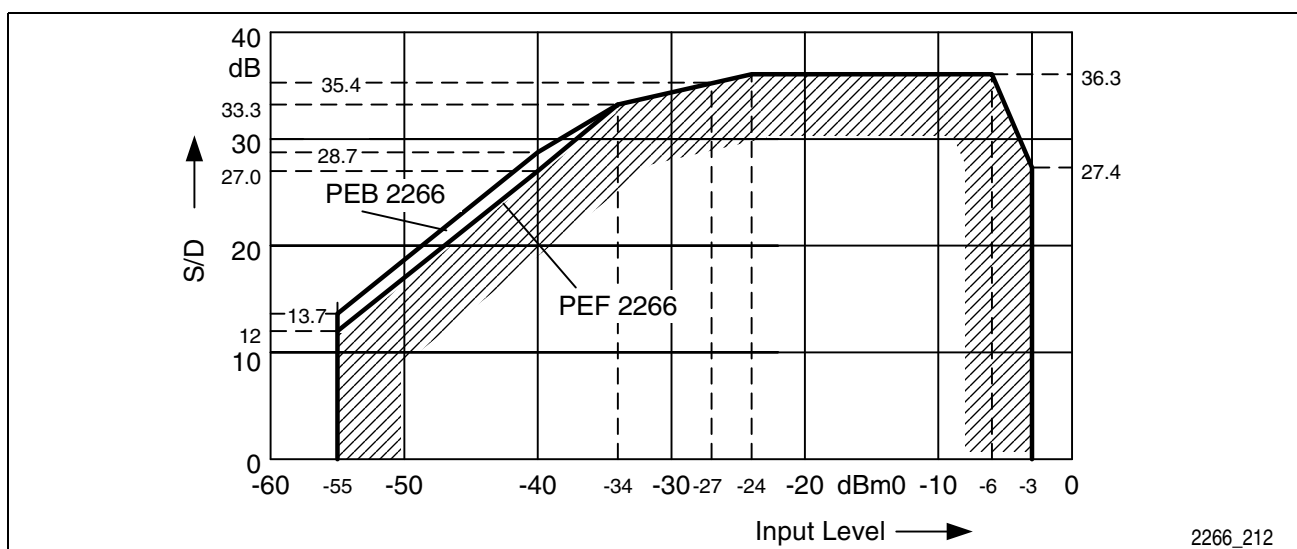

Figure 11 Total Distortion Transmit (Noise)

4.2.12 Single Frequency Distortion

Test Input Signal	Frequency Range	max. Input Level
Receive Direction	300 Hz to 3.4kHz	0 dBm0
Transmit Direction	0 Hz to 12 kHz	0 dBm0

Any resulting signal with a frequency different from the test input signal will stay at least 28 dB below the input signal level.

4.2.13 Overload Compression

This is measured with a 1014 Hz sine-wave signal. The overload point in μ -Law Mode is at 3.17 dBm0.

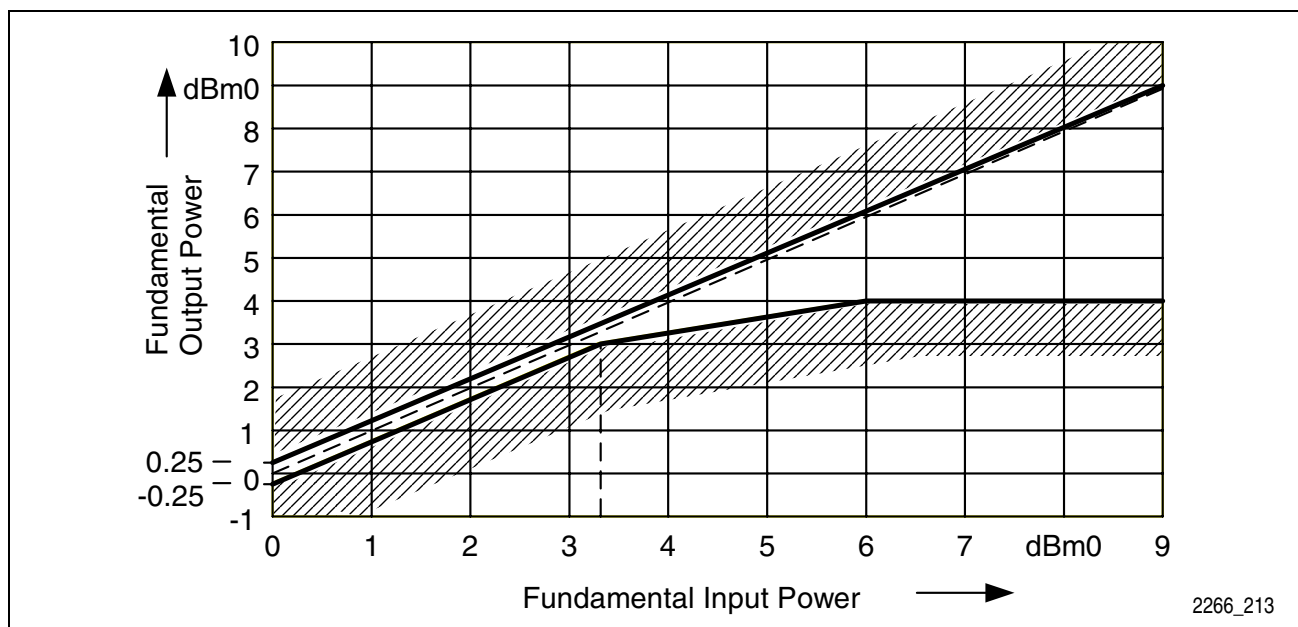

Figure 12 Overload Compression (μ -Law Coding, Transmit Direction)

4.2.14 Crosstalk

Table 17 Crosstalk Between Channels

Parameter	Symbol	Limit Values			Unit	Test Conditions
		min.	typ.	max.		
Crosstalk, 0dBm0	<i>CT</i>		- 85	- 80	dB	$f = 200$ Hz to 3400 Hz, any combination of directions and channels

4.2.15 Out-of-Band Discrimination in Transmit Direction

With any 0 dBm0 sine-wave signal below 100 Hz and in the range from 3.4 kHz to 100 kHz (out-of-band signal) applied to an analog input (V_{INx}), the level of any resulting frequency component at the digital output will stay at least X dB (see **Table 18**) below the output level of a 0 dBm0 1kHz sine-wave reference signal at the analog input.

Table 18 Out-of-Band Signals Applied to the Analog Inputs (V_{INx})

Input Frequency	Min. Output Signal Rejection X	Unit	Test Conditions
0 Hz to 60 Hz	25	dB	0 dBm0 sine-wave input signal on V_{IN}
60 Hz to 100 Hz	10	dB	
3.4 kHz to 4 kHz	$-14 \left(\sin \left(\pi \frac{4000-f}{1200} \right) - 1 \right)$	dB	
4 kHz	15	dB	
4 kHz to 4.6 kHz	$-18 \left(\sin \left(\pi \frac{4000-f}{1200} \right) - \frac{7}{9} \right)$	dB	
4.6 kHz to 100 kHz	40	dB	

The Hardware Filters behind the A/D Converters reject teletax pulses with their poles at 12 kHz \pm 150 Hz and 16 kHz \pm 150 Hz.

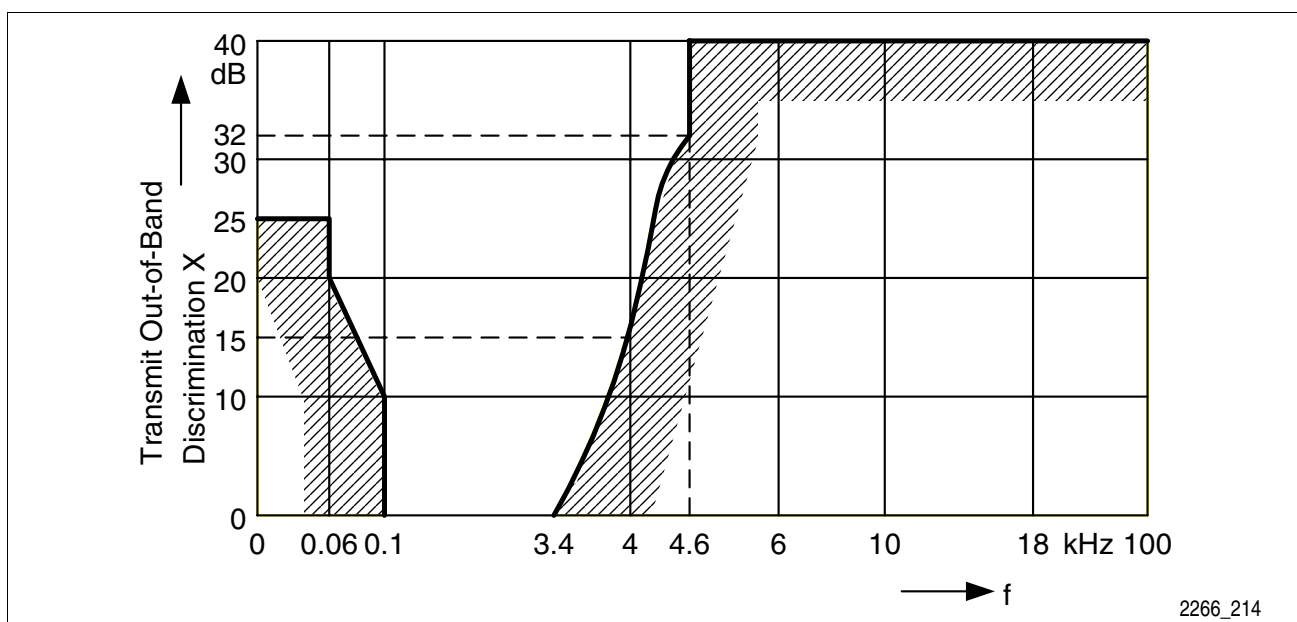

Figure 13 Out-of-Band Discrimination in Transmit Direction

4.2.16 Out-of-Band Discrimination in Receive Direction

With any 0 dBm0 sine-wave frequency in the range from 300 Hz to 3.99 kHz applied to the digital input (PCM time slot), the level of any resulting out-of-band signal at the analog output will stay at least X dB (see **Table 19**) below the output level of a 0 dBm0 1kHz sine-wave reference signal at the digital input.

Table 19 Out-of-Band Signals at the Analog Outputs (V_{OUTx})

Output Frequency	Min. Output Signal Rejection X	Unit	Test Conditions
3.4 kHz to 4.6 kHz	$-14 \left(\sin \left(\pi \frac{4000-f}{1200} \right) - 1 \right)$	dB	0 dBm0 sine-wave input signal on digital input (PCM time slot)
4.6 kHz to 10.55 kHz	$35 + 22 \frac{f-4600}{5950}$	dB	
4 kHz	15	dB	
4.6 kHz	28	dB	
>10.55 kHz	57	dB	

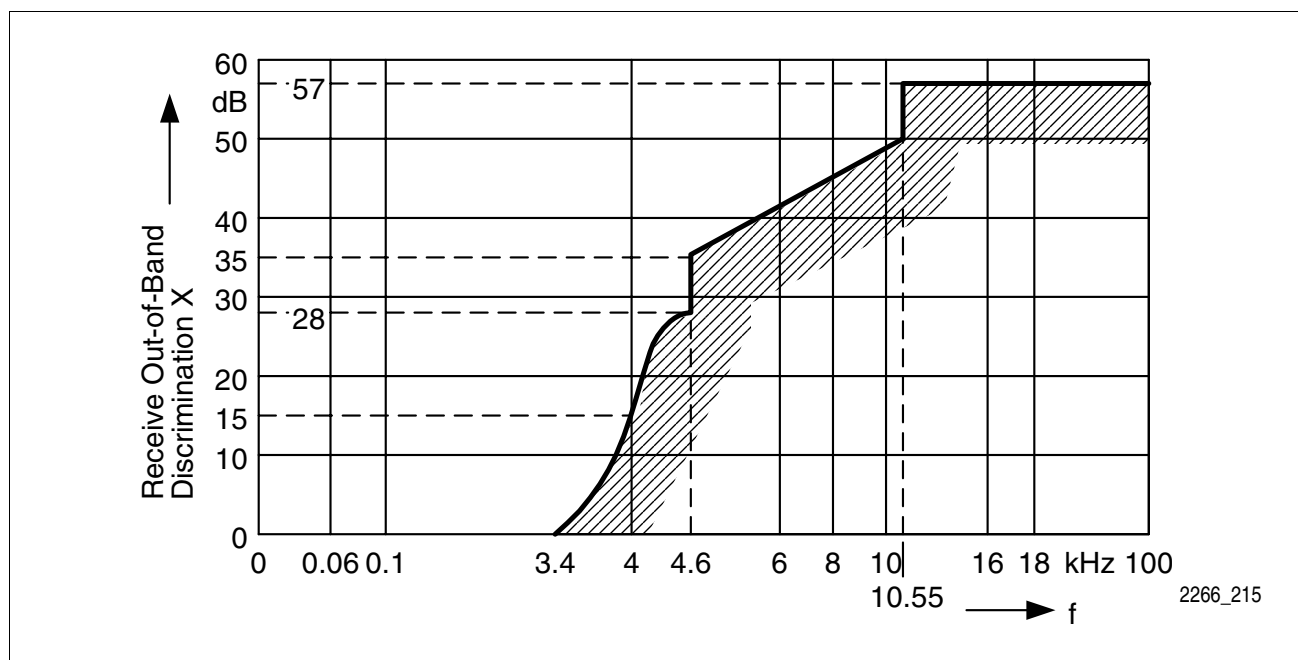

Figure 14 Analog Output: Out-of-Band Signals

4.2.17 Out-of-Band Idle Channel Noise at Analog Output

With an idle code (any sequence of constant PCM octets) applied to the digital input, the level of any resulting out-of-band power spectral density at the analog output, measured with 3 kHz bandwidth, will be not greater than the limit curve shown in **Figure 15**.

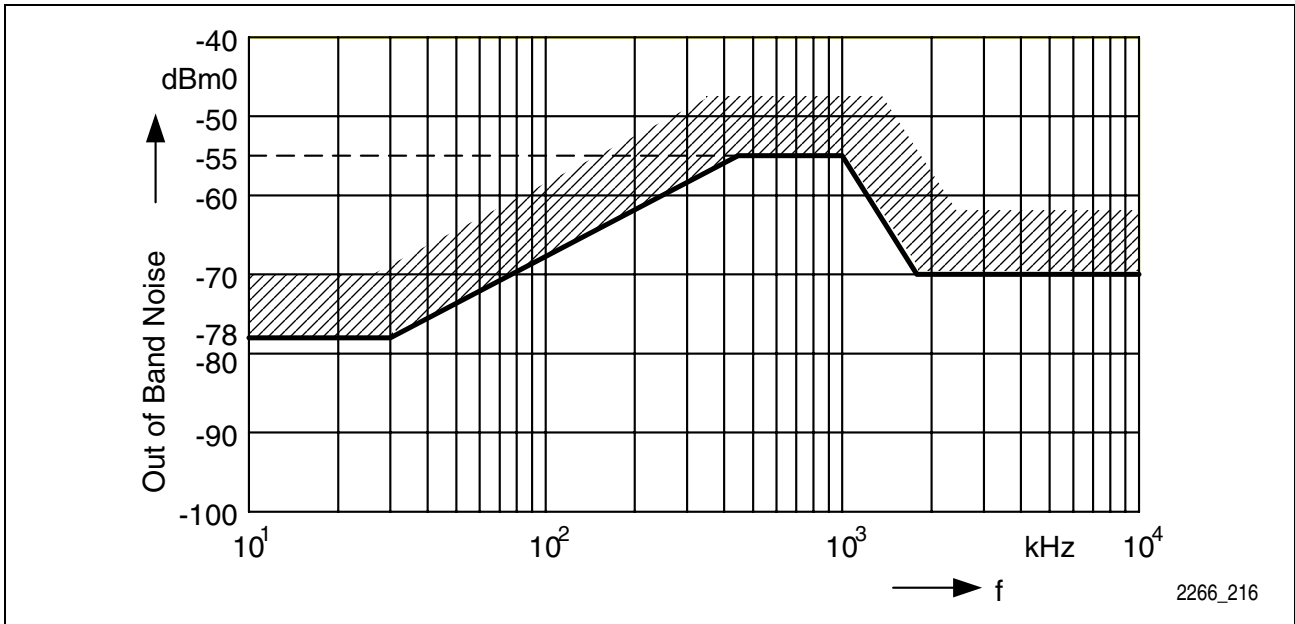

Figure 15 Analog Output: Out-of-Band Idle Channel Noise

4.2.18 Transhybrid Loss

The quality of Transhybrid-Balancing is very sensitive to deviations in gain, group delay, and deviations inherent to the A/D- and D/A-converters, as well as to all external components used on a linecard (SLIC, OP's etc.).

Transhybrid loss test setup:

The SICOFI[®]2- μ C test loop "DLB-ANA" is selected (see **Figure 34**), which connects the analog output with the analog input. The programmable filters FRR, AR, FRX, AX are by-passed. The IM-filter is disabled, ($H(IM)=0$). The balancing filter TH is enabled with optimized coefficients for this configuration ($V_{OUT} = V_{IN}$).

A 0 dBm0 sine wave signal with a frequency in the range of 300 Hz to 3400 Hz is applied to the digital input. The signal levels of the resulting echo at the digital output will stay below the values shown in **Table 20**.

Table 20 Transhybrid Loss

Input Frequency	Symbol	Transhybrid Loss		Unit	Test Condition
		min.	typ.		
300 Hz	THL ₃₀₀	27	40	dB	T _A = 25 °C; V _{DD} = 5 V AGX = AGR = 0 dB; typical variation of amplitude: ± 0.15 dB delay: ± 0.5 μ s.
500 Hz	THL ₅₀₀	30	45	dB	
2500 Hz	THL ₂₅₀₀	29	40	dB	
3000 Hz	THL ₃₀₀₀	27	35	dB	
3400 Hz	THL ₃₄₀₀	27	35	dB	

5 Interface Description

The SICOFI[®]2- μ C provides four interfaces:

- Analog Interface,
- PCM Interface,
- Signaling Interface, and
- Serial Microcontroller Interface.

A general description of these interface is given in the **Product Overview, Chapter 4**. Refer to the **Programmers Reference Manual** for information on the configuration and operation of the four interfaces.

The subsequent chapters in this manual explain how to connect the SICOFI[®]2- μ C to subscriber line interface circuits (SLICs), microcontrollers, and PCM highways.

5.1 Analog Interface

The Analog Interface in combination with a Subscriber Line Interface Circuit (SLIC) forms a configurable tip & ring (t/r) telephone line. The AC transmission characteristic of the SICOFI[®]2- μ C—SLIC combination can be controlled by programming the digital filter structures inside the SICOFI[®]2- μ C. The correct filter coefficients are determined by the targeted AC transmission behavior (e.g. Telco specification) and by the transfer functions of the SLIC.

The SICOFI[®]2- μ C can be interfaced directly to electronic SLICs or transformer solutions. The high driving capability of up to 300 Ohms eliminates the need for an external amplifier that is normally used with transformer SLICs.

The peak amplitude of the analog inputs and outputs is at 2.223 V (overload point).

Out-of-band signals applied to the analog inputs are suppressed by the on-chip digital hardware filters. The poles of these filters are fixed at 12 kHz and 16 kHz which suppresses the echo signal from teletax pulses very efficiently: As long as the amplitude of the teletax echo stays below the overload threshold of 2.223 V_p (1.57 V_{rms}), the voice signal in the transmit path will not be disturbed. Thus, the on-chip hardware filters can eliminate the need for external teletax filters.

5.1.1 Coupling Capacitors at the Analog Interface

A coupling capacitor >39 nF must be used on the V_{IN} -pins in the transmit direction. The required value for the coupling capacitor on the V_{OUT} -pins depends on the input resistance of the SLIC-circuitry (R_{Load}). It has to be chosen to fulfil the frequency response requirement in the receive direction. **Figure 16** can be used to determine an appropriate value for the coupling capacitor (C_{Ext1}).

Interface Description

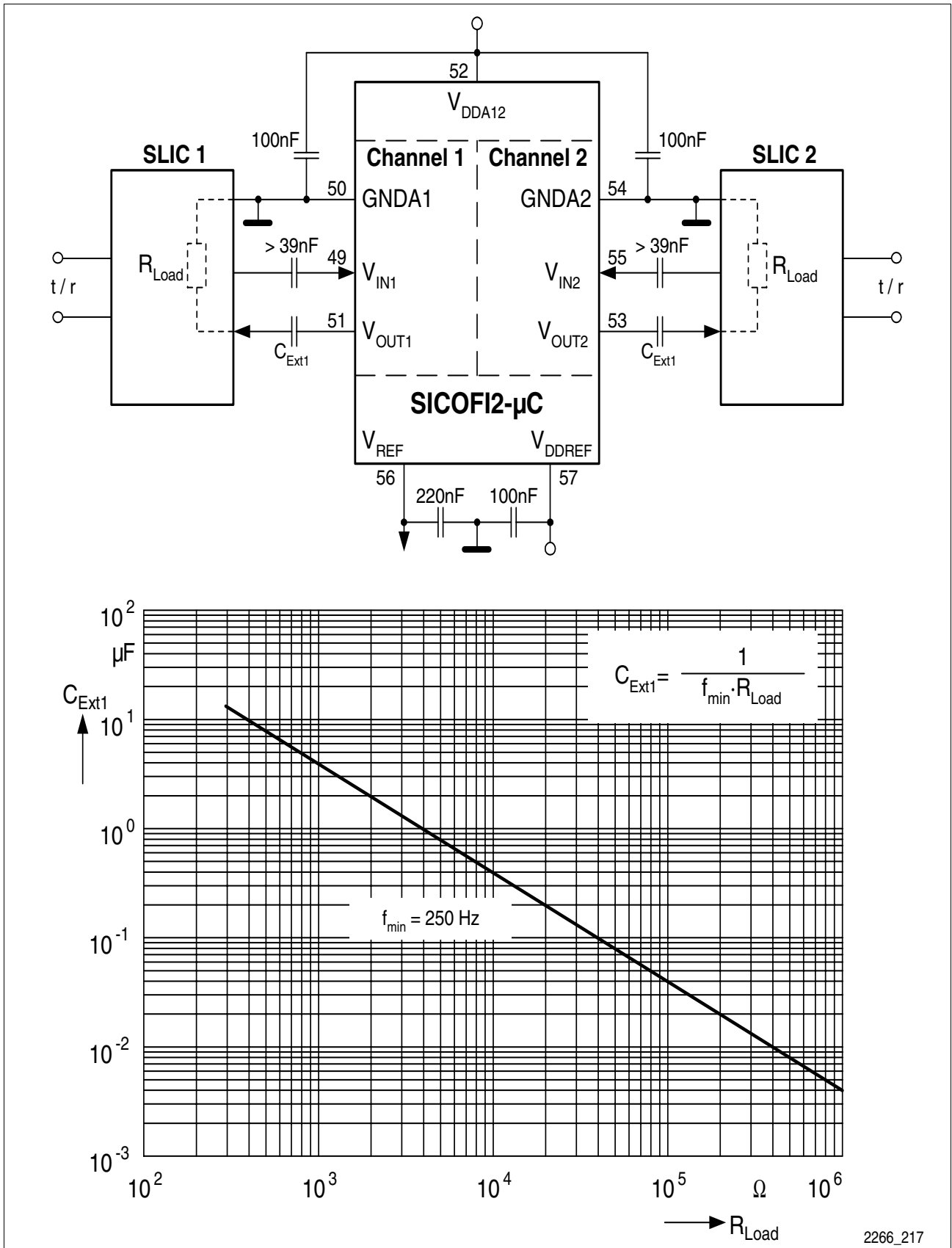

Figure 16 Analog Interface to Two Subscriber Line Interface Circuits (SLICs)

5.1.2 Analog Interface Pins

Table 21 Analog Interface Pins

Channel	Symbol	Pin	Function
	V_{IN1}	49	Analog Input. Requires a coupling capacitor >39 nF to the SLIC (see Figure 16).
	V_{OUT1}	51	Analog Output. Requires a coupling capacitor to the SLIC. The capacitor's value depends on the input impedance of the SLIC, (see Figure 16).
	GNDA1	50	Analog Ground. Internally isolated from GNDD, GNDA, or GNDA2.
	V_{IN2}	55	Analog Input. Requires a coupling capacitor >39 nF to the SLIC (see Figure 16).
	V_{OUT2}	53	Analog Output. Requires a coupling capacitor to the SLIC. The capacitor's value depends on the input impedance of the SLIC, (see Figure 16).
	GNDA2	54	Analog Ground. Internally isolated from GNDD, GNDA, or GNDA2.
	V_{DDA12}	52	Analog Supply Voltage. +5 V (100 nF blocking capacitor required, see Figure 16).
	V_{DDREF}	57	Analog Supply Reference Voltage. +5 V (100 nF blocking capacitor required, see Figure 16).
	V_{REF}	56	Reference Voltage Must connect to a 220 nF cap. to ground, see Figure 16 .

5.2 PCM Interface

The SICOFI[®]2- μ C provides an industry–standard PCM Interface with access to one PCM highways. The PCM Interface has the following features:

- Data rate from 128 kbit/s to 8 Mbit/s per highway,
- 2 to 128 time slots per frame per highway,
- PCM data format serialized 8 bits with MSB first,
- Configurable A-Law or μ -Law coding,
- Independently configurable time slot and highway for each channel and direction,
- PCM clock speed of once or twice the bit rates,
- Programmable sampling slopes, and
- Programmable frame delay.

5.2.1 PCM Interface Pins

Table 22 PCM Interface Pins

Symbol	Pin	Function
PCLK	32	PCM-Clock, 128 kHz to 8192 kHz; shared for both highways.
FSC	31	Frame Synchronization Clock, 8 kHz; shared for both highways.
DRA	27	Receive Data input for PCM-highway A.
DRB	30	Receive Data input for PCM-highway B.
DXA	26	Transmit Data output for PCM-highway A, open drain.
DXB	29	Transmit Data output for PCM-highway B, open drain.
TCA#	25	Transmit Control output for highway A, low when DXA is active.
TCB#	28	Transmit Control output for highway B, low when DXB is active.

5.2.2 PCM Receive and Transmit Example

Figure 17 and **Figure 19** illustrate the time slot and bit positions resulting from the programming example below:

Table 23 PCM Register Configuration Example

Channel	CR4	Receive Setting	CR5	Transmit Setting
1	0000 0000	DRA, time slot 0	0000 0000	DXA, time slot 0
2	0000 1111	DRA, time slot 15	0001 0010	DXA, time slot 18
all	XR6=0000 0000; single clock mode, no PCM offset; PCLK=2048 kHz.			

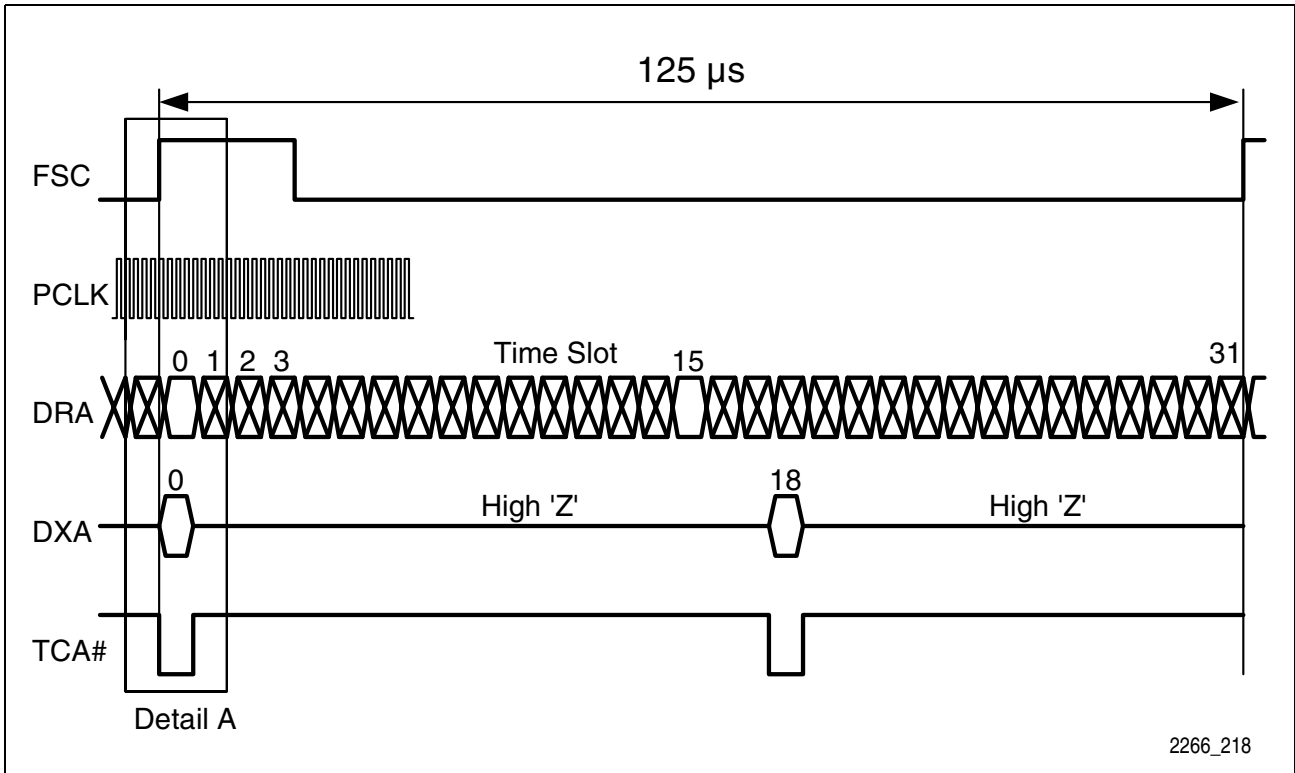

Figure 17 PCM Interface Example: Location of Time Slots

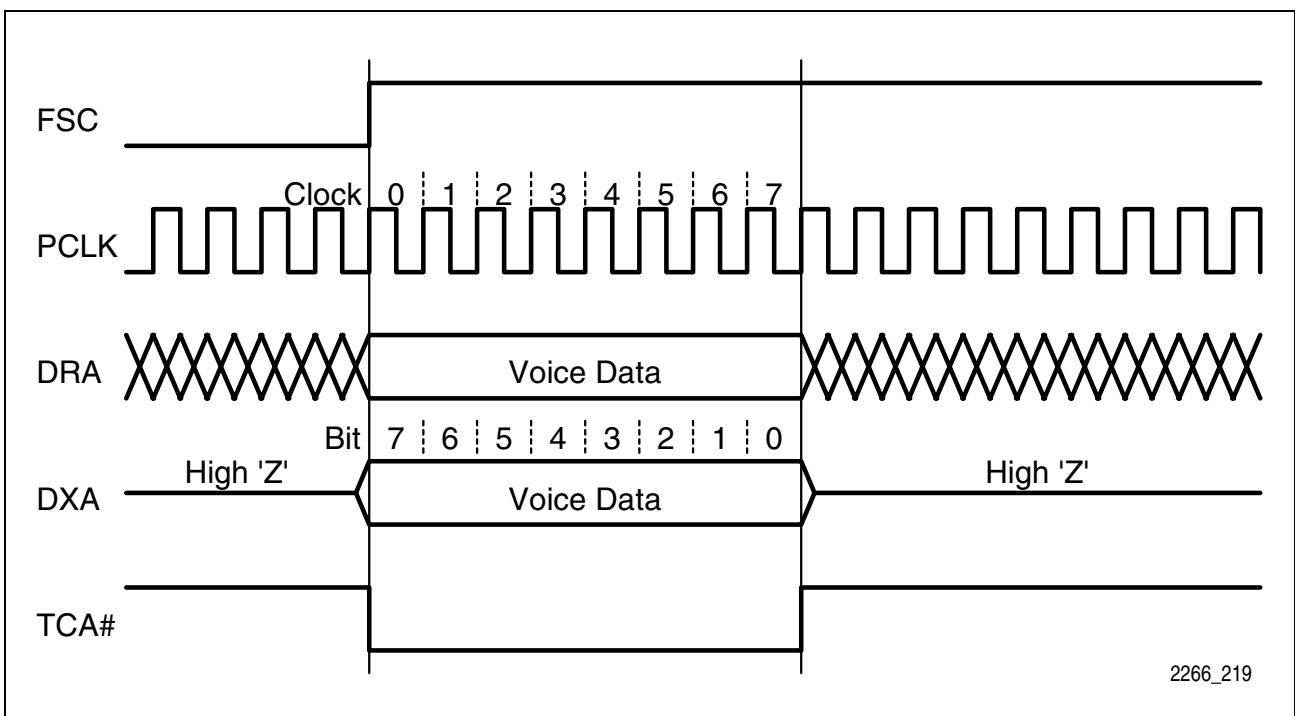

Figure 18 PCM Interface Example: Detail A

The pins DRA/B and DXA/B may be strapped together to form a multiplexed bi-directional PCM port.

5.3 Signaling Interface

The SICOFI[®]2- μ C Signaling Interface is used to monitor and control supervision and signaling functions on up to four subscriber lines. The device generates interrupt signals to indicate signaling status changes on any of the input pins.

The Signaling Interface consists of the following I/O pins and functions:

- 14 signaling pins (2 input pins, 2 output pins, and 3 user-configurable bi-directional pins per channel),
- Debouncing functions,
- 1 interrupts (one for each channel-pair), and
- 2 clock output signals (user configurable).

5.3.1 Signaling Interface Pins

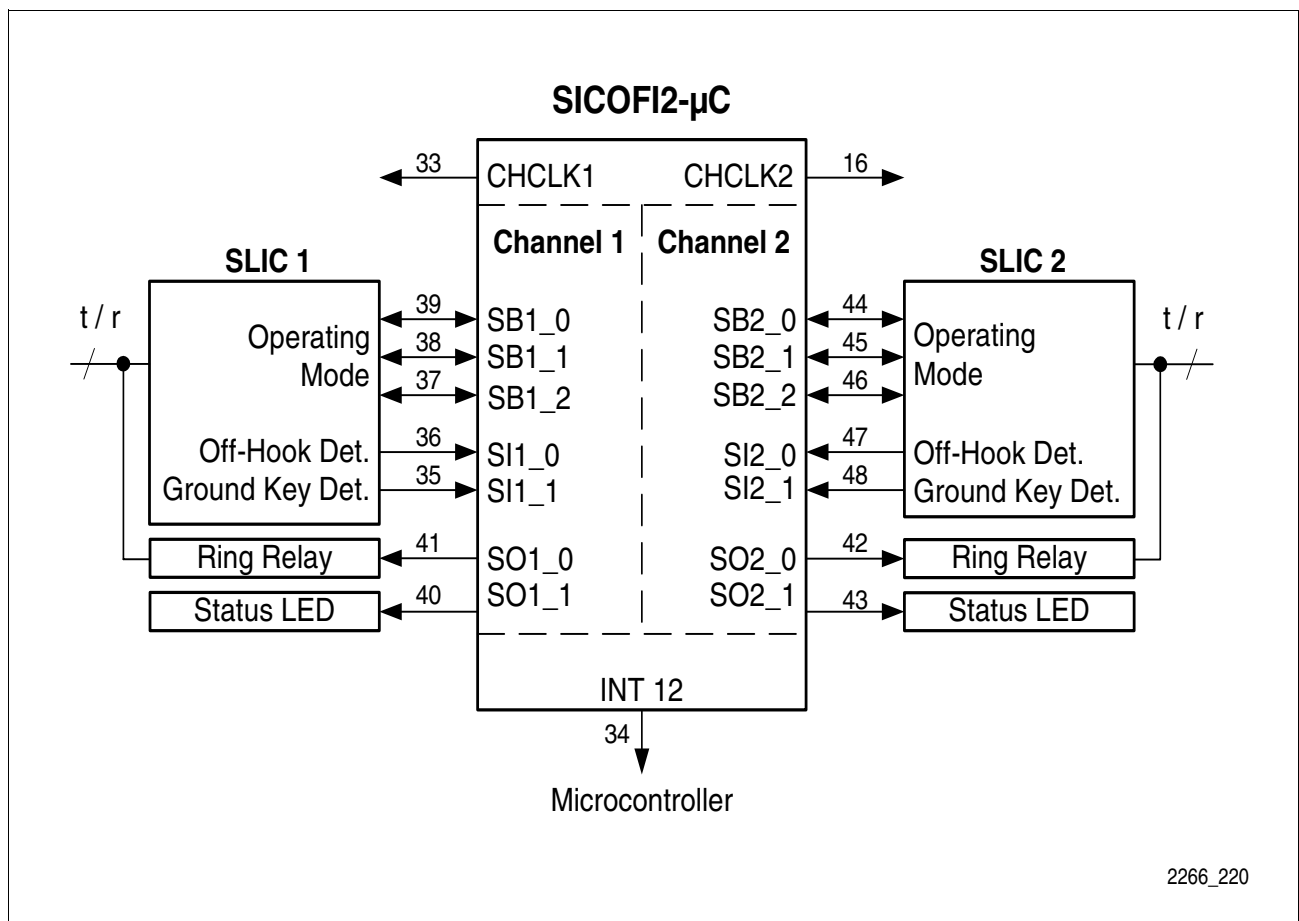

Figure 19 Signaling Example: Two Subscriber Lines

Subscriber Lines

Table 24 Signaling Interface: Pins and Functions for SLIC Interfaces

Channel 1			Channel 2		
Pin	Symbol	Function	Pin	Symbol	Function
36	SI1_0	Signaling Input 0	47	SI2_0	Signaling Input 0
35	SI1_1	Signaling Input 1	48	SI2_1	Signaling Input 1
41	SO1_0	Signaling Output 0	42	SO2_0	Signaling Output 0
40	SO1_1	Signaling Output 1	43	SO2_1	Signaling Output 1
39	SB1_0	Bi-directional Signaling 0	44	SB2_0	Bi-directional Signaling 0
38	SB1_1	Bi-directional Signaling 1	45	SB2_1	Bi-directional Signaling 1
37	SB1_2	Bi-directional Signaling 2	46	SB2_2	Bi-directional Signaling 2
34	INT12	Interrupt Output, Channels 1+2, active high			

5.3.2 Debouncing Functions and Interrupt Generation

All signaling inputs are sampled at programmable intervals (Field N in register XR4). If all the inputs assigned to one channel-pair (1&2) have been stable for two subsequent samples their values are stored in the signaling registers and the associated interrupt output (INT12) is set high. Refer to the *Programmer's Reference Manual* for further details on this function.

5.3.3 Clock Output Signals

Two programmable Chopper Clock Output signals are provided by the PEB 2266:

- CHCLK1 (Pin 33) is configured in register XR4.Field T (bits XR4.3 to XR4.0)
- CHCLK2 (Pin 16) is configured in register XR5.CHCLK2 (bits XR5.3 and XR5.2)
- Both Chopper Clock Output signals are only available if a valid Master Clock signal is applied to pin MCLK.
- CHCLK2 = 16,384 kHz: Requires at least one channel in POWER-UP state.

Table 25 Clock Programming

CHCLK1		CHCLK2	
XR4.Field T	Output (Pin 33)	XR5.CHCLK2	Output (Pin 16)
0000	High level (+5V)	00	High level (+5V)
0001 to 1110	Clock period = T *2ms (min. 2 ms, max. 28 ms)	01	512 kHz signal
		10	256 kHz signal
1111	Low level (0V)	11	16,384 kHz signal

5.4 Serial Microcontroller Interface

The Serial Microcontroller Interface is used to access the SICOFI[®]2- μ C's internal registers and the Coefficient RAM (CRAM). The Serial Microcontroller Interface consists of four pins: two data pins (DIN, DOUT), one clock pin (DCLK) and one pin for chip select (CS#). If DIN and DOUT are strapped together, only three microcontroller I/O pins are required to build this interface.

Figure 20 Serial Microcontroller Interface

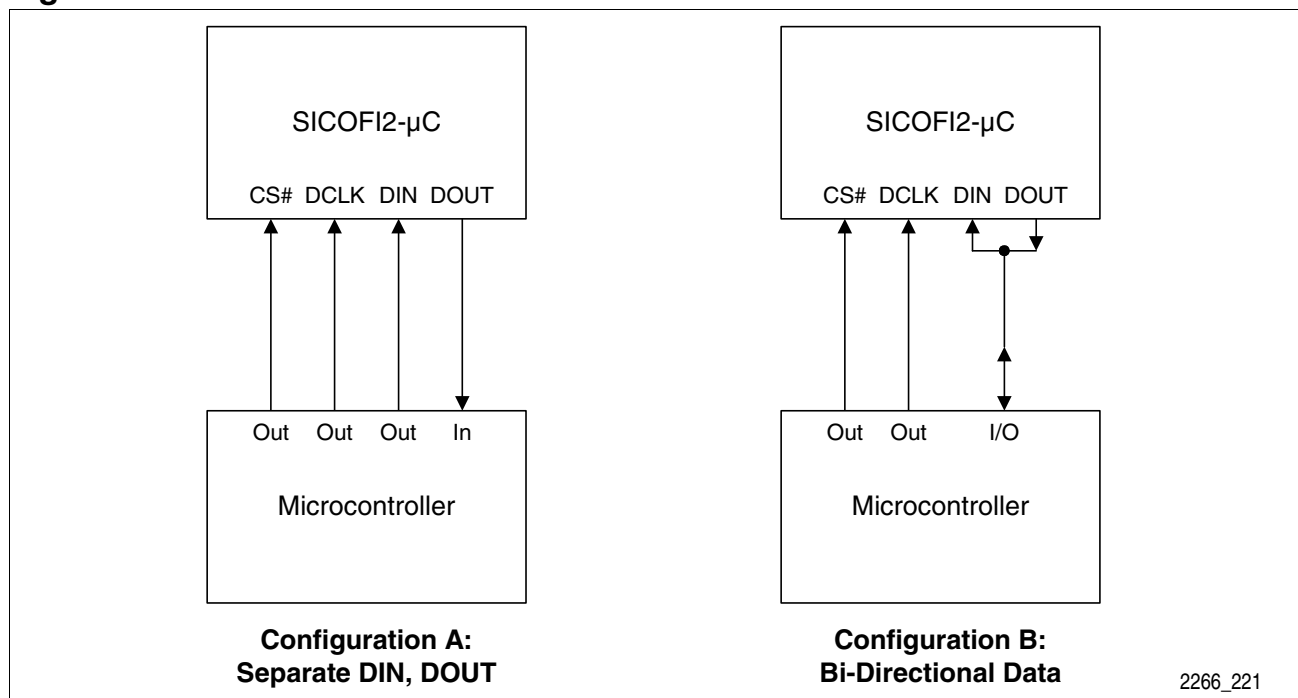

5.4.1 Serial Microcontroller Interface Pins

Table 26 Serial Microcontroller Interface: Pins and Functions

Symbol	Pin	Function
CS#	17	Chip Select, enable to read or write data, active low.
DCLK	18	Data Clock, shifts data from or to device; max. clock rate is 8192 kHz.
DIN	19	Control Data Input; sampled with rising edge of DCLK.
DOUT	20	Control Data Output; bits are shifted with the falling edge of DCLK; DOUT is in high impedance state when no data is transmitted from the SICOFI [®] 2- μ C.

5.4.2 Write Access

Following a falling edge of CS#, the first eight bits received on DIN specify the type of command. The data bytes following a write command are stored in the selected configuration registers or the selected part of the Coefficient RAM. The number of data bytes depends on the type of command. After every command CS# must be set to '1'.

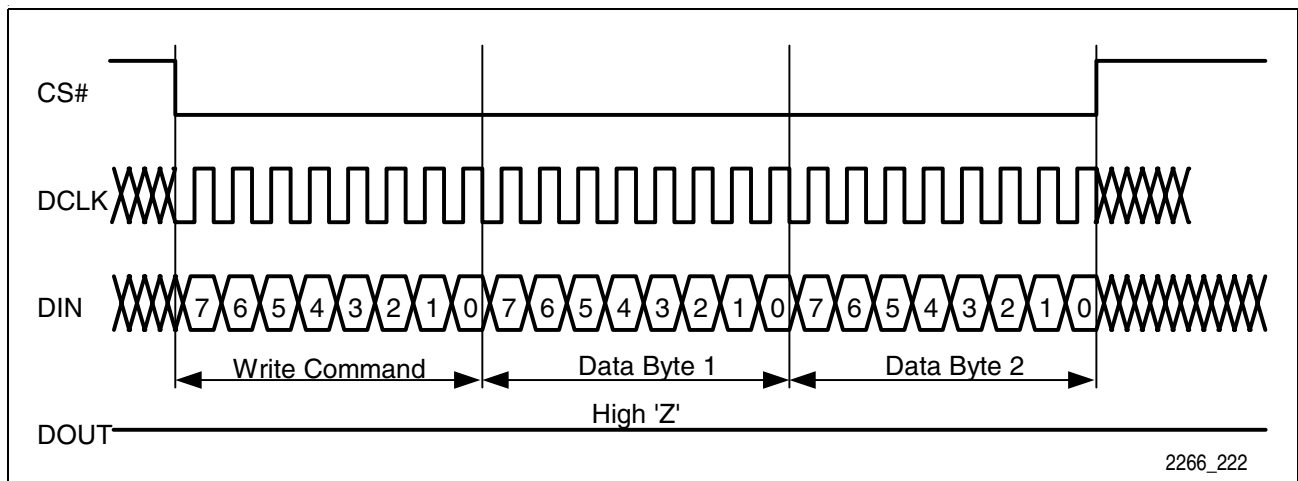

Figure 21 Example for a Two-Byte Write Access

5.4.3 Read Access

If the first eight bits received via DIN represent a read command, the SICOFI[®]2- μ C will initiate its response via DOUT. An identification byte (81_H) is followed by the requested number of data bytes (contents of configuration registers or contents of the CRAM). During execution of a read command, the device will ignore data on DIN. After every command CS# must be set to '1'.

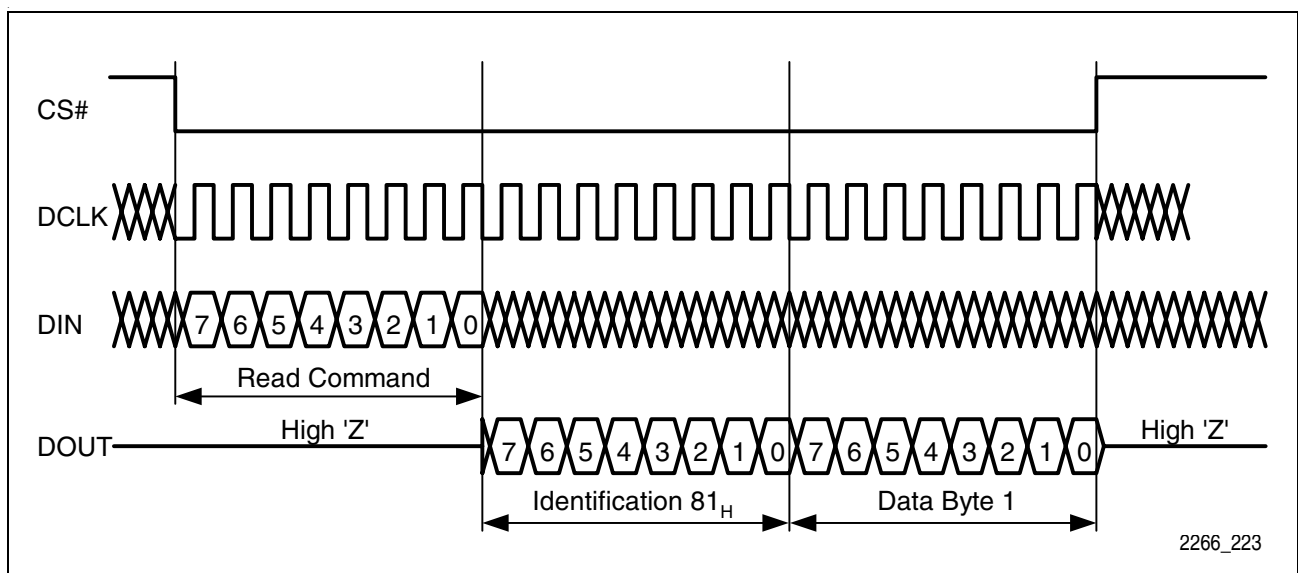

Figure 22 Example for a One-Byte Read Access

Interface Description

For byte-by-byte transfer, the high time of DCLK can be prolonged, resulting in a user-defined 'waiting time' between bytes. This mechanism can be used for writing to and reading from the device.

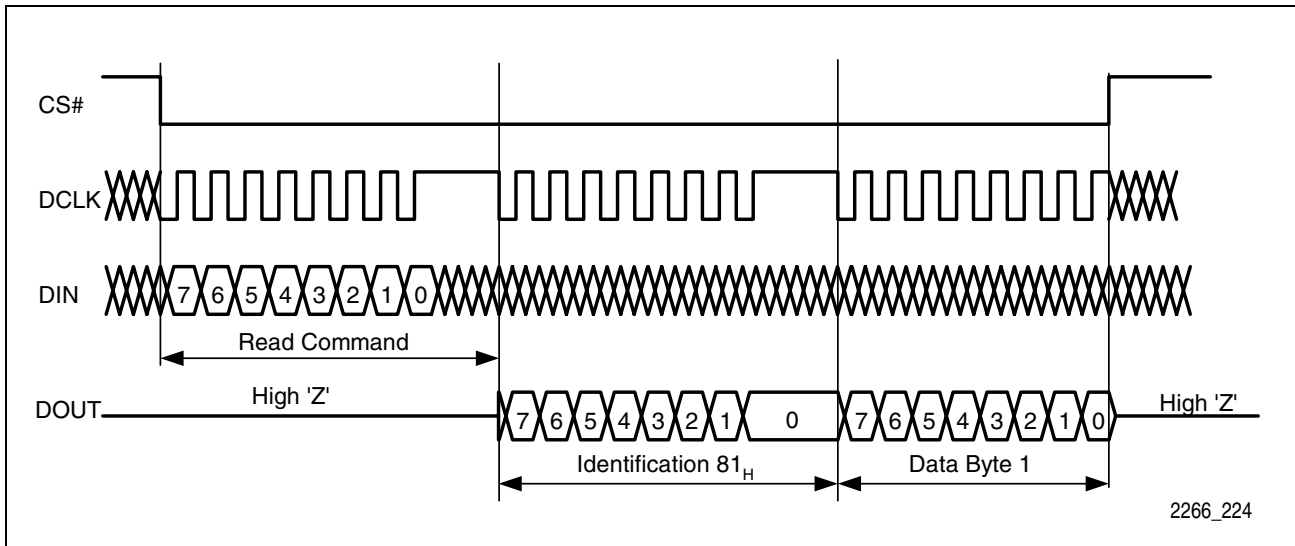

Figure 23 Example for a Read Access with Byte-by-Byte Transfer

Read and write commands can be chained by leaving CS# low after the completion of each command sequence.

For read or write access to individual registers, the command sequence may be terminated by rising CS# after the transmission of any number of bytes.

5.4.4 Three-Wire Access

DIN and DOUT may be strapped together and connected to a single I/O pin of the microcontroller. The interface remains fully functional with only three wire connections. After every command CS# must be set to '1'.

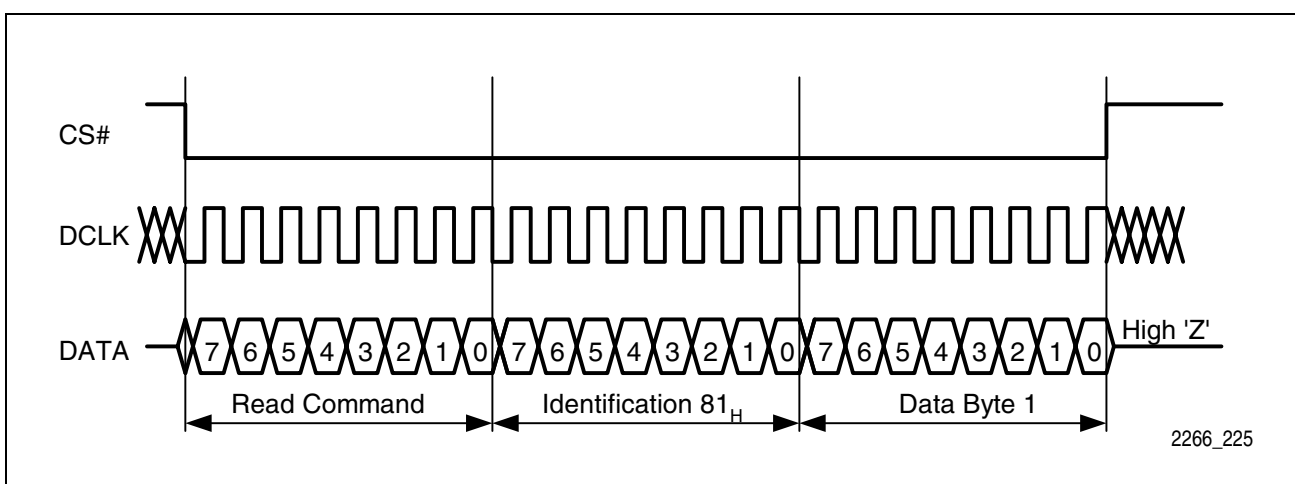

Figure 24 Bi-Directional Data Signal: DIN and DOUT Strapped Together

6 Programming Overview

The transmission characteristics and interfaces of the PEB 2266 can be adapted to various environments. Configuring the functional blocks and programming the digital filter behavior is accomplished by loading values to the Configuration Registers and the Coefficient RAM (CRAM). Software utilities are available to determine the appropriate register and CRAM values (see *Programmer's Reference Manual*).

6.1 Programming Overview

The SICOFI[®]2- μ C has eight Common Configuration Registers (XR0 to XR7). Settings in these registers affect all two channels.

Each of the two channels has six Channel-Specific Configuration Registers (CR0 to CR5). Settings in these registers affect only the designated channel.

The filters of each channel are individually programmable through channel-specific coefficients in CRAM. There are two global sets of TH Filter coefficients that can be assigned to any channel.

6.1.1 Register Model

Channel-specific and Common Configuration Registers and coefficients are shown in **Table 27**.

Table 27 Register Model

Configuration Registers and CRAM	Channel Usage
XR0 to XR7 (8 bytes)	common
CR0 to CR5 (6 bytes)	channel-specific
IM/R1 Coefficients (16 bytes)	
FRR, FRX Coefficients (16 bytes)	
AR1, AR2, AX1, and AX2 Coefficients (8 bytes)	
TG1 and TG2 Coefficients (8 bytes)	
TH Coefficient Set 1 (24 bytes)	one coefficient set per channel
TH Coefficient Set 2 (24 bytes)	

6.1.2 Register Maps

Table 28 Read Access to Common Configuration Register (XR) Map

	Bit 7	Bit 6	Bit 5	Bit 4	Bit 3	Bit 2	Bit 1	Bit 0
XR0	0	0	0	0	SI2_1	SI2_0	SI1_1	SI1_0
XR1	0	0	0	0	SB2_1	SB2_0	SB1_1	SB1_0
XR2	0	0	0	0	PSB2_1	PSB2_0	PSB1_1	PSB1_0
XR3	0	0	SB2_2	SB1_2	0	0	PSB2_2	PSB1_2
XR4	Signal Debounce				CHCLK1			
XR5	MCLK-SEL		CRSH-A	CRSH-B	CHCLK2		Version	
XR6	C-Mode	X-S	R-S	DRV_0	Shift	PCM-OFFSET		
XR7	OF7	OF6	OF5	OF4	OF3	OF2	OF1	OF0

Table 29 Write Access to Common Configuration Register (XR) Map

	Bit 7	Bit 6	Bit 5	Bit 4	Bit 3	Bit 2	Bit 1	Bit 0
XR0	0	0	0	0	SO2_1	SO2_0	SO1_1	SO1_0
XR1	0	0	0	0	SB2_1	SB2_0	SB1_1	SB1_0
XR2	0	0	0	0	PSB2_1	PSB2_0	PSB1_1	PSB1_0
XR3	0	0	SB2_2	SB1_2	0	0	PSB2_2	PSB1_2
XR4	Signal Debounce				CHCLK1			
XR5	MCLK-SEL		CRSH-A	CRSH-B	CHCLK2		Version	
XR6	C-Mode	X-S	R-S	DRV_0	Shift	PCM-OFFSET		
XR7	OF7	OF6	OF5	OF4	OF3	OF2	OF1	OF0

Table 30 Channel-Specific Configuration Register (CR) Map (Read & Write)

	Bit 7	Bit 6	Bit 5	Bit 4	Bit 3	Bit 2	Bit 1	Bit 0
CR0	TH	IM/R1	FRX	FRR	AX	AR	TH-SEL	
CR1	ETG2	ETG1	PTG2	PTG1	LAW	0	0	PU
CR2	COT/R			0	IDR	LM	LMR	V+T
CR3	TEST-Loops				AGX	AGR	D-HPX	D-HPR
CR4	R-way	RS6	RS5	RS4	RS3	RS2	RS1	RS0
CR5	X-way	XS6	XS5	XS4	XS3	XS2	XS1	XS0

6.1.3 CRAM Structure

Coefficient RAM (CRAM) is used to store the individual coefficients calculated for each channel. The coefficients can be written and read through the Microcontroller Interface. The IM, FRX, FRR, AX, AR, TG1, TG2, and TH coefficients are accessed through the Coefficient Operation (COP) Command Sequences which include the channel address (see *Programmer's Reference Manual Chapter 6.5*).

Channel-specific coefficients always belong to their designated channel. Common coefficients (TH) can be assigned to any of the two channels through field TH-SEL in CR0 (see **Figure 25**).

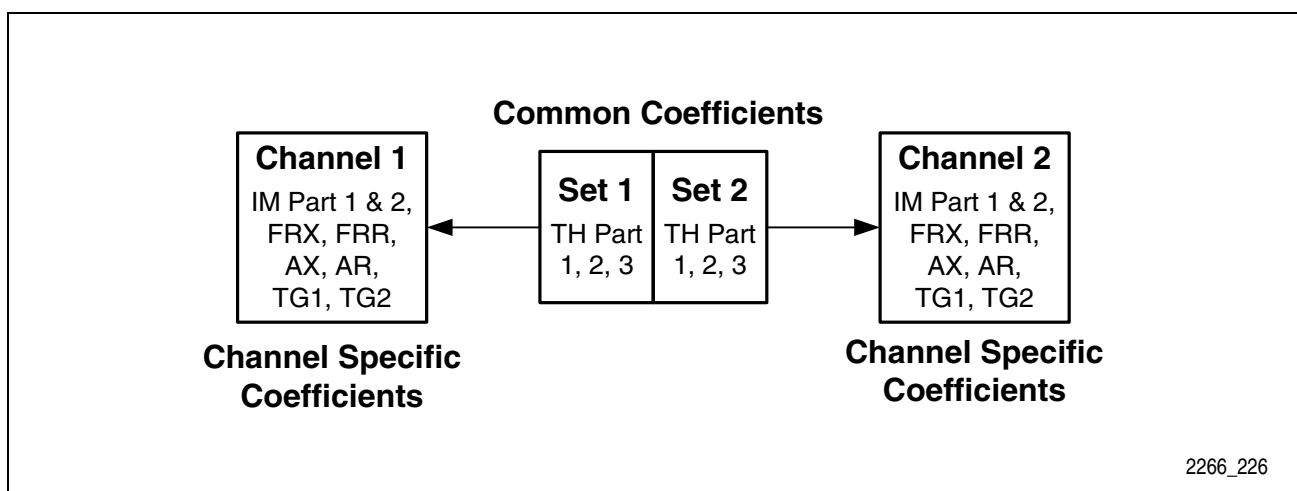

Figure 25 Channel-Specific and Common Coefficients

Table 31 Coefficient RAM (CRAM) Structure per Channel

IM Part 1	8 Coefficient Bytes
IM Part 2	8 Coefficient Bytes
FRX	8 Coefficient Bytes
FRR	8 Coefficient Bytes
AX	4 Coefficient Bytes
AR	4 Coefficient Bytes
TG1	4 Coefficient Bytes
TG2	4 Coefficient Bytes

Table 32 Coefficient RAM (CRAM) Structure per Set

TH Part 1	8 Coefficient Bytes
TH Part 2	8 Coefficient Bytes
TH Part 3	8 Coefficient Bytes

6.2 Types of Commands and Data Bytes

Coefficients and register contents are programmed and accessed through command sequences via the Microcontroller Interface. There are three types of command sequences:

- **Extended Operation (XOP)** for access to the Common Configuration Registers (XR0 to XR7) including the Control Registers for the signaling interface.
- **Status Operation (SOP)** for access to the Channel-Specific Registers (CR0 to CR5), e.g. enabling and disabling of filters, time slot assignment, and test loops.
- **Coefficient Operation (COP)** for access to the CRAM structures. Coefficients can be written to the SICOFI[®]2- μ C, and also read back.

Table 33 Types of Commands and Data Bytes.

	7	6	5	4	3	2	1	0
XOP	RST	0	RW	1	1	LSEL		
SOP	AD		RW	1	0	LSEL		
COP	AD		RW	0	CODE			

With the first byte received via DIN, a command type is selected through bits 3 and 4. A two-bit address field (AD) in the COP and SOP commands allows access to the channel-specific structures (CRAM and CR registers). Since the XR Registers are common for all channels, no address field is required within the XOP command byte.

All three commands allow read and write access, which is indicated by bit 5 (RW). The bit fields LSEL and CODE specify the type and the length of data that follows the command.

7 Application Hints

7.1 Support Tools

7.1.1 Development Board

The Evaluation Package EASY 2466 includes the following hardware:

- One SICOFI[®]2- μ C Evaluation Board STUT 2466 with connectors for four optional SLIC daughter cards and BNC connectors to a PCM backplane.
- One microcontroller board EVC50x with RS-232 interface that translates data from a PC to SICOFI[®]2- μ C format.
- Two SLIC Babyboards STUT 5502 with HARRIS SLIC HC 5502 mounted.

The QSICOS software enables the calculation of the coefficients and the download of the setup file to the evaluation board.

This setup allows measurements and optimization of the actual behavior of a complete transmission system. The EASY 2466 evaluation system connects directly to industry-standard test equipment.

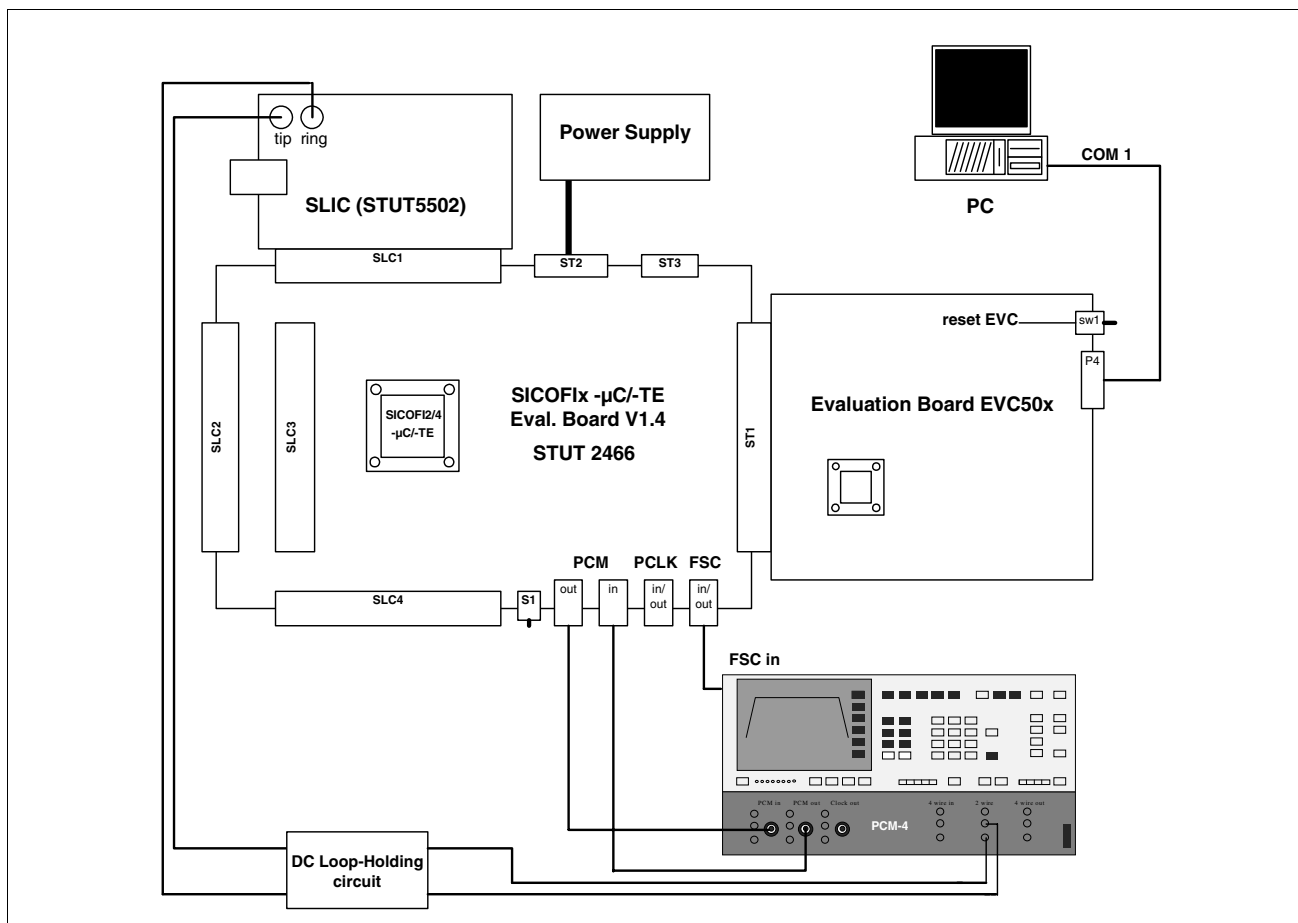

Figure 26 Development System with STUT 2466 Evaluation Board

7.2 Guidelines for Board Design

7.2.1 Filter Capacitors

- For high frequency noise rejection, use 100 nF SMD ceramic capacitors on pins V_{DDA12} , V_{DDA} and V_{DDREF} and connect to GNDA. Additional 2.2 μ F tantalum capacitors are recommended.
- Use one 100 nF SMD ceramic capacitor on pin V_{DDD} and connect to GNDD.
- Use a 1 μ F – 10 μ F tantalum capacitor from +5 V supply to GND (central blocking).

Note: All blocking capacitors MUST be placed as close as possible to the SICOFI[®]2- μ C pins.

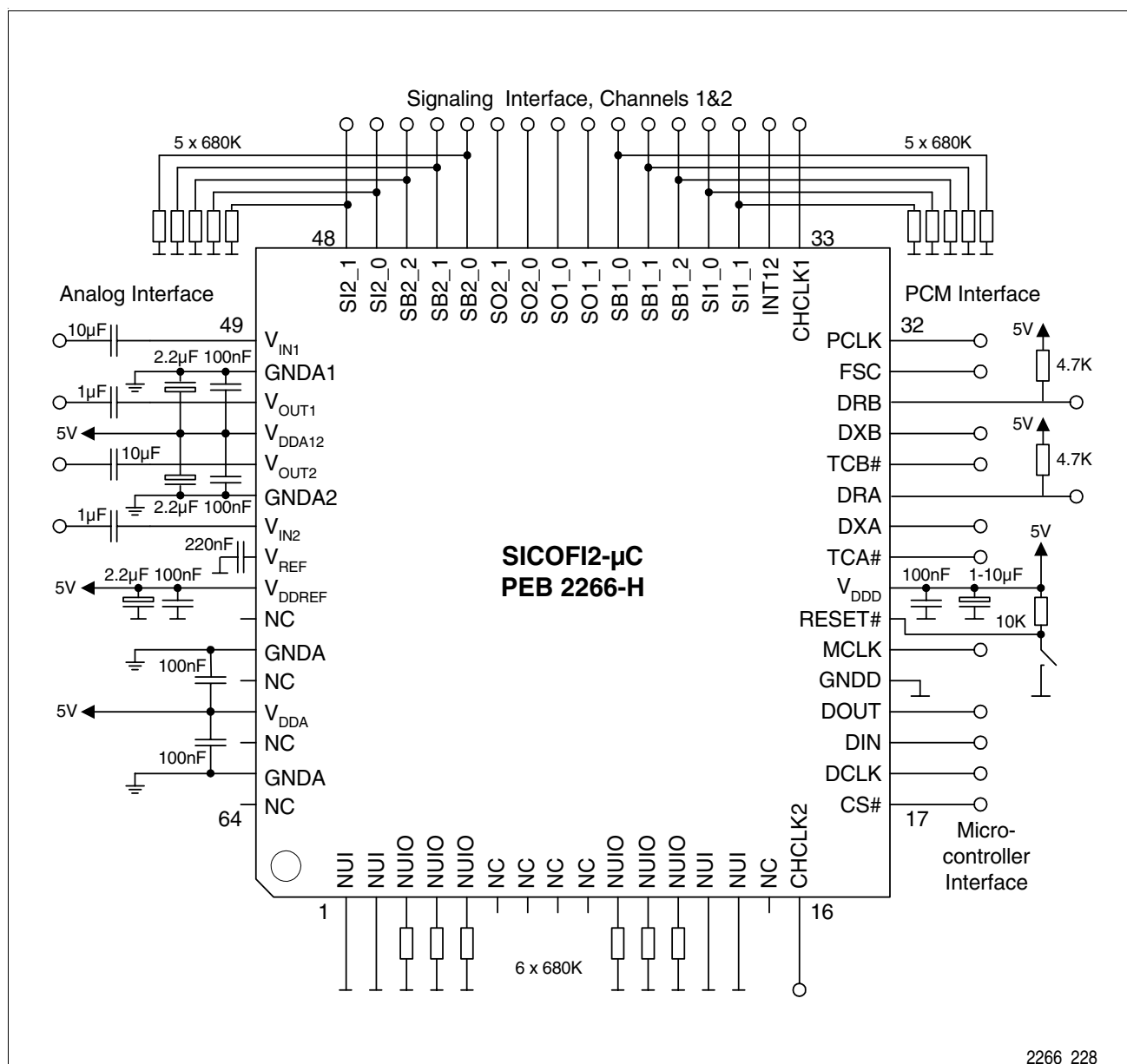

Figure 27 SICOFI[®]2- μ C Test Circuit Configuration

7.3 Proposal for SICOFI[®]2- μ C Board Design

For a new layout design it is recommended to use a separate ground-layer which gives the possibility to connect all ground-pins of the SICOFI[®]2- μ C (GNDA and GNDD) low-ohmic together.

Furthermore, an optimum board layout should follow these recommendations

- Separate all digital supply lines from analog supply lines as far as possible
- Applying the standard practice regarding blocking capacitors is recommended
- Place all SLIC circuits as close as possible to the Vinx/Voutx pins of the SICOFI
- Separate all analog circuitry (especially SLIC and Vinx/Voutx) as far as possible from any digital signal source (esp. clock signals)

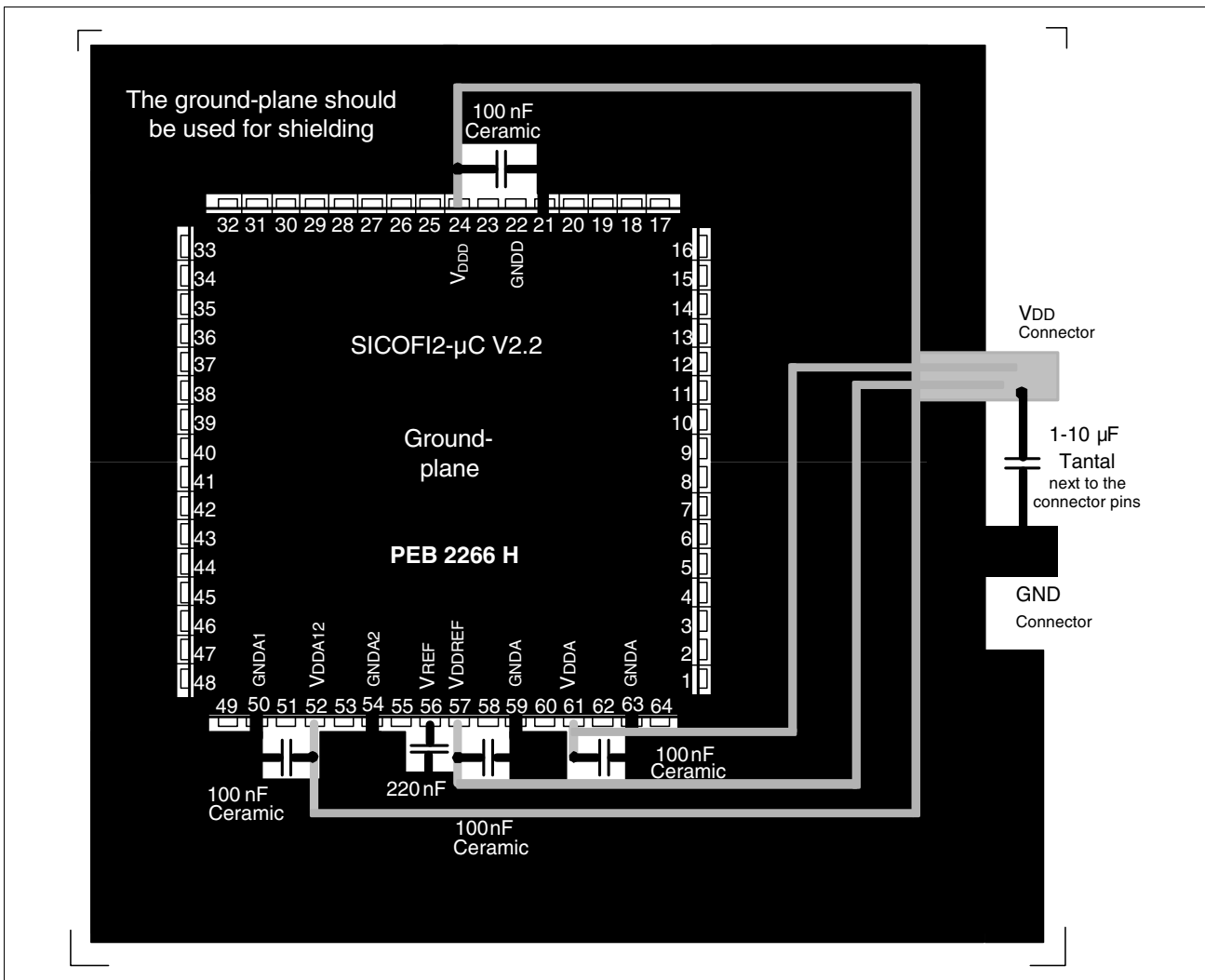

Figure 28 Proposal for a Ground Concept

VDD is the grey colored layer and the Ground-plane is the black colored layer. The Ground-plane should be on both sides of the board on the top and on the ground layer.

8 Electrical Characteristics and Timing Diagrams

8.1 Absolute Maximum Ratings

Parameter	Symbol	Limit Values		Unit	Test Condition
		min.	max.		
V_{DD} referred to GNDD		-0.3	7.0	V	
GNDA to GNDD		-0.6	0.6	V	
Analog input and output voltage Referred to $V_{DD} = 5\text{ V}$; Referred to GNDA = 0 V		-5.3 -0.3	0.3 5.3	V V	
All digital input voltages Referred to GNDD = 0 V; ($V_{DD} = 5\text{ V}$) Referred to $V_{DD} = 5\text{ V}$; (GNDD = 0 V)		-0.3 -5.3	5.3 0.3	V V	
DC input and output current at any input or output pin (free from latch-up)			10	mA	
Storage temperature	T_{STG}	-60	125	°C	
Ambient temperature under bias	T_A	-10	80	°C	
Power dissipation (package)	P_D		1	W	

Note: Stresses above those listed here may cause permanent damage to the device. Exposure to absolute maximum rating conditions for extended periods may affect device reliability.

Electrical Characteristics and Timing Diagrams

8.2 Operating Range

$V_{DD} = 5\text{ V} \pm 5\%$; $GNDD = 0\text{ V}$; $GNDA = 0\text{ V}$;
 $T_A = 0\text{ }^\circ\text{C}$ to $+70\text{ }^\circ\text{C}$ (PEF 2266: $-40\text{ }^\circ\text{C}$ to $+85\text{ }^\circ\text{C}$)

Parameter	Symbol	Limit Values			Unit	Test Condition
		min.	typ.	max.		
V_{DD} supply current:	I_{DD}					FSC = 8 kHz, PCLK = MCLK = 2.048 MHz, no loads, PCM idle codes,
Standby (PEB 2266)			0.5	1.0	mA	
Standby (PEF 2266)			0.5	1.5	mA	
1 channel operating			14	25	mA	
2 channels operating		18	30	mA		
Power supply rejection ratio (either direction)	$PSRR$	30			dB	Ripple: sine wave 1014 Hz, 70 mVrms, on every supply pin, AGX=AGR=AX=AR=0dB (see Chapter 4.2.4)

8.3 Digital Interface

$V_{DD} = 5\text{ V} \pm 5\%$; $GNDD = 0\text{ V}$; $GNDA = 0\text{ V}$;
 $T_A = 0\text{ }^\circ\text{C}$ to $+70\text{ }^\circ\text{C}$ (PEF 2266: $-40\text{ }^\circ\text{C}$ to $+85\text{ }^\circ\text{C}$);

Parameter	Symbol	Limit Values		Unit	Test Condition
		min.	max.		
Input voltages:					
Low level	V_{IL}	-0.3	0.8	V	
High level	V_{IH}	2.0		V	
Output voltages:					
Low level	V_{OL}		0.45	V	$I_{OL} = -2\text{ mA}$
Low level	V_{OL}		0.8	V	$I_{OL} = -5\text{ mA}$
High level	V_{OH}	4.4		V	$I_{OH} = 0.4\text{ mA}$
High level	V_{OH}	4.0		V	$I_{OH} = 2\text{ mA}$
High level	V_{OH}	2.4		V	$I_{OH} = 5\text{ mA}$
Input leakage current	V_{IL}		± 1	μA	$-0.3 \leq V_{IN} \leq V_{DD}$

Electrical Characteristics and Timing Diagrams

8.4 Analog Interface

$V_{DD} = 5\text{ V} \pm 5\%$; $GNDD = 0\text{ V}$; $GNDA = 0\text{ V}$;
 $T_A = 0\text{ }^\circ\text{C}$ to $+70\text{ }^\circ\text{C}$ (PEF 2266: $-40\text{ }^\circ\text{C}$ to $+85\text{ }^\circ\text{C}$)

Parameter	Symbol	Limit Values			Unit	Test Condition
		min.	typ.	max.		
Input resistance	R_i					
PEF 2266		160	270	500	$k\Omega$	$0 \leq V_{IN} \leq V_{DD}$
PEB 2266		160	270	380	$k\Omega$	
Output resistance	R_o			0.25	Ω	
Output load	R_L C_L	300		50	Ω pF	
Input leakage current	I_{IL}		± 0.1	± 1.0	μA	$0 \leq V_{IN} \leq V_{DD}$
Input offset voltage	V_{IO}			± 50	mV	
Output offset voltage	V_{OO}			± 50	mV	
Input voltage range (AC)	V_{IN}			± 2.223	V	

8.4.1 Coupling Capacitors at the Analog Interface

Coupling capacitors are required on pins V_{IN} and V_{OUT} .

The recommended value for V_{IN} is $>39\text{ nF}$. The required value for the V_{OUT} capacitor depends on the input impedance of the SLIC (see **Figure 16** in **Chapter 5.1**).

8.5 Reset Timing

To reset the SICOFl[®]2- μC to Reset State, logic low pulses applied to pin RESET# must be below 1.2 V (TTL-Schmitt-Trigger Input) and must persist longer than 3 μs .

Note: Spikes shorter than 1 μs will be ignored.

Electrical Characteristics and Timing Diagrams

8.6 PCM-Interface Timing

8.6.1 Single Clocking Mode

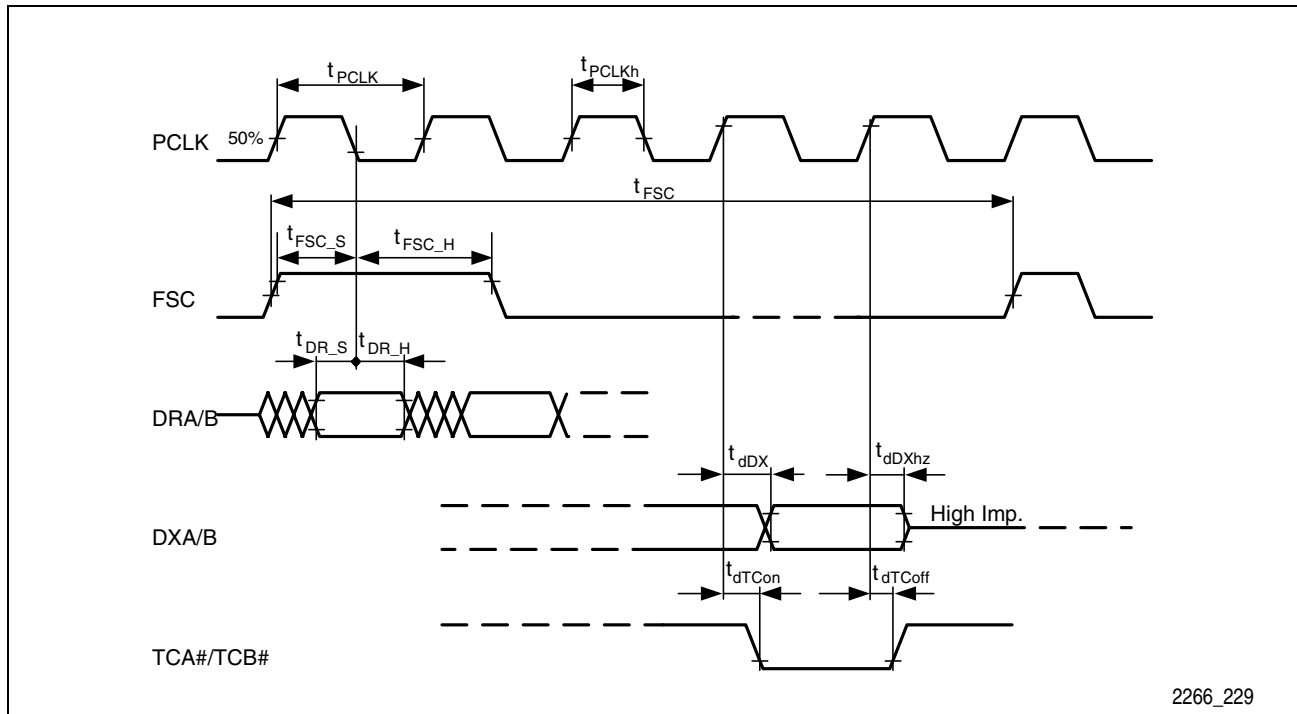

2266_229

Figure 29 PCM Interface Timing in Single Clocking Mode

Parameter	Symbol	Limit Values			Unit
		min.	typ.	max.	
Period of PCLK	t_{PCLK}	1/8192		1/128	ms
PCLK high time	t_{PCLKh}	$0.4 \cdot t_{PCLK}$	$t_{PCLK}/2$	$0.6 \cdot t_{PCLK}$	μ s
Period FSC	t_{FSC}		125		μ s
FSC setup time	t_{FSC_s}	10	50		ns
FSC hold time	t_{FSC_h}	40	50		ns
DRA/B setup time	t_{DR_s}	10	50		ns
DRA/B hold time	t_{DR_h}	10	50		ns
DXA/B delay time ¹⁾	t_{dDX}	25		$t_{dDX_{min}} + t_{C_{Load}}$	ns
DXA/B delay time to high Z	t_{dDXhz}	25		50	ns
TCA#/TCB# delay time on	t_{dTCon}	25		$t_{dTCon_{min}} + t_{C_{Load}}$	ns
TCA#/TCB# delay time off	t_{dTCoFF}	25		$t_{dTCoFF_{min}} + t_{C \cdot R}$	ns

¹⁾ Min. delay times: intrinsic time, caused by internal processing. Max. delay times: min. time + delay caused by external components C_{Load} and R_{Pullup} :
 $t_{C_{Load}} = 0.4ns \cdot C_{Load}/pF$,
 $t_{C \cdot R} = R_{Pullup} \cdot C_{Load}$; $R_{Pullup} > 1.5k\Omega$

8.6.2 Double Clocking Mode

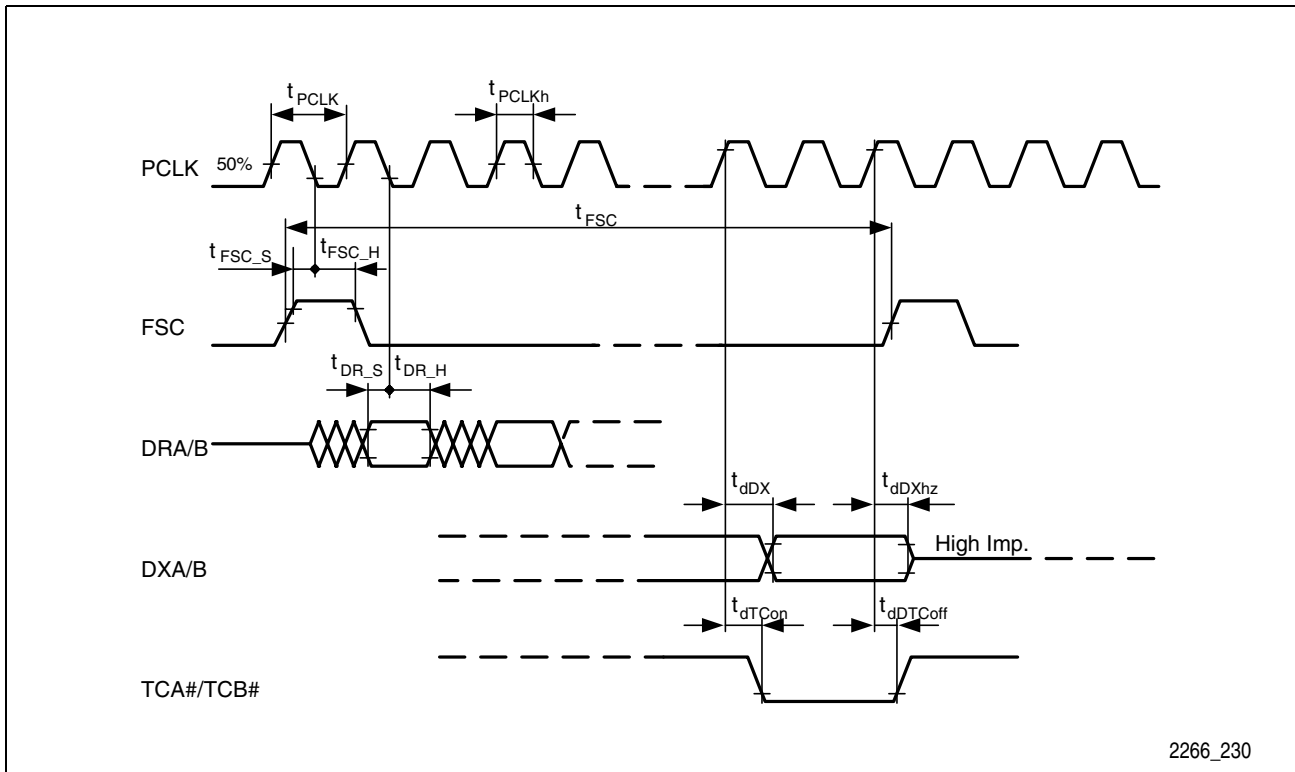

2266_230

Figure 30 PCM Interface Timing in Double Clocking Mode

Parameter	Symbol	Limit Values			Unit
		min.	typ.	max.	
Period of PCLK	t_{PCLK}	1/8192		1/256	ms
PCLK high time	t_{PCLKh}	$0.4 \cdot t_{PCLK}$	$t_{PCLK}/2$	$0.6 \cdot t_{PCLK}$	μ s
Period FSC	t_{FSC}		125		μ s
FSC setup time	t_{FSC_s}	10	50		ns
FSC hold time	t_{FSC_h}	40	50		ns
DRA/B setup time	t_{DR_s}	10	50		ns
DRA/B hold time	t_{DR_h}	10	50		ns
DXA/B delay time ¹⁾	t_{dDX}	25		$t_{dDX_{min}} + t_{C_{Load}}$	ns
DXA/B delay time to high Z	t_{dDXhz}	25		50	ns
TCA#/TCB# delay time on	t_{dTCon}	25		$t_{dTCon_{min}} + t_{C_{Load}}$	ns
TCA#/TCB# delay time off	t_{dTCoFF}	25		$t_{dTCoFF_{min}} + t_{C^*R}$	ns

¹⁾ Min. delay times: intrinsic time, caused by internal processing. Max. delay times: min. time + delay caused by external components C_{Load} and R_{Pullup} .:

$$t_{C_{Load}} = 0.4ns \cdot C_{Load}/pF,$$

$$t_{C^*R} = R_{Pullup} \cdot C_{Load}; R_{Pullup} > 1.5k\Omega$$

8.7 Microcontroller Interface Timing

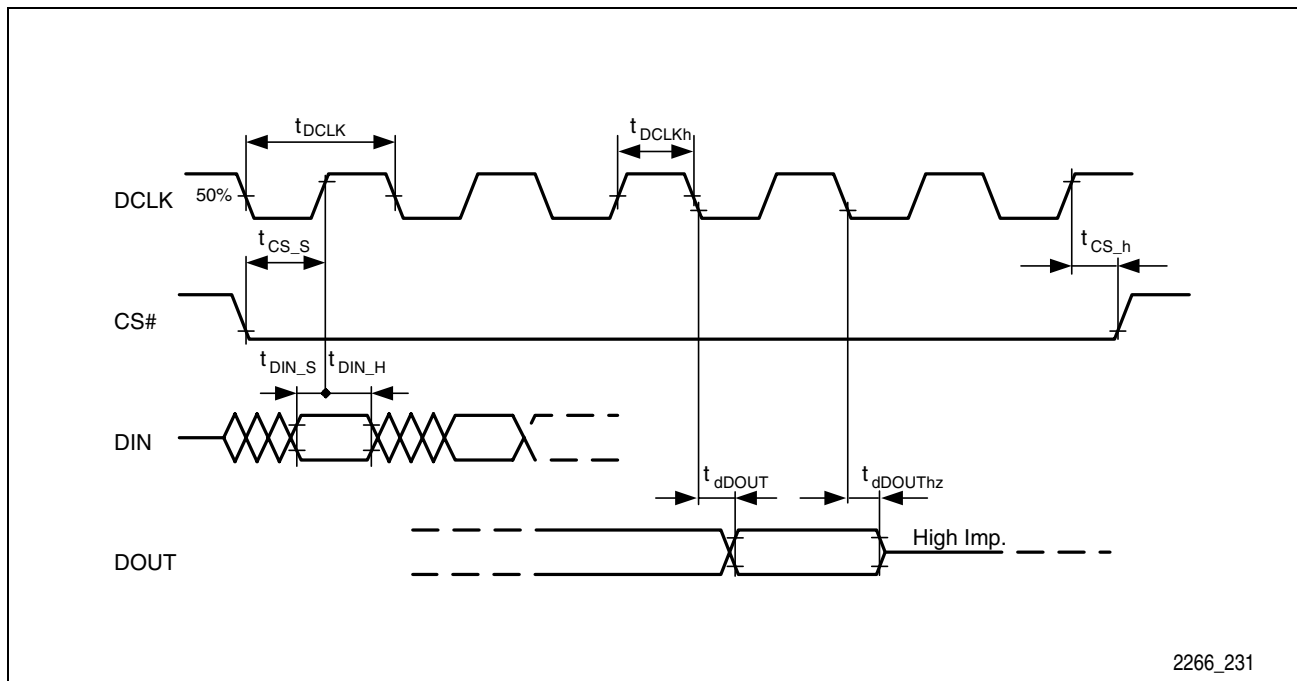

2266_231

Figure 31 Timing of the Microcontroller Interface

Parameter	Symbol	Limit Values			Unit
		min.	typ.	max.	
Period of DCLK	t_{DCLK}	1/8192			ms
DCLK high time	t_{DCLKh}	$0.4 \cdot t_{DCLK}$	$t_{DCLK}/2$	$0.6 \cdot t_{DCLK}$	μ s
CS# setup time	t_{CS_s}	10	50		ns
CS# hold time	t_{CS_h}	30	50		ns
DIN setup time	t_{DIN_s}	10	50		ns
DIN hold time	t_{DIN_h}	10	50		ns
DOUT delay time ¹⁾	t_{dDOUT}	30		$t_{dDOUT_min} + t_{C_Load}$	ns
DOUT delay time to high Z	$t_{dDOUThz}$	30		50	ns

¹⁾ All delay times are made up by two components: an intrinsic time (min-time), caused by internal processing, and a second component $t_{C_Load} = 0.4ns \cdot C_{Load}/pF$, caused by external circuitry (C-load).

8.8 Signaling Interface Timing

8.8.1 Timing from the μ C Interface to the SO/SB-pins

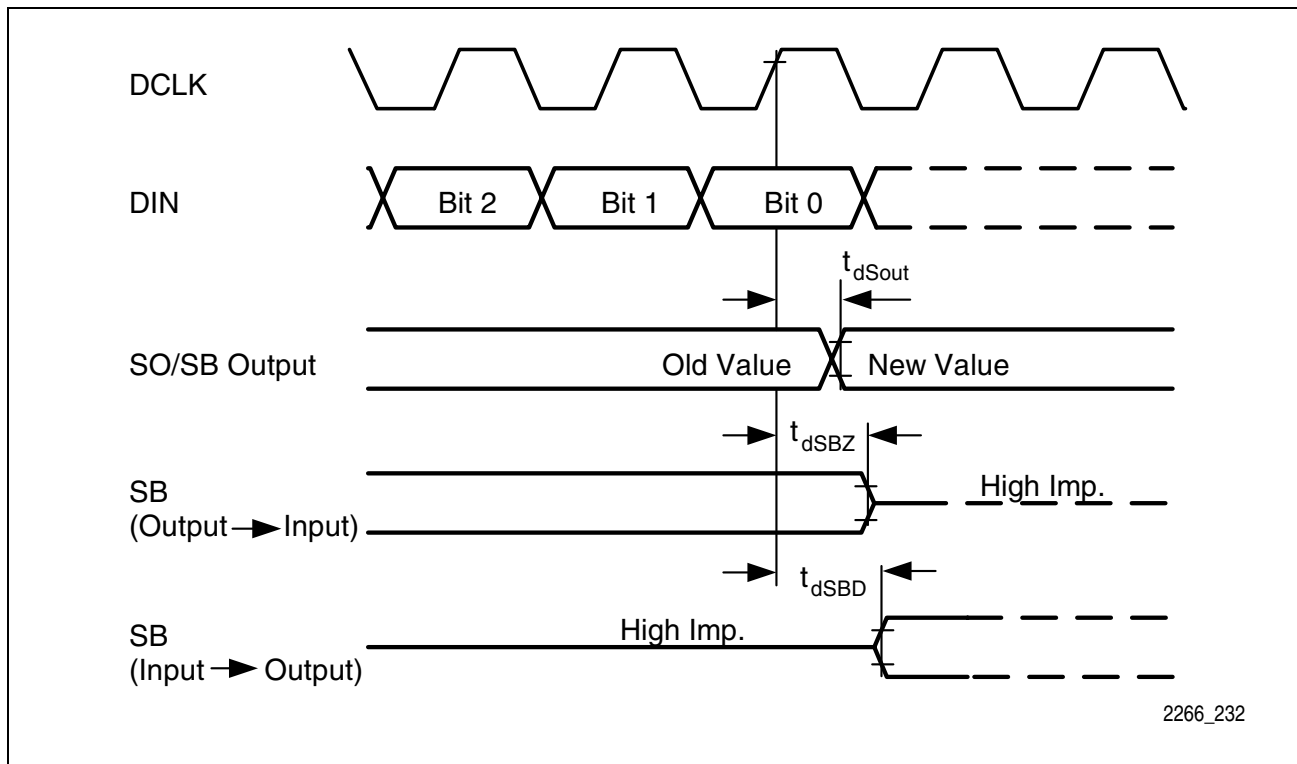

Figure 32 Signaling Output Timing (data downstream)

Parameter	Symbol	Limit Values			Unit
		min.	typ.	max.	
SO/SB delay time ¹⁾	t_{dSout}	30		$t_{dSout_min} + t_{C_Load}$	ns
SB to 'Z' - time	t_{dSBZ}	40		100	ns
SB to 'drive'-time	t_{dSBD}	40		$t_{dSBD_min} + t_{C_Load}$	ns

¹⁾ All delay times are made up by two components: an intrinsic time (min-time), caused by internal processing, and a second component $t_{C_Load} = 0.4ns * C_{Load} / pF$, caused by external circuitry (C-load).

8.8.2 Timing from the SI/SB-pins to the μ C Interface

The register update and interrupt behavior resulting from signaling input changes (data upstream – pins SI and SB, if programmed as signaling inputs) depend on internal sampling clocks, counters and register settings. See **Chapter 5.3.2** for a functional description.

9 Test Modes

Each SICOFI[®]2- μ C channel has four test loops that feed the analog input signal back to the analog output (analog test loops), and five test loops that feed the PCM input signal back to the PCM output.

Note: The signal path can also be cut off at two different points per receive and transmit direction.

9.1 Analog Loops

The four analog loops feed signals from the transmit path back into the receive path. **Figure 33** shows the locations of the analog loops.

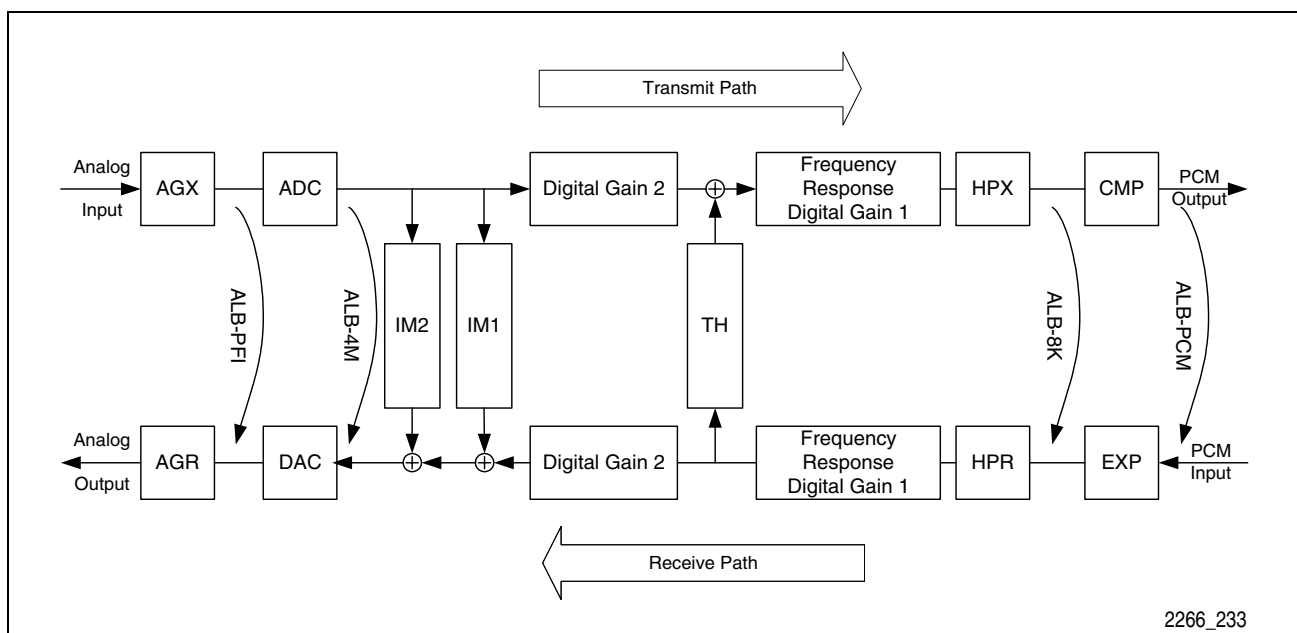

Figure 33 Analog Loops

Table 34 Analog Loop Programming in Register CR3, Bits 7 to 4

Test-Loops	Analog Loops (CR3.7 = 0)
0000	All loops are disabled (normal operation).
0001	ALB-PFI Analog Loop Back via PREFI-POFI is selected.
0011	ALB-4M Analog Loop Back via 4 MHz is selected.
0100	ALB-PCM Analog Loop Back via 8 kHz (PCM) is selected and in all channels active . (required slope setting in XR6.6, XR6.5 = 00 or 11).
0101	ALB-8K Analog Loop Back via 8 kHz (linear) is selected.

9.2 Digital Loops

The digital loops feed signals from the receive path back to the transmit path. There are five digital loops, which are shown in **Figure 34**.

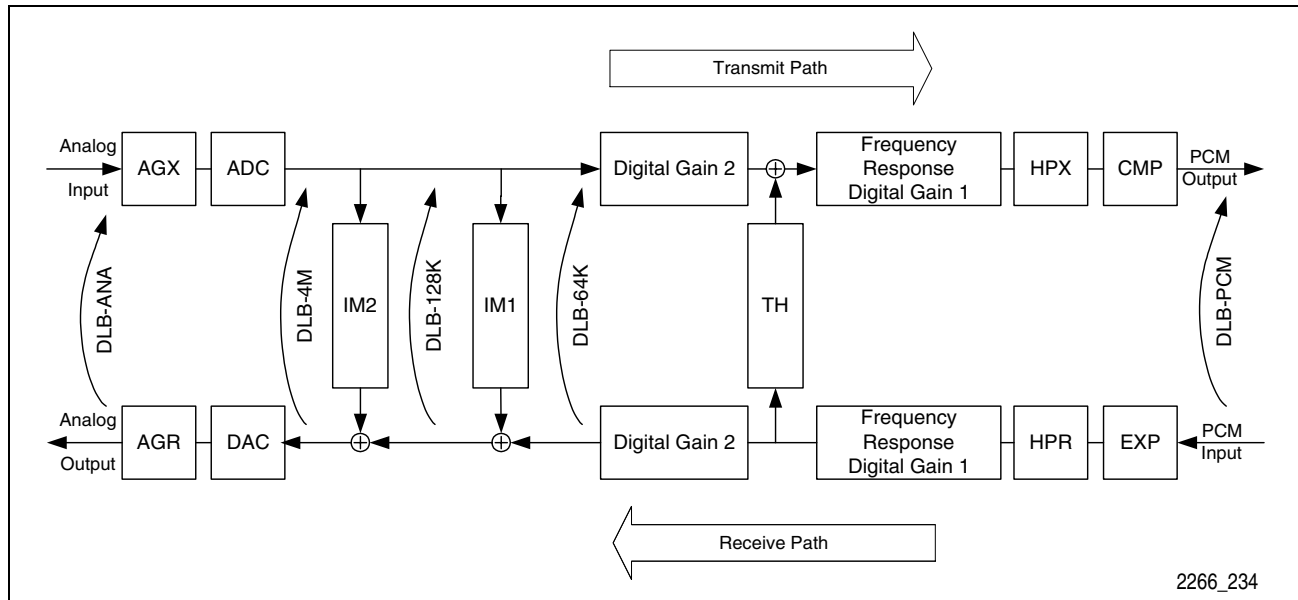

Figure 34 Digital Loops

Table 35 Digital Loop Programming in Register CR3, Bits 7 to 4

Test-Loops	Digital Loops (CR3.7 = 1)
1000	DLB-ANA Digital Loop Back via analog port is selected.
1001	DLB-4M Digital Loop Back via 4 MHz is selected.
1100	DLB-128K Digital Loop Back via 128 kHz is selected.
1101	DLB-64K Digital Loop Back via 64 kHz is selected.
1111	DLB-PCM Digital Loop Back via PCM Registers is selected.

9.3 Cut-Off's

The transmit path and the receive path can be cut off at two locations each. **Figure 35** shows the locations in the signal paths.

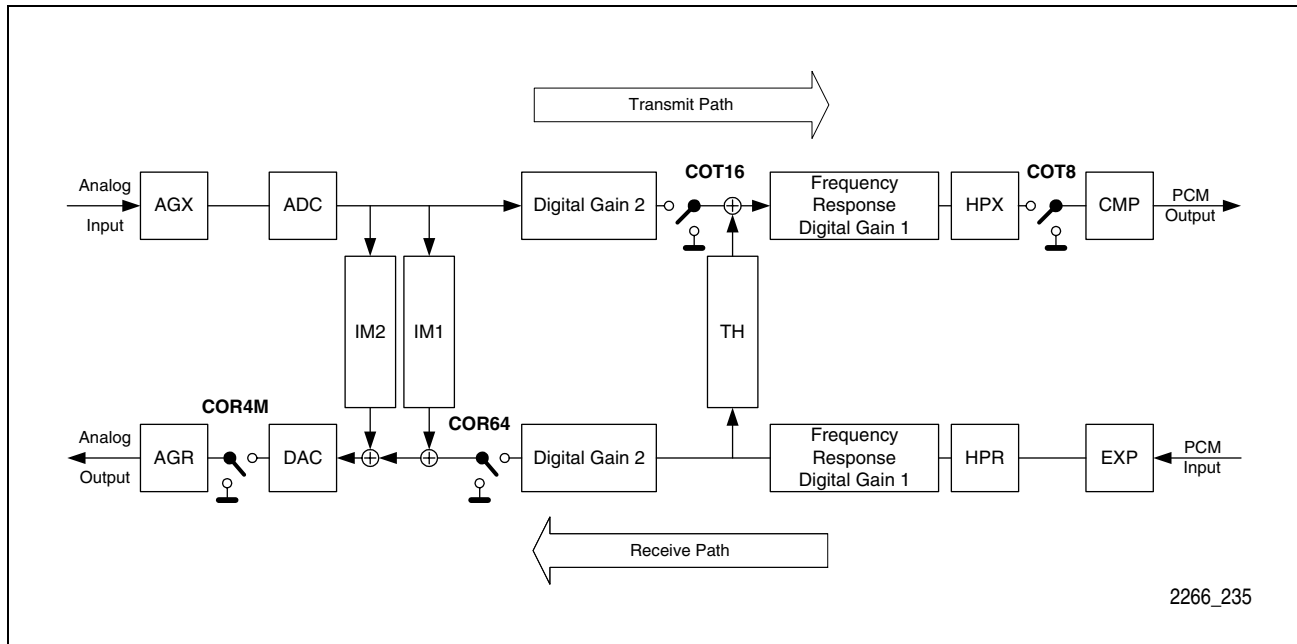

Figure 35 Cut-Off's

Table 36 Cut-Off Programming in Register CR2, Bits 7 to 5.

COT/R	Cut-Off's in the Transmit and the Receive Paths	
000	All Cut-offs disabled (Normal Operation).	
001	COT16	Cut Off Transmit path at 16 kHz (input of TH-Filter).
010	COT8	Cut Off Transmit path at 8 kHz (shortens the input of the compressor unit to ground, resulting in PCM idle codes in the transmit time slot).
101	COR4M	Cut Off Receive path at 4 MHz (POFI-output).
110	COR64	Cut Off Receive path at 64 kHz (IM-filter input).

10 Package Outlines

P-MQFP-64 (Plastic Metric Quad Flat Package)

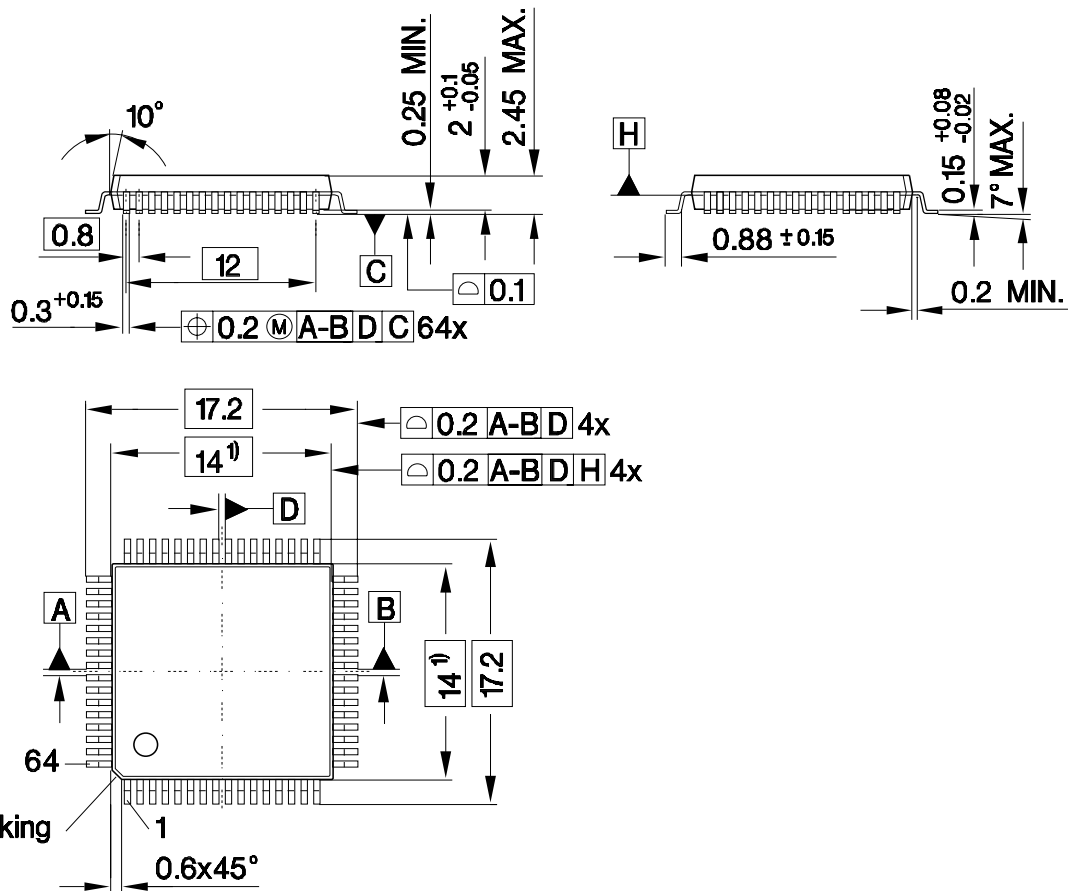

1) Does not include plastic or metal protrusion of 0.25 max. per side

GPM05250

Sorts of Packing

Package outlines for tubes, trays etc. are contained in our Data Book "Package Information".

SMD = Surface Mounted Device

Dimensions in mm

11 Glossary

AC	A lternating C urrent
ADC	A nalog-to- D igital C onverter
CMOS	C omplementary M etal O xide S emiconductor
CRAM	C oefficient R AM
DAC	D igital-to- A nalog C onverter
DC	D irect C urrent
DLC	D igital L oop C arrier
DSP	D igital S ignal P rocessor
DTMF	D ual T one M ulti F requency
FIR	F inite I mpulse R esponse
FTTC	F iber- T o- T he- C urb
IIR	I nfinite I mpulse R esponse
IOM-2	I SDN- O riented M odular 2 nd G eneration
ITU	I nternational T elecommunication U nion
ITU-T	I nternational T elecommunication U nion- T elecommunication Standardization Sector (formerly CCITT)
PBX	P rivate B ranch E xchange
PCM	P ulse C ode M odulation
PSTN	P ublic S witched T elephone N etwork
PTT	P ost T elephone T elegraph
QSICOS	Q uad S ICOFI C oefficient S oftware
RITL	R adio- I n- T he- L oop
RT	R emote T erminal
SICOFI	S ignal P rocessor C odec F ilter
SLIC	S ubscriber L ine I nterface C ircuit
t/r	tip/ring

Index

Symbols

μ -Law 2, 11, 14, 19, 30
 μ -Law mode 15, 22

Numerics

0 dBm0-Levels 14
 2-wire to 4-wire conversion 10
 8-bit time slots 2

A

A/ μ -Law 3
 A/D and D/A converters 11, 18, 26
 A/D converters 14, 23
 Absolute gain 17
 Absolute group delay 18
 Absolute maximum ratings 44
 AC transmission characteristics 27
 Accuracy of digital filters 10, 11
 ADC 2, 3, 11
 A-Law 2, 11, 14, 19, 30
 A-Law mode 15
 Ambient temperature 44
 Analog ground pins 8, 9, 29
 Analog I/O 2
 Analog input 13
 Analog input/output pins 29
 Analog Interface 3, 27, 28
 Analog interface 14, 46
 Analog Interface pins 29
 Analog loop programming 51
 Analog loops 3, 51
 Analog output 13
 Analog supply reference voltage 9
 Analog supply voltage 8
 Analog voice input/output 8
 Analog voltage levels 14
 Application hints 41
 Application Notes 1

AR 39
 Architecture 2
 Attenuation 18
 AX 39

B

Balancing filter 26
 Bi-directional signaling pins 8, 33
 Blocking capacitors 42
 Board design 42
 Board layout 43
 Byte-by-byte transfer 36

C

Ceramic capacitors 42
 Channel operating ranges 45
 Channel-pair 33
 Channels 2, 22, 37
 Channel-specific coefficients 39
 Channel-specific registers 11, 12, 37, 38
 Chip Select 6, 34
 Clock 11, 32, 33, 34
 Clock output signals 2
 Clock programming 33
 C-message 19
 Codec filter 2
 Coefficient calculation &
 configuration software 3
 Coefficient Operation (COP) command 40
 Coefficient operation commands 39
 Coefficient RAM 11, 34, 35, 37, 39
 Command sequences 36, 40
 Command type 40
 Commands 35
 Common configuration registers 11, 37, 38
 Compression 3
 Compressor 11
 Configuration of interfaces 27
 Configuration registers 35, 37
 Control Data input/output pins 34

Control data input/output pins	34	Digital, programmable filters	10
Conversion utilities	41	DIN	49
COP	40	DLC	4
COP command sequences	39	Double clocking mode timing.	48
Country-specific adaptations	10	DOUT	49
Coupling capacitors	27, 29, 46	Driving capability	3, 27
CR0 to CR5	37	DSP core	2, 3, 10, 11
CR0 to CR7	38	DTMF	3
CRAM	11, 34, 35, 37, 39, 40	Dynamic gain	3
CRAM structure	39	Dynamic range	11
Crosstalk	22		
CR-Registers	11	E	
CS#	34, 49	EASY 2466	3, 41
Cut-Off programming	53	EASY 2466 evaluation system	41
Cut-Off's	53	Echo	26
		Electrical characteristics	44
D		Evaluation boards	41
DAC	2, 3, 11	EVC50x	41
Data bytes	35	Expander	11
Data Clock	6	Expansion	3
Data clock	34	Extended Operation (XOP) command	40
Data input pins	6	Extended temperature range	2
Data output pins	6	External amplifier	27
Data pins	34	External components	26
Data rates	3, 11, 30		
Data receive pins	7	F	
Data transmit pins	7	Fiber-to-the-Curb Systems	4
DCLK	49	Filter capacitors	42
Debouncing functions	32, 33	Filter characteristics	10
Decimation	11	Filter coefficients	27
Detect specific tones	10	Filter coefficients storage	11
Development boards	3, 41	Filter structures	11
Digital filters	3	Flow diagram	16
Digital ground pins	6	Fluctuation	10
Digital input	13	Four-wire interface	10
Digital interface	45	Frame	30
Digital loop programming	52	Frame delay	30
Digital loops	3, 52	Frame synchronization clock	7, 30
Digital output	13	Frequency correction	11
Digital supply voltage	7	Frequency response	3, 18, 27
Digital switching & transmission system	2		

Frequency response corrections . . .	10, 16	Input voltage range (AC)	46
FRR	39	Input voltages	45
FRX.	39	INT12.	33
FSC.	47, 48	Interface description	27
Functional blocks	37	Interfaces.	37
G		Intermodulation	20
Gain	15, 26	Intermodulation distortion	20
Gain accuracy.	17	Internal registers	34
Gain deviations with input level	17	Interpolation.	11
Gain tracking.	17	Interrupt generation	33
Ground layer.	43	Interrupt output pins.	33
Ground pins	43	Interrupt pins	32
Ground plane	43	Interrupts	8
Ground-key detection	10	Inventory costs	4
Group delay	18, 26	ITU-T	3, 14, 16
Group delay absolute values	18	K	
Group delay distortion.	19	Key Systems	4
H		L	
Hardware filters.	11, 23	Level adjustments	10, 11
Hardware reset.	12	Level metering.	3, 10
Harmonic distortion.	20	Line characterization	10
High impedance state.	34	Linearity.	3, 11
Highway	11	Linecard functions	10
HW-Reset	12	Load capacities	14
I		Local requirements	10
I/O pins	32	Loop filters	10
Identification byte	35	M	
Idle channel noise.	19	Manufacturing test.	3
IM-filter	26, 39	Master clock	7, 33
Impedance matching	3, 10, 11, 16	Maximum signal levels	14
Independent filter structures.	2	Measurements.	41
Industry–standard PCM Interface	30	Microcontroller.	10
Input impedance	10, 29, 46	Microcontroller Interface	10, 34, 39, 40
Input leakage current	45, 46	Microcontroller interface timing	49
Input offset voltage	46	Microcontrollers	27
Input pins	12, 32		
Input resistance	27, 46		

N

Noise	19
Noise rejection	42
Non usable input	6
Non usable input/output	6
Not connected pins	6, 9

O

On-/off-hook detection	10
Operating conditions	16
Operating range	45
Operating state	12, 13
Operating states	12
Operation of interfaces	27
Operational description	12
Optimization	41
Out-of-band discrimination	23, 24
Out-of-band idle channel noise	25
Out-of-band signals	23, 24, 27
Output load	46
Output offset voltage	46
Output resistance	46
Output voltages	45
Overload compression	22
Overload point	14, 22, 27
Oversampling	11

P

Package	3
Package Outlines	54
Pair-Gain Systems	4
PCLK	47, 48
PCM clock	30
PCM data clock	7
PCM data format	30
PCM Highway A	7
PCM Highway B	7
PCM highways	2, 3, 27, 30
PCM interface	3, 14, 27
PCM interface pins	30

PCM interface timing	47, 48
PCM ports	11
Peak amplitude	14, 27
PEB 2466	1
Pin configuration	5
Pin definitions and functions	6
Pin descriptions	5
Pin diagram	5
PLL	11
Power dissipation	12, 13
Power dissipation (package)	44
Power On	12
Power spectral density	25
Power supply rejection ratio	45
Power-saving state	12
POWER-UP state	33
Product Brief	1
Product Overview	1
Programmable debouncing	3
Programmable digital filters	3
Programmable filters	26
Programmable frequency	13
Programmable tone generators	3
Programmer's Reference Manual	1
Programming overview	37
PSB 2132	1
PSB 2134	1
Psophometric	19

Q

QSICOS	3, 41
--------	-------

R

Radio-in-the-Loop Systems	4
Read access	35, 38
Read commands	35, 36
Receive data input pins	30
Receive delay	18
Receive path	10, 51, 52, 53
Reference voltage pin	9, 29

Register maps	38	Signaling status changes	32
Register model	37	Signal-to-noise performance	11
Register values	13	Signal-to-total distortion ratio	20, 21
Registers	11	Sine wave signal	14
Reset	7	Single clocking mode timing	47
Reset state	12, 13, 46	Single frequency distortion	22
Reset timing	46	SLIC	2, 3, 10, 16, 26, 27
RESET#	12	SLIC daughter cards	41
RESET# pin	46	SLIC interfaces	33
Resolution	11	SOP	40
Return loss	10	Specifications	16
Ring signals	10	Spikes	46
RITL	4	Standard temperature range	2
RST	12	Standby operating range	45
S		Standby state	12, 13
Sampling	34	State diagram	12
Sampling intervals	33	States	12, 13
Sampling slopes	30	Status Operation (SOP) command	40
Schmitt-Trigger input	46	Storage temperature	44
Serial input	13	Subscriber line interface circuits	2, 10, 27
Serial Interface	2	Subscriber lines	32
Serial Microcontroller Interface	10, 27, 34	Supervision and signaling functions	32
Serial output	13	Supply current	45
Sigma-delta	11	Supply voltage	3
Signal levels	3, 15	Supply voltage pins	29
Signal paths	53	Support tools	3, 41
Signal power transfer	10	SW-Reset	12
Signal processor	10	System diagnostics	3
Signal reflections	10	System tests	3
Signal rejection	23	T	
Signaling example	32	Tantalum capacitors	42
Signaling input pins	8, 33	Telco specification	27
Signaling input/output pins	11	Telephone line	27
Signaling Interface	10, 27, 32	Telephone linecard	10
Signaling Interface pins	33	Telephone subscriber loop	10
Signaling interface timing	50	Teletax filters	27
Signaling output pins	8, 33	Teletax pulses	23, 27
Signaling output timing	50	Test circuit	42
Signaling pins	2, 32	Test conditions	16
Signaling registers	33	Test loops	26, 51

Test modes	51	Write commands	35, 36
Test relays	10		
TG1 and TG2	39	X	
TH-filter	37, 39	XOP	40
Three-Wire access	36	XR0 to XR7	38
Time slot assignment	3, 11	XR-Registers	11
Time slots	2, 30		
Time to market	4		
Timing	47, 49, 50		
Timing diagrams	44		
Tip & ring	27		
Tone generators	3, 10		
Tool package	41		
Total distortion receive/transmit	20, 21		
Total gain calculation	15		
Transfer functions	27		
Transformer	3, 10, 27		
Transformer SLIC	27		
Transhybrid balancing	3, 10, 11, 16, 26		
Transhybrid loss	10, 26		
Transmission characteristics	10, 14, 16, 37		
Transmission system	41		
Transmit control output pins	30		
Transmit control pins	7		
Transmit data output pins	30		
Transmit delay	18		
Transmit path	10, 51, 52, 53		
Two-wire interface	10		
Types of commands	40		
V			
VIN-pins	27		
Voice channels	11		
Voltage levels	12		
VOUT-pins	27		
W			
Waiting time	36		
Website	1		
Write access	35, 38		

Infineon goes for Business Excellence

“Business excellence means intelligent approaches and clearly defined processes, which are both constantly under review and ultimately lead to good operating results.

Better operating results and business excellence mean less idleness and wastefulness for all of us, more professional success, more accurate information, a better overview and, thereby, less frustration and more satisfaction.”

Dr. Ulrich Schumacher

<http://www.infineon.com>

Published by Infineon Technologies AG