

# AP1053

## 10 TO 1000 MHz TO-8 CASCADABLE AMPLIFIER

**Typical Values**

<b>Low Noise</b> .....	<b>1.5 dB</b>
<b>High Output Level</b> .....	<b>+26.0 dBm</b>
<b>High Second Order I.P.</b> .....	<b>+58.0 dBm</b>
<b>High Dynamic Range</b> .....	<b>94 dB</b>
<b>High Efficiency</b>	
<b>High Performance Thin Film</b>	
<b>Standard Size TO-8 Package</b>	

**AP1053**

### AP1053

**TO-8 Package for Amplifiers**

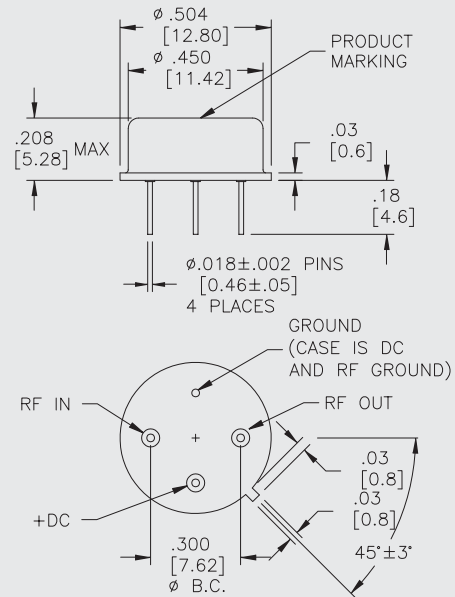

## SPECIFICATIONS\*

Parameter	Typical	Guaranteed	
		0 to 50 °C	-55 to +85 °C
<b>Frequency (Min.)</b>	<b>10-1000 MHz</b>	<b>10-1000 MHz</b>	<b>10-1000 MHz</b>
<b>Small Signal Gain (Min.)</b>			
10-450 MHz	10.5 dB	10.0 dB	9.0 dB
450-1000 MHz	11.0 dB	10.5 dB	10.0 dB
<b>Gain Flatness (Max.)</b>			
10-450 MHz	±0.2 dB	±0.4 dB	±0.5 dB
450-1000 MHz	±0.5 dB	±0.8 dB	±1.0 dB
<b>Noise Figure (Max.)</b>			
100-1000 MHz	1.5 <sup>^</sup> dB	2.5 <sup>^</sup> dB	3.0 <sup>^</sup> dB
<b>SWR (Max.)</b>	Input/Output	1.9:1	2.0:1
<b>Power Output (Min.)</b> @ 1dB comp.	+26.0 <sup>†</sup> dBm	+25.0 <sup>†</sup> dBm	+24.5 <sup>†</sup> dBm
<b>Reverse Isolation</b>	18.0 dB	—	—
<b>DC Current (Max.)</b>	100 mA	110.0 mA	115.0 mA

\* Measured in a 50-ohm system at +15 Vdc unless otherwise specified.  
<sup>^</sup> 2.0 dB higher below 200 MHz.   <sup>†</sup> 2.0 dBm lower below 50 MHz.

## INTERMODULATION PERFORMANCE

Typical @ 25 °C	+12 Volts	+15 Volts
<b>Second Order Harmonic Intercept Point</b> .....	+61 dBm	+64 dBm
<b>Second Order Two Tone Intercept Point</b> .....	+55 dBm	+58 dBm
<b>Third Order Two Tone Intercept Point</b> .....	+38 dBm	+39 dBm

## ABSOLUTE MAXIMUM RATINGS

<b>Storage Temperature</b> .....	-62 to +125 °C
<b>Maximum Case Temperature</b> .....	+125 °C
<b>Maximum DC Voltage</b> .....	+17 Volts
<b>Maximum Continuous RF Input Power</b> .....	+17 dBm
<b>Maximum Short Term Input Power (1 Minute Max.)</b> .....	100 Milliwatts
<b>Maximum Peak Power (3 μsec Max.)</b> .....	0.5 Watt
<b>Burn-in Temperature</b> .....	+100 °C
<b>Thermal Resistance<sup>1</sup> (θjc)</b> .....	+23 °C/Watt
<b>Junction Temperature Rise Above Case (Tjc)</b> .....	+34.2 °C

<sup>1</sup> Thermal resistance is based on total power dissipation.

### APS1053

**SMT0-8 Package for Amplifiers**

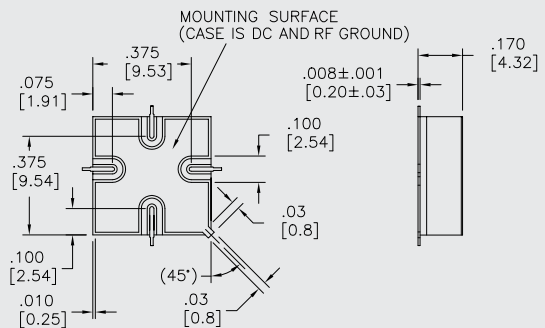
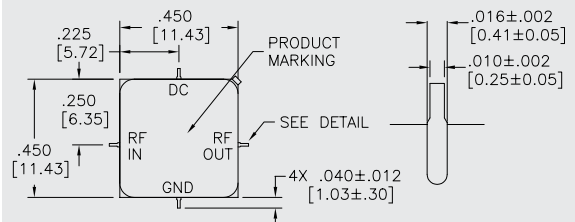

DIMENSIONS ARE IN INCHES [MILLIMETERS]

**TYPICAL PERFORMANCE**

**TYPICAL AUTOMATIC TEST DATA**

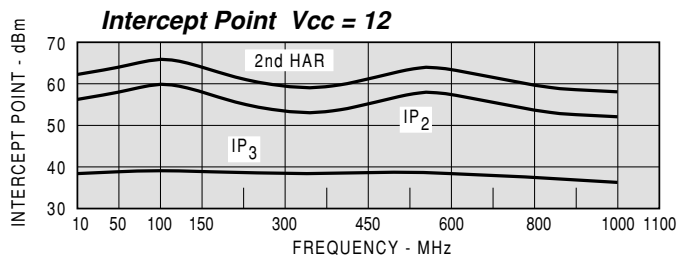
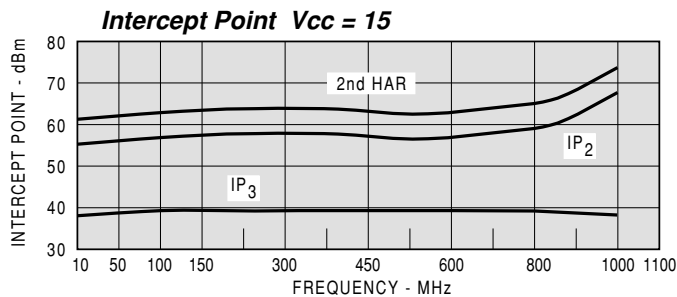
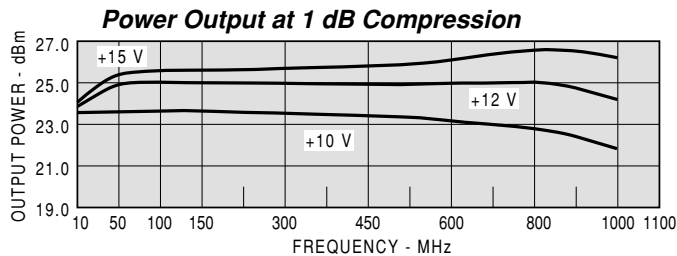
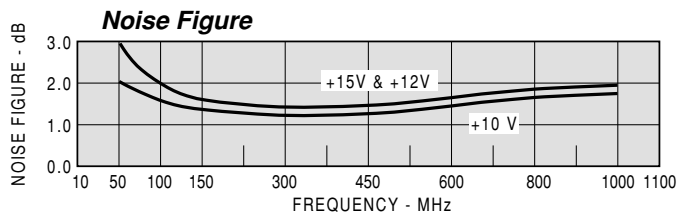
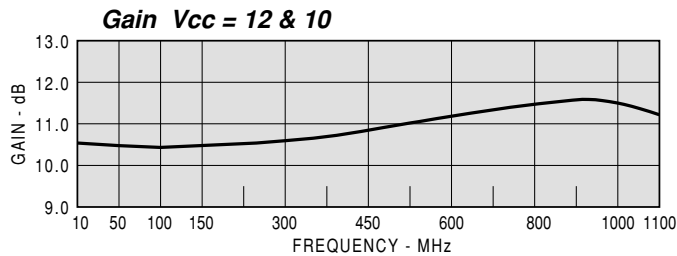
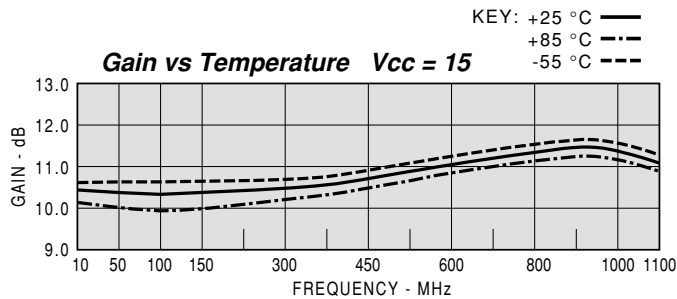

Model: AP1053			Vcc= +15V			lcc= 105.37	
FREQ	SWR	SWR	GAIN	PHASE	DELAY	REV/ISO	
MHZ	IN	OUT	DB	DEG	NSEC	DB	
10	1.66	1.18	10.50	-168	1.10	-17.8	
50	1.57	1.09	10.50	176	1.10	-17.8	
100	1.58	1.14	10.45	168	0.40	-17.8	
200	1.62	1.28	10.43	156	0.35	-17.9	
300	1.67	1.40	10.48	143	0.34	-17.9	
400	1.71	1.50	10.60	131	0.34	-18.0	
500	1.74	1.58	10.78	118	0.36	-17.9	
600	1.75	1.61	11.01	105	0.37	-17.7	
700	1.74	1.59	11.23	91	0.39	-17.5	
800	1.74	1.52	11.40	75	0.43	-17.5	
900	1.74	1.42	11.41	59	0.44	-17.4	
1000	1.79	1.37	11.26	42	0.46	-17.4	
1100	1.87	1.46	10.87	26	0.46	-17.7	

Model: AP1053			LINEAR S-PARAMETERS						lcc= 105.37	
			Vcc= +15V							
FREQ.	S11		S21		S12		S22			
MHZ	MAG	ANG	MAG	ANG	MAG	ANG	MAG	ANG		
10	0.25	-19	3.35	-168.2	0.129	174.6	0.08	79.7		
50	0.22	-5.7	3.35	175.6	0.129	172.9	0.04	74.5		
100	0.22	-5.7	3.33	168.4	0.129	166.8	0.07	72.2		
200	0.24	-8.8	3.32	155.7	0.127	154.7	0.12	62.7		
300	0.25	-15.6	3.34	143.3	0.127	142.6	0.17	53.5		
400	0.26	-25.6	3.39	131.0	0.126	131.2	0.20	44.7		
500	0.27	-37.9	3.46	118.1	0.128	119.7	0.22	36.2		
600	0.27	-54.0	3.55	104.8	0.130	108.1	0.23	27.6		
700	0.27	-74.4	3.65	90.6	0.133	96.0	0.23	20.1		
800	0.27	-99.3	3.72	75.1	0.134	83.1	0.21	15.8		
900	0.27	-128.1	3.72	59.1	0.136	70.1	0.17	17.4		
1000	0.28	-159.4	3.66	42.4	0.135	55.9	0.16	31.0		
1100	0.30	169.2	3.50	25.8	0.131	42.3	0.19	47.1		
1200	0.34	141	3.25	10.4	0.126	28.2	0.25	52.4		

Model: AP1053			Vcc= +12V			lcc= 103.31	
FREQ	SWR	SWR	GAIN	PHASE	DELAY	REV/ISO	
MHZ	IN	OUT	DB	DEG	NSEC	DB	
10	1.64	1.14	10.59	-169	1.10	-17.4	
50	1.57	1.11	10.57	176	1.10	-17.2	
100	1.57	.16	10.53	168	0.41	-17.3	
200	1.62	1.27	110.50	155	0.36	-17.4	
300	1.67	1.39	10.54	143	0.34	-17.4	
400	1.72	1.48	10.65	131	0.35	-17.5	
500	1.76	1.54	10.82	118	0.36	-17.4	
600	1.77	1.57	11.03	104	0.37	-17.4	
700	1.77	1.55	11.24	90	0.40	-17.2	
800	1.76	1.49	11.39	74	0.43	-17.2	
900	1.77	1.44	11.37	58	0.45	-17.1	
1000	1.82	1.48	11.18	42	0.46	-17.3	
1100	1.91	1.65	10.78	25	0.46	-17.6	

Model: AP1053			LINEAR S-PARAMETERS						lcc= 103.31	
			Vcc= +12V							
FREQ.	S11		S21		S12		S22			
MHZ	MAG	ANG	MAG	ANG	MAG	ANG	MAG	ANG		
10	0.24	-18.6	3.39	-168.5	0.135	176.4	0.07	111.7		
50	0.22	-5.3	3.38	175.5	0.137	172.8	0.05	129.7		
100	0.22	-5.2	3.36	168.2	0.136	166.4	0.07	108.3		
200	0.24	-8.4	3.35	155.4	0.135	153.6	0.12	83.2		
300	0.25	-15.2	3.36	143.0	0.134	140.8	0.16	68.3		
400	0.27	-25.4	3.41	130.5	0.133	128.7	0.19	57.0		
500	0.28	-38.1	3.47	117.6	0.134	116.8	0.21	47.4		
600	0.28	-54.7	3.56	104.1	0.136	104.7	0.22	39.0		
700	0.28	-75.7	3.65	89.9	0.138	91.8	0.22	32.9		
800	0.28	-101.2	3.71	74.4	0.138	78.4	0.20	31.4		
900	0.28	-130.5	3.70	58.3	0.139	64.9	0.18	37.2		
1000	0.29	-162.4	3.62	41.6	0.137	50.4	0.19	48.9		
1100	0.31	166.2	3.46	25.0	0.132	36.7	0.25	56.0		
1200	0.35	138.3	3.19	9.5	0.126	22.4	0.32	55.5		

Model: AP1053			Vcc= +10V			lcc= 100.32	
FREQ	SWR	SWR	GAIN	PHASE	DELAY	REV/ISO	
MHZ	IN	OUT	DB	DEG	NSEC	DB	
10	1.64	1.15	10.58	-169	1.10	-17.1	
50	1.57	1.16	10.54	175	1.10	-17.0	
100	1.58	1.19	10.49	168	0.41	-17.0	
200	1.63	1.29	10.46	155	0.36	-17.1	
300	1.69	1.39	10.50	143	0.35	-17.2	
400	1.74	1.48	10.61	130	0.35	-17.2	
500	1.78	1.54	10.78	117	0.36	-17.2	
600	1.80	1.55	10.99	103	0.38	-17.1	
700	1.80	1.54	11.17	89	0.40	-17.0	
800	1.80	1.50	11.31	73	0.44	-17.0	
900	1.82	1.50	11.26	57	0.45	-17.0	
1000	1.88	1.60	11.03	40	0.46	-17.2	
1100	1.97	1.82	10.59	24	0.46	-17.5	