

General Description

The SY20812D is a current-limited P-channel MOSFET power switch designed for USB load-switching or hot plug applications. Its ultra-low $R_{DS(ON)}$ and current limit protect the power source from overcurrent and short-circuit conditions. It incorporates overtemperature protection and reverse blocking functions.

An external resistor is used to configure the current limit threshold between 0.1A and 2A. An open-drain output can be used to detect fault events.

The device incorporates overtemperature protection and reverse blocking functions.

The SY20812 is available in a compact SOT23-5 package.

Features

- Input Voltage: 2.5V to 5.5V
- Extremely Low Power Path Resistance: 65mΩ (typical)
- Adjustable Current Limit from 100mA to 2A
- Overtemperature Shutdown and Automatic Retry
- Reverse Blocking (No Body Diode)
- Built-in Soft-Start
- RoHS Compliant and Halogen Free
- Compact: SOT23-5

Applications

- USB 3.1 Applications
- USB 3G Data Cards
- USB Dongles
- Mini PCI Accessories
- USB Chargers
- Public Place Multi-USB Chargers
- PC Card Hotswap Applications

Typical Application:

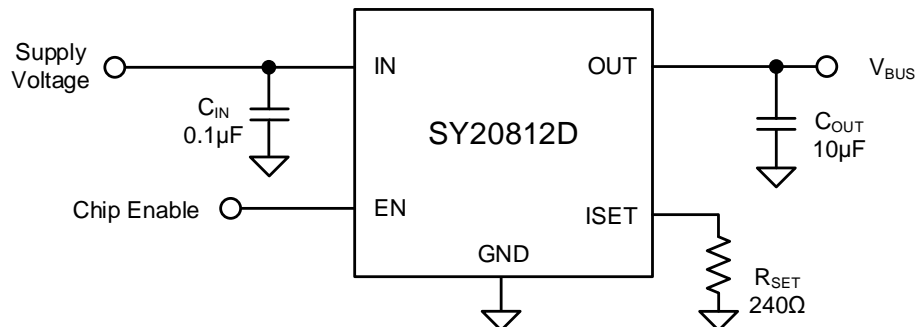

Note: If $0.1\mu\text{F}$ input capacitor will lead to large V_{IN} voltage spike, it is strongly recommended to add additional $10\mu\text{F}$ ceramic capacitor.

Figure 1. Schematic Diagram

Ordering Information

SY20812 □(□□□)

Package Code
Optional Spec Code

Ordering Number	Package Type	Top Mark
SY20812DAAT	SOT23-5	3Rxyz

Device code: 3R

(x=year code, y=week code, z= lot number code)

Pinout (Top View)

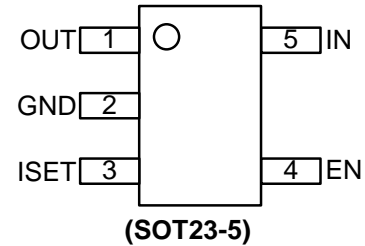

Pin Name	Pin number	Pin Description
OUT	1	Output pin, decoupled with a 10μF capacitor to GND.
GND	2	Ground pin.
ISET	3	Current limit programming pin. Connect a resistor R _{SET} from this pin to the ground to program the current limit: I _{LIM} (A)=240/R _{SET} (Ω)
EN	4	ON/OFF control. Pull high to enable. Do not leave floating.
IN	5	Input pin, decoupled with a 0.1μF capacitor to GND.

Absolute Maximum Ratings

Parameter (Note 1)	Min	Max	Unit
IN, OUT, ISET, OCB, EN	-0.3	6	V
Junction Temperature, Operating	-40	150	°C
Lead Temperature (Soldering, 10s)		260	
Storage Temperature	-65	150	

Thermal Information

Parameter (Note 3)	Typ	Unit
θ _{JA} Junction-to-ambient Thermal Resistance	106.4	°C/W
θ _{JC} Junction-to-case Thermal Resistance	41.7	
P _D Power Dissipation T _A = 25°C	0.94	W

Recommended Operating Conditions

Parameter (Note 3)	Min	Max	Unit
IN, OUT	2.5	5.5	V
All Other Pins	0	5.5	
Junction Temperature, Operating	-40	125	°C
Ambient Temperature	-40	85	

Electrical Characteristics

($V_{IN} = 5V$, $C_{OUT} = 10\mu F$, $T_J = 25^\circ C$, BOLD values indicate $-40^\circ C$ to $85^\circ C$, unless otherwise specified)

Parameter		Symbol	Test Conditions	Min	Typ	Max	Unit
Input Voltage Range		V_{IN}		2.5		5.5	V
IN UVLO Threshold		$V_{IN,UVLO}$				2.45	V
IN UVLO Hysteresis		$V_{IN,HYS}$			0.1		V
Shutdown Input Current		I_{SHDN}	Open load, switch off		0.1	5	μA
			Output grounded, switch off		0.1	5	μA
Reverse Leakage Current		$I_{RVS, LKG}$	IN ties to GND, $V_{OUT} = 5V$		0.1	5	μA
Reverse Blocking Threshold		V_{RBT}	$V_{OUT} - V_{IN}$		100		mV
Reverse Blocking Recovery Threshold		$V_{RBT,REC}$	$V_{OUT} - V_{IN}$		-30		mV
Quiescent Supply Current		I_Q	Open load, switch on		45	100	μA
FET $R_{DS(ON)}$		$R_{DS(ON)}$	$V_{IN} = 5V$ $I_{OUT} = 0.5A$		65	100	m Ω
Current Limit		I_{LIM}	$V_{OUT} = 4V$, $R_{SET} = 460\Omega$ (Note 5)	0.44	0.52	0.60	A
			$V_{OUT} = 4V$, $R_{SET} = 153.3\Omega$ (Note 5)	1.43	1.56	1.69	A
EN Threshold	Logic-Low Voltage	V_{IL}				0.4	V
	Logic-High Voltage	V_{IH}		1.0			V
EN Input Capacitor		C_{EN}	Note 4		1		pF
Output Turn-On Time		t_{ON}	$R_L = 10\Omega$, $C_L = 1\mu F$. Measure from EN ON until V_{OUT} reaches $V_{IN} \times 90\%$	1	2	5	ms
Output Turn-On Rise Time		t_R	$R_L = 10\Omega$, $C_L = 1\mu F$. Measure from $V_{OUT} = 10\%$ of V_{IN} to 90% of V_{IN}	1	2	5	ms
Output Turn-Off Time		t_{OFF}	$R_L = 10\Omega$, $C_L = 1\mu F$. Measure from EN OFF until V_{OUT} reaches $V_{IN} \times 10\%$		22		μs
Output Turn-Off Fall Time		t_F	$R_L = 10\Omega$, $C_L = 1\mu F$. Measure from $V_{OUT} = 90\%$ of V_{IN} to 10% of V_{IN}		21		μs
Thermal Shutdown Temperature		T_{SD}			150		$^\circ C$
Thermal Shutdown Hysteresis		T_{HYS}			20		$^\circ C$
Current-limit Response Time		$t_{OC,RES}$	$I_{LOAD} = 1.2 \times I_{LIMIT}$		25		μs
Short Circuit Response Time		t_{OC}	$I_{LOAD} = 1.5 \times I_{LIMIT}$		2		μs
Reverse Blocking Response Time		t_{RBT}	Note 4		800		ns



Note 1: Stresses beyond the “Absolute Maximum Ratings” may cause permanent damage to the device. These are stress ratings only. Functional operation of the device at these or any other conditions beyond those indicated in the operational sections of the specification is not implied. Exposure to absolute maximum rating conditions for extended periods may affect device reliability.

Note 2: θ_{JA} is measured in the natural convection at $T_A = 25^\circ\text{C}$ on a Silergy’s test board. Pin 2 of SOT23-5 package is the case position for θ_{JC} measurement.

Note 3: The device is not guaranteed to function outside its operating conditions.

Note 4: Guaranteed by design but not production tested.

Note 5: The current limit threshold is determined by $I_{LIMIT}=240\text{V}/R_{SET}$, where R_{SET} is in Ω .

Typical Performance Characteristics

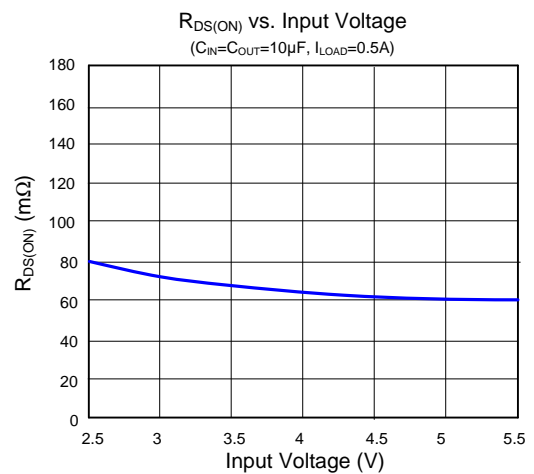
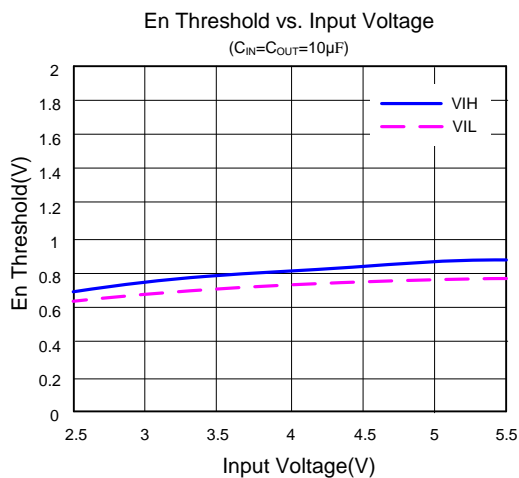
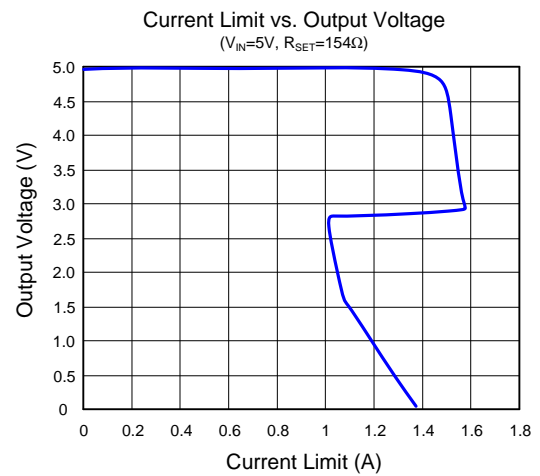
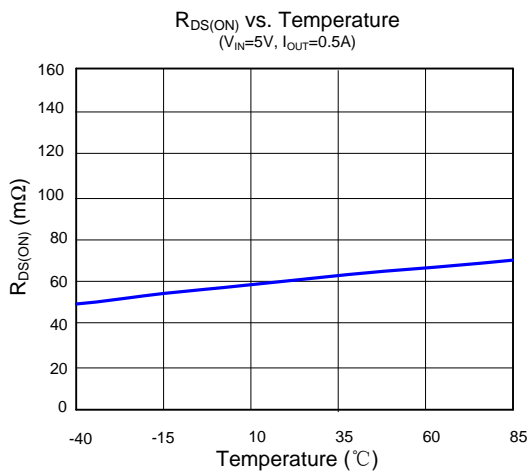
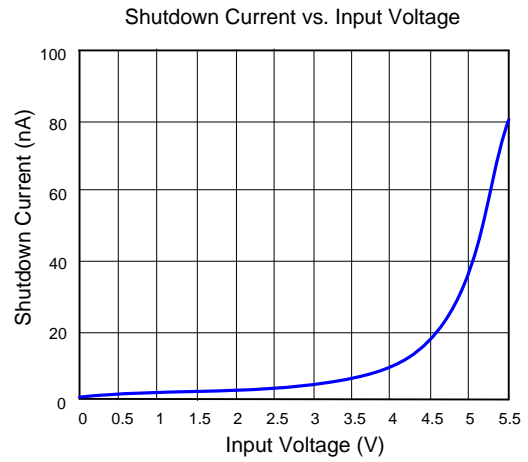
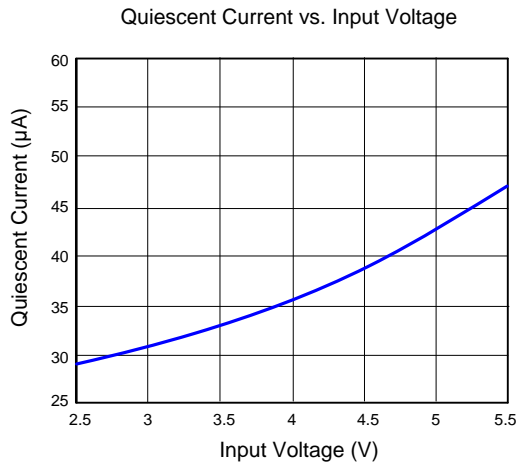

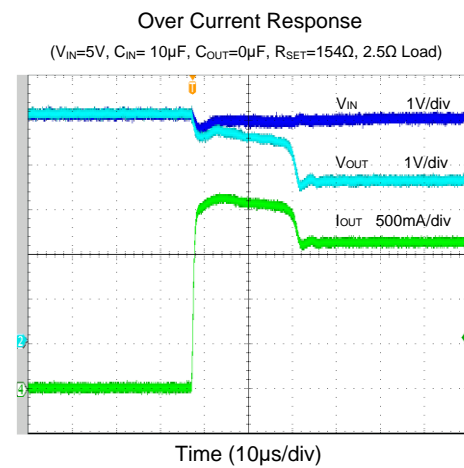
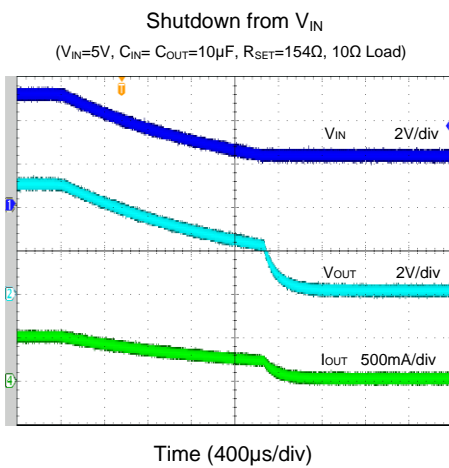
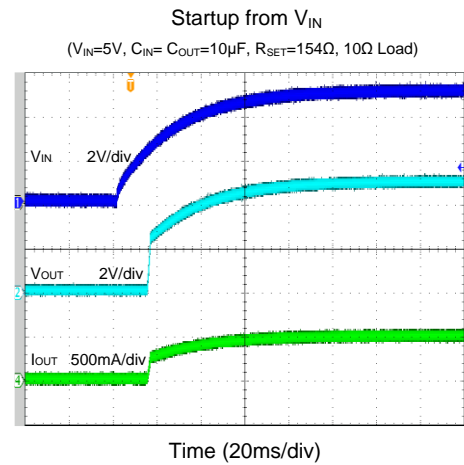
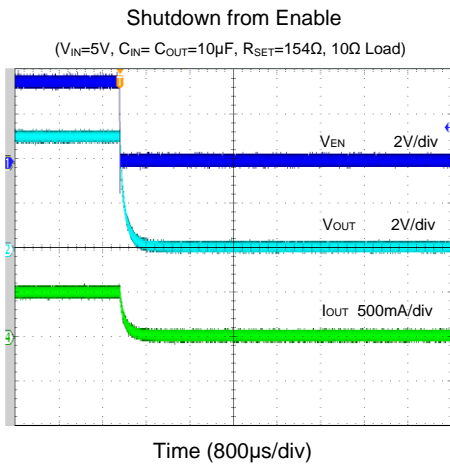
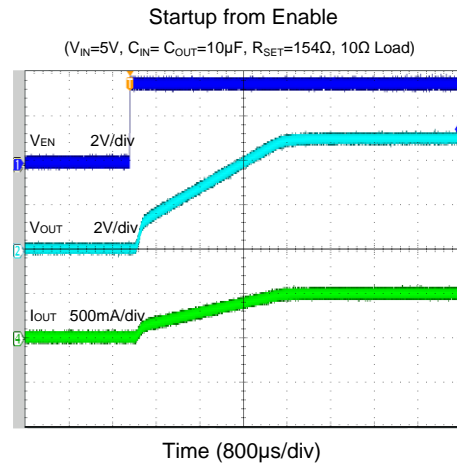
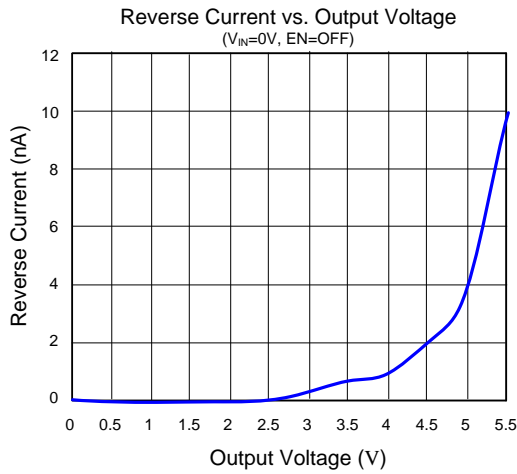

Short Circuit Response

($V_{IN}=5V$, $C_{IN}=C_{OUT}=10\mu F$)

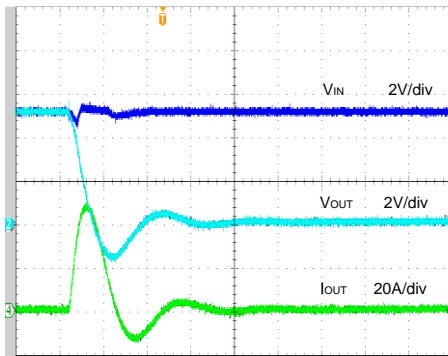

Time (10 μ s/div)

Application Information

The SY20812D is a current-limited P-channel MOSFET power switch designed for USB load-switch or hot-plug applications. It incorporates a reverse blocking function, which prevents current flow from OUT to IN when OUT is externally forced to a higher voltage than IN.

Overcurrent Protection:

The SY20812D supports current limit programming. Connect a resistor R_{SET} from the ISET pin to the ground to program the current limit:

$$I_{LIM} (A) = 240 / R_{SET} (\Omega)$$

The minimum current limit is 0.1A. A current limit beyond 2A is not recommended.

When the overcurrent condition is sensed, the gate of the pass switch is controlled to achieve a constant output current. If the overcurrent condition persists for a long time, the junction temperature may exceed 150°C, and overtemperature protection will shut down the part. Once the chip temperature drops below 130°C, the part will restart.

Table 1. Current Limit vs. R_{SET}

$R_{SET}(\Omega)$	Current Limit Threshold(mA)		
	MIN	TYP	MAX
460.0	440	520	600
153.3	1430	1560	1690

When in current limit and $V_{OUT} < 50\% \times V_{IN}$, the current limit of device will fold back to about $60\% \times I_{LIMIT}$ to decrease power dissipation.

Supply Filter Capacitor:

In order to prevent significant input voltage drop during hot-plug events, a 10 μ F ceramic capacitor from VIN to GND is strongly recommended. Higher capacitor values can further reduce input voltage droop. Without an input capacitor, an output short can cause ringing on the input, which could destroy the internal circuitry when the input transient exceeds the absolute maximum supply voltage, even for a short duration.

Output Filter Capacitor:

A 10 μ F output ceramic capacitor is recommended to be placed close to the device and output connector to reduce voltage drop during load transients. Higher output capacitor values can further reduce the drop during high-current applications.

Reverse Block Function:

The SY20812D integrates a reverse blocking function. Once the deviation voltage of OUT-IN exceeds 100mV, the reverse block function will be triggered. The power FET will be shut down in 800ns, blocking the reverse current flow from OUT to IN.

PCB Layout Guide:

For best performance of the SY20812D, the following guidelines must be followed:

1. Keep all VBUS traces as short and wide as possible and use at least 2 ounce copper for all VBUS traces.
2. Place the output capacitor as close to the connectors as possible to lower the impedance and inductance between the port and the capacitor and improve transient performance.
3. Place the input and output capacitors close to the device and connect them to the ground plane to reduce noise coupling.

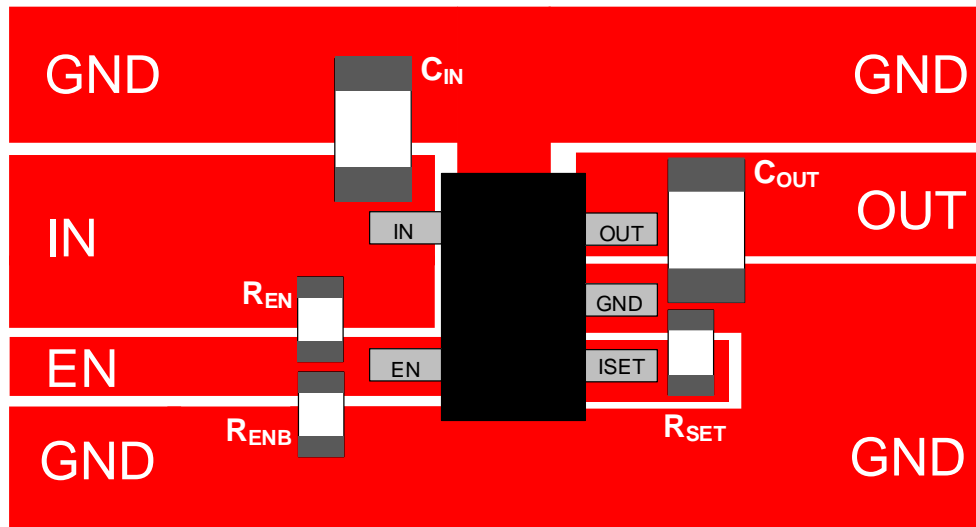
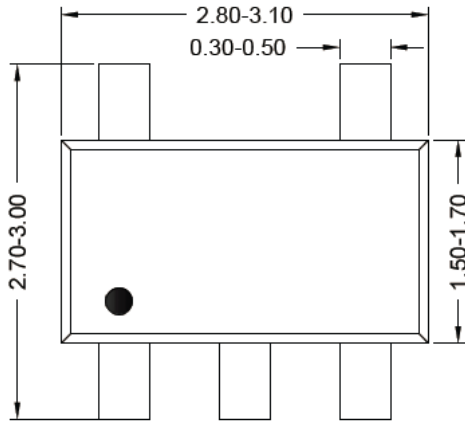
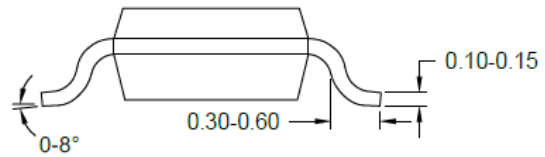

Figure 2. PCB Layout Example

SOT23-5 Package Outline & PCB Layout



Top View



Side View

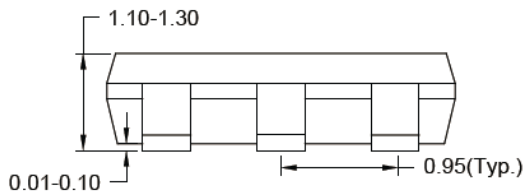

Front View

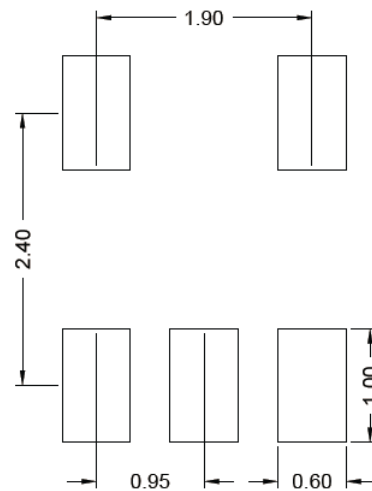

**Recommended PCB Layout
(Reference Only)**

Note: All dimensions are in millimeters and exclude mold flash and metal burr.

Tape and Reel Information

1. Tape Dimensions and Pin 1 Orientation

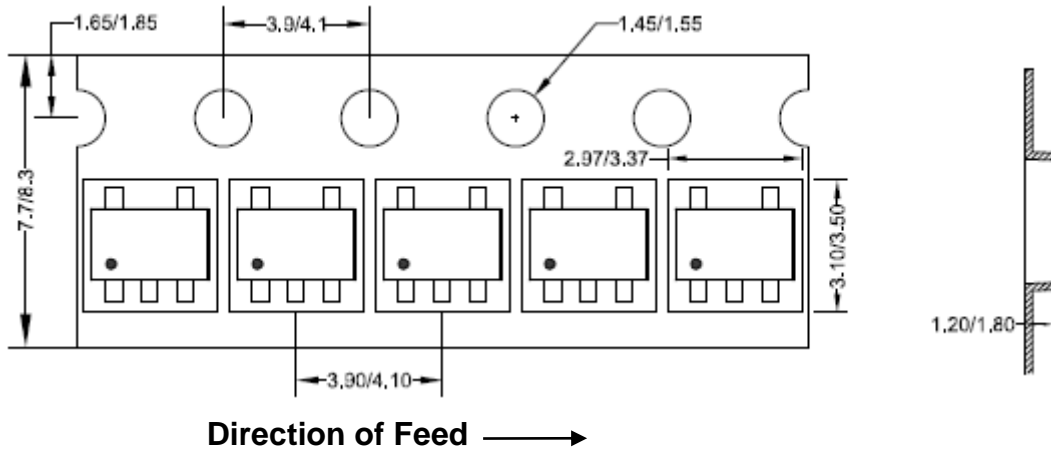

2. Reel Dimensions

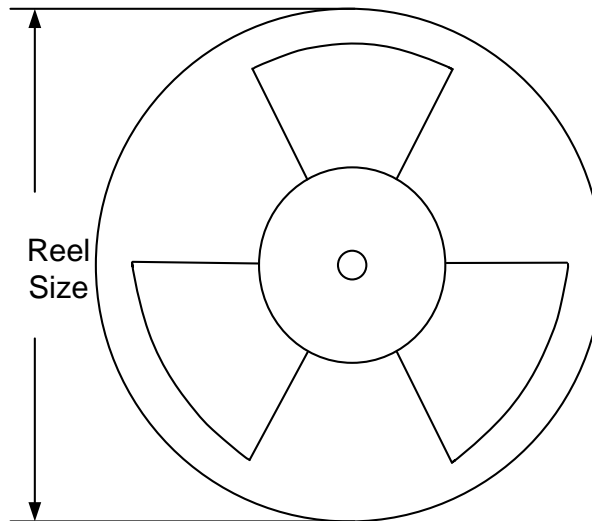

Package type	Tape width (mm)	Pocket pitch (mm)	Reel size (Inch)	Trailer length (mm)	Leader length (mm)	Qty per reel
SOT23-5	8	4	7"	280	160	3000

3. Others: NA

Revision History

The revision history provided is for informational purpose only and is believed to be accurate, however, not warranted. Please make sure that you have the latest revision.

Date	Revision	Change
Mar. 21, 2024	Revision 1.0	Language improvements for clarity.
Oct.11, 2021	Revision 0.9	Initial Release

IMPORTANT NOTICE

1. **Right to make changes.** Silergy and its subsidiaries (hereafter Silergy) reserve the right to change any information published in this document, including but not limited to circuitry, specification and/or product design, manufacturing or descriptions, at any time and without notice. This document supersedes and replaces all information supplied prior to the publication hereof. Buyers should obtain the latest relevant information before placing orders and should verify that such information is current and complete. All semiconductor products are sold subject to Silergy's standard terms and conditions of sale.
2. **Applications.** Application examples that are described herein for any of these products are for illustrative purposes only. Silergy makes no representation or warranty that such applications will be suitable for the specified use without further testing or modification. Buyers are responsible for the design and operation of their applications and products using Silergy products. Silergy or its subsidiaries assume no liability for any application assistance or designs of customer products. It is customer's sole responsibility to determine whether the Silergy product is suitable and fit for the customer's applications and products planned. To minimize the risks associated with customer's products and applications, customer should provide adequate design and operating safeguards. Customer represents and agrees that it has all the necessary expertise to create and implement safeguards which anticipate dangerous consequences of failures, monitor failures and their consequences, lessen the likelihood of failures that might cause harm and take appropriate remedial actions. Silergy assumes no liability related to any default, damage, costs or problem in the customer's applications or products, or the application or use by customer's third-party buyers. Customer will fully indemnify Silergy, its subsidiaries, and their representatives against any damages arising out of the use of any Silergy components in safety-critical applications. It is also buyers' sole responsibility to warrant and guarantee that any intellectual property rights of a third party are not infringed upon when integrating Silergy products into any application. Silergy assumes no responsibility for any said applications or for any use of any circuitry other than circuitry entirely embodied in a Silergy product.
3. **Limited warranty and liability.** Information furnished by Silergy in this document is believed to be accurate and reliable. However, Silergy makes no representation or warranty, expressed or implied, as to the accuracy or completeness of such information and shall have no liability for the consequences of use of such information. In no event shall Silergy be liable for any indirect, incidental, punitive, special or consequential damages, including but not limited to lost profits, lost savings, business interruption, costs related to the removal or replacement of any products or rework charges, whether or not such damages are based on tort or negligence, warranty, breach of contract or any other legal theory. Notwithstanding any damages that customer might incur for any reason whatsoever, Silergy' aggregate and cumulative liability towards customer for the products described herein shall be limited in accordance with the Standard Terms and Conditions of Sale of Silergy.
4. **Suitability for use.** Customer acknowledges and agrees that it is solely responsible for compliance with all legal, regulatory and safety-related requirements concerning its products, and any use of Silergy components in its applications, notwithstanding any applications-related information or support that may be provided by Silergy. Silergy products are not designed, authorized or warranted to be suitable for use in life support, life-critical or safety-critical systems or equipment, nor in applications where failure or malfunction of a Silergy product can reasonably be expected to result in personal injury, death or severe property or environmental damage. Silergy assumes no liability for inclusion and/or use of Silergy products in such equipment or applications and therefore such inclusion and/or use is at the customer's own risk.
5. **Terms and conditions of commercial sale.** Silergy products are sold subject to the standard terms and conditions of commercial sale, as published at <http://www.silergy.com/stdterms>, unless otherwise agreed in a valid written individual agreement specifically agreed to in writing by an authorized officer of Silergy. In case an individual agreement is concluded only the terms and conditions of the respective agreement shall apply. Silergy hereby expressly objects to and denies the application of any customer's general terms and conditions with regard to the purchase of Silergy products by the customer.
6. **No offer to sell or license.** Nothing in this document may be interpreted or construed as an offer to sell products that is open for acceptance or the grant, conveyance or implication of any license under any copyrights, patents or other industrial or intellectual property rights. Silergy makes no representation or warranty that any license, either express or implied, is granted under any patent right, copyright, mask work right, or other intellectual property right. Information published by Silergy regarding third-party products or services does not constitute a license to use such products or services or a warranty or endorsement thereof. Use of such information may require a license from a third party under the patents or other intellectual property of the third party, or a license from Silergy under the patents or other intellectual property of Silergy.

For more information, please visit: www.silergy.com

©2021 Silergy Corp.

All Rights Reserved.