

General Description

The SY86201E is an ultra-low $R_{DS(ON)}$ power distribution switch with current limit to protect the power source from over current and short circuit conditions. It incorporates overtemperature protection and a reverse blocking function.

The SY86201E is available in either DFN2x2-6 or SOT23-6 package.

Applications

- USB 3.1 Applications
- USB 3G Data Cards
- USB Dongles
- Mini PCI Accessories
- USB Chargers
- Multi-USB Chargers
- PC Card Hot-Swap Applications

Features

- Input Voltage: 2.5V to 5.5V
- Extremely Low Power Path Resistance: 65mΩ (Typ.)
- Adjustable Current Limit up to 2A
- Reverse Blocking (No Body Diode)
- Fast Reverse Recovery
- Fault Flag (OCB) Output for Over Current and Fault Conditions
- During Shutdown, OUT Can Be Forced Higher than IN
- Built-In Soft-Start
- MSL1
- RoHS Compliant and Halogen Free
- Compact Package Minimizes Board Space: DFN2x2-6/ SOT23-6

Typical Application

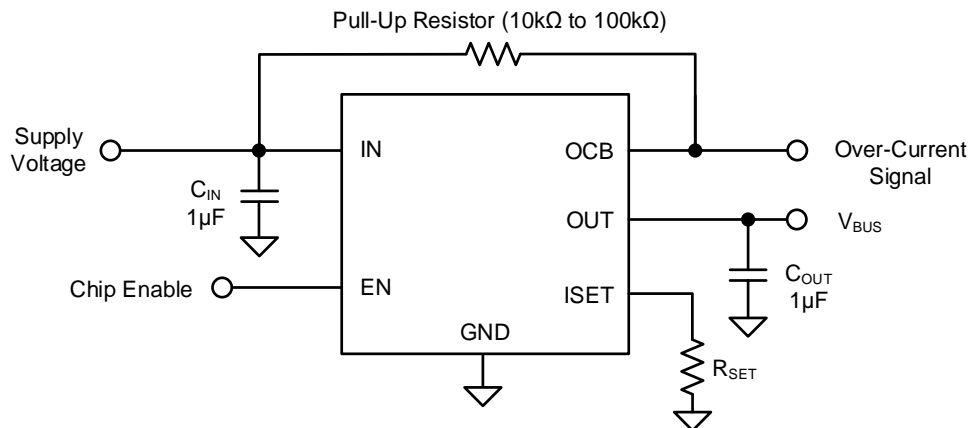

Figure1. Schematic Diagram

Ordering Information

Ordering Part Number	Package Type	Top Mark
SY86201EDED	DFN2x2-6 RoHS Compliant and Halogen Free	KBBxyz
SY86201EABT	SOT23-6 RoHS Compliant and Halogen Free	HJRxyz

x=year code, y=week code, z= lot number code

Pinout (Top View)

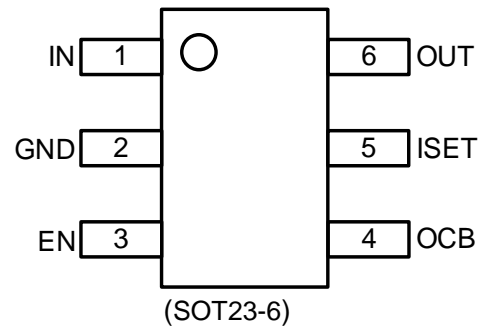
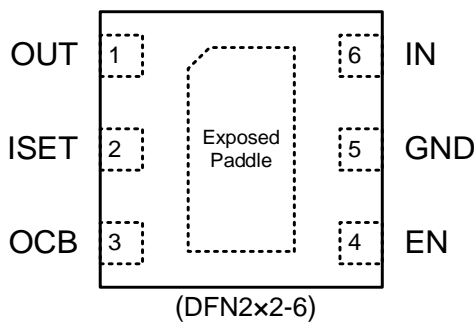

Pin Description

Pin Name	Pin Number		Pin Description
	DFN2x2-6	SOT23-6	
OUT	1	6	Output pin, decoupled with a 1 μ F capacitor from the IN to the GND, as close to the IC as possible.
ISET	2	5	Current limit programming pin. Connect a resistor R _{ISET} from this pin to ground to program the current limit. Recommended 13k Ω \leq R _{ISET} \leq 232 k Ω
OCB	3	4	Active low, open-drain fault flag. Asserted during over current or over temperature.
EN	4	3	ON/OFF control. Do not leave floating. A logic high turns on the power switch.
GND	5, Exposed Paddle	2	Ground pin.
IN	6	1	Input pin, decoupled with a 1 μ F capacitor from the IN to the GND, as close to the IC as possible.

Block Diagram

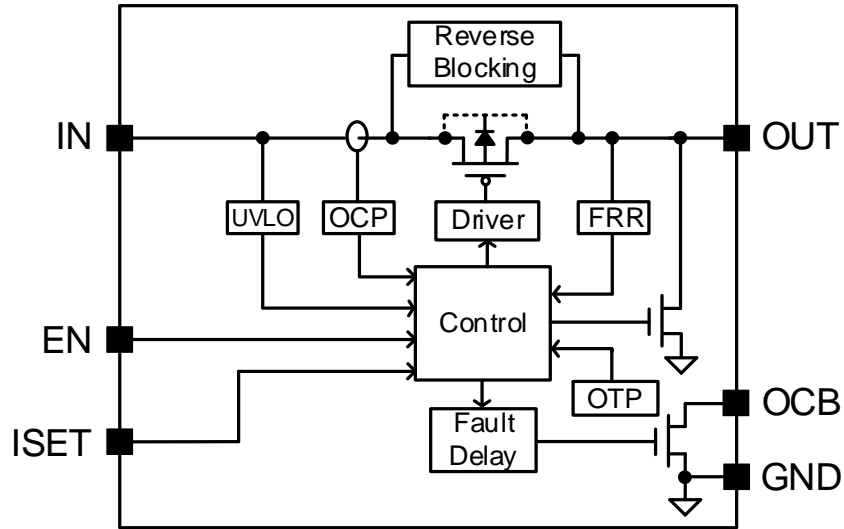

Figure2. Block Diagram

Absolute Maximum Ratings

Parameter (Note1)	Min	Max	Unit
IN, OUT, ISET, OCB, EN	-0.3	6	V
Lead Temperature (Soldering, 10 sec.)		260	°C
Junction Temperature, Operating	-40	150	
Storage Temperature	-65	150	

Thermal Information

Parameter (Note2)	Typ	Unit
θ_{JA} Junction-to-ambient Thermal Resistance (DFN2x2-6/ SOT23-6)	51.5 / 89.8	°C/W
θ_{JC} Junction-to-case Thermal Resistance (DFN2x2-6/ SOT23-6)	8.6 / 9.9	
P_D Power Dissipation $T_A = 25^\circ\text{C}$ (DFN2x2-6/ SOT23-6)	1.9 / 1.1.	W

Recommended Operating Conditions

Parameter (Note 3)	Min	Max	Unit
IN, OUT	2.5	5.5	V
ISET, OCB, EN	0	5.5	
Junction Temperature, Operating	-40	125	°C
Ambient Temperature	-40	85	

Electrical Characteristics

($V_{IN} = 5V$, $C_{OUT} = 10\mu F$, $T_J = -40^\circ C$ to $125^\circ C$, typical values are at $T_J = 25^\circ C$ unless otherwise specified (Note 4))

Parameter	Symbol	Test Conditions	Min	Typ	Max	Unit
Input Voltage Range	V_{IN}		2.5		5.5	V
IN UVLO Threshold	$V_{IN,UVLO}$				2.45	V
IN UVLO Hysteresis	$V_{IN,HYS}$	$T_J = 25^\circ C$		0.14		V
Shutdown Input Current	I_{SHDN}	Open load, switch off $-40^\circ C \leq T_J \leq 85^\circ C$		0.1	5	μA
		Output grounded, switch off $-40^\circ C \leq T_J \leq 85^\circ C$		0.1	5	μA
Reverse Leakage Current		IN tie to GND, $V_{OUT} = 5V$ $-40^\circ C \leq T_J \leq 85^\circ C$		0.1	5	μA
Reverse Blocking Threshold	V_{RBT}	IN tied to GND, $V_{OUT} = 5V$		100		mV
Reverse Blocking Recovery Threshold	V_{RBT_REC}	$V_{OUT} - V_{IN}$		-30		mV
Quiescent Supply Current	I_Q	Open load, switch on		45	100	μA
FET $R_{DS(ON)}$	$R_{DS(ON)}$	$V_{IN} = 5V$, $I_{OUT} = 0.5A$		65	100	m Ω
Current Limit Threshold	I_{LIM4}	$R_{SET} = 15k\Omega$	1600	1740	1880	mA
		$R_{SET} = 49.9k\Omega$	490	540	590	
		$R_{SET} = 210k\Omega$	130	150	170	
		ISET shorted to IN	65	90	115	
EN/ENB Threshold	Logic-Low Voltage	V_{IL}			0.4	V
	Logic-High Voltage	V_{IH}	1.0			V
EN Input Capacitor	C_{EN}	(Note 5)		1		pF
EN Leakage Current	I_{ENLK}				1	μA
Output Turn On Rise Time	t_R	$R_L = 100\Omega$, $C_L = 1\mu F$. Measure from $V_{OUT} = 10\%$ of V_{IN} to 90% of V_{IN}	1.9	2.7	3.7	ms
Output Turn Off Fall Time	t_F	$R_L = 100\Omega$, $C_L = 1\mu F$. Measure from $V_{OUT} = 90\%$ of V_{IN} to 10% of V_{IN}		126		μs
OCB Low Resistance	R_{OCB}	$V_{IN} = 5V$, $I_L = 10\mu A$		9		Ω
		$V_{IN} = 3.3V$, $I_L = 10\mu A$		12		
OUT Shutdown Discharge Resistance	R_{DSG}	EN=0V, $V_{OUT} = 0.1V$	75	100	145	Ω
OCB Leakage Current	I_{LKG_OCB}	$V_{OCB} = 5V$		0.01	1	μA
Fast Reverse Recovery Time	t_{FRR}	$V_{IN} = 3.3V$, $V_{OUT} = 3.5V$, $C_L = 1\mu F$, OUT= 100 Ω to GND. Remove 3.5V from OUT. Measure time from V_{OUT} thru 2.9V to $V_{OUT} = 3.2V$ (Note 5)			50	μs
Current-limit Response Time	t_{OC_res}	$I_{LOAD} = 1.2I_{LIMIT}$ (Note 5)		15		μs
Over Current Flag Response Time	t_{OCB}	$I_{LOAD} = 1.2I_{LIMIT}$		10		ms

Parameter	Symbol	Test Conditions	Min	Typ	Max	Unit
Short Circuit Response Time	t _{OC}	I _{LOAD} =1.5I _{LIMIT} (Note 5)		2		μs
Reverse Blocking Response Time	t _{RBT}	(Note 5)		800		ns
Thermal Shutdown Temperature	T _{SD}	(Note 5)		150		°C
Thermal Shutdown Hysteresis	T _{HYS}	(Note 5)		20		°C

Note 1: Stresses beyond the “Absolute Maximum Ratings” may cause permanent damage to the device. These are stress ratings only. Functional operation of the device at these or any other conditions beyond those indicated in the operational sections of the specification is not implied. Exposure to absolute maximum rating conditions for extended periods may affect device reliability.

Note 2: θ_{JA} is measured in the natural convection at T_A = 25°C on a Silergy’s test board.

Note 3: The device is not guaranteed to function outside its operating conditions.

Note 4: Unless otherwise stated, limits are 100% production tested under pulsed load conditions such that T_A ≅ T_J = 25°C. Limits over the operating temperature range (see recommended operating conditions) and relevant voltage range(s) are guaranteed by design, test, or statistical correlation.

Note5: Guaranteed by design but not production tested.

Typical Performance Characteristics

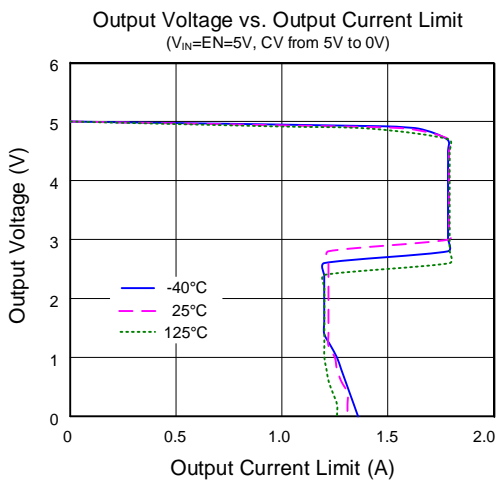
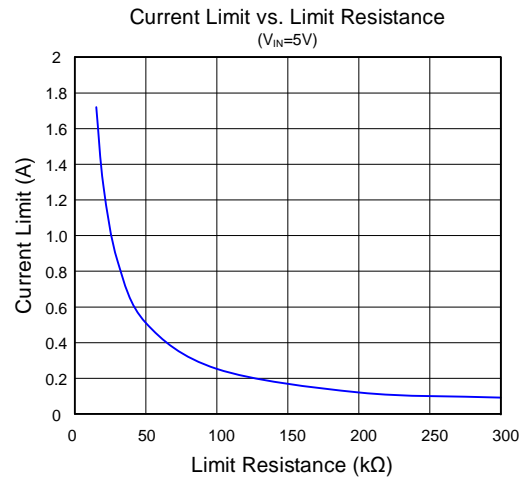
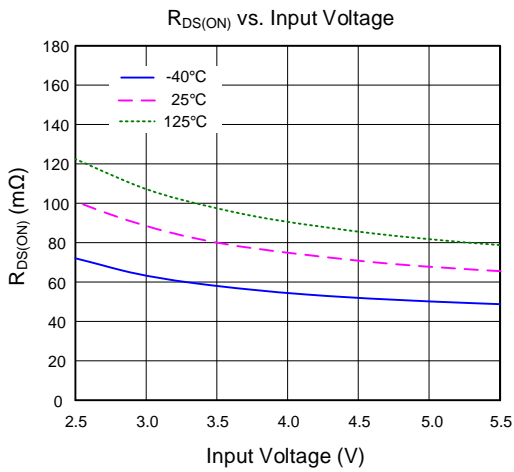
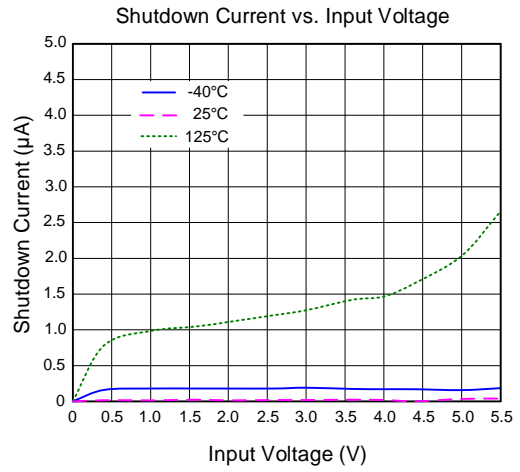
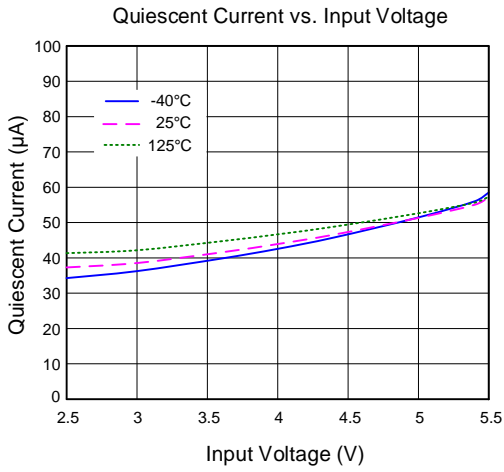

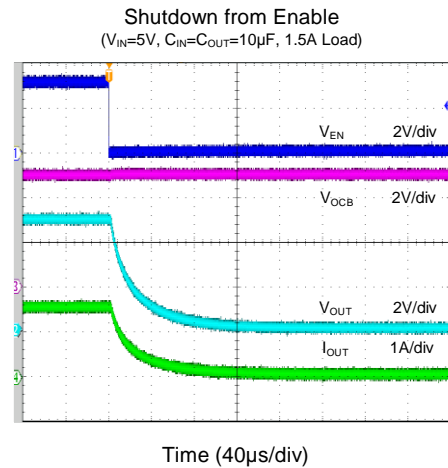
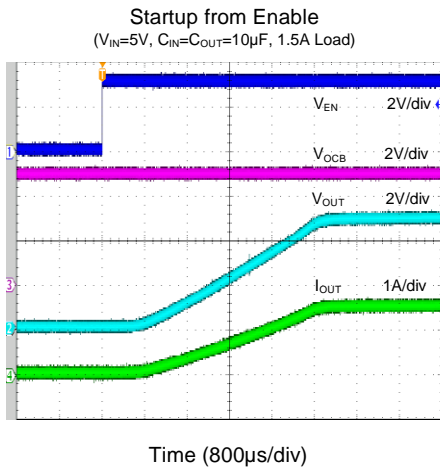
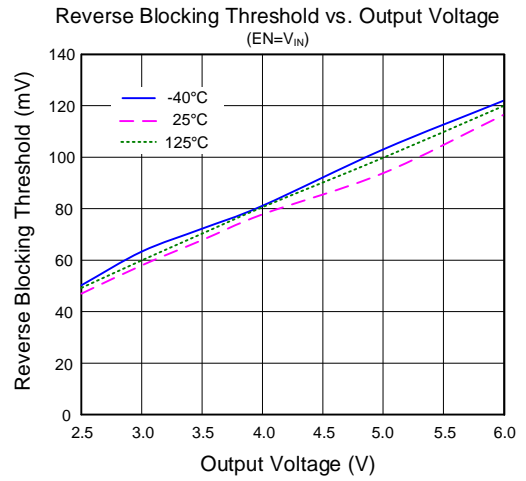
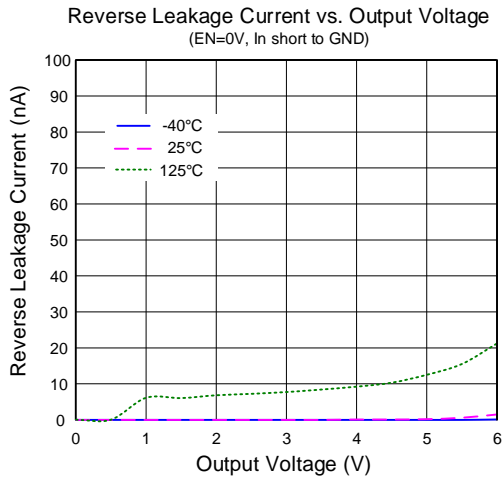
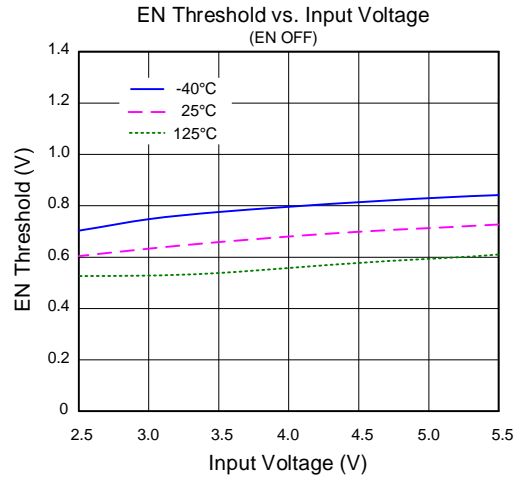
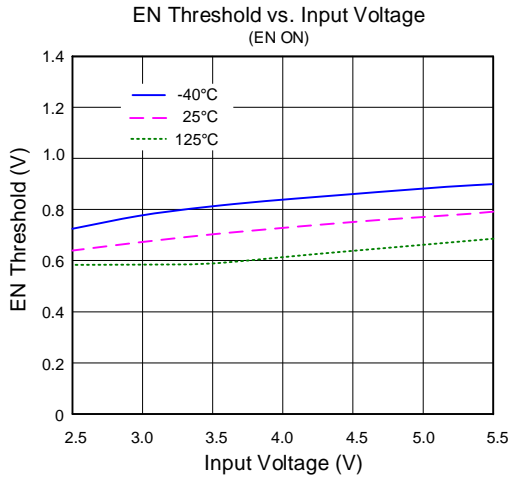

Startup from IN
($V_{IN}=5V$, $C_{IN}=C_{OUT}=10\mu F$, 1.5A Load)

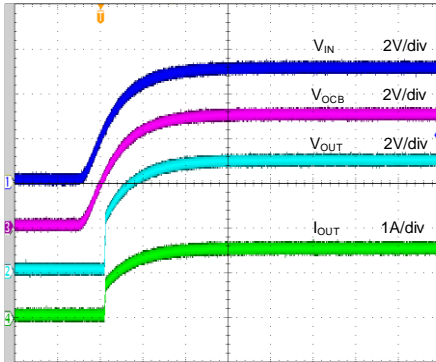

Time (40ms/div)

Shutdown from IN
($V_{IN}=5V$, $C_{IN}=C_{OUT}=10\mu F$, 1.5A Load)

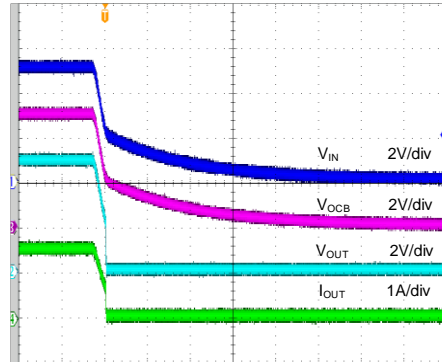

Time (100ms/div)

Over Current Response
($V_{IN}=5V$, $C_{IN}=10\mu F$, $C_{OUT}=0\mu F$, Null load \rightarrow 2.5Ω Load)

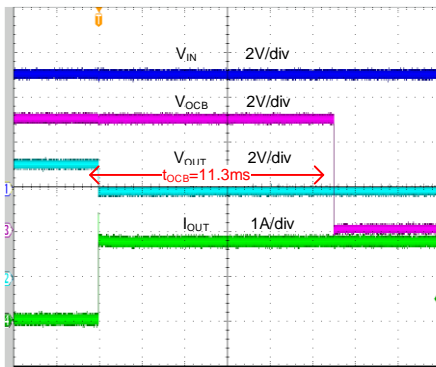

Time (2ms/div)

Current limit Response Time
($V_{IN}=5V$, $C_{IN}=10\mu F$, $C_{OUT}=0\mu F$, Null load \rightarrow 2.5Ω Load)

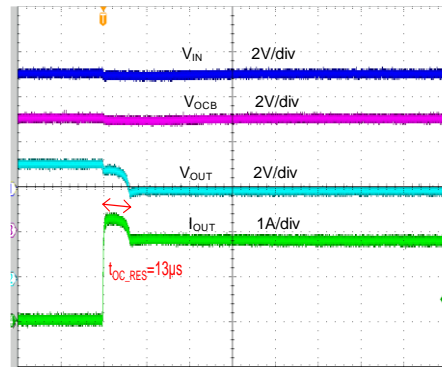

Time (20μs/div)

Fast Reverse Blocking Recovery Response
($V_{IN}=3.3V$, $V_{OUT}=3.5V$ removes, $C_{IN}=1nF$, $C_{OUT}=1\mu F$, Load=100Ω)

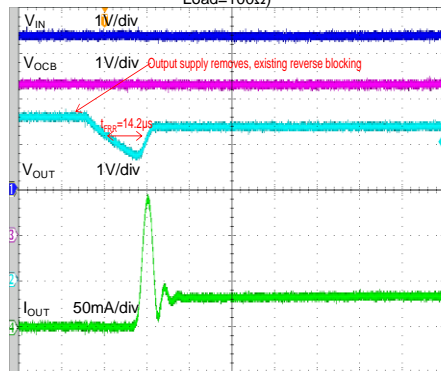

Time (20μs/div)

Short Circuit
($V_{IN}=EN=6V$, $R_{SET}=15k\Omega$ (1.7A))

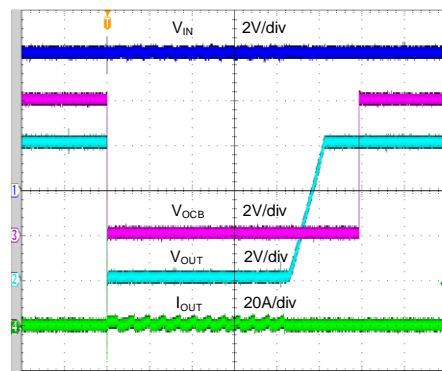

Time (4ms/div)

Operation

The SY86201E is a current limited power switch designed for USB load-switching or hot-plug applications. It incorporates overtemperature protection and reverse blocking function, to prevent current flow from OUT to IN when OUT is externally forced to a higher voltage than IN.

Over Current Protection

The SY86201E supports Current Limit programming. Connect a resistor R_{ISET} from the ISET pin to ground to program the current limit:

$$I_{LIM(MAX)}(mA) = \frac{27633V}{R_{ISET}(k\Omega)} + 37mA$$

$$I_{LIM(MEAN)}(mA) = \frac{25697V}{R_{ISET}(k\Omega)} + 27mA$$

$$I_{LIM(MIN)}(mA) = \frac{23760V}{R_{ISET}(k\Omega)} + 16mA$$

where

$$13\text{ k}\Omega \leq R_{ISET} \leq 232\text{ k}\Omega$$

While the maximum recommended value of R_{ISET} is 232 k Ω , there is one additional configuration that allows for a lower current-limit threshold. The ISET pin may be connected directly to IN to provide a 90 mA (typical) current limit threshold. Additional low-ESR ceramic capacitance may be necessary from IN to GND in this configuration to prevent unwanted noise from coupling into the sensitive ISET circuitry.

The current limit of device will be folded back at about 60% \times I_{LIMIT} to decrease power dissipation when $V_{OUT} < 60\% \times V_{IN}$.

When the over current condition is sensed, the gate of the pass switch is modulated to achieve constant output current. If the over current condition persists for a long time, the junction temperature may exceed 150°C, and over-temperature protection will shut down the part. Once the chip temperature drops below 130°C, the part will restart.

Short Circuit Protection

When detecting a critical overcurrent situation, the device initiates a rapid response to turn off the power FET within 2 μ s. The built-in fast trip comparator uses an adjustable threshold (I_{SC}) set to 1.5 \times I_{LIM} . This feature allows the user to customize the fast trip threshold, providing the flexibility that a fixed threshold might not offer.

Fault Flag(OCB)

The OCB output is asserted (active low) when thermal shutdown protection is triggered or an overcurrent condition persists for more than 10ms. The output remains asserted until the fault condition is removed. Connecting a heavy capacitance load to an enabled device can cause a momentary over current condition.

Supply Filter Capacitor

In order to prevent the input voltage spike which could destroy the internal circuitry when the input transient exceeds the absolute maximum supply voltage during output short or other load transient situation, a 1 μ F ceramic capacitors from V_{IN} to GND is strongly recommended. Higher capacitor values could reduce the voltage spike on the input further.

Output Filter Capacitor

A 1 μ F output ceramic capacitor should be placed close to the device and output connector to reduce voltage drop during load transient. Higher values of output capacitor can be used to further reduce the droop in high current applications.

Reverse Blocking Function

The SY86201E integrates a reverse blocking function. When the voltage at the OUT pin exceeds the voltage at the IN pin by 100mV, the reverse block function is triggered. The power MOSFET will shut down within 1.3 μ s block the reverse current flow from OUT to IN.

The SY86201E integrates a fast reverse blocking recovery function, which enables V_{OUT} recovery to 3.2V within 50 μ s once V_{OUT} drops 30mV lower than V_{IN} after the device is already operating in reverse blocking mode.

Schematic

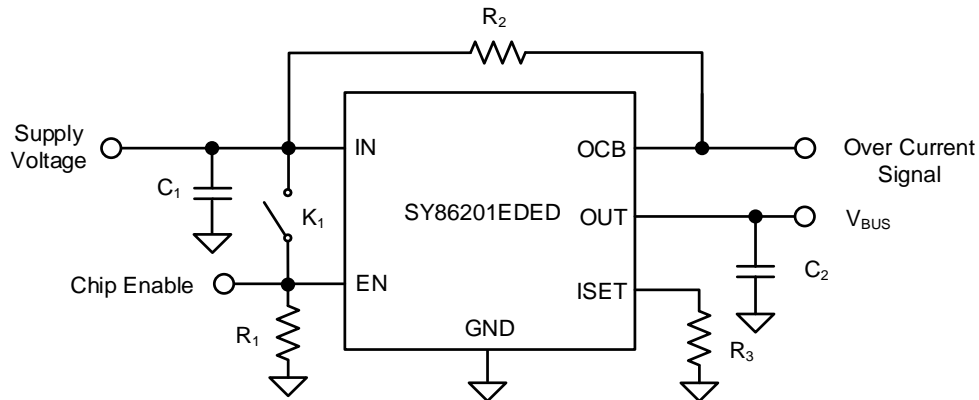

BOM List

Reference Designator	Description	Part Number	Manufacturer
C ₁	1μF/25V, 0603	GRM21BR71E105K	Murata
C ₂	1μF/25V, 0603	GRM21BR71E105K	Murata
R ₁	1MΩ, 0603	RC0603FR-071ML	YAGEO
R ₂	100KΩ, 0603	RC0603FR-07100KL	YAGEO
R ₃	15KΩ, 0603	RC0603FR-0715KL	YAGEO

PCB Layout Guide

For optimal performance of the SY86201E, the following guidelines must be adhered to:

- 1) Keep all VBUS traces as short and wide as possible and use 2 ounce copper traces.
- 2) Place the output capacitor as close to the connectors as possible to lower impedance (mainly inductance) between the port and the capacitor and improve transient performance.
- 3) Input and output capacitors should be placed closed to the IC and connected to ground plane to reduce noise coupling.

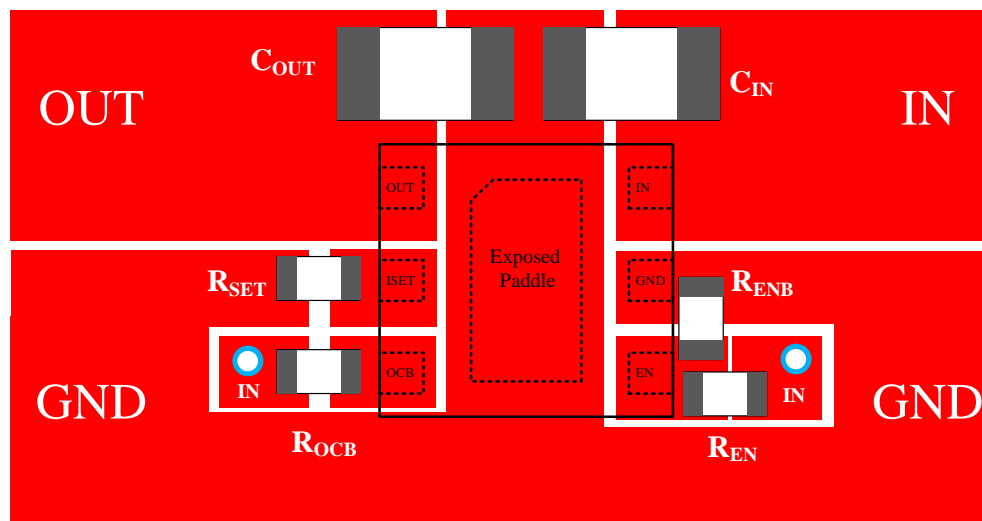
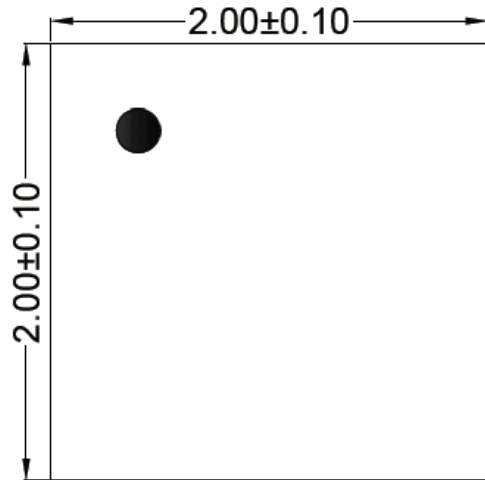
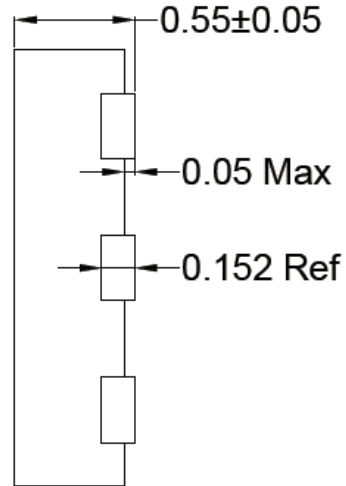

Figure3. PCB Layout Suggestion (SY86201EDED)

DFN2×2-6 Package Outline



Top View



Side View

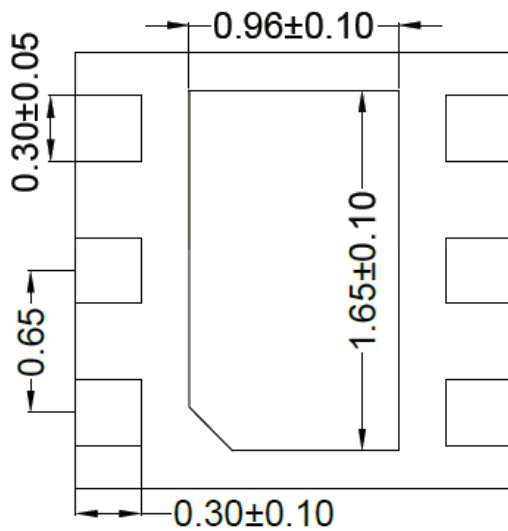

Bottom View

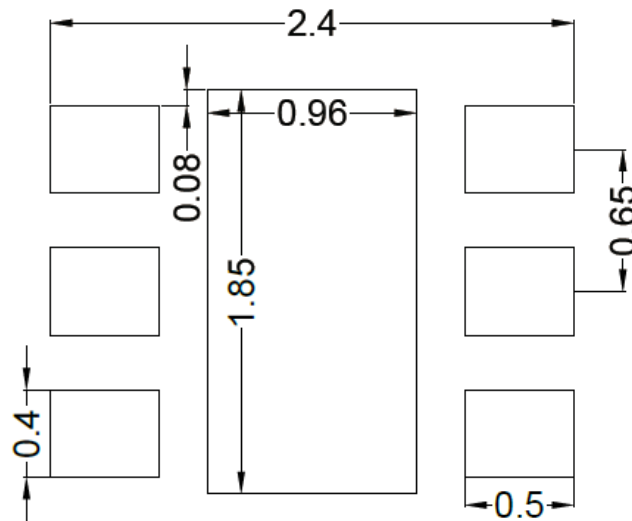

Recommended PCB layout

Notes: *All dimension in millimeter and exclude mold flash & metal burr*

SOT23-6 Package Outline & PCB Layout

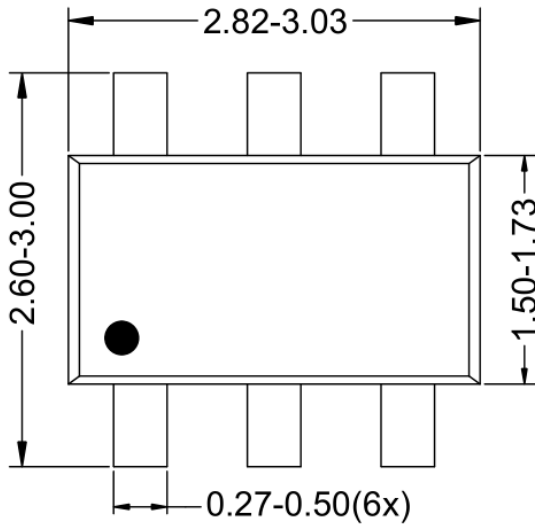

Top View

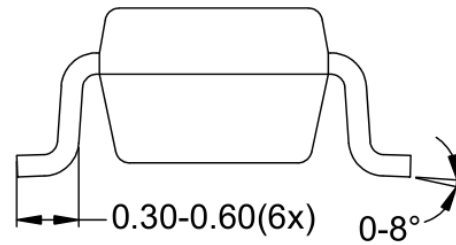

Side View

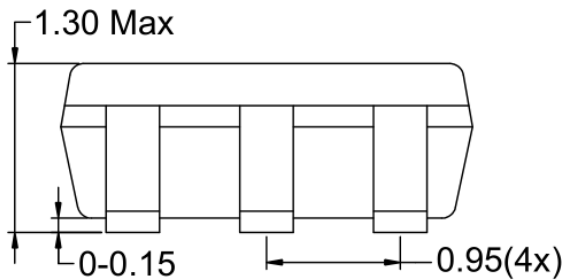

Side View

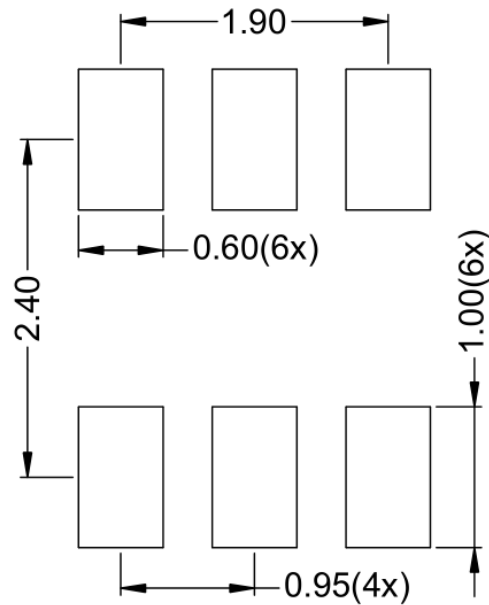

Recommended PCB Layout

Notes: All dimension in millimeter and exclude mold flash & metal burr.

Tape and Reel Information

1. Tape dimensions and pin 1 orientation

DFN2x2

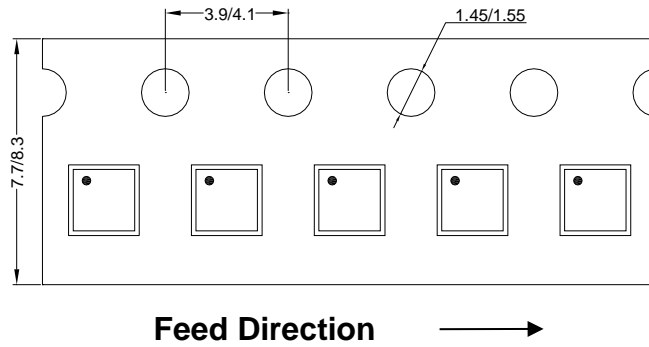

SOT23-6

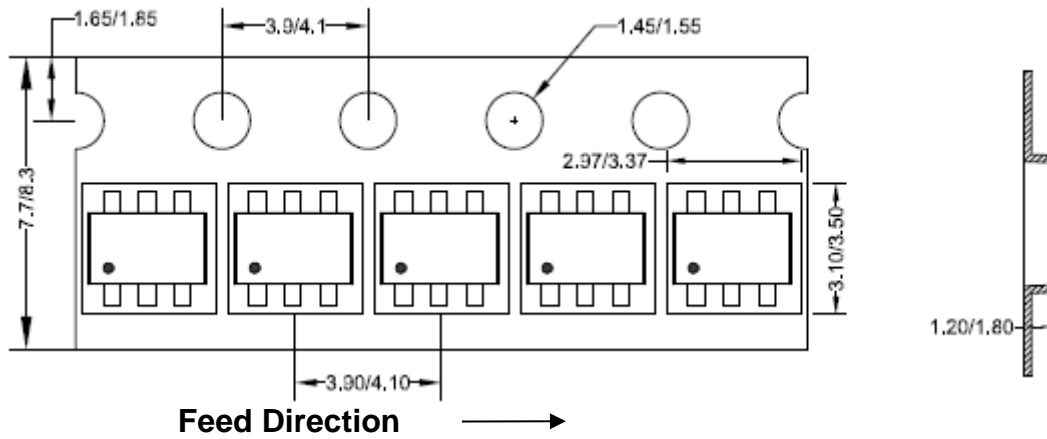

2. Reel dimensions

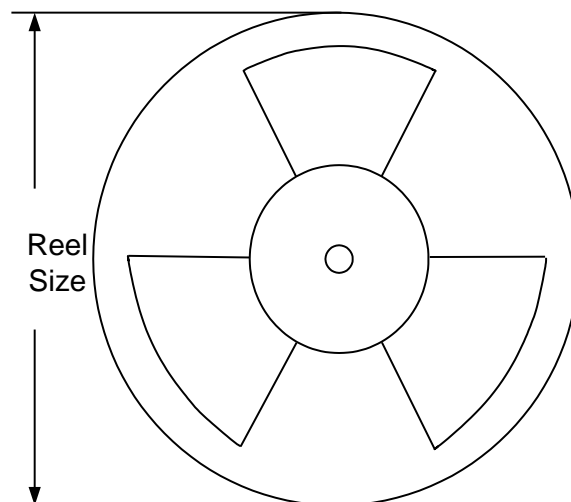



SY86201E

Package types	Tape width (mm)	Pocket pitch(mm)	Reel size (Inch)	Trailer length(mm)	Leader length (mm)	Qty per reel
DFN2x2	8	4	7"	400	160	3000
SOT23-6	8	4	7"	280	160	3000

Revision History

The revision history provided is for informational purpose only and is believed to be accurate, however, not warranted. Please make sure that you have the latest revision.

Date	Revision	Change
Feb. 28, 2025	Revision 1.0	Initial Release

IMPORTANT NOTICE

- 1. Right to make changes.** Silergy and its subsidiaries (hereafter Silergy) reserve the right to change any information published in this document, including but not limited to circuitry, specification and/or product design, manufacturing or descriptions, at any time and without notice. This document supersedes and replaces all information supplied prior to the publication hereof. Buyers should obtain the latest relevant information before placing orders and should verify that such information is current and complete. All semiconductor products are sold subject to Silergy's standard terms and conditions of sale.
- 2. Applications.** Application examples that are described herein for any of these products are for illustrative purposes only. Silergy makes no representation or warranty that such applications will be suitable for the specified use without further testing or modification. Buyers are responsible for the design and operation of their applications and products using Silergy products. Silergy or its subsidiaries assume no liability for any application assistance or designs of customer products. It is customer's sole responsibility to determine whether the Silergy product is suitable and fit for the customer's applications and products planned. To minimize the risks associated with customer's products and applications, customer should provide adequate design and operating safeguards. Customer represents and agrees that it has all the necessary expertise to create and implement safeguards which anticipate dangerous consequences of failures, monitor failures and their consequences, lessen the likelihood of failures that might cause harm and take appropriate remedial actions. Silergy assumes no liability related to any default, damage, costs or problem in the customer's applications or products, or the application or use by customer's third-party buyers. Customer will fully indemnify Silergy, its subsidiaries, and their representatives against any damages arising out of the use of any Silergy components in safety-critical applications. It is also buyers' sole responsibility to warrant and guarantee that any intellectual property rights of a third party are not infringed upon when integrating Silergy products into any application. Silergy assumes no responsibility for any said applications or for any use of any circuitry other than circuitry entirely embodied in a Silergy product.
- 3. Limited warranty and liability.** Information furnished by Silergy in this document is believed to be accurate and reliable. However, Silergy makes no representation or warranty, expressed or implied, as to the accuracy or completeness of such information and shall have no liability for the consequences of use of such information. In no event shall Silergy be liable for any indirect, incidental, punitive, special or consequential damages, including but not limited to lost profits, lost savings, business interruption, costs related to the removal or replacement of any products or rework charges, whether or not such damages are based on tort or negligence, warranty, breach of contract or any other legal theory. Notwithstanding any damages that customer might incur for any reason whatsoever, Silergy' aggregate and cumulative liability towards customer for the products described herein shall be limited in accordance with the Standard Terms and Conditions of Sale of Silergy.
- 4. Suitability for use.** Customer acknowledges and agrees that it is solely responsible for compliance with all legal, regulatory and safety-related requirements concerning its products, and any use of Silergy components in its applications, notwithstanding any applications-related information or support that may be provided by Silergy. Silergy products are not designed, authorized or warranted to be suitable for use in life support, life-critical or safety-critical systems or equipment, nor in applications where failure or malfunction of a Silergy product can reasonably be expected to result in personal injury, death or severe property or environmental damage. Silergy assumes no liability for inclusion and/or use of Silergy products in such equipment or applications and therefore such inclusion and/or use is at the customer's own risk.
- 5. Terms and conditions of commercial sale.** Silergy products are sold subject to the standard terms and conditions of commercial sale, as published at <http://www.silergy.com/stdterms>, unless otherwise agreed in a valid written individual agreement specifically agreed to in writing by an authorized officer of Silergy. In case an individual agreement is concluded only the terms and conditions of the respective agreement shall apply. Silergy hereby expressly objects to and denies the application of any customer's general terms and conditions with regard to the purchase of Silergy products by the customer.
- 6. No offer to sell or license.** Nothing in this document may be interpreted or construed as an offer to sell products that is open for acceptance or the grant, conveyance or implication of any license under any copyrights, patents or other industrial or intellectual property rights. Silergy makes no representation or warranty that any license, either express or implied, is granted under any patent right, copyright, mask work right, or other intellectual property right. Information published by Silergy regarding third-party products or services does not constitute a license to use such products or services or a warranty or endorsement thereof. Use of such information may require a license from a third party under the patents or other intellectual property of the third party, or a license from Silergy under the patents or other intellectual property of Silergy.

For more information, please visit: www.silergy.com

© 2025 Silergy Corp.

All Rights Reserved.