

# MOSFET – Power, N-Channel

50 V, 14 A, 100 mΩ

## RFD14N05SM9A

### Description

These are N-channel power MOSFETs manufactured using the MegaFET process. This process, which uses feature sizes approaching those of LSI integrated circuits, gives optimum utilization of silicon, resulting in outstanding performance. They were designed for use in applications such as switching regulators, switching converters, motor drivers and relay drivers. These transistors can be operated directly from integrated circuits.

Formerly developmental type TA09770.

### Features

- 14 A, 50 V
- $R_{DS(ON)} = 0.100 \Omega$
- Temperature Compensating PSpice® Model
- Peak Current vs Pulse Width Curve
- UIS Rating Curve
- 175°C Operating Temperature
- Related Literature
  - ◆ TB334 “Guidelines for Soldering Surface Mount Components to PC Boards”
- This is a Pb-Free Device

### ABSOLUTE MAXIMUM RATINGS (T<sub>C</sub> = 25°C, unless otherwise noted)

Parameter	Symbol	Ratings	Unit
Drain to Source Voltage (Note 1)	V <sub>DSS</sub>	50	V
Drain to Gate Voltage (R <sub>GS</sub> = 20 kΩ) (Note 1)	V <sub>DGR</sub>	50	V
Gate to Source Voltage	V <sub>GS</sub>	±20	V
Continuous Drain Current	I <sub>D</sub>	14	A
Pulsed Drain Current (Note 3)	I <sub>DM</sub>	Refer to Peak Current Curve	
Pulsed Avalanche Rating	E <sub>AS</sub>	Refer to UIS Curve	
Power Dissipation	P <sub>D</sub>	48	W
Derate above 25°C		0.32	W/°C
Operating and Storage Temperature	T <sub>J</sub> , T <sub>STG</sub>	-55 to 175	°C
Maximum Temperature for Soldering			
Leads at 0.063 in (1.6 mm) from Case for 10 s	T <sub>L</sub>	300	°C
Package Body for 10 s, See Techbrief 334	T <sub>pkg</sub>	260	°C

Stresses exceeding those listed in the Maximum Ratings table may damage the device. If any of these limits are exceeded, device functionality should not be assumed, damage may occur and reliability may be affected.

1. T<sub>J</sub> = 25°C to 150°C.

V <sub>DSS</sub>	R <sub>DS(ON)</sub> MAX	I <sub>D</sub> MAX
50 V	100 mΩ @ 10 V	14 A

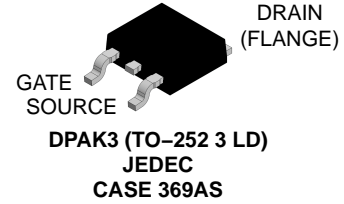

### MARKING DIAGRAM

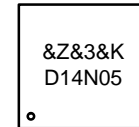

&Z = Assembly Plant Code  
&3 = 3-Digit Date Code  
&K = 2-Digits Lot Run Code  
D14N05 = Specific Device Code

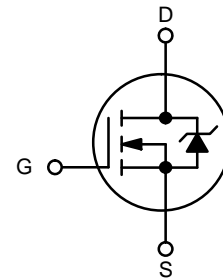

N-Channel MOSFET

### ORDERING INFORMATION

Device	Package	Shipping†
RFD14N05SM9A	DPAK3 (TO-252 3 LD) (Pb-Free)	2500 / Tape & Reel

†For information on tape and reel specifications, including part orientation and tape sizes, please refer to our Tape and Reel Packaging Specifications Brochure, BRD8011/D.

# RFD14N05SM9A

## ELECTRICAL SPECIFICATIONS (T<sub>C</sub> = 25°C, unless otherwise noted)

Parameter	Symbol	Test Conditions	Min	Typ	Max	Unit	
Drain to Source Breakdown Voltage	BV <sub>DSS</sub>	I <sub>D</sub> = 250 μA, V <sub>GS</sub> = 0 V (Figure 9)	50	–	–	V	
Gate Threshold Voltage	V <sub>GS(TH)</sub>	V <sub>GS</sub> = V <sub>DS</sub> , I <sub>D</sub> = 250 μA	2	–	4	V	
Zero Gate Voltage Drain Current	I <sub>DSS</sub>	V <sub>DS</sub> = Rated BV <sub>DSS</sub> , V <sub>GS</sub> = 0 V	–	–	25	μA	
		V <sub>DS</sub> = 0.8 × Rated BV <sub>DSS</sub> , V <sub>GS</sub> = 0 V, T <sub>C</sub> = 150°C	–	–	250	μA	
Gate to Source Leakage Current	I <sub>GSS</sub>	V <sub>GS</sub> = ±20 V	–	–	±100	nA	
Drain to Source On Resistance (Note 2)	R <sub>DS(ON)</sub>	I <sub>D</sub> = 14 A, V <sub>GS</sub> = 10 V, (Figure 11)	–	–	0.100	Ω	
Turn-On Time	t <sub>ON</sub>	V <sub>DD</sub> = 25 V, I <sub>D</sub> ≈ 14 A, V <sub>GS</sub> = 10 V, R <sub>GS</sub> = 25 Ω, R <sub>L</sub> = 1.7 Ω (Figure 13)	–	–	60	ns	
Turn-On Delay Time	t <sub>d(ON)</sub>		–	14	–	ns	
Rise Time	t <sub>r</sub>		–	26	–	ns	
Turn-Off Delay Time	t <sub>d(OFF)</sub>		–	45	–	ns	
Fall Time	t <sub>f</sub>		–	17	–	ns	
Turn-Off Time	t <sub>OFF</sub>		–	–	100	ns	
Total Gate Charge	Q <sub>g(TOT)</sub>	V <sub>GS</sub> = 0 V to 20 V	V <sub>DD</sub> = 40 V, I <sub>D</sub> = 14 A, R <sub>L</sub> = 2.86 Ω I <sub>g(REF)</sub> = 0.4 mA (Figure 13)	–	–	40	nC
Gate Charge at 5 V	Q <sub>g(10)</sub>	V <sub>GS</sub> = 0 V to 10 V		–	–	25	nC
Threshold Gate Charge	Q <sub>g(TH)</sub>	V <sub>GS</sub> = 0 V to 2 V		–	–	1.5	nC
Input Capacitance	C <sub>ISS</sub>	V <sub>DS</sub> = 25 V, V <sub>GS</sub> = 0 V, f = 1MHz (Figure 12)	–	570	–	pF	
Output Capacitance	C <sub>OSS</sub>		–	185	–	pF	
Reverse Transfer Capacitance	C <sub>RSS</sub>		–	50	–	pF	
Thermal Resistance Junction to Case	R <sub>θJC</sub>		–	–	3.125	°C/W	
Thermal Resistance Junction to Ambient	R <sub>θJA</sub>		–	–	100	°C/W	

Product parametric performance is indicated in the Electrical Characteristics for the listed test conditions, unless otherwise noted. Product performance may not be indicated by the Electrical Characteristics if operated under different conditions.

## SOURCE TO DRAIN DIODE SPECIFICATIONS

Parameter	Symbol	Test Conditions	Min	Typ	Max	Unit
Source to Drain Diode Voltage (Note 2)	V <sub>SD</sub>	I <sub>SD</sub> = 14 A	–	–	1.5	V
Diode Reverse Recovery Time	t <sub>rr</sub>	I <sub>SD</sub> = 14 A, dI <sub>SD</sub> /dt = 100 A/μs	–	–	125	ns

2. Pulse Test: Pulse Width ≤300 ms, Duty Cycle ≤2%.

3. Repetitive Rating: Pulse Width limited by max junction temperature. See Transient Thermal Impedance Curve (Figure 3) and Peak Current Capability Curve (Figure 5).

# RFD14N05SM9A

## TYPICAL PERFORMANCE CURVES

(UNLESS OTHERWISE NOTED)

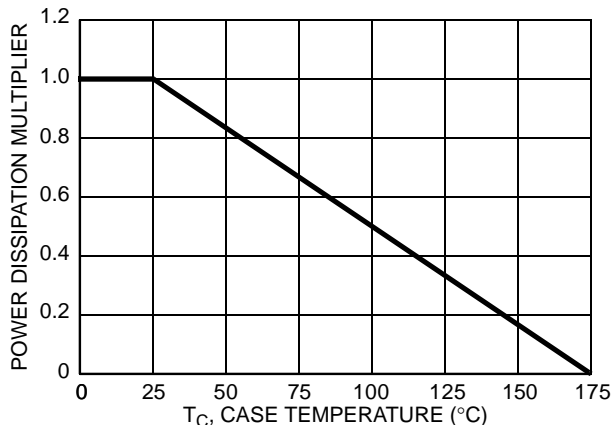

Figure 1. Normalized Power Dissipation vs. Case Temperature

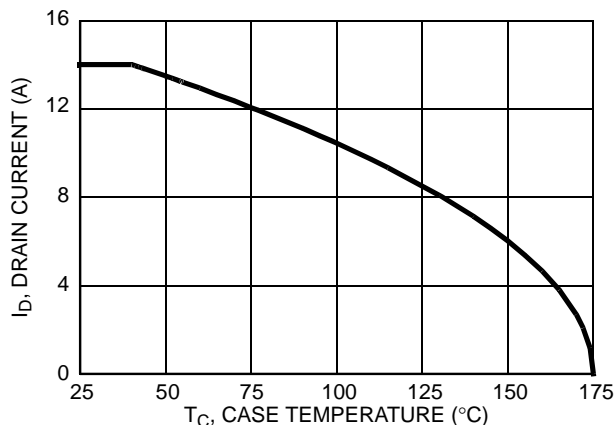

Figure 2. Maximum Continuous Drain Current vs. Case Temperature

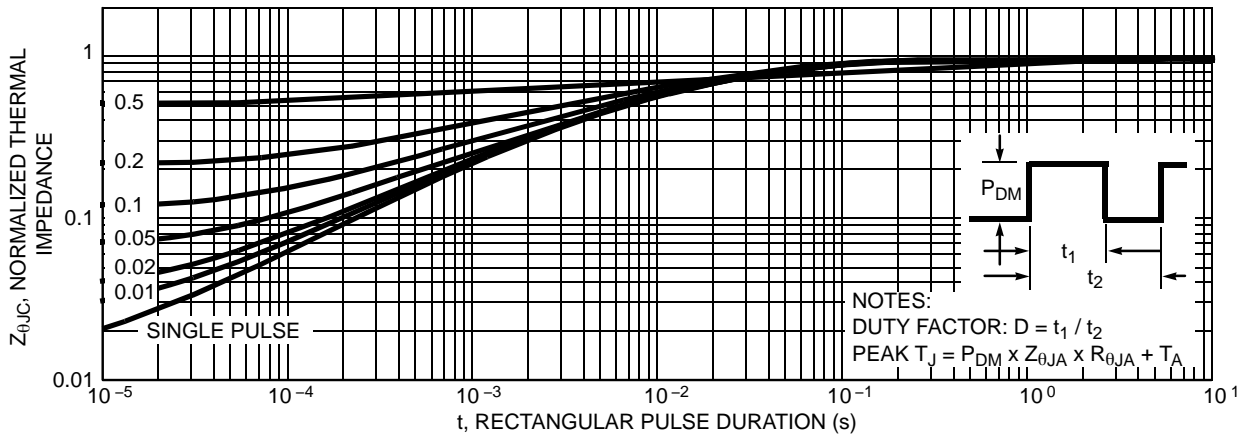

Figure 3. Normalized Maximum Transient Thermal Impedance

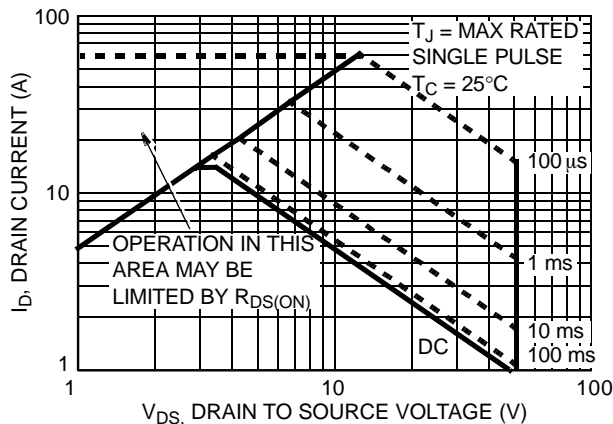

Figure 4. Forward Bias Safe Operating Area

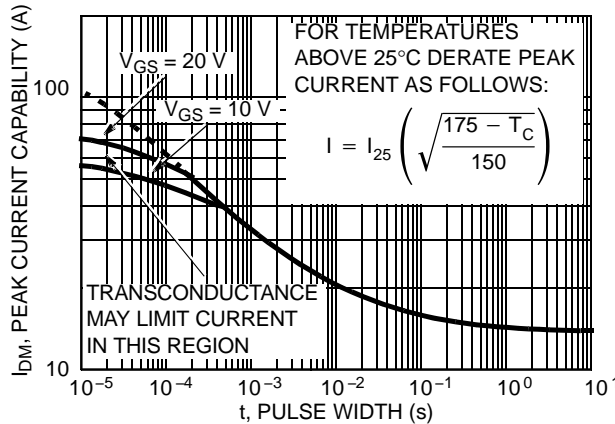
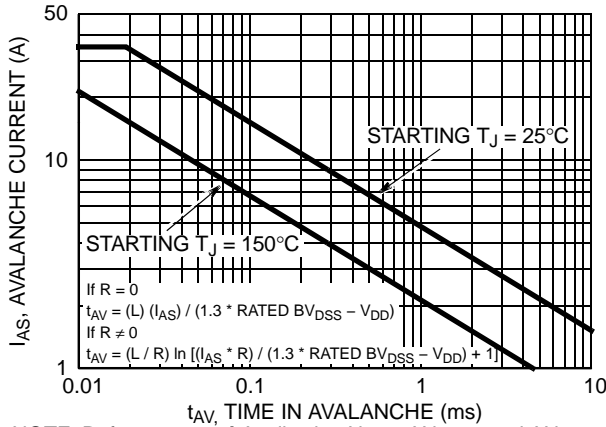

Figure 5. Peak Current Capability

# RFD14N05SM9A

## TYPICAL PERFORMANCE CURVES

(UNLESS OTHERWISE NOTED) (CONTINUED)



NOTE: Refer to **onsemi** Application Notes AN9321 and AN9322.

**Figure 6. Unclamped Inductive Switching**

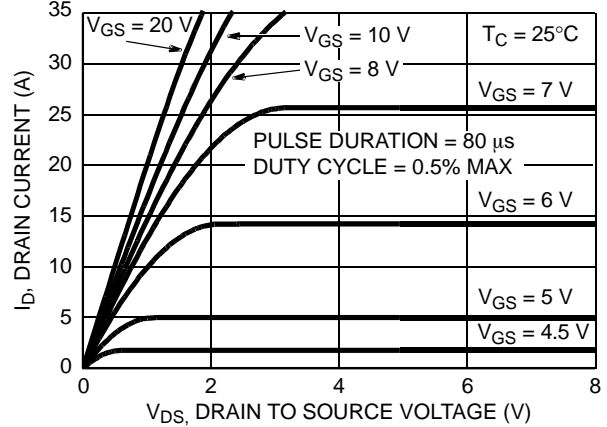

**Figure 7. Saturation Characteristics**

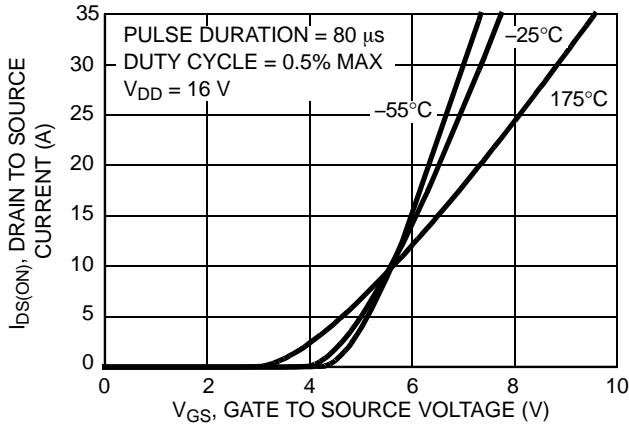

**Figure 8. Transfer Characteristics**

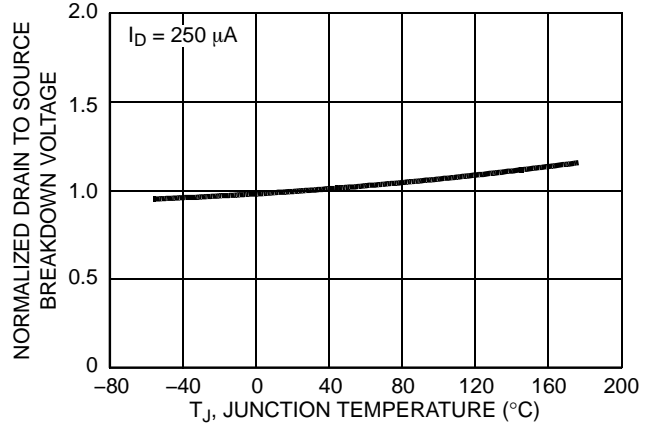

**Figure 9. Normalized Drain to Source Breakdown Voltage vs. Junction Temperature**

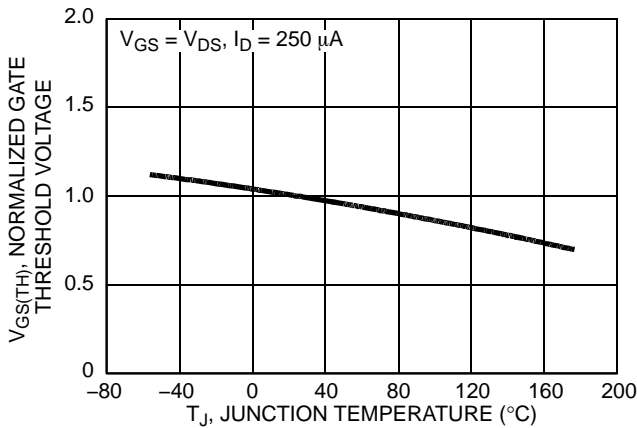

**Figure 10. Normalized Gate Threshold Voltage vs. Junction Temperature**

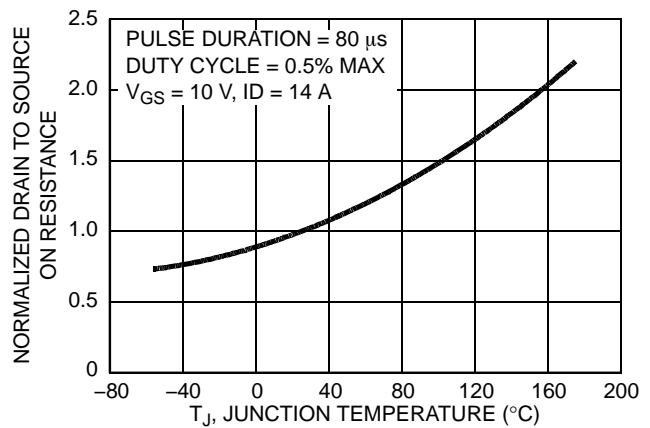

**Figure 11. Normalized Gate to Source On Resistance vs. Junction Temperature**

TYPICAL PERFORMANCE CURVES

(UNLESS OTHERWISE NOTED) (CONTINUED)

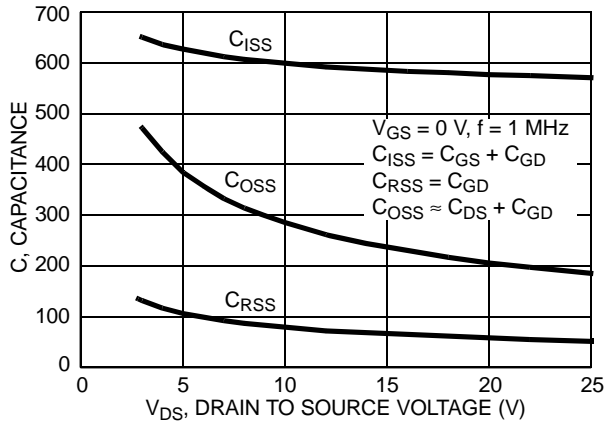
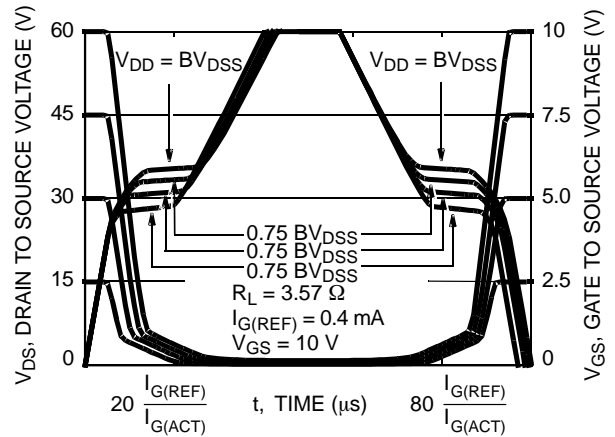

Figure 12. Capacitance vs. Drain to Source Voltage



NOTE: Refer to onsemi Application Notes AN7254 and AN7260.  
Figure 13. Normalized Switching Waveforms for Constant Current Gate Drive

TEST CIRCUITS AND WAVEFORMS

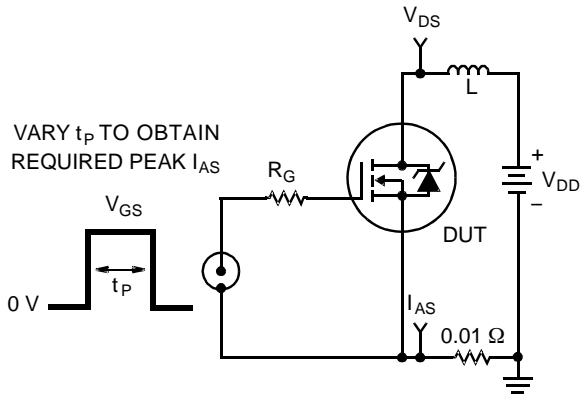

Figure 14. Unclamped Energy Test Circuit

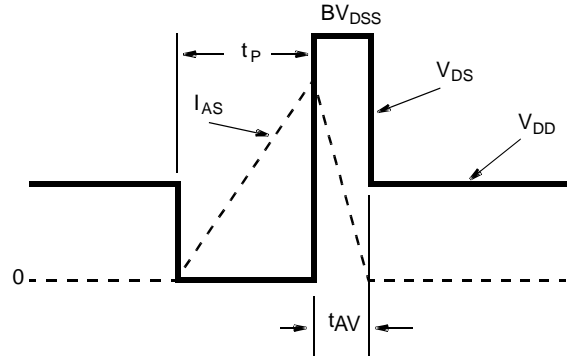

Figure 15. Unclamped Energy Waveforms

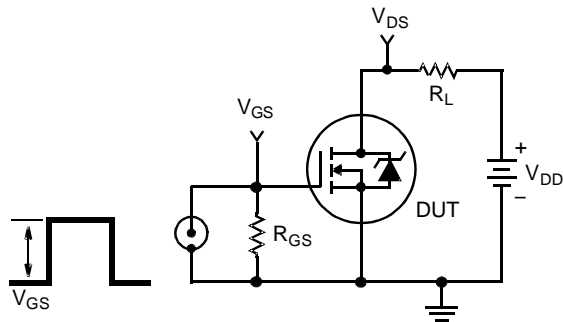

Figure 16. Switching Time Test Circuit

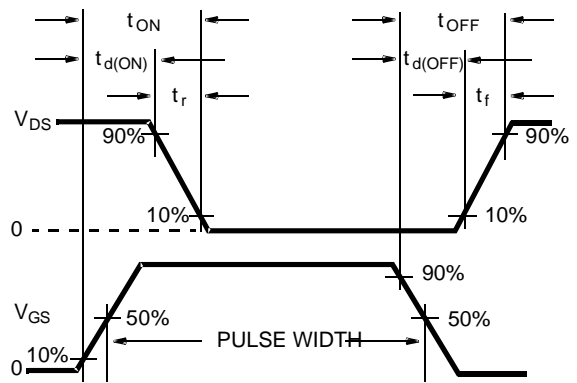

Figure 17. Resistive Switching Waveforms

# RFD14N05SM9A

## TEST CIRCUITS AND WAVEFORMS

(CONTINUED)

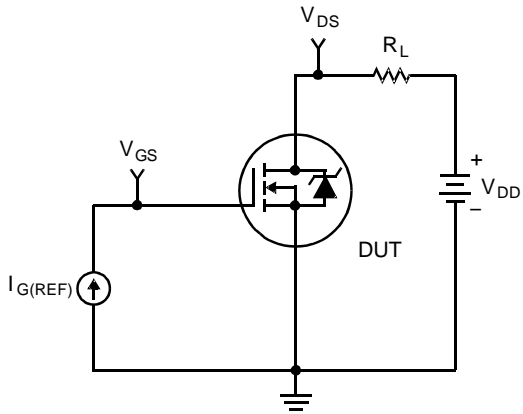

Figure 18. Gate Charge Test Circuit

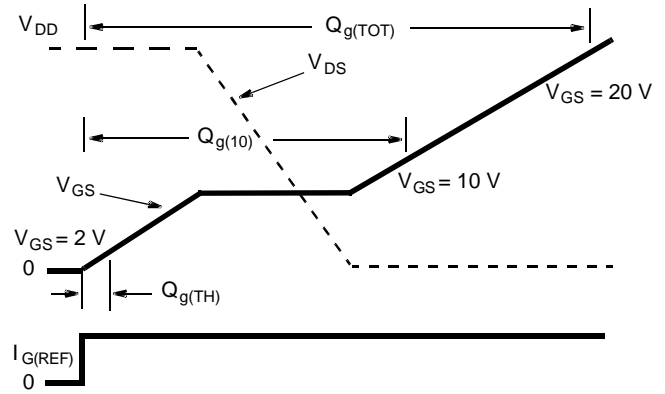

Figure 19. Gate Charge Waveforms

# RFD14N05SM9A

## PSPICE ELECTRICAL MODEL

```
.SUBCKT RFD14N05 2 1 3 ; rev 9/12/94

CA 12 8 8.84e-10
CB 15 14 9.34e-10
CIN 6 8 5.2e-10

DBODY 7 5 DBDMOD
DBREAK 5 11 DBKMOD
DPLCAP 10 5 DPLCAPMOD

EBREAK 11 7 17 18 62.87
EDS 14 8 5 8 1
EGS 13 8 6 8 1
ESG 6 10 6 8 1
EVTO 20 6 18 8 1

IT 8 17 1

LDRAIN 2 5 1e-9
LGATE 1 9 4.34e-9
LSOURCE 3 7 3.79e-9

MOS1 16 6 8 8 MOSMOD M = 0.99
MOS2 16 21 8 8 MOSMOD M = 0.01

RBREAK 17 18 RBKMOD 1
RDRAIN 50 16 RDSMOD 2.2e-3
RGATE 9 20 5.64
RIN 6 8 1e9
RSCL1 5 51 RSCLMOD 1e-6
RSCL2 5 50 1e3
RSOURCE 8 7 RDSMOD 42.3e-3
RVTO 18 19 RVTOMOD 1

S1A 6 12 13 8 S1AMOD
S1B 13 12 13 8 S1BMOD
S2A 6 15 14 13 S2AMOD
S2B 13 15 14 13 S2BMOD

VBAT 8 19 DC 1
VTO 21 6 0.82

ESCL 51 50 VALUE = {(V(5,51)/ABS(V(5,51)))*(PWR(V(5,51)*1e6/50,6))}

.MODEL DBDMOD D (IS = 1.5e-13 RS = 10.9e-3 TRS1 = 2.3e-3 TRS2 = -1.75e-5 CJO = 6.84e-10 TT = 4.2e-8)
.MODEL DBKMOD D (RS = 4.15e-1 TRS1 = 3.73e-3 TRS2 = -3.21e-5)
.MODEL DPLCAPMOD D (CJO = 26.2e-11 IS = 1e-30 N = 10)
.MODEL MOSMOD NMOS (VTO = 3.91 KP = 12.68 IS = 1e-30 N = 10 TOX = 1 L = 1u W = 1u)
.MODEL RBKMOD RES (TC1 = 7.73e-4 TC2 = 2.12e-6)
.MODEL RDSMOD RES (TC1 = 5.0e-3 TC2 = 2.53e-5)
.MODEL RSCLMOD RES (TC1 = 2.05e-3 TC2 = 1.35e-5)
.MODEL RVTOMOD RES (TC1 = -4.44e-3 TC2 = -6.45e-6)
.MODEL S1AMOD VSWITCH (RON = 1e-5 ROFF = 0.1 VON = -5.29 VOFF = -3.29)
.MODEL S1BMOD VSWITCH (RON = 1e-5 ROFF = 0.1 VON = -3.29 VOFF = -5.29)
.MODEL S2AMOD VSWITCH (RON = 1e-5 ROFF = 0.1 VON = -2.25 VOFF = 2.75)
```

## RFD14N05SM9A

.MODEL S2BMOD VSWITCH (RON = 1e-5 ROFF = 0.1 VON = 2.75 VOFF= -2.25)

.ENDS

NOTE: For further discussion of the PSPICE model, consult **A New PSPICE Sub-circuit for the Power MOSFET Featuring Global Temperature Options**; written by William J. Hepp and C. Frank Wheatley.

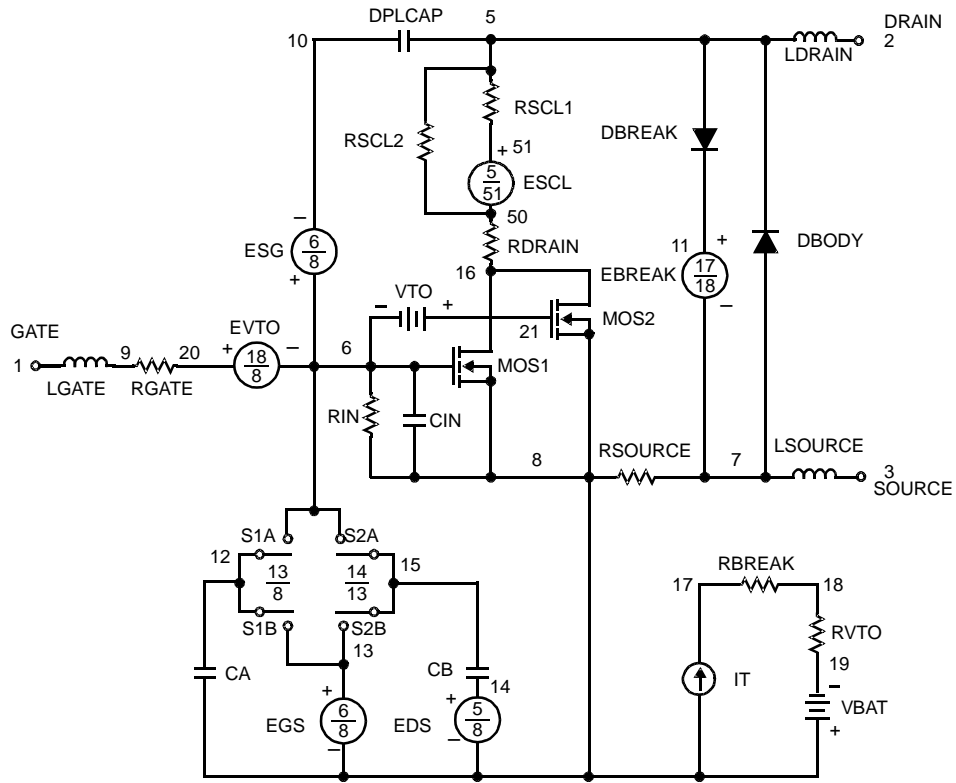
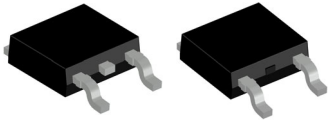
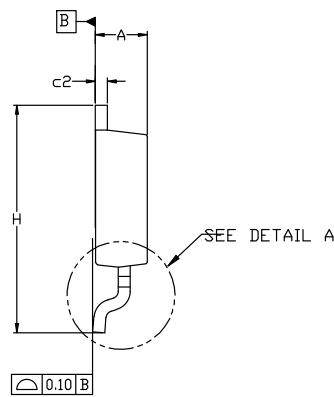
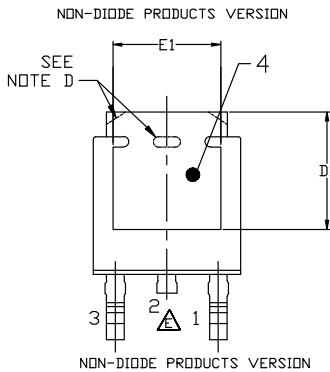
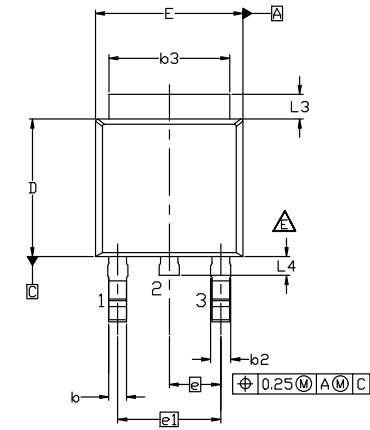

Figure 20. PSPICE Electrical Model



**DPAK3 6.10x6.54x2.29, 4.57P  
CASE 369AS  
ISSUE B**

DATE 20 DEC 2023



- NOTES: UNLESS OTHERWISE SPECIFIED  
 A) THIS PACKAGE CONFORMS TO JEDEC, TO-252, ISSUE F, VARIATION AA.  
 B) ALL DIMENSIONS ARE IN MILLIMETERS.  
 C) DIMENSIONING AND TOLERANCING PER ASME Y14.5M-2018.  
 D) SUPPLIER DEPENDENT MOLD LOCKING HOLES OR CHAMFERED CORNERS OR EDGE PROTRUSION.  
 E) FOR DIODE PRODUCTS, L4 IS 0.25 MM MAX PLASTIC BODY STUB WITHOUT CENTER LEAD.  
 F) DIMENSIONS ARE EXCLUSIVE OF BURRS, MOLD FLASH AND TIE BAR EXTRUSIONS.  
 G) LAND PATTERN RECOMMENDATION IS BASED ON IPC7351A STD TD228P991X239-3N.

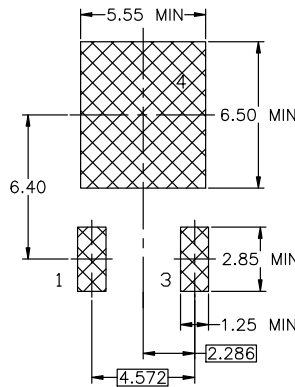
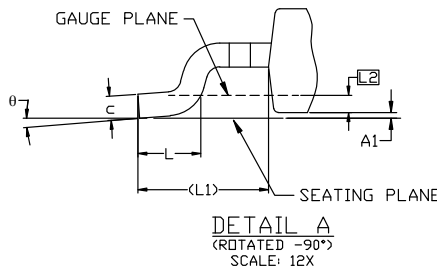

**LAND PATTERN RECOMMENDATION**

\*FOR ADDITIONAL INFORMATION ON OUR Pb-FREE STRATEGY AND SOLDERING DETAILS, PLEASE DOWNLOAD THE ON SEMICONDUCTOR SOLDERING AND MOUNTING TECHNIQUES REFERENCE MANUAL, SOLDERM/D.

DIM	MILLIMETERS		
	MIN.	NOM.	MAX.
A	2.18	2.29	2.39
A1	0.00	-	0.127
b	0.64	0.77	0.89
b2	0.76	0.95	1.14
b3	5.21	5.34	5.46
c	0.45	0.53	0.61
c2	0.45	0.52	0.58
D	5.97	6.10	6.22
D1	5.21	---	---
E	6.35	6.54	6.73
E1	4.32	---	---
e	2.286 BSC		
e1	4.572 BSC		
H	9.40	9.91	10.41
L	1.40	1.59	1.78
L1	2.90 REF		
L2	0.51 BSC		
L3	0.89	1.08	1.27
L4	---	---	1.02
θ	0°	---	10°

**GENERIC MARKING DIAGRAM\***

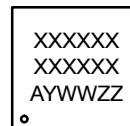

\*This information is generic. Please refer to device data sheet for actual part marking. Pb-Free indicator, "G" or microdot "•", may or may not be present. Some products may not follow the Generic Marking.

- XXXX = Specific Device Code
- A = Assembly Location
- Y = Year
- WW = Work Week
- ZZ = Assembly Lot Code

<b>DOCUMENT NUMBER:</b>	<b>98AON13810G</b>	Electronic versions are uncontrolled except when accessed directly from the Document Repository. Printed versions are uncontrolled except when stamped "CONTROLLED COPY" in red.
<b>DESCRIPTION:</b>	<b>DPAK3 6.10x6.54x2.29, 4.57P</b>	<b>PAGE 1 OF 1</b>

onsemi and Onsemi are trademarks of Semiconductor Components Industries, LLC dba onsemi or its subsidiaries in the United States and/or other countries. onsemi reserves the right to make changes without further notice to any products herein. onsemi makes no warranty, representation or guarantee regarding the suitability of its products for any particular purpose, nor does onsemi assume any liability arising out of the application or use of any product or circuit, and specifically disclaims any and all liability, including without limitation special, consequential or incidental damages. onsemi does not convey any license under its patent rights nor the rights of others.

**onsemi**, **Onsemi**, and other names, marks, and brands are registered and/or common law trademarks of Semiconductor Components Industries, LLC dba "**onsemi**" or its affiliates and/or subsidiaries in the United States and/or other countries. **onsemi** owns the rights to a number of patents, trademarks, copyrights, trade secrets, and other intellectual property. A listing of **onsemi**'s product/patent coverage may be accessed at [www.onsemi.com/site/pdf/Patent-Marking.pdf](http://www.onsemi.com/site/pdf/Patent-Marking.pdf). **onsemi** reserves the right to make changes at any time to any products or information herein, without notice. The information herein is provided "as-is" and **onsemi** makes no warranty, representation or guarantee regarding the accuracy of the information, product features, availability, functionality, or suitability of its products for any particular purpose, nor does **onsemi** assume any liability arising out of the application or use of any product or circuit, and specifically disclaims any and all liability, including without limitation special, consequential or incidental damages. Buyer is responsible for its products and applications using **onsemi** products, including compliance with all laws, regulations and safety requirements or standards, regardless of any support or applications information provided by **onsemi**. "Typical" parameters which may be provided in **onsemi** data sheets and/or specifications can and do vary in different applications and actual performance may vary over time. All operating parameters, including "Typicals" must be validated for each customer application by customer's technical experts. **onsemi** does not convey any license under any of its intellectual property rights nor the rights of others. **onsemi** products are not designed, intended, or authorized for use as a critical component in life support systems or any FDA Class 3 medical devices or medical devices with a same or similar classification in a foreign jurisdiction or any devices intended for implantation in the human body. Should Buyer purchase or use **onsemi** products for any such unintended or unauthorized application, Buyer shall indemnify and hold **onsemi** and its officers, employees, subsidiaries, affiliates, and distributors harmless against all claims, costs, damages, and expenses, and reasonable attorney fees arising out of, directly or indirectly, any claim of personal injury or death associated with such unintended or unauthorized use, even if such claim alleges that **onsemi** was negligent regarding the design or manufacture of the part. **onsemi** is an Equal Opportunity/Affirmative Action Employer. This literature is subject to all applicable copyright laws and is not for resale in any manner.

---

## ADDITIONAL INFORMATION

### TECHNICAL PUBLICATIONS:

Technical Library: [www.onsemi.com/design/resources/technical-documentation](http://www.onsemi.com/design/resources/technical-documentation)  
onsemi Website: [www.onsemi.com](http://www.onsemi.com)

### ONLINE SUPPORT: [www.onsemi.com/support](http://www.onsemi.com/support)

For additional information, please contact your local Sales Representative at [www.onsemi.com/support/sales](http://www.onsemi.com/support/sales)