



AiP74HC/HCT74

Dual D-type flip-flop with set and reset; positive-edge trigger

Product Specification

Specification Revision History:

Version	Date	Description
2012-05-A1	2012-05	New
2023-04-B1	2023-04	Update the template



1、 General Description

The AiP74HC/HCT74 are dual positive edge triggered D-type flip-flop. They have individual data (nD), clock (nCP), set (nSD) and reset (nRD) inputs, and complementary nQ and nQ outputs. Data at the nD-input, that meets the set-up and hold time requirements on the LOW-to-HIGH clock transition, is stored in the flip-flop and appears at the nQ output. Schmitt-trigger action in the clock input, makes the circuit highly tolerant to slower clock rise and fall times. Inputs include clamp diodes. This enables the use of current limiting resistors to interface inputs to voltages in excess of V_{CC} .

Features:

- Input levels:
For AiP74HC74: CMOS level
For AiP74HCT74: TTL level
- Symmetrical output impedance
- Low power dissipation
- Balanced propagation delays
- Specified from -40°C to +125°C
- Packaging information: DIP14/SOP14/TSSOP14

**Ordering Information:****Tube packing specifications:**

Part number	Packaging form	Marking code	Tube quantity	Boxed tube quantity	Boxed quantity	Notes
AiP74HC74DA14.TB	DIP14	74HC74	25 PCS/tube	40 tube/box	1000 PCS/box	Dimensions of plastic enclosure: 19.0mm×6.4mm Pin spacing: 2.54mm
AiP74HCT74DA14.TB	DIP14	74HCT74	25 PCS/tube	40 tube/box	1000 PCS/box	Dimensions of plastic enclosure: 19.0mm×6.4mm Pin spacing: 2.54mm
AiP74HC74SA14.TB	SOP14	74HC74	50 PCS/tube	200 tube/box	10000 PCS/box	Dimensions of plastic enclosure: 8.7mm×3.9mm Pin spacing: 1.27mm
AiP74HCT74SA14.TB	SOP14	74HCT74	50 PCS/tube	200 tube/box	10000 PCS/box	Dimensions of plastic enclosure: 8.7mm×3.9mm Pin spacing: 1.27mm
AiP74HC74TA14.TB	TSSOP14	74HC74	96 PCS/tube	200 tube/box	19200 PCS/box	Dimensions of plastic enclosure: 5.0mm×4.4mm Pin spacing: 0.65mm
AiP74HCT74TA14.TB	TSSOP14	74HCT74	96 PCS/tube	200 tube/box	19200 PCS/box	Dimensions of plastic enclosure: 5.0mm×4.4mm Pin spacing: 0.65mm

**Reel packing specifications:**

Part number	Packaging form	Marking code	Reel quantity	Boxed reel quantity	Notes
AiP74HC74SA14.TR	SOP14	74HC74	4000 PCS/reel	8000 PCS/box	Dimensions of plastic enclosure: 8.7mm×3.9mm Pin spacing: 1.27mm
AiP74HCT74SA14.TR	SOP14	74HCT74	4000 PCS/reel	8000 PCS/box	Dimensions of plastic enclosure: 8.7mm×3.9mm Pin spacing: 1.27mm
AiP74HC74TA14.TR	TSSOP14	74HC74	5000 PCS/reel	10000 PCS/box	Dimensions of plastic enclosure: 5.0mm×4.4mm Pin spacing: 0.65mm
AiP74HCT74TA14.TR	TSSOP14	74HCT74	5000 PCS/reel	10000 PCS/box	Dimensions of plastic enclosure: 5.0mm×4.4mm Pin spacing: 0.65mm

Note: If the physical information is inconsistent with the ordering information, please refer to the actual product.



2、Block Diagram And Pin Description

2.1、Block Diagram

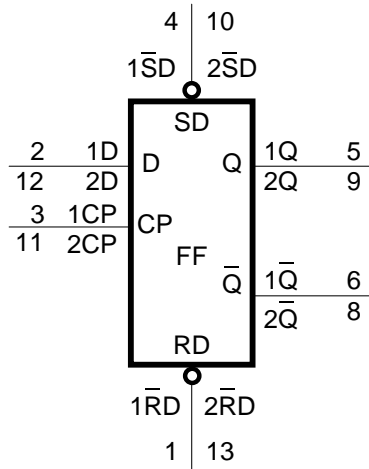

Figure 1. Logic symbol

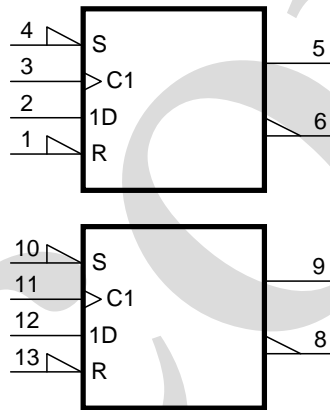

Figure 2. IEC logic symbol

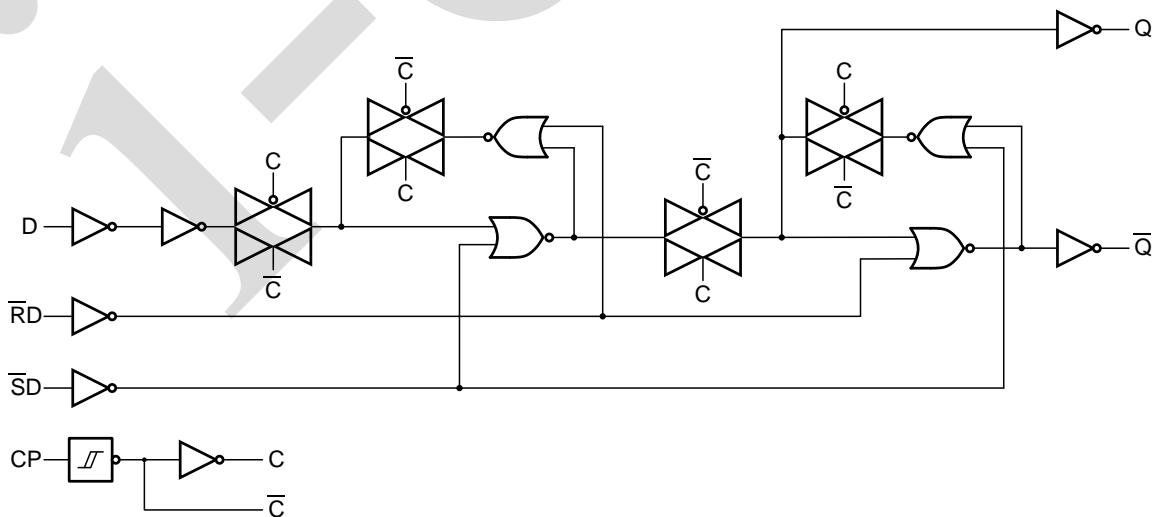

Figure 3. Logic diagram for one flip-flop

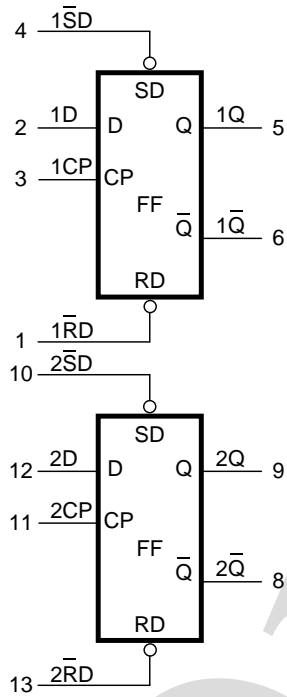
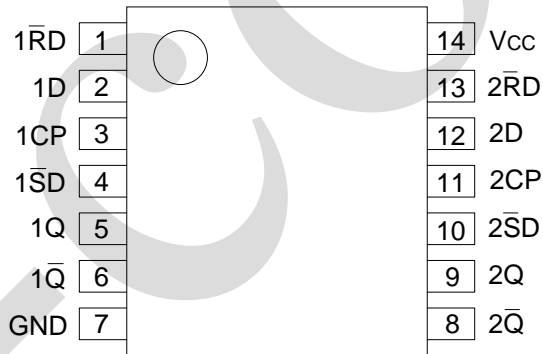

Figure 4. Functional diagram

2.2、Pin Configurations





2.3、Pin Description

Pin No.	Pin Name	Description
1	$\overline{1RD}$	asynchronous reset-direct input (active LOW)
2	1D	data input
3	1CP	clock input (LOW-to-HIGH, edge-triggered)
4	$\overline{1SD}$	asynchronous set-direct input (active LOW)
5	1Q	output
6	$\overline{1Q}$	complement output
7	GND	ground (0V)
8	$\overline{2Q}$	complement output
9	2Q	output
10	$\overline{2SD}$	asynchronous set-direct input (active LOW)
11	2CP	clock input (LOW-to-HIGH, edge-triggered)
12	2D	data input
13	$\overline{2RD}$	asynchronous reset-direct input (active LOW)
14	V _{CC}	supply voltage

2.4、Function Table

Input				Output	
\overline{nSD}	\overline{nRD}	nCP	nD	nQ	\overline{nQ}
L	H	X	X	H	L
H	L	X	X	L	H
L	L	X	X	H	H

Input				Output	
\overline{nSD}	\overline{nRD}	nCP	nD	nQ _{n+1}	\overline{nQ}_{n+1}
H	H	↑	L	L	H
H	H	↑	H	H	L

Note: H=HIGH voltage level; L=LOW voltage level; X=don't care;

↑=LOW-to-HIGH transition; Q_{n+1}=state after the next LOW-to-HIGH CP transition.



3、Electrical Parameter

3.1、Absolute Maximum Ratings

(Voltages are referenced to GND (ground=0V), unless otherwise specified.)

Parameter	Symbol	Conditions	Min.	Max.	Unit	
supply voltage	V_{CC}	-	-0.5	+7	V	
input clamping current	I_{IK}	$V_I < -0.5V$ or $V_I > V_{CC}+0.5V$	-	± 20	mA	
output clamping current	I_{OK}	$V_O < -0.5V$ or $V_O > V_{CC}+0.5V$	-	± 20	mA	
output current	I_O	$-0.5V < V_O < V_{CC}+0.5V$	-	± 25	mA	
supply current	I_{CC}	-	-	100	mA	
ground current	I_{GND}	-	-100	-	mA	
total power dissipation	P_{tot}	-	-	500	mW	
storage temperature	T_{stg}	-	-65	+150	$^{\circ}C$	
soldering temperature	T_L	10s	DIP		245	$^{\circ}C$
			SOP/TSSOP		260	

3.2、Recommended Operating Conditions

Parameter	Symbol	Conditions	Min.	Typ.	Max.	Unit
AiP74HC74						
supply voltage	V_{CC}	-	2.0	5.0	6.0	V
input voltage	V_I	-	0	-	V_{CC}	V
output voltage	V_O	-	0	-	V_{CC}	V
input transition rise and fall rate	$\Delta t/\Delta V$	$V_{CC}=2.0V$	-	-	625	ns/V
		$V_{CC}=4.5V$	-	1.67	139	ns/V
		$V_{CC}=6.0V$	-	-	83	ns/V
ambient temperature	T_{amb}	-	-40	-	+125	$^{\circ}C$
AiP74HCT74						
supply voltage	V_{CC}	-	4.5	5.0	5.5	V
input voltage	V_I	-	0	-	V_{CC}	V
output voltage	V_O	-	0	-	V_{CC}	V
input transition rise and fall rate	$\Delta t/\Delta V$	$V_{CC}=2.0V$	-	-	-	ns/V
		$V_{CC}=4.5V$	-	1.67	139	ns/V
		$V_{CC}=6.0V$	-	-	-	ns/V
ambient temperature	T_{amb}	-	-40	-	+125	$^{\circ}C$



3.3、Electrical Characteristics

3.3.1、DC Characteristics 1

($T_{amb} = -40^{\circ}\text{C}$ to $+85^{\circ}\text{C}$, voltages are referenced to GND (ground=0V), unless otherwise specified.)

Parameter	Symbol	Conditions		Min.	Typ.	Max.	Unit
AiP74HC74							
HIGH-level input voltage	V_{IH}	$V_{CC}=2.0\text{V}$		1.5	1.2	-	V
		$V_{CC}=4.5\text{V}$		3.15	2.4	-	V
		$V_{CC}=6.0\text{V}$		4.2	3.2	-	V
LOW-level input voltage	V_{IL}	$V_{CC}=2.0\text{V}$		-	0.8	0.5	V
		$V_{CC}=4.5\text{V}$		-	2.1	1.35	V
		$V_{CC}=6.0\text{V}$		-	2.8	1.8	V
HIGH-level output voltage	V_{OH}	$V_I=V_{IH}$ or V_{IL}	$I_O=-4.0\text{mA}; V_{CC}=4.5\text{V}$	3.84	4.32	-	V
			$I_O=-5.2\text{mA}; V_{CC}=6.0\text{V}$	5.34	5.81	-	V
LOW-level output voltage	V_{OL}	$V_I=V_{IH}$ or V_{IL}	$I_O=4.0\text{mA}; V_{CC}=4.5\text{V}$	-	0.15	0.33	V
			$I_O=5.2\text{mA}; V_{CC}=6.0\text{V}$	-	0.16	0.33	V
input leakage current	I_I	$V_I=V_{CC}$ or GND; $V_{CC}=6.0\text{V}$		-	-	± 1.0	μA
supply current	I_{CC}	$V_I=V_{CC}$ or GND; $I_O=0\text{A};$ $V_{CC}=6.0\text{V}$		-	-	40	μA
input capacitance	C_I	-		-	3.5	-	pF
AiP74HCT74							
HIGH-level input voltage	V_{IH}	$V_{CC}=4.5\text{V}$ to 5.5V		2.0	1.6	-	V
LOW-level input voltage	V_{IL}	$V_{CC}=4.5\text{V}$ to 5.5V		-	1.2	0.8	V
HIGH-level output voltage	V_{OH}	$V_I=V_{IH}$ or V_{IL}	$I_O=-4.0\text{mA}; V_{CC}=4.5\text{V}$	3.84	4.32	-	V
LOW-level output voltage	V_{OL}	$V_I=V_{IH}$ or V_{IL}	$I_O=5.2\text{mA}; V_{CC}=4.5\text{V}$	-	0.15	0.33	V
input leakage current	I_I	$V_I=V_{CC}$ or GND; $V_{CC}=5.5\text{V}$		-	-	± 1.0	μA
supply current	I_{CC}	$V_I=V_{CC}$ or GND; $I_O=0\text{A};$ $V_{CC}=5.5\text{V}$		-	-	40	μA
additional supply current	ΔI_{CC}	per input pin; $V_I=V_{CC}-2.1\text{V};$ $I_O=0\text{A};$ other inputs at V_{CC} or GND; $V_{CC}=4.5\text{V}$ to 5.5V	per input pin; nD, nRD inputs	-	-	315	μA
			per input pin; nSD, nCP input	-	-	360	μA
input capacitance	C_I	-		-	3.5	-	pF



3.3.2、DC Characteristics 2

($T_{amb} = -40^{\circ}\text{C}$ to $+125^{\circ}\text{C}$, voltages are referenced to GND (ground=0V), unless otherwise specified.)

Parameter	Symbol	Conditions	Min.	Typ.	Max.	Unit	
AiP74HC74							
HIGH-level input voltage	V_{IH}	$V_{CC}=2.0\text{V}$	1.5	-	-	V	
		$V_{CC}=4.5\text{V}$	3.15	-	-	V	
		$V_{CC}=6.0\text{V}$	4.2	-	-	V	
LOW-level input voltage	V_{IL}	$V_{CC}=2.0\text{V}$	-	-	0.5	V	
		$V_{CC}=4.5\text{V}$	-	-	1.35	V	
		$V_{CC}=6.0\text{V}$	-	-	1.8	V	
HIGH-level output voltage	V_{OH}	$V_I = V_{IH}$ or V_{IL}	$I_O = -4.0\text{mA}$; $V_{CC}=4.5\text{V}$	3.7	-	-	V
			$I_O = -5.2\text{mA}$; $V_{CC}=6.0\text{V}$	5.2	-	-	V
LOW-level output voltage	V_{OL}	$V_I = V_{IH}$ or V_{IL}	$I_O = 4.0\text{mA}$; $V_{CC}=4.5\text{V}$	-	-	0.4	V
			$I_O = 5.2\text{mA}$; $V_{CC}=6.0\text{V}$	-	-	0.4	V
input leakage current	I_I	$V_I = V_{CC}$ or GND; $V_{CC}=6.0\text{V}$	-	-	± 1.0	μA	
supply current	I_{CC}	$V_I = V_{CC}$ or GND; $I_O = 0\text{A}$; $V_{CC}=6.0\text{V}$	-	-	80	μA	
AiP74HCT74							
HIGH-level input voltage	V_{IH}	$V_{CC}=4.5\text{V}$ to 5.5V	2.0	-	-	V	
LOW-level input voltage	V_{IL}	$V_{CC}=4.5\text{V}$ to 5.5V	-	-	0.8	V	
HIGH-level output voltage	V_{OH}	$V_I = V_{IH}$ or V_{IL}	$I_O = -4.0\text{mA}$; $V_{CC}=4.5\text{V}$	3.7	-	-	V
LOW-level output voltage	V_{OL}	$V_I = V_{IH}$ or V_{IL}	$I_O = 5.2\text{mA}$; $V_{CC}=4.5\text{V}$	-	-	0.4	V
input leakage current	I_I	$V_I = V_{CC}$ or GND; $V_{CC}=5.5\text{V}$	-	-	± 1.0	μA	
supply current	I_{CC}	$V_I = V_{CC}$ or GND; $I_O = 0\text{A}$; $V_{CC}=5.5\text{V}$	-	-	80	μA	
additional supply current	ΔI_{CC}	per input pin; $V_I = V_{CC} - 2.1\text{V}$; $I_O = 0\text{A}$; other inputs at V_{CC} or GND; $V_{CC}=4.5\text{V}$ to 5.5V	per input pin; nD, nRD inputs	-	-	343	μA
			per input pin; nSD, nCP input	-	-	392	μA



3.3.3、AC Characteristics 1

($T_{amb} = -40^{\circ}\text{C}$ to $+85^{\circ}\text{C}$, voltages are referenced to GND (ground=0V), unless otherwise specified.)

Parameter	Symbol	Conditions	Min.	Typ.	Max.	Unit	
AiP74HC74							
nCP to nQ, n \bar{Q} propagation delay	t_{pd}	see Figure 6 ^[1]	$V_{CC}=2.0\text{V}$	-	47	220	ns
			$V_{CC}=4.5\text{V}$	-	17	44	ns
			$V_{CC}=5.0\text{V}; C_L=15\text{pF}$	-	14	-	ns
			$V_{CC}=6.0\text{V}$	-	14	37	ns
n $\bar{S}D$ to nQ, n \bar{Q} propagation delay	t_{pd}	see Figure 7 ^[1]	$V_{CC}=2.0\text{V}$	-	50	250	ns
			$V_{CC}=4.5\text{V}$	-	18	50	ns
			$V_{CC}=5.0\text{V}; C_L=15\text{pF}$	-	15	-	ns
			$V_{CC}=6.0\text{V}$	-	14	43	ns
n $\bar{R}D$ to nQ, n \bar{Q} propagation delay	t_{pd}	see Figure 7 ^[1]	$V_{CC}=2.0\text{V}$	-	52	250	ns
			$V_{CC}=4.5\text{V}$	-	19	50	ns
			$V_{CC}=5.0\text{V}; C_L=15\text{pF}$	-	16	-	ns
			$V_{CC}=6.0\text{V}$	-	15	43	ns
nQ, n \bar{Q} transition time	t_t	see Figure 6 ^[2]	$V_{CC}=2.0\text{V}$	-	19	95	ns
			$V_{CC}=4.5\text{V}$	-	7	19	ns
			$V_{CC}=6.0\text{V}$	-	6	16	ns
CP pulse width	t_w	see Figure 6	$V_{CC}=2.0\text{V}$	100	19	-	ns
			$V_{CC}=4.5\text{V}$	20	7	-	ns
			$V_{CC}=6.0\text{V}$	17	6	-	ns
n $\bar{S}D$, n $\bar{R}D$ pulse width	t_w	see Figure 7	$V_{CC}=2.0\text{V}$	100	19	-	ns
			$V_{CC}=4.5\text{V}$	20	7	-	ns
			$V_{CC}=6.0\text{V}$	17	6	-	ns
n $\bar{S}D$, n $\bar{R}D$ recovery time	t_{rec}	see Figure 7	$V_{CC}=2.0\text{V}$	40	3	-	ns
			$V_{CC}=4.5\text{V}$	8	1	-	ns
			$V_{CC}=6.0\text{V}$	7	1	-	ns
nD to nCP set-up time	t_{su}	see Figure 6	$V_{CC}=2.0\text{V}$	75	6	-	ns
			$V_{CC}=4.5\text{V}$	15	2	-	ns
			$V_{CC}=6.0\text{V}$	13	2	-	ns
nD to nCP hold time	t_h	see Figure 6	$V_{CC}=2.0\text{V}$	3	-6	-	ns
			$V_{CC}=4.5\text{V}$	3	-2	-	ns
			$V_{CC}=6.0\text{V}$	3	-2	-	ns
nCP maximum frequency	f_{max}	see Figure 6	$V_{CC}=2.0\text{V}$	4.8	23	-	MHz
			$V_{CC}=4.5\text{V}$	24	69	-	MHz
			$V_{CC}=5.0\text{V}; C_L=15\text{pF}$	-	76	-	MHz
			$V_{CC}=6.0\text{V}$	28	82	-	MHz
power dissipation capacitance	C_{PD}	$C_L=50\text{pF}; f=1\text{MHz}; V_I = \text{GND to } V_{CC}^{[3]}$	-	24	-	pF	
AiP74HCT74							
nCP to nQ, n \bar{Q} propagation delay	t_{pd}	see Figure 6 ^[1]	$V_{CC}=4.5\text{V}$	-	18	44	ns
			$V_{CC}=5.0\text{V}; C_L=15\text{pF}$	-	15	-	ns



nSD to nQ, nQ propagation delay	t _{pd}	see Figure 7 ^[1]	V _{CC} =4.5V	-	23	50	ns
			V _{CC} =5.0V; C _L =15pF	-	18	-	ns
nRD to nQ, nQ propagation delay	t _{pd}	see Figure 7 ^[1]	V _{CC} =4.5V	-	24	50	ns
			V _{CC} =5.0V; C _L =15pF	-	18	-	ns
nQ, nQ transition time	t _t	see Figure 6 ^[2]	V _{CC} =4.5V	-	7	19	ns
CP pulse width	t _w	see Figure 6	V _{CC} =4.5V	23	9	-	ns
nSD, nRD pulse width	t _w	see Figure 7	V _{CC} =4.5V	20	9	-	ns
nSD, nRD recovery time	t _{rec}	see Figure 7	V _{CC} =4.5V	8	1	-	ns
nD to nCP set-up time	t _{su}	see Figure 6	V _{CC} =4.5V	15	5	-	ns
nD to nCP hold time	t _h	see Figure 6	V _{CC} =4.5V	3	-3	-	ns
CP maximum frequency	f _{max}	see Figure 6	V _{CC} =4.5V	22	54	-	MHz
			V _{CC} =5.0V; C _L =15pF	-	59	-	MHz
power dissipation capacitance	C _{PD}	C _L =50pF; f=1 MHz; V _I = GND to V _{CC} -1.5V ^[3]		-	29	-	pF

Note:

[1] t_{pd} is the same as t_{PLH} and t_{PHL}.

[2] t_t is the same as t_{THL} and t_{TLH}.

[3] C_{PD} is used to determine the dynamic power dissipation (P_D in uW).

$$P_D = (C_{PD} \times V_{CC}^2 \times f_i \times N) + \sum (C_L \times V_{CC}^2 \times f_o) \text{ where:}$$

f_i=input frequency in MHz;

f_o=output frequency in MHz;

C_L=output load capacitance in pF;

V_{CC}=supply voltage in V;

N=number of inputs switching;

$\sum (C_L \times V_{CC}^2 \times f_o)$ =sum of outputs.



3.3.4、AC Characteristics 2

($T_{amb} = -40^{\circ}\text{C}$ to $+125^{\circ}\text{C}$, voltages are referenced to GND (ground=0V), unless otherwise specified.)

Parameter	Symbol	Conditions	Min.	Typ.	Max.	Unit	
AiP74HC74							
nCP to nQ, n \bar{Q} propagation delay	t_{pd}	see Figure 6 ^[1]	$V_{CC}=2.0\text{V}$	-	-	265	ns
			$V_{CC}=4.5\text{V}$	-	-	53	ns
			$V_{CC}=6.0\text{V}$	-	-	45	ns
n $\bar{S}D$ to nQ, n \bar{Q} propagation delay	t_{pd}	see Figure 7 ^[1]	$V_{CC}=2.0\text{V}$	-	-	300	ns
			$V_{CC}=4.5\text{V}$	-	-	60	ns
			$V_{CC}=6.0\text{V}$	-	-	51	ns
n $\bar{R}D$ to nQ, n \bar{Q} propagation delay	t_{pd}	see Figure 7 ^[1]	$V_{CC}=2.0\text{V}$	-	-	300	ns
			$V_{CC}=4.5\text{V}$	-	-	60	ns
			$V_{CC}=6.0\text{V}$	-	-	51	ns
nQ, n \bar{Q} transition time	t_t	see Figure 6 ^[2]	$V_{CC}=2.0\text{V}$	-	-	110	ns
			$V_{CC}=4.5\text{V}$	-	-	22	ns
			$V_{CC}=6.0\text{V}$	-	-	19	ns
CP pulse width	t_w	see Figure 6	$V_{CC}=2.0\text{V}$	120	-	-	ns
			$V_{CC}=4.5\text{V}$	24	-	-	ns
			$V_{CC}=6.0\text{V}$	20	-	-	ns
n $\bar{S}D$, n $\bar{R}D$ pulse width	t_w	see Figure 7	$V_{CC}=2.0\text{V}$	120	-	-	ns
			$V_{CC}=4.5\text{V}$	24	-	-	ns
			$V_{CC}=6.0\text{V}$	20	-	-	ns
n $\bar{S}D$, n $\bar{R}D$ recovery time	t_{rec}	see Figure 7	$V_{CC}=2.0\text{V}$	45	-	-	ns
			$V_{CC}=4.5\text{V}$	9	-	-	ns
			$V_{CC}=6.0\text{V}$	8	-	-	ns
nD to nCP set-up time	t_{su}	see Figure 6	$V_{CC}=2.0\text{V}$	90	-	-	ns
			$V_{CC}=4.5\text{V}$	18	-	-	ns
			$V_{CC}=6.0\text{V}$	15	-	-	ns
nD to nCP hold time	t_h	see Figure 6	$V_{CC}=2.0\text{V}$	3	-	-	ns
			$V_{CC}=4.5\text{V}$	3	-	-	ns
			$V_{CC}=6.0\text{V}$	3	-	-	ns
nCP maximum frequency	f_{max}	see Figure 6	$V_{CC}=2.0\text{V}$	4.0	-	-	MHz
			$V_{CC}=4.5\text{V}$	20	-	-	MHz
			$V_{CC}=6.0\text{V}$	24	-	-	MHz
AiP74HCT74							
nCP to nQ, n \bar{Q} propagation delay	t_{pd}	see Figure 6 ^[1]	$V_{CC}=4.5\text{V}$	-	-	53	ns
n $\bar{S}D$ to nQ, n \bar{Q} propagation delay	t_{pd}	see Figure 7 ^[1]	$V_{CC}=4.5\text{V}$	-	-	60	ns
n $\bar{R}D$ to nQ, n \bar{Q} propagation delay	t_{pd}	see Figure 7 ^[1]	$V_{CC}=4.5\text{V}$	-	-	60	ns
nQ, n \bar{Q} transition time	t_t	see Figure 6 ^[2]	$V_{CC}=4.5\text{V}$	-	-	22	ns



CP pulse width	t_w	see Figure 6	$V_{CC}=4.5V$	27	-	-	ns
\overline{nSD} , \overline{nRD} pulse width	t_w	see Figure 7	$V_{CC}=4.5V$	24	-	-	ns
\overline{nSD} , \overline{nRD} recovery time	t_{rec}	see Figure 7	$V_{CC}=4.5V$	9	-	-	ns
nD to nCP set-up time	t_{su}	see Figure 6	$V_{CC}=4.5V$	18	-	-	ns
nD to nCP hold time	t_h	see Figure 6	$V_{CC}=4.5V$	3	-	-	ns
CP maximum frequency	f_{max}	see Figure 6	$V_{CC}=4.5V$	18	-	-	MHz

Note:

[1] t_{pd} is the same as t_{PLH} and t_{PHL} .

[2] t_t is the same as t_{THL} and t_{TLH} .

4、Testing Circuit

4.1、AC Testing Circuit

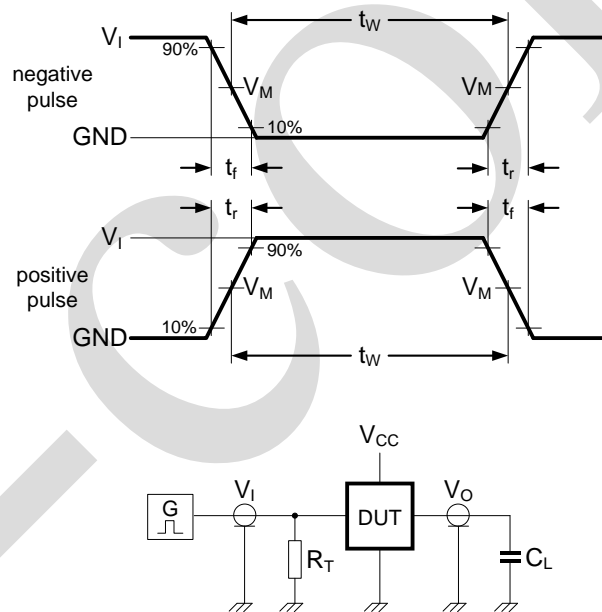

Figure 5. Test circuit for measuring switching times

Definitions for test circuit:

C_L =load capacitance including jig and probe capacitance.

R_T =termination resistance should be equal to the output impedance Z_o of the pulse generator.



4.2、AC Testing Waveforms

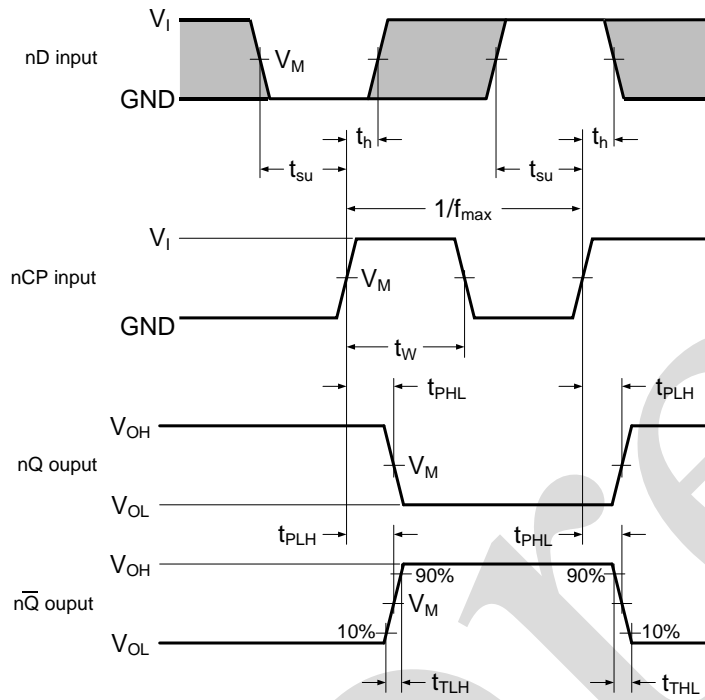

Figure 6. Input to output propagation delays

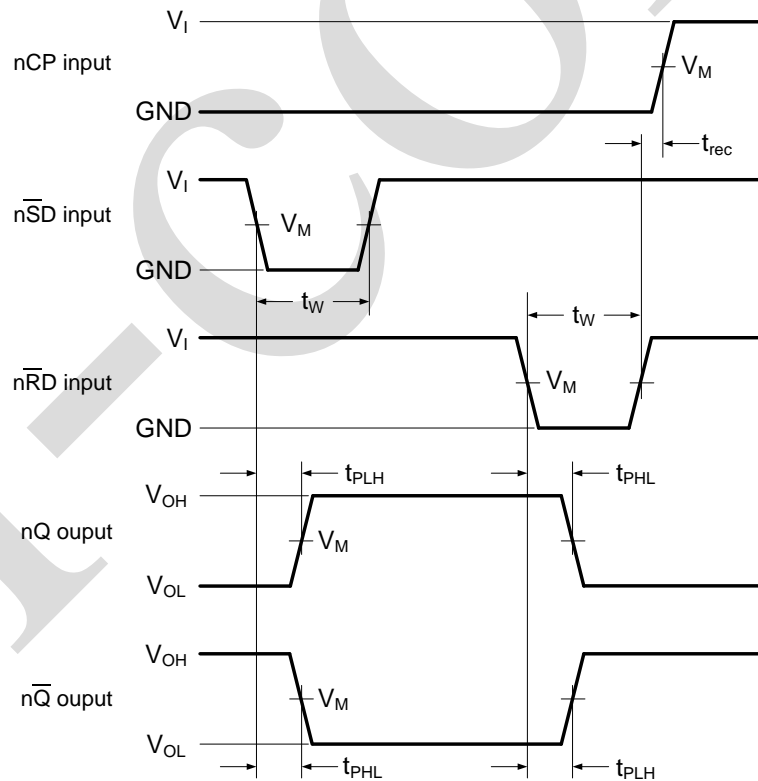

Figure 7. Set and reset propagation delays, pulse widths and recovery time



4.3、Measurement Points

Type	Input	Output
	V_M	V_M
AiP74HC74	$0.5 \times V_{CC}$	$0.5 \times V_{CC}$
AiP74HCT74	1.3V	1.3V

4.4、Test Data

Type	Input		Load		Test
	V_I	t_r, t_f	C_L	R_L	
AiP74HC74	V_{CC}	6.0ns	15pF, 50pF	1k Ω	t_{PLH}, t_{PHL}
AiP74HCT74	3.0V	6.0ns	15pF, 50pF	1k Ω	t_{PLH}, t_{PHL}



5、Package Information

5.1、DIP14

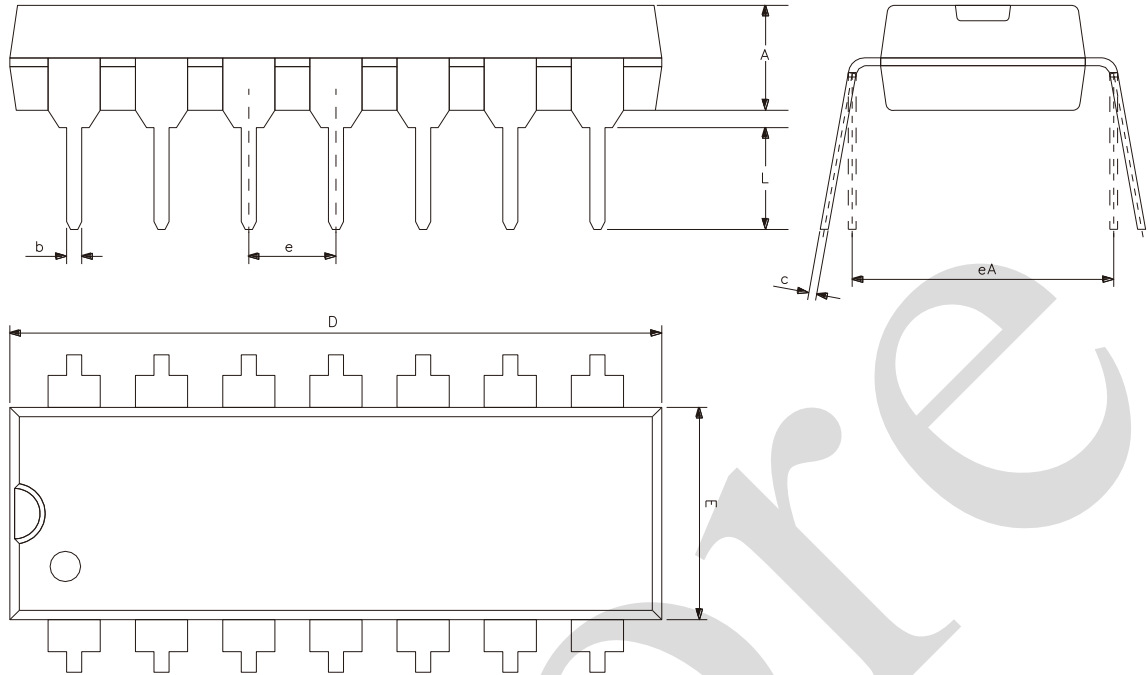

Symbol	Dimensions (mm)	
	Min.	Max.
A	3.05	3.60
b	0.33	0.56
c	0.20	0.36
D	18.80	19.40
E	6.20	6.60
e	2.54	
eA	7.62	10.90
L	2.92	-



5.2、SOP14

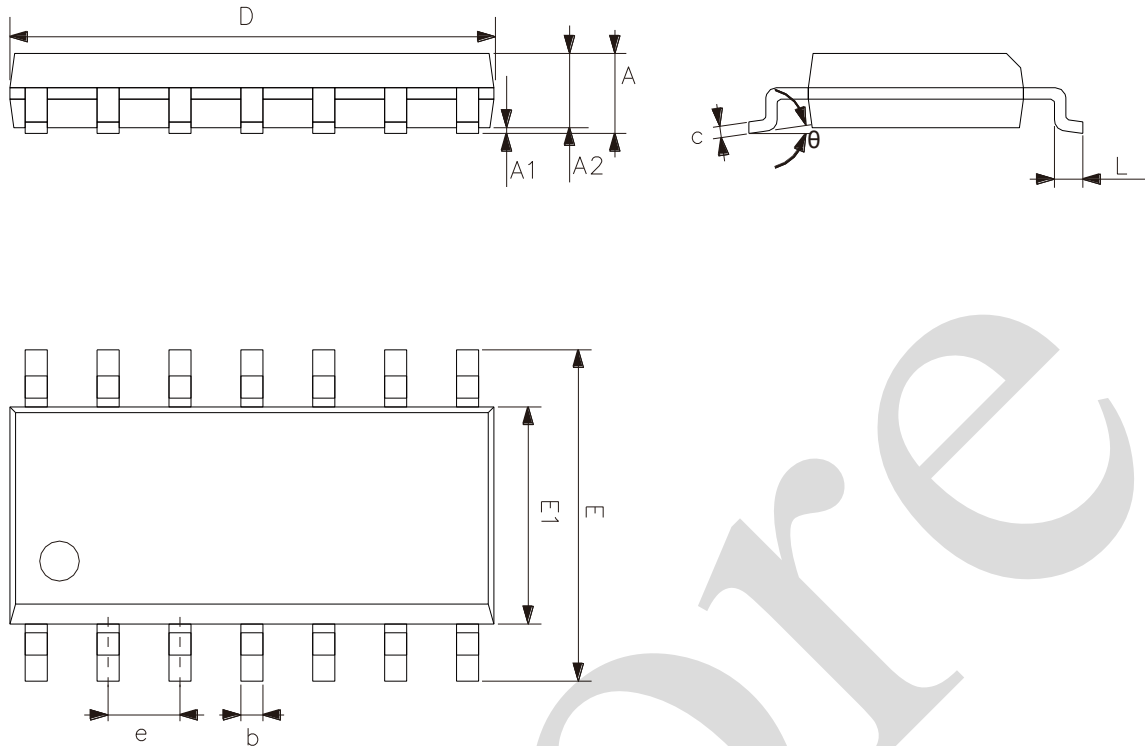

Symbol	Dimensions (mm)	
	Min.	Max.
A	1.50	1.75
A1	0.05	0.25
A2	1.30	-
b	0.33	0.50
c	0.19	0.25
D	8.43	8.76
E	5.80	6.25
E1	3.75	4.00
e	1.27	
L	0.40	0.89
θ	0°	8°



5.3、TSSOP14

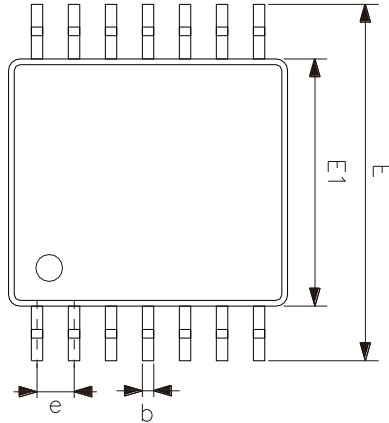
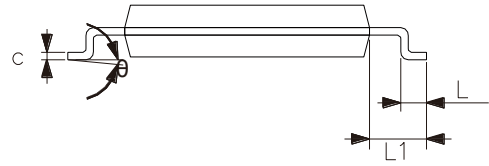
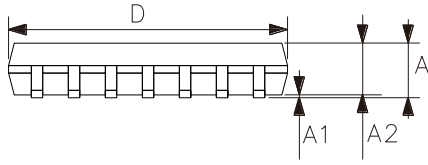

Symbol	Dimensions (mm)	
	Min.	Max.
A	-	1.20
A1	0.05	0.15
A2	0.80	1.05
b	0.19	0.30
c	0.09	0.20
D	4.90	5.10
E1	4.30	4.50
E	6.20	6.60
e	0.65	
L	0.45	0.75
L1	1.00	
θ	0°	8°



6、 Statements And Notes

6.1、 The name and content of Hazardous substances or Elements in the product

Part name	Hazardous substances or Elements									
	Lead and lead compounds	Mercury and mercury compounds	Cadmium and cadmium compounds	Hexavalent chromium compounds	Polybrominated biphenyls	Polybrominated biphenyl ethers	Dibutyl phthalate	Butylbenzyl phthalate	Di-2-ethylhexyl phthalate	Diisobutyl phthalate
Lead frame	○	○	○	○	○	○	○	○	○	○
Plastic resin	○	○	○	○	○	○	○	○	○	○
Chip	○	○	○	○	○	○	○	○	○	○
The lead	○	○	○	○	○	○	○	○	○	○
Plastic sheet installed	○	○	○	○	○	○	○	○	○	○
explanation	○: Indicates that the content of hazardous substances or elements in the detection limit of the following the SJ/T11363-2006 standard. ×: Indicates that the content of hazardous substances or elements exceeding the SJ/T11363-2006 Standard limit requirements.									

6.2、 Notes

We Recommend you to read this chapter carefully before using this product.

The information in this chapter is provided for reference only and i-Core disclaims any express or implied warranties, including but not limited to applicability, special application or non-infringement of third party rights.

This product is not suitable for critical equipment such as life-saving, life-sustaining or safety equipment. It is also not suitable for applications that may result in personal injury, death, or serious property or environmental damage due to product malfunction or failure. I-Core will not be liable for any damages incurred by the customers at their own risk for such applications.

The customer is responsible for conducting all necessary tests i-Core's application to avoid failure in the application or the application of the customer's third party users. I-Core does not accept any liability.

The Company reserves the right to change or improve the information published in this chapter at any time.

The information in this chapter are subject to change without notice. We recommend the customer to consult our sales staff before purchasing.

Please obtain related materials form i-Core's regular channels and we are not responsible for its content if it is provided by sources other than our company.

In case of any conflict between the Chinese and English version, the version is subject to the Chinese one.