



AiP74LVC240

Octal Buffer/Line Driver; 3-State; Inverting

Product Specification

Specification Revision History:

Version	Date	Description
2024-11-A0	2024-11	New
2025-02-A1	2025-02	Modify the parameters



1、General Description

The AiP74LVC240 is an octal non-inverting buffer/line driver with 3-state outputs. The 3-state outputs are controlled by the output enable inputs $1\overline{OE}$ and $2\overline{OE}$. A HIGH on $n\overline{OE}$ causes the outputs to assume a high-impedance OFF-state.

Inputs can be driven from either 3.3V or 5V devices. In 3-state operation, outputs can handle 5V. These features allow the use of these devices as translators in a mixed 3.3V and 5V environment.

Features:

- Supply voltage range: 1.2V to 3.6V
- Inputs accept voltages up to 5.5V
- $\pm 24\text{mA}$ output drive at 3.0V
- High-impedance when $V_{CC}=0\text{V}$
- Temperature range: -40°C to $+125^{\circ}\text{C}$
- Packaging information: SOP20/TSSOP20/DHVQFN20

Ordering Information:

Reel packing specifications:

Part number	Packaging form	Marking code	Reel quantity	Boxed reel quantity	Notes
AiP74LVC240SA20.TR	SOP20	74LVC240	2000 PCS/reel	2000 PCS/box	Dimensions of plastic enclosure: 12.8mm \times 7.5mm Pin spacing: 1.27mm
AiP74LVC240TA20.TR	TSSOP20	74LVC240	4000 PCS/reel	8000 PCS/box	Dimensions of plastic enclosure: 6.5mm \times 4.4mm Pin spacing: 0.65mm
AiP74LVC240QE20.TR	DHVQFN20	74LVC240	3000 PCS/reel	3000 PCS/box	Dimensions of plastic enclosure: 4.5mm \times 2.5mm Pin spacing: 0.5mm

Note: If the physical information is inconsistent with the ordering information, please refer to the actual product.



2、Block Diagram And Pin Description

2.1、Block Diagram

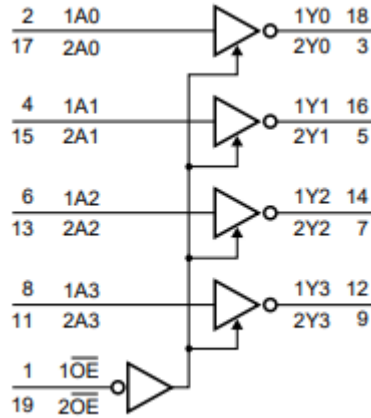

Figure 1. Logic symbol

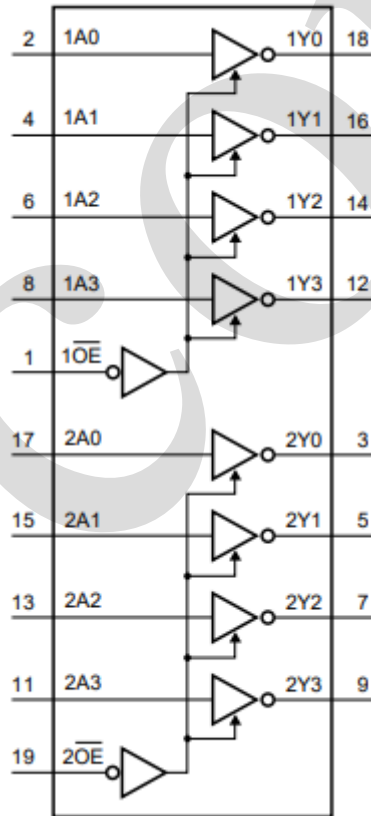
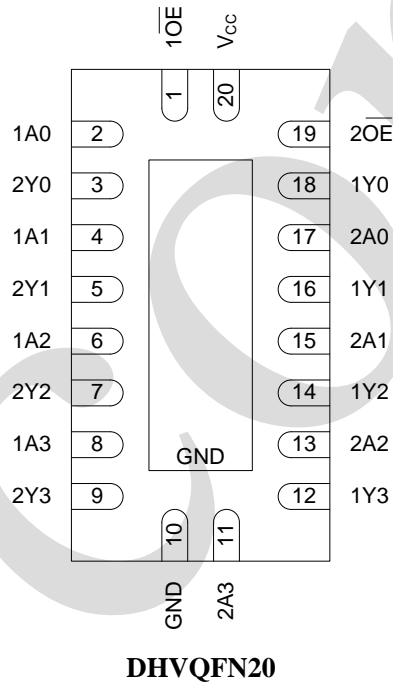
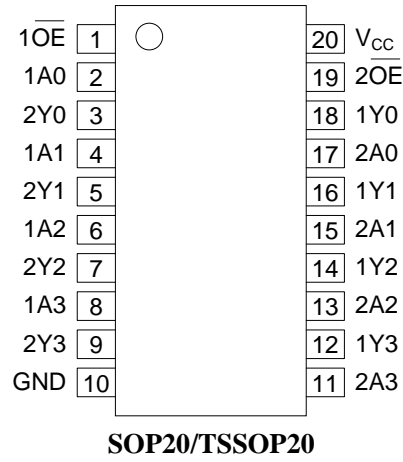

Figure 2. Functional diagram



2.2、Pin Configurations





2.3、Pin Description

Pin No.	Pin Name	Description
1	$\overline{1OE}$	output enable input (active LOW)
2	1A0	data input
3	2Y0	bus output
4	1A1	data input
5	2Y1	bus output
6	1A2	data input
7	2Y2	bus output
8	1A3	data input
9	2Y3	bus output
10	GND	ground (0V)
11	2A3	data input
12	1Y3	bus output
13	2A2	data input
14	1Y2	bus output
15	2A1	data input
16	1Y1	bus output
17	2A0	data input
18	1Y0	bus output
19	$\overline{2OE}$	output enable input (active LOW)
20	V _{CC}	supply voltage

2.4、Function Table

Input		Output
\overline{nOE}	nAn	nYn
L	L	H
L	H	L
H	X	Z

Note: H=HIGH voltage level; L=LOW voltage level; X=don't care; Z=high-impedance OFF-state.



3、Electrical Parameter

3.1、Absolute Maximum Ratings

(Voltages are referenced to GND (ground=0V), unless otherwise specified.)

Parameter	Symbol	Conditions	Min.	Max.	Unit
supply voltage	V_{CC}	-	-0.5	+6.5	V
input voltage	V_I	-	-0.5	+6.5	V
output voltage	V_O	Active mode	-0.5	$V_{CC}+0.5$	V
		Power-down mode; $V_{CC}=0V$	-0.5	+6.5	V
		output 3-state	-0.5	+6.5	V
supply current	I_{CC}	-	-	100	mA
ground current	I_{GND}	-	-100	-	mA
input clamping current	I_{IK}	$V_I < 0V$	-50	-	mA
output current	I_O	$V_O=0V$ to V_{CC}	-	± 50	mA
output clamping current	I_{OK}	$V_O > V_{CC}$ or $V_O < 0V$	-	± 50	mA
storage temperature	T_{stg}	-	-65	+150	$^{\circ}C$
soldering temperature	T_L	10s	-	260	$^{\circ}C$

3.2、Recommended Operating Conditions

Parameter	Symbol	Conditions	Min.	Typ.	Max.	Unit
supply voltage	V_{CC}	-	1.2	-	3.6	V
input voltage	V_I	-	0	-	5.5	V
output voltage	V_O	Active mode	0	-	V_{CC}	V
		Power-down mode; $V_{CC}=0V$	0	-	5.5	V
		output 3-state	0	-	5.5	V
ambient temperature	T_{amb}	-	-40	-	+125	$^{\circ}C$

3.3、Electrical Characteristics

3.3.1、DC Characteristics 1

($T_{amb}=-40^{\circ}C$ to $+85^{\circ}C$, voltages are referenced to GND (ground=0V), unless otherwise specified.)

Parameter	Symbol	V_{CC}	Conditions	Min.	Typ.	Max.	Unit
HIGH-level input voltage	V_{IH}	1.2V	-	1.08	-	-	V
		1.65V to	-	$0.65 \times V_{CC}$	-	-	V
		2.3V to 2.7V	-	1.7	-	-	V
		2.7V to 3.6V	-	2.0	-	-	V
LOW-level input voltage	V_{IL}	1.2V	-	-	-	0.12	V
		1.65V to	-	-	-	$0.35 \times V_{CC}$	V
		2.3V to 2.7V	-	-	-	0.7	V
		2.7V to 3.6V	-	-	-	0.8	V
HIGH-level output voltage	V_{OH}	1.65V to 3.6V	$I_O=-100\mu A$	$V_{CC}-0.2$	-	-	V
		1.65V	$I_O=-4mA$	1.2	-	-	V
		2.3V	$I_O=-8mA$	1.8	-	-	V
		2.7V	$I_O=-12mA$	2.2	-	-	V
		3.0V	$I_O=-18mA$	2.4	-	-	V
		3.0V	$I_O=-24mA$	2.2	-	-	V



LOW-level output voltage	V_{OL}	1.65V to 3.6V	$I_O=100\mu A$	-	-	0.2	V
		1.65V	$I_O=4mA$	-	-	0.45	V
		2.3V	$I_O=8mA$	-	-	0.6	V
		2.7V	$I_O=12mA$	-	-	0.4	V
		3.0V	$I_O=24mA$	-	-	0.55	V
Input leakage current	I_I	3.6V	$V_I=5.5V$ or GND	-	-	± 5	μA
OFF-state output current	I_{OZ}	3.6V	$V_I=V_{IH}$ or V_{IL} ; $V_O=5.5V$ or GND	-	-	± 5	μA
power-off leakage current	I_{OFF}	0V	V_I or $V_O=5.5V$	-	-	± 10	μA
supply current	I_{CC}	3.6V	$V_I=V_{CC}$ or GND; $I_O=0A$	-	-	10	μA
additional supply current	ΔI_{CC}	2.7V to 3.6V	per input pin; $V_I=V_{CC}-0.6V$; $I_O=0A$	-	-	500	μA

3.3.2、DC Characteristics 2

($T_{amb}=-40^{\circ}C$ to $+125^{\circ}C$, voltages are referenced to GND (ground=0V), unless otherwise specified.)

Parameter	Symbol	V_{CC}	Conditions	Min.	Typ.	Max.	Unit
HIGH-level input voltage	V_{IH}	1.2V	-	1.08	-	-	V
		1.65V to	-	$0.65 \times V_{CC}$	-	-	V
		2.3V to 2.7V	-	1.7	-	-	V
		2.7V to 3.6V	-	2.0	-	-	V
LOW-level input voltage	V_{IL}	1.2V	-	-	-	0.12	V
		1.65V to	-	-	-	$0.35 \times V_{CC}$	V
		2.3V to 2.7V	-	-	-	0.7	V
		2.7V to 3.6V	-	-	-	0.8	V
HIGH-level output voltage	V_{OH}	1.65V to 3.6V	$I_O=-100\mu A$	$V_{CC}-0.3$	-	-	V
		1.65V	$I_O=-4mA$	1.05	-	-	V
		2.3V	$I_O=-8mA$	1.65	-	-	V
		2.7V	$I_O=-12mA$	2.05	-	-	V
		3.0V	$I_O=-18mA$	2.25	-	-	V
		3.0V	$I_O=-24mA$	2.0	-	-	V
LOW-level output voltage	V_{OL}	1.65V to 3.6V	$I_O=100\mu A$	-	-	0.3	V
		1.65V	$I_O=4mA$	-	-	0.65	V
		2.3V	$I_O=8mA$	-	-	0.8	V
		2.7V	$I_O=12mA$	-	-	0.6	V
		3.0V	$I_O=24mA$	-	-	0.8	V
input leakage	I_I	3.6V	$V_I=5.5V$ or GND	-	-	± 20	μA
OFF-state output current	I_{OZ}	3.6V	$V_I=V_{IH}$ or V_{IL} ; $V_O=5.5V$ or GND	-	-	± 20	μA
power-off leakage current	I_{OFF}	0V	V_I or $V_O=5.5V$	-	-	± 20	μA
supply current	I_{CC}	3.6V	$V_I=V_{CC}$ or GND; $I_O=0A$	-	-	40	μA



additional supply current	ΔI_{CC}	2.7V to 3.6V	per input pin; $V_I = V_{CC} - 0.6V$; $I_O = 0A$	-	-	5000	μA
---------------------------	-----------------	--------------	---	---	---	------	---------

3.3.3、AC Characteristics 1

($T_{amb} = -40^{\circ}C$ to $+85^{\circ}C$, voltages are referenced to GND (ground=0V), unless otherwise specified.)

Parameter	Symbol	V _{CC}	Conditions	Min.	Typ.	Max.	Unit
nAn to nBn nBn to nAn propagation delay	t_{PLH}, t_{PHL}	1.2V	see Figure 4	-	16	-	ns
		1.65V to 1.95V		1.0	5.7	12.7	ns
		2.3V to 2.7V		0.5	3.0	6.6	ns
		2.7V		1.5	3.1	7.0	ns
		3.0V to 3.6V		1.3	2.6	5.5	ns
$\bar{n}OE$ to nAn/nBn enable time	t_{PZH}, t_{PZL}	1.2V	see Figure 5	-	19	-	ns
		1.65V to 1.95V		1.5	6.3	15.9	ns
		2.3V to 2.7V		1.5	3.6	8.8	ns
		2.7V		1.0	3.7	8.5	ns
		3.0V to 3.6V		1.1	2.9	7.0	ns
$\bar{n}OE$ to nAn/nBn disable time	t_{PLZ}, t_{PHZ}	1.2V	see Figure 5	-	17	-	ns
		1.65V to 1.95V		2.3	4.1	9.9	ns
		2.3V to 2.7V		1.0	3.4	5.6	ns
		2.7V		1.5	3.1	7.5	ns
		3.0V to 3.6V		1.4	2.9	6.0	ns

Note: Typical values are measured at $T_{amb} = 25^{\circ}C$ and $V_{CC} = 1.8V, 2.5V, 2.7V,$ and $3.3V$ respectively.

3.3.4、AC Characteristics 2

($T_{amb} = -40^{\circ}C$ to $+125^{\circ}C$, voltages are referenced to GND (ground=0V), unless otherwise specified.)

Parameter	Symbol	V _{CC}	Conditions	Min.	Typ.	Max.	Unit
nAn to nBn nBn to nAn propagation delay	t_{PLH}, t_{PHL}	1.65V to 1.95V	see Figure 4	1.0	-	14.6	ns
		2.3V to 2.7V		0.5	-	7.6	ns
		2.7V		1.5	-	9.0	ns
		3.0V to 3.6V		1.3	-	7.0	ns
$\bar{n}OE$ to nAn/nBn enable time	t_{PZH}, t_{PZL}	1.65V to 1.95V	see Figure 5	1.5	-	18.3	ns
		2.3V to 2.7V		1.5	-	10.1	ns
		2.7V		1.0	-	11.0	ns
		3.0V to 3.6V		1.1	-	9.0	ns
$\bar{n}OE$ to nAn/nBn disable time	t_{PLZ}, t_{PHZ}	1.65V to 1.95V	see Figure 5	2.3	-	11.4	ns
		2.3V to 2.7V		1.0	-	6.5	ns
		2.7V		1.5	-	9.5	ns
		3.0V to 3.6V		1.4	-	7.5	ns



4、Testing Circuit

4.1、AC Testing Circuit

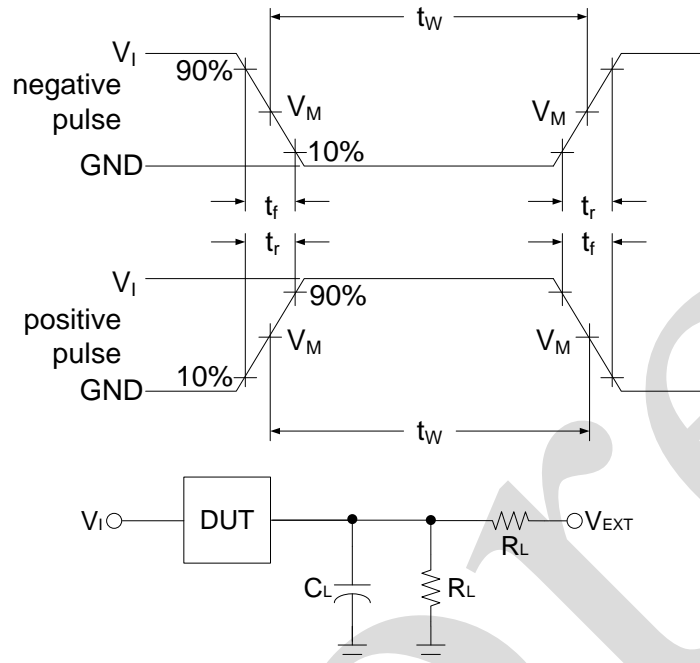

Figure 3. Load circuit

C_L =Load capacitance including jig and probe capacitance.

R_L =Load resistance.

4.2、Test Data

Supply voltage	Input		Load		V_{EXT}		
	V_I	t_r, t_f	C_L	R_L	t_{PLH}, t_{PHL}	t_{PLZ}, t_{PZL}	t_{PHZ}, t_{PZH}
1.2V	V_{CC}	$\leq 2ns$	30pF	1k Ω	open	$2 \times V_{CC}$	GND
1.65V to 1.95V	V_{CC}	$\leq 2ns$	30pF	1k Ω	open	$2 \times V_{CC}$	GND
2.3V to 2.7V	V_{CC}	$\leq 2ns$	30pF	500 Ω	open	$2 \times V_{CC}$	GND
2.7V	2.7V	$\leq 2.5ns$	50pF	500 Ω	open	$2 \times V_{CC}$	GND
3.0V to 3.6V	2.7V	$\leq 2.5ns$	50pF	500 Ω	open	$2 \times V_{CC}$	GND



4.3. AC Testing Waveforms

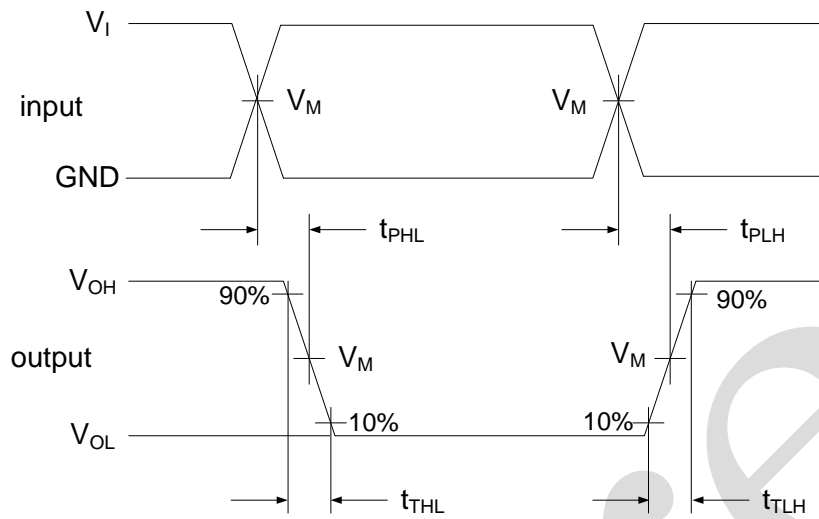

Figure 4. The data input (A) to output (Y) propagation delays

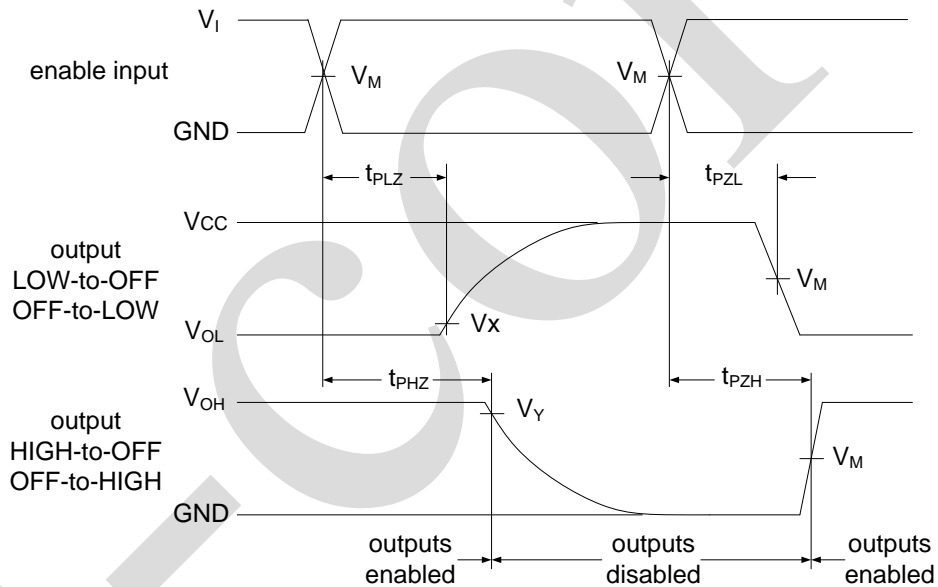

Figure 5. 3-state enable and disable times

4.4. Measurement Points

Supply voltage	Input	Output		
V _{CC}	V _M	V _M	V _X	V _Y
1.2V	0.5×V _{CC}	0.5×V _{CC}	V _{OL} +0.15V	V _{OH} -0.15V
1.65V to 1.95V	0.5×V _{CC}	0.5×V _{CC}	V _{OL} +0.15V	V _{OH} -0.15V
2.3V to 2.7V	0.5×V _{CC}	0.5×V _{CC}	V _{OL} +0.15V	V _{OH} -0.15V
2.7V	1.5V	1.5V	V _{OL} +0.3V	V _{OH} -0.3V
3.0V to 3.6V	1.5V	1.5V	V _{OL} +0.3V	V _{OH} -0.3V



5、Package Information

5.1、SOP20

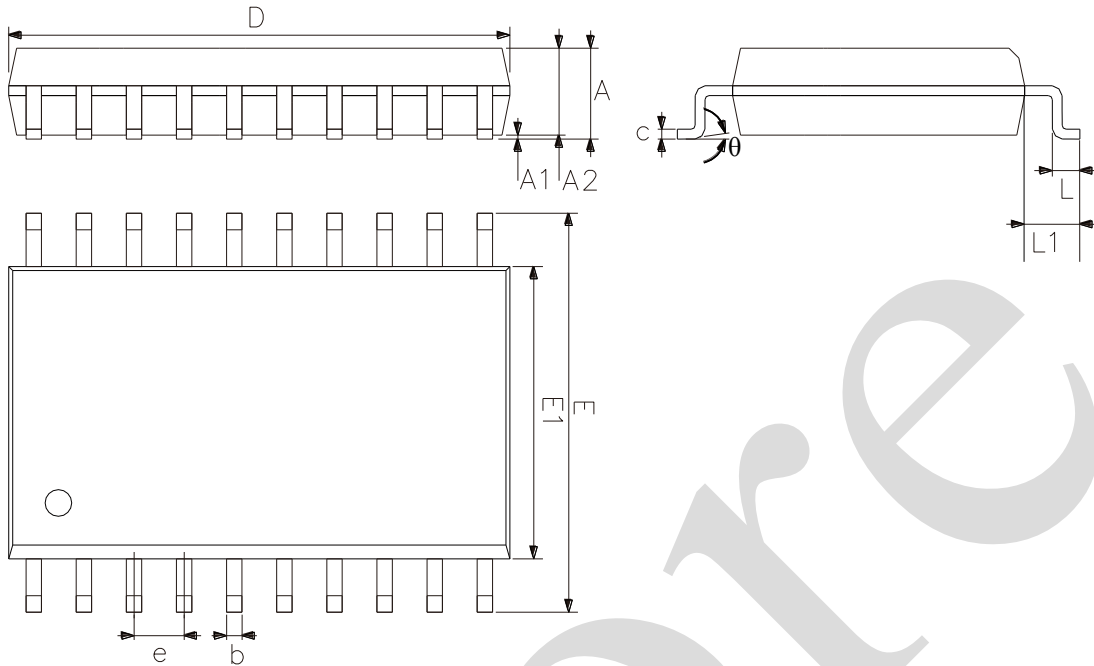

2023/12/A	Dimensions In Millimeters	
Symbol	Min.	Max.
A	2.47	2.65
A1	0.05	0.30
A2	2.20	2.44
b	0.35	0.50
c	0.15	0.30
D	12.54	12.94
E	10.00	10.60
E1	7.30	7.70
e	1.27	
L	0.40	1.05
L1	1.30	1.50
θ	0°	8°

Note: The package dimensions do not include flash and burrs, and the dimensions of flash and burrs shall not exceed 0.15mm.



5.2、TSSOP20

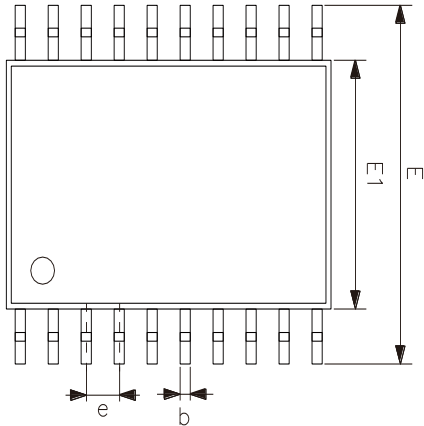
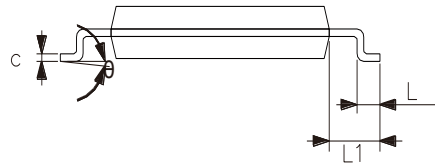
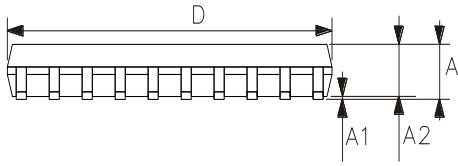

2023/12/A	Dimensions In Millimeters	
Symbol	Min	Max
A	—	1.20
A1	0.05	0.15
A2	0.80	1.05
b	0.19	0.30
c	0.09	0.20
D	6.40	6.60
E1	4.30	4.50
E	6.20	6.60
e	0.65	
L	0.45	0.75
L1	1.00	
θ	0°	8°

Note: The package dimensions do not include flash and burrs, and the dimensions of flash and burrs shall not exceed 0.15mm.



5.3、DHVQFN20

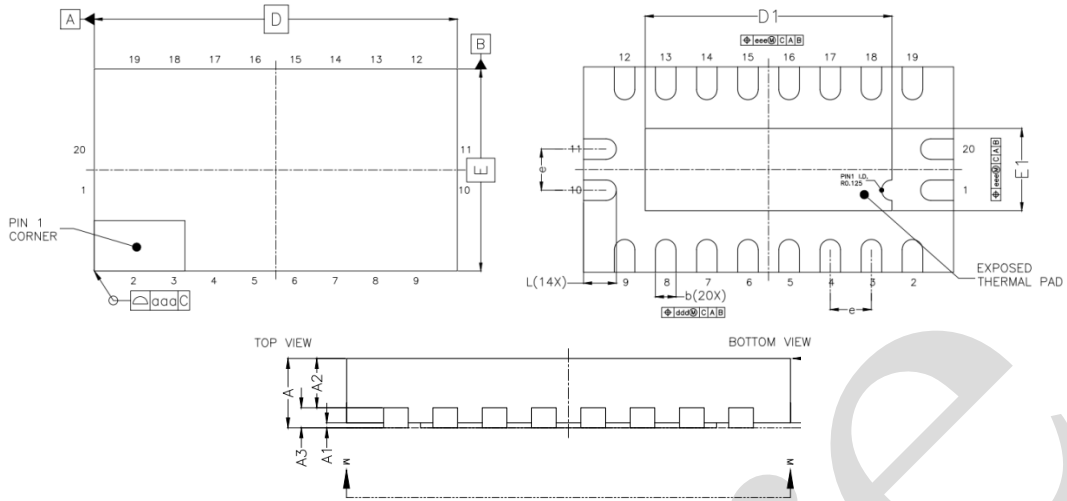

2023/12/A	Dimensions In Millimeters	
Symbol	Min	Max
A	0.80	1.00
A1	0.00	0.05
A2	0.60	0.70
A3	0.20	
D	4.40	4.60
E	2.40	2.60
e	0.50	
b	0.18	0.30
L	0.30	0.50
D1	2.70	3.15
E1	0.70	1.15

Note: The package dimensions do not include flash and burrs, and the dimensions of flash and burrs shall not exceed 0.15mm.



6、 Statements And Notes

6.1、 The name and content of Hazardous substances or Elements in the product

Part name	Hazardous substances or Elements									
	Lead and lead compounds	Mercury and mercury compounds	Cadmium and cadmium compounds	Hexavalent chromium compounds	Polybrominated biphenyls	Polybrominated biphenyl ethers	Dibutyl phthalate	Butylbenzyl phthalate	Di-2-ethylhexyl phthalate	Diisobutyl phthalate
Lead frame	○	○	○	○	○	○	○	○	○	○
Plastic resin	○	○	○	○	○	○	○	○	○	○
Chip	○	○	○	○	○	○	○	○	○	○
The lead	○	○	○	○	○	○	○	○	○	○
Plastic sheet installed	○	○	○	○	○	○	○	○	○	○
explanation	○: Indicates that the content of hazardous substances or elements in the detection limit of the following the SJ/T11363-2006 standard. ×: Indicates that the content of hazardous substances or elements exceeding the SJ/T11363-2006 Standard limit requirements.									

6.2、 Notes

We recommend you to read this chapter carefully before using this product.

The information in this chapter is provided for reference only and i-Core disclaims any express or implied warranties, including but not limited to applicability, special application or non-infringement of third party rights.

This product is not suitable for critical equipment such as life-saving, life-sustaining or safety equipment. It is also not suitable for applications that may result in personal injury, death, or serious property or environmental damage due to product malfunction or failure. I-Core will not be liable for any damages incurred by the customers at their own risk for such applications.

The customer is responsible for conducting all necessary tests i-Core's application to avoid failure in the application or the application of the customer's third party users. I-Core does not accept any liability.

The Company reserves the right to change or improve the information published in this chapter at any time. The information in this chapter are subject to change without notice. We recommend the customer to consult our sales staff before purchasing.

Please obtain related materials form i-Core's regular channels and we are not responsible for its content if it is provided by sources other than our company.

In case of any conflict between the Chinese and English version, the version is subject to the Chinese one.