



AiP74LVC07

Hex Buffer with Open-drain Outputs

Product Specification

Specification Revision History:

Version	Date	Description
2017-05-A1	2017-05	New
2023-04-B1	2023-04	Update the template
2025-05-B2	2025-05	Add VQFN14 package form



1、General Description

The AiP74LVC07 provides six non-inverting buffers. The outputs are open-drain and can be connected to other open-drain outputs to implement active-LOW wired-OR or active-HIGH wired-AND functions.

Inputs can be driven from either 3.3V or 5V devices. This feature allows the use of these devices as translators in mixed 3.3V and 5V applications.

Features:

- 5V tolerant inputs and outputs (open-drain) for interfacing with 5V logic
- Wide supply voltage range from 1.2V to 5.5V
- CMOS low power consumption
- Direct interface with TTL levels
- Inputs accept voltages up to 5V
- Specified from -40°C to +125°C
- Packaging information: DIP14/SOP14/TSSOP14/VQFN14

**Ordering Information:****Tube packing specifications:**

Part number	Packaging form	Marking code	Tube quantity	Boxed tube quantity	Boxed quantity	Notes
AiP74LVC07DA14.TB	DIP14	74LVC07	25 PCS/tube	40 tube/box	1000 PCS/box	Dimensions of plastic enclosure: 19.0mm×6.4mm Pin spacing: 2.54mm
AiP74LVC07SA14.TB	SOP14	74LVC07	50 PCS/tube	200 tube/box	10000 PCS/box	Dimensions of plastic enclosure: 8.7mm×3.9mm Pin spacing: 1.27mm
AiP74LVC07TA14.TB	TSSOP14	74LVC07	96 PCS/tube	200 tube/box	19200 PCS/box	Dimensions of plastic enclosure: 5.0mm×4.4mm Pin spacing: 0.65mm

Reel packing specifications:

Part number	Packaging form	Marking code	Reel quantity	Boxed reel quantity	Notes
AiP74LVC07SA14.TR	SOP14	74LVC07	4000 PCS/reel	8000 PCS/box	Dimensions of plastic enclosure: 8.7mm×3.9mm Pin spacing: 1.27mm
AiP74LVC07TA14.TR	TSSOP14	74LVC07	5000 PCS/reel	10000 PCS/box	Dimensions of plastic enclosure: 5.0mm×4.4mm Pin spacing: 0.65mm
AiP74LVC07QK14.TR	VQFN14	74LVC07	5000 PCS/reel	10000 PCS/box	Dimensions of plastic enclosure: 3.5mm×3.5mm 3in spacing: 0.50mm

Note: If the physical information is inconsistent with the ordering information, please refer to the actual product.



2、Block Diagram And Pin Description

2.1、Block Diagram

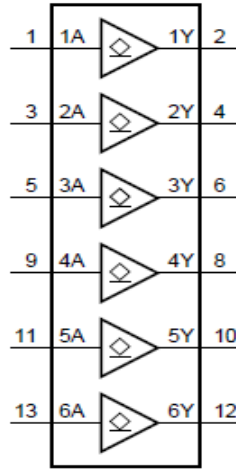

Figure 1. Logic symbol

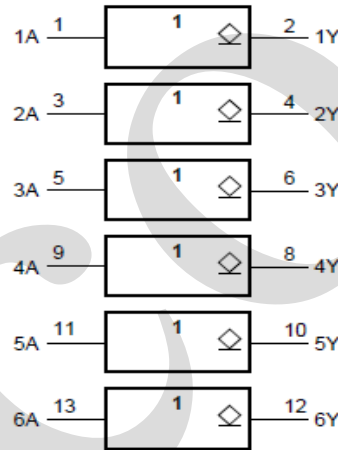

Figure 2. IEC logic symbol

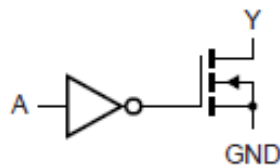
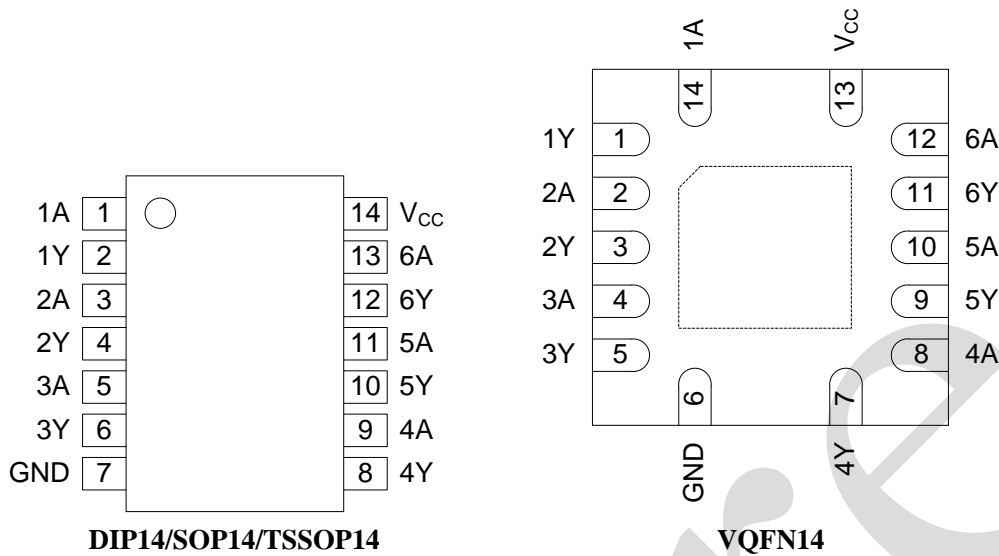

Figure 3. Logic diagram for one gate



2.2、Pin Configurations



2.3、Pin Description

Pin No.		Pin Name	Description
DIP14/SOP14/TSSOP14	VQFN14		
1	14	1A	data input
2	1	1Y	data output
3	2	2A	data input
4	3	2Y	data output
5	4	3A	data input
6	5	3Y	data output
7	6	GND	ground (0V)
8	7	4Y	data output
9	8	4A	data input
10	9	5Y	data output
11	10	5A	data input
12	11	6Y	data output
13	12	6A	data input
14	13	V _{CC}	supply voltage

2.4、Function Table

Input	Output
nA	nY
L	L
H	Z

Note: H=HIGH voltage level; L=LOW voltage level; Z=high-impedance OFF-state.



3、Electrical Parameter

3.1、Absolute Maximum Ratings

(Voltages are referenced to GND(ground=0V), unless otherwise specified.)

Parameter	Symbol	Conditions	Min.	Max.	Unit	
supply voltage	V_{CC}	-	-0.5	+6.5	V	
input clamping current	I_{IK}	$V_I < 0V$	-50	-	mA	
input voltage	V_I	-	-0.5	+6.5	V	
output clamping current	I_{OK}	$V_O < 0V$	-50	-	mA	
output voltage	V_O	active mode	-0.5	+6.5	V	
		high-impedance mode	-0.5	+6.5	V	
output current	I_O	$V_O = 0V$ to V_{CC}	-	50	mA	
supply current	I_{CC}	-	-	100	mA	
ground current	I_{GND}	-	-100	-	mA	
total power dissipation	P_{tot}	-	-	500	mW	
storage temperature	T_{stg}	-	-65	+150	°C	
Soldering temperature	T_L	10s	DIP		245	°C
			SOP/TSSOP/VQFN		260	

3.2、Recommended Operating Conditions

Parameter	Symbol	Conditions	Min.	Typ.	Max.	Unit
supply voltage	V_{CC}	-	1.65	-	5.5	V
		functional	1.2	-	-	V
input voltage	V_I	-	0	-	5.5	V
output voltage	V_O	active mode	0	-	V_{CC}	V
		high-impedance mode	0	-	5.5	V
ambient temperature	T_{amb}	-	-40	-	+125	°C
input transition rise and fall rate	$\Delta t/\Delta V$	$V_{CC} = 1.65V$ to $2.7V$	0	-	20	ns/V
		$V_{CC} = 2.7V$ to $3.6V$	0	-	10	ns/V



3.3、Electrical Characteristics

3.3.1、DC Characteristics 1

($T_{amb} = -40^{\circ}\text{C}$ to $+85^{\circ}\text{C}$, voltages are referenced to GND (ground=0V), unless otherwise specified.)

Parameter	Symbol	Conditions	Min.	Typ.	Max.	Unit	
HIGH-level input voltage	V_{IH}	$V_{CC}=1.2\text{V}$	1.08	-	-	V	
		$V_{CC}=1.65\text{V}$ to 1.95V	$0.65 \times V_{CC}$	-	-	V	
		$V_{CC}=2.3\text{V}$ to 2.7V	1.7	-	-	V	
		$V_{CC}=2.7\text{V}$ to 3.6V	2.0	-	-	V	
		$V_{CC}=4.5\text{V}$ to 5.5V	$0.7 \times V_{CC}$	-	-	V	
LOW-level input voltage	V_{IL}	$V_{CC}=1.2\text{V}$	-	-	0.12	V	
		$V_{CC}=1.65\text{V}$ to 1.95V	-	-	$0.35 \times V_{CC}$	V	
		$V_{CC}=2.3\text{V}$ to 2.7V	-	-	0.7	V	
		$V_{CC}=2.7\text{V}$ to 3.6V	-	-	0.8	V	
		$V_{CC}=4.5\text{V}$ to 5.5V	-	-	$0.30 \times V_{CC}$	V	
LOW-level output voltage	V_{OL}	$V_I = V_{IH}$ or V_{IL}	$I_O=100\mu\text{A}; V_{CC}=1.65\text{V}$ to 5.5V	-	-	0.20	V
			$I_O=4\text{mA}; V_{CC}=1.65\text{V}$	-	-	0.45	V
			$I_O=8\text{mA}; V_{CC}=2.3\text{V}$	-	-	0.3	V
			$I_O=12\text{mA}; V_{CC}=2.7\text{V}$	-	-	0.4	V
			$I_O=24\text{mA}; V_{CC}=3.0\text{V}$	-	-	0.55	V
			$I_O=32\text{mA}; V_{CC}=4.5\text{V}$	-	-	0.55	V
input leakage current	I_I	$V_I=5.5\text{V}$ or GND; $V_{CC}=1.65\text{V}$ to 5.5V	-	-	± 5	μA	
OFF-state output current	I_{OZ}	$V_I=V_{IH}; V_O=5.5\text{V}$ or GND; $V_{CC}=1.65\text{V}$ to 5.5V	-	-	± 10	μA	
power-off leakage current	I_{OFF}	V_I or $V_O=5.5\text{V}; V_{CC}=0\text{V}$	-	-	± 10	μA	
supply current	I_{CC}	$V_I=V_{CC}$ or GND; $I_O=0\text{A}; V_{CC}=5.5\text{V}$	-	-	10	μA	
additional supply current	ΔI_{CC}	per input pin; $V_I=V_{CC}-0.6\text{V}; I_O=0\text{A}; V_{CC}=2.7\text{V}$ to 5.5V	-	-	500	μA	
input capacitance	C_I	$V_{CC}=0\text{V}$ to $5.5\text{V}; V_I=$ GND to V_{CC}	-	5.0	-	pF	

Note: All typical values are measured at $V_{CC}=3.3\text{V}$ (unless stated otherwise) and $T_{amb}=25^{\circ}\text{C}$.



3.3.2、DC Characteristics 2

($T_{amb}=-40^{\circ}\text{C}$ to $+125^{\circ}\text{C}$, voltages are referenced to GND (ground=0V), unless otherwise specified.)

Parameter	Symbol	Conditions	Min.	Typ.	Max.	Unit	
HIGH-level input voltage	V_{IH}	$V_{CC}=1.2\text{V}$	1.08	-	-	V	
		$V_{CC}=1.65\text{V}$ to 1.95V	$0.65 \times V_{CC}$	-	-	V	
		$V_{CC}=2.3\text{V}$ to 2.7V	1.7	-	-	V	
		$V_{CC}=2.7\text{V}$ to 3.6V	2.0	-	-	V	
		$V_{CC}=4.5\text{V}$ to 5.5V	$0.7 \times V_{CC}$	-	-	V	
LOW-level input voltage	V_{IL}	$V_{CC}=1.2\text{V}$	-	-	0.12	V	
		$V_{CC}=1.65\text{V}$ to 1.95V	-	-	$0.35 \times V_{CC}$	V	
		$V_{CC}=2.3\text{V}$ to 2.7V	-	-	0.7	V	
		$V_{CC}=2.7\text{V}$ to 3.6V	-	-	0.8	V	
		$V_{CC}=4.5\text{V}$ to 5.5V	-	-	$0.30 \times V_{CC}$	V	
LOW-level output voltage	V_{OL}	$V_I=V_{IH}$ or V_{IL}	$I_O=100\mu\text{A}; V_{CC}=1.65\text{V}$ to 5.5V	-	-	0.30	V
			$I_O=4\text{mA}; V_{CC}=1.65\text{V}$	-	-	0.6	V
			$I_O=8\text{mA}; V_{CC}=2.3\text{V}$	-	-	0.75	V
			$I_O=12\text{mA}; V_{CC}=2.7\text{V}$	-	-	0.6	V
			$I_O=24\text{mA}; V_{CC}=3.0\text{V}$	-	-	0.8	V
			$I_O=32\text{mA}; V_{CC}=4.5\text{V}$	-	-	0.8	V
input leakage current	I_I	$V_I=5.5\text{V}$ or GND; $V_{CC}=1.65\text{V}$ to 5.5V	-	-	± 20	μA	
OFF-state output current	I_{OZ}	$V_I=V_{IH}; V_O=5.5\text{V}$ or GND; $V_{CC}=1.65\text{V}$ to 5.5V	-	-	± 20	μA	
power-off leakage current	I_{OFF}	V_I or $V_O=5.5\text{V}; V_{CC}=0\text{V}$	-	-	± 20	μA	
supply current	I_{CC}	$V_I=V_{CC}$ or GND; $I_O=0\text{A}; V_{CC}=5.5\text{V}$	-	-	40	μA	
additional supply current	ΔI_{CC}	per input pin; $V_I=V_{CC}-0.6\text{V}; I_O=0\text{A}; V_{CC}=2.7\text{V}$ to 5.5V	-	-	5000	μA	

Note: All typical values are measured at $V_{CC}=3.3\text{V}$ (unless stated otherwise) and $T_{amb}=25^{\circ}\text{C}$.



3.3.3、AC Characteristics 1

($T_{amb}=-40^{\circ}C$ to $+85^{\circ}C$, voltages are referenced to GND (ground=0V), unless otherwise specified.)

Parameter	Symbol	Conditions	Min.	Typ.	Max.	Unit	
nA to nY OFF-state to LOW propagation delay	tpZL	see Figure 5	V _{CC} =1.2V	-	8.0	-	ns
			V _{CC} =1.65V to 1.95V	0.5	1.7	5.5	ns
			V _{CC} =2.3V to 2.7V	0.5	1.2	2.8	ns
			V _{CC} =2.7V	0.5	1.8	3.3	ns
			V _{CC} =3.0V to 3.6V	0.5	1.2	3.6	ns
			V _{CC} =4.5V to 5.5V	0.5	1.6	2.6	ns
nA to nY LOW to OFF-state propagation delay	tPLZ	see Figure 5	V _{CC} =1.2V	-	10	-	ns
			V _{CC} =1.65V to 1.95V	0.5	3.0	5.5	ns
			V _{CC} =2.3V to 2.7V	0.5	1.7	2.8	ns
			V _{CC} =2.7V	0.5	2.1	3.3	ns
			V _{CC} =3.0V to 3.6V	0.5	2.5	3.6	ns
			V _{CC} =4.5V to 5.5V	0.5	1.6	2.6	ns
Power dissipation capacitance	C _{PD}	per buffer; V _I = GND to V _{CC}	V _{CC} =1.65V to 1.95V	-	6.5	-	pF
			V _{CC} =2.3V to 2.7V	-	6.9	-	pF
			V _{CC} =3.0V to 3.6V	-	7.2	-	pF

Note:

[1] Typical values are measured at $T_{amb}=25^{\circ}C$ and $V_{CC}=1.2V, 1.8V, 2.5V, 2.7V, 3.3V$ and $5.0V$ respectively.

[2] C_{PD} is used to determine the dynamic power dissipation (P_D in uW).

$$P_D=(C_{PD} \times V_{CC}^2 \times f_i \times N) + \sum(C_L \times V_{CC}^2 \times f_o) \text{ where:}$$

f_i=input frequency in MHz;

f_o=output frequency in MHz;

C_L=output load capacitance in pF;

V_{CC}=supply voltage in V;

N=number of inputs switching;

$\sum(C_L \times V_{CC}^2 \times f_o)$ =sum of outputs.

3.3.4、AC Characteristics 2

($T_{amb}=-40^{\circ}C$ to $+125^{\circ}C$, voltages are referenced to GND (ground=0V), unless otherwise specified.)

Parameter	Symbol	Conditions	Min.	Typ.	Max.	Unit	
nA to nY OFF-state to LOW propagation delay	tpZL	see Figure 5	V _{CC} =1.65V to 1.95V	0.5	-	6.5	ns
			V _{CC} =2.3V to 2.7V	0.5	-	3.5	ns
			V _{CC} =2.7V	0.5	-	4.5	ns
			V _{CC} =3.0V to 3.6V	0.5	-	4.5	ns
			V _{CC} =4.5V to 5.5V	0.5	-	3.5	ns
			nA to nY LOW to OFF-state propagation delay	tPLZ	see Figure 5	V _{CC} =1.65V to 1.95V	0.5
V _{CC} =2.3V to 2.7V	0.5	-				3.5	ns
V _{CC} =2.7V	0.5	-				4.5	ns
V _{CC} =3.0V to 3.6V	0.5	-				4.5	ns
V _{CC} =4.5V to 5.5V	0.5	-				3.5	ns

Note: [1] Typical values are measured at $T_{amb}=25^{\circ}C$ and $V_{CC}=1.2V, 1.8V, 2.5V, 2.7V, 3.3V$ and $5.0V$



respectively.

4、 Testing Circuit

4.1、 AC Testing Circuit

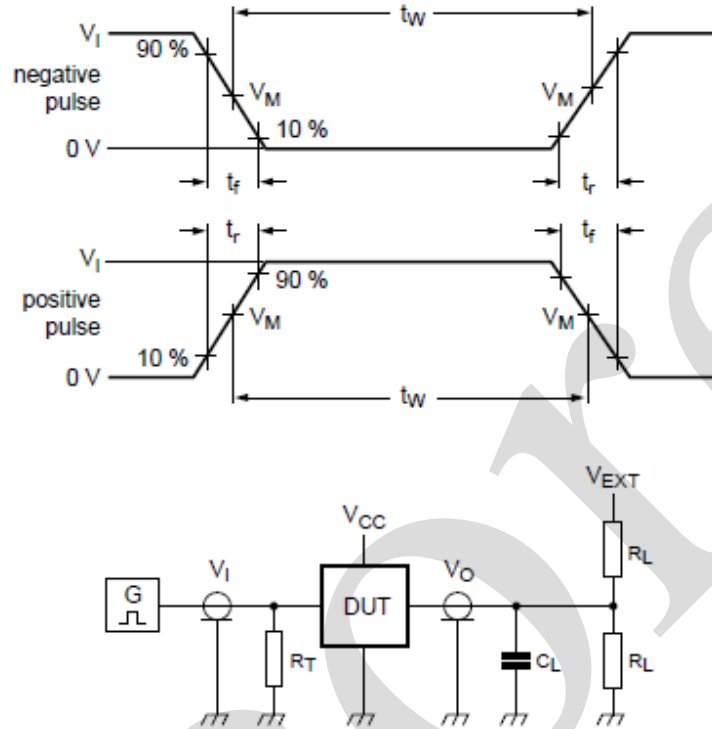

Figure 4. Load circuitry for switching times

Definitions for test circuit:

R_L =Load resistance.

C_L =Load capacitance including jig and probe capacitance.

R_T =Termination resistance should be equal to the output impedance Z_o of the pulse generator.

V_{EXT} =External voltage for measuring switching times.

4.2、 AC Testing Waveforms

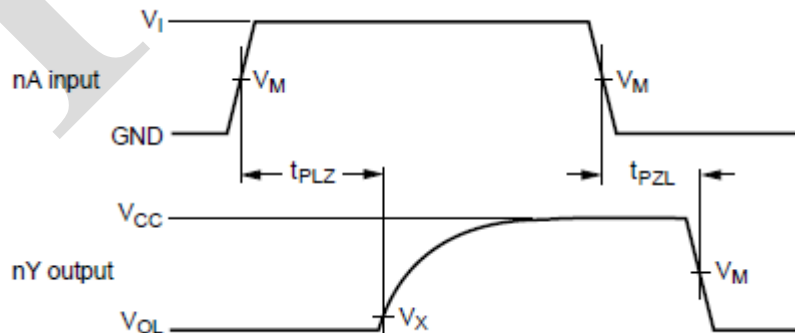

Figure 5. The input (nA) to output (nY) propagation delays



4.3、Measurement Points

Supply voltage	Input	Output
V_{CC}	V_M	V_X
$< 2.7V$	$0.5 \times V_{CC}$	$V_{OL} + 0.15V$
$\geq 2.7V$ to $3.6V$	$1.5V$	$V_{OL} + 0.3V$
$\geq 4.5V$ to $5.5V$	$0.5 \times V_{CC}$	$V_{OL} + 0.3V$

4.4、Test Data

Supply voltage	Input		Load		V_{EXT}		
	V_I	t_r, t_f	C_L	R_L	t_{PLH}, t_{PHL}	t_{PLZ}, t_{PZL}	t_{PHZ}, t_{PZH}
1.2V	V_{CC}	$\leq 2.0ns$	30pF	1k Ω	open	$2 \times V_{CC}$	GND
1.65V to 1.95V	V_{CC}	$\leq 2.0ns$	30pF	1k Ω	open	$2 \times V_{CC}$	GND
2.3V to 2.7V	V_{CC}	$\leq 2.0ns$	30pF	500 Ω	open	$2 \times V_{CC}$	GND
2.7V	2.7V	$\leq 2.5ns$	50pF	500 Ω	open	$2 \times V_{CC}$	GND
3.0V to 3.6V	2.7V	$\leq 2.5ns$	50pF	500 Ω	open	$2 \times V_{CC}$	GND
4.5V to 5.5V	V_{CC}	$\leq 2.5ns$	50pF	500 Ω	open	$2 \times V_{CC}$	GND



5、Package Information

5.1、DIP14

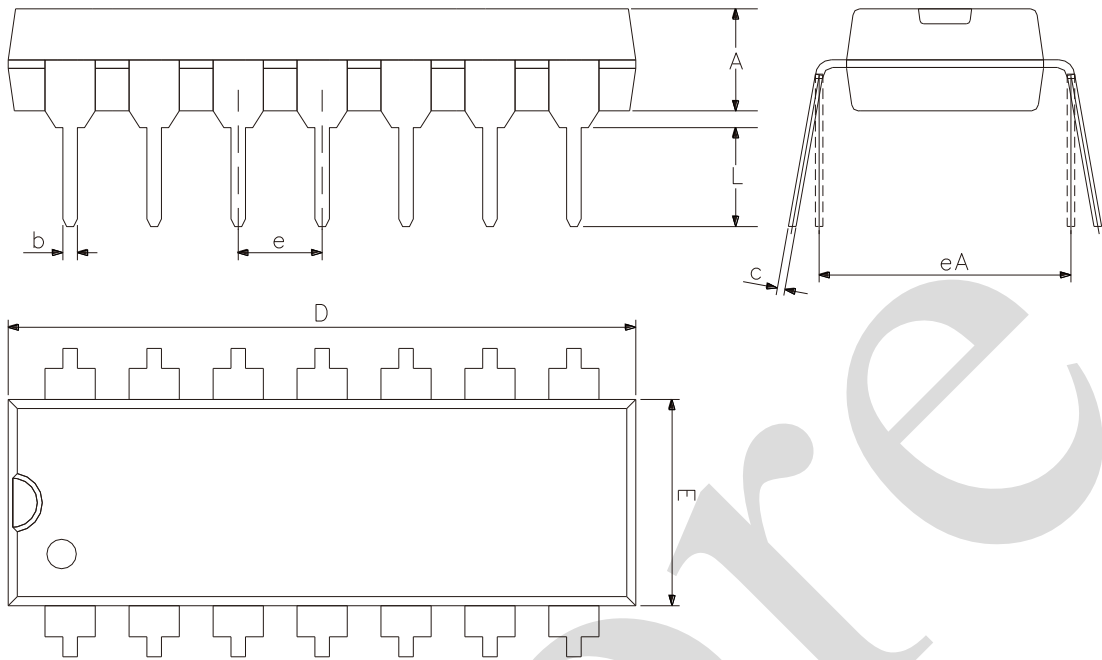

2023/12/A	Dimensions In Millimeters	
Symbol	Min	Max
A	3.05	3.60
b	0.33	0.56
c	0.20	0.36
D	18.80	19.40
E	6.20	6.60
e	2.54	
eA	7.62	10.90
L	2.92	—



5.2、SOP14

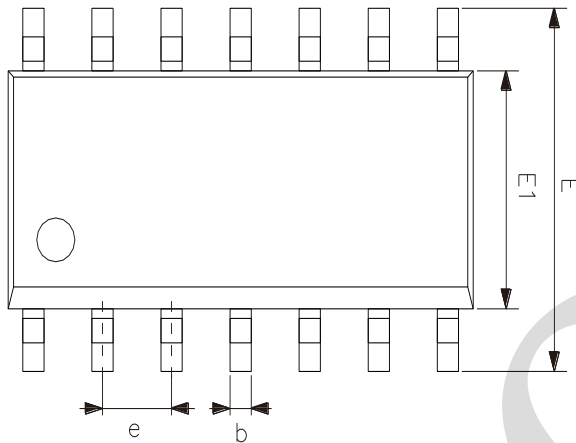
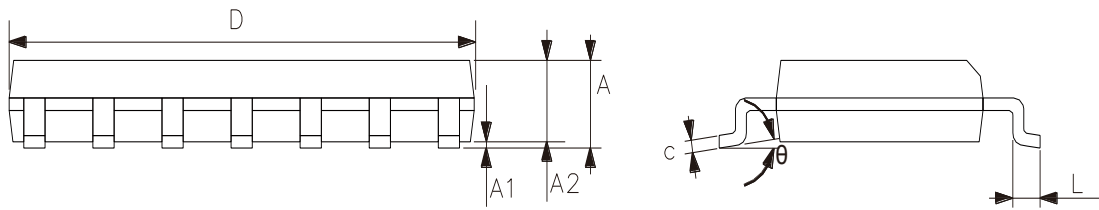

2023/12/A	Dimensions In Millimeters	
Symbol	Min.	Max.
A	1.50	1.75
A1	0.05	0.25
A2	1.30	—
b	0.33	0.50
c	0.19	0.25
D	8.43	8.76
E	5.80	6.25
E1	3.75	4.00
e	1.27	
L	0.40	0.89
θ	0°	8°



5.3、TSSOP14

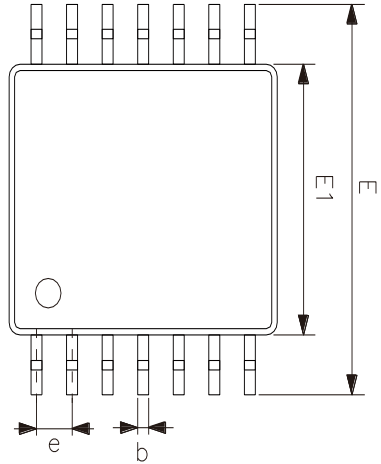
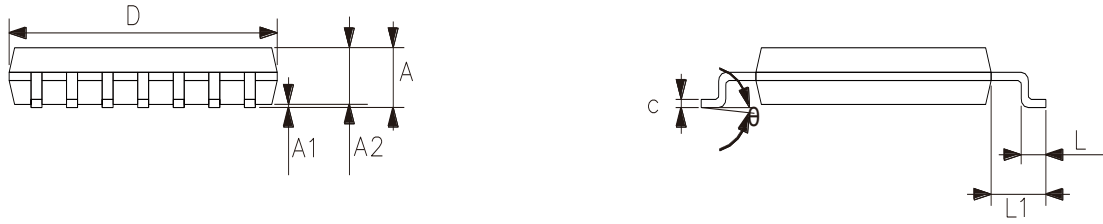

2023/12/A	Dimensions In Millimeters	
Symbol	Min	Max
A	—	1.20
A1	0.05	0.15
A2	0.80	1.05
b	0.19	0.30
c	0.09	0.20
D	4.90	5.10
E1	4.30	4.50
E	6.20	6.60
e	0.65	
L	0.45	0.75
L1	1.00	
θ	0°	8°



5.4、VQFN14

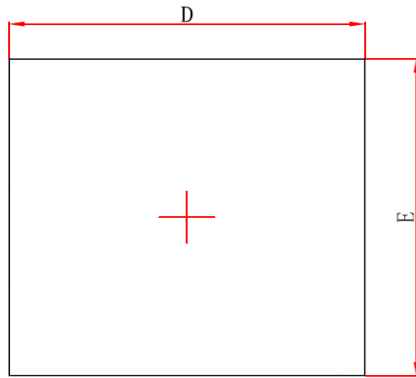

Top View

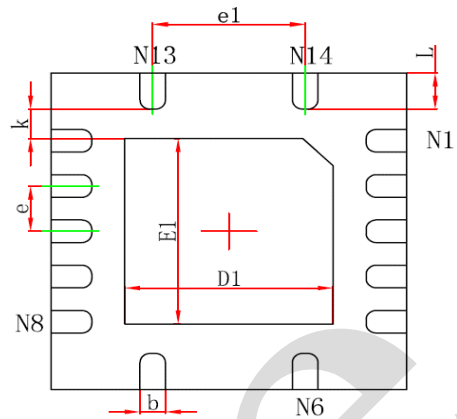

Bottom View

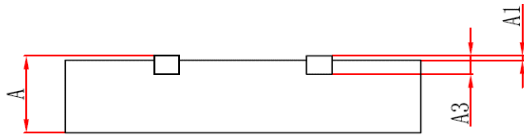

Side View

2024/08/A	Dimensions In Millimeters	
	Min	Max
A	0.70	0.90
A1	0	0.05
A3	0.203 REF	
D	3.424	3.576
E	3.424	3.576
D1	1.95	2.15
E1	1.95	2.15
k	0.20	—
b	0.20	0.30
e	0.50	
e1	1.50	
L	0.324	0.476



6、 Statements And Notes

6.1、 The name and content of Hazardous substances or Elements in the product

Part name	Hazardous substances or Elements									
	Lead and lead compounds	Mercury and mercury compounds	Cadmium and cadmium compounds	Hexavalent chromium compounds	Polybrominated biphenyls	Polybrominated biphenyl ethers	Dibutyl phthalate	Butylbenzyl phthalate	Di-2-ethylhexyl phthalate	Diisobutyl phthalate
Lead frame	○	○	○	○	○	○	○	○	○	○
Plastic resin	○	○	○	○	○	○	○	○	○	○
Chip	○	○	○	○	○	○	○	○	○	○
The lead	○	○	○	○	○	○	○	○	○	○
Plastic sheet installed	○	○	○	○	○	○	○	○	○	○
explanation	○: Indicates that the content of hazardous substances or elements in the detection limit of the following the SJ/T11363-2006 standard. ×: Indicates that the content of hazardous substances or elements exceeding the SJ/T11363-2006 Standard limit requirements.									

6.2、 Notes

We recommend you to read this chapter carefully before using this product.

The information in this chapter is provided for reference only and i-Core disclaims any express or implied warranties, including but not limited to applicability, special application or non-infringement of third party rights.

This product is not suitable for critical equipment such as life-saving, life-sustaining or safety equipment. It is also not suitable for applications that may result in personal injury, death, or serious property or environmental damage due to product malfunction or failure. I-Core will not be liable for any damages incurred by the customers at their own risk for such applications.

The customer is responsible for conducting all necessary tests i-Core's application to avoid failure in the application or the application of the customer's third party users. I-Core does not accept any liability.

The Company reserves the right to change or improve the information published in this chapter at any time. The information in this chapter are subject to change without notice. We recommend the customer to consult our sales staff before purchasing.

Please obtain related materials form i-Core's regular channels and we are not responsible for its content if it is provided by sources other than our company.

In case of any conflict between the Chinese and English version, the version is subject to the Chinese one.