



# **AiP74HC/HCT240**

## **Octal Buffer/Line Driver; 3-state; Inverting**

### **Product Specification**

**Specification Revision History:**

<b>Version</b>	<b>Date</b>	<b>Description</b>
2012-06-A1	2012-06	New
2023-04-B1	2023-04	Update the template



## 1、 General Description

The AiP74HC/HCT240 is an 8-bit inverting buffer/line driver with 3-state outputs. The device can be used as two 4-bit buffers or one 8-bit buffer. The device features two output enables ( $1\overline{OE}$  and  $2\overline{OE}$ ), each controlling four of the 3-state outputs. A HIGH on  $n\overline{OE}$  causes the outputs to assume a high-impedance OFF-state. Inputs include clamp diodes that enable the use of current limiting resistors to interface inputs to voltages in excess of  $V_{CC}$ .

### Features:

- Input levels:
  - For AiP74HC240: CMOS level
  - For AiP74HCT240: TTL level
- Inverting 3-state outputs
- Specified from  $-40^{\circ}\text{C}$  to  $+125^{\circ}\text{C}$
- Packaging information: DIP20/SOP20/TSSOP20

**Ordering Information:****Tube packing specifications:**

Part number	Packaging form	Marking code	Tube quantity	Boxed tube quantity	Boxed quantity	Notes
AiP74HC240DA20.TB	DIP20	74HC240	18 PCS/tube	40 tube/box	720 PCS/box	Dimensions of plastic enclosure: 26.3mm×6.4mm Pin spacing: 2.54mm
AiP74HCT240DA20.TB	DIP20	74HCT240	18 PCS/tube	40 tube/box	720 PCS/box	Dimensions of plastic enclosure: 26.3mm×6.4mm Pin spacing: 2.54mm
AiP74HC240SA20.TB	SOP20	74HC240	35 PCS/tube	80 tube/box	2800 PCS/box	Dimensions of plastic enclosure: 12.8mm×7.5mm Pin spacing: 1.27mm
AiP74HCT240SA20.TB	SOP20	74HCT240	35 PCS/tube	80 tube/box	2800 PCS/box	Dimensions of plastic enclosure: 12.8mm×7.5mm Pin spacing: 1.27mm
AiP74HC240TA20.TB	TSSOP20	74HC240	70 PCS/tube	200 tube/box	14000 PCS/box	Dimensions of plastic enclosure: 6.5mm×4.4mm Pin spacing: 0.65mm
AiP74HCT240TA20.TB	TSSOP20	74HCT240	70 PCS/tube	200 tube/box	14000 PCS/box	Dimensions of plastic enclosure: 6.5mm×4.4mm Pin spacing: 0.65mm



## Reel packing specifications:

Part number	Packaging form	Marking code	Reel quantity	Boxed reel quantity	Notes
AiP74HC240SA20.TR	SOP20	74HC240	2000PCS/reel	2000PCS/box	Dimensions of plastic enclosure: 12.8mm × 7.5mm Pin spacing: 1.27mm
AiP74HCT240SA20.TR	SOP20	74HCT240	2000PCS/reel	2000PCS/box	Dimensions of plastic enclosure: 12.8mm × 7.5mm Pin spacing: 1.27mm
AiP74HC240TA20.TR	TSSOP20	74HC240	4000PCS/reel	8000PCS/box	Dimensions of plastic enclosure: 6.5mm × 4.4mm Pin spacing: 0.65mm
AiP74HCT240TA20.TR	TSSOP20	74HCT240	4000PCS/reel	8000PCS/box	Dimensions of plastic enclosure: 6.5mm × 4.4mm Pin spacing: 0.65mm

Note: If the physical information is inconsistent with the ordering information, please refer to the actual product.



## 2、Block Diagram And Pin Description

### 2.1、Block Diagram

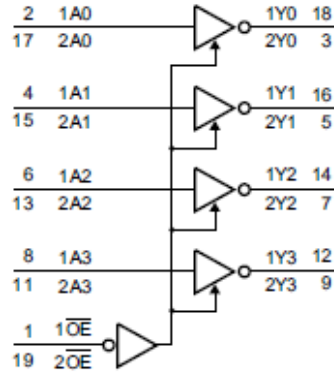

Figure 1. Logic symbol

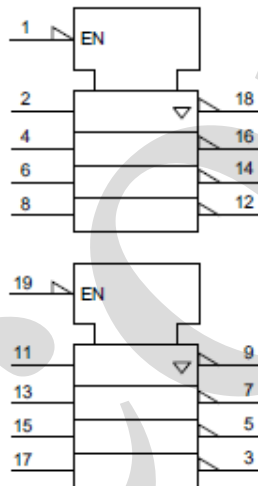

Figure 2. IEC logic symbol

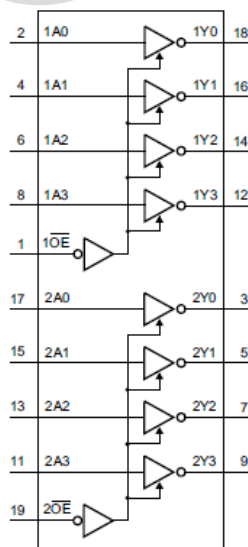
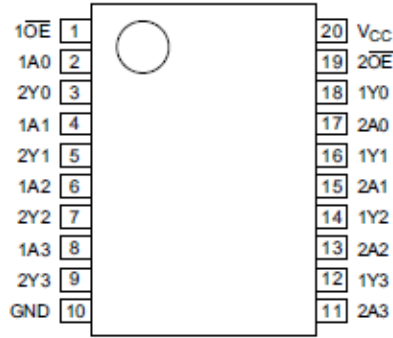

Figure 3. Functional diagram



## 2.2、Pin Configurations



## 2.3、Pin Description

Pin No.	Pin Name	Description
1	1OE	output enable input (active LOW)
2	1A0	data input
3	2Y0	bus output
4	1A1	data input
5	2Y1	bus output
6	1A2	data input
7	2Y2	bus output
8	1A3	data input
9	2Y3	bus output
10	GND	ground (0V)
11	2A3	data input
12	1Y3	bus output
13	2A2	data input
14	1Y2	bus output
15	2A1	data input
16	1Y1	bus output
17	2A0	data input
18	1Y0	bus output
19	2OE	output enable input (active LOW)
20	V <sub>CC</sub>	supply voltage

## 2.4、Function Table

Input		Output
nOE	nAn	nYn
L	L	H
L	H	L
H	X	Z

Note: H=HIGH voltage level; L=LOW voltage level; X=don't care; Z=high-impedance OFF-state.



## 3、Electrical Parameter

### 3.1、Absolute Maximum Ratings

(Voltages are referenced to GND(ground=0V), unless otherwise specified.)

Parameter	Symbol	Conditions	Min.	Max.	Unit
supply voltage	$V_{CC}$	-	-0.5	+7.0	V
input clamping current	$I_{IK}$	$V_I < -0.5V$ or $V_I > V_{CC}+0.5V$	-	$\pm 20$	mA
output clamping current	$I_{OK}$	$V_O < -0.5V$ or $V_O > V_{CC}+0.5V$	-	$\pm 20$	mA
output current	$I_O$	$-0.5V < V_O < V_{CC}+0.5V$	-	$\pm 35$	mA
supply current	$I_{CC}$	-	-	70	mA
ground current	$I_{GND}$	-	-70	-	mA
storage temperature	$T_{stg}$	-	-65	+150	°C
total power dissipation	$P_{tot}$	-	-	500	mW
Soldering temperature	$T_L$	10s	DIP	245	°C
			SOP/TSSOP	260	°C

### 3.2、Recommended Operating Conditions

Parameter	Symbol	Conditions	Min.	Typ.	Max.	Unit
<b>AiP74HC240</b>						
supply voltage	$V_{CC}$	-	2.0	5.0	6.0	V
input voltage	$V_I$	-	0	-	$V_{CC}$	V
output voltage	$V_O$	-	0	-	$V_{CC}$	V
input transition rise and fall rate	$\Delta t/\Delta V$	$V_{CC}=2.0V$	-	-	625	ns/V
		$V_{CC}=4.5V$	-	1.67	139	ns/V
		$V_{CC}=6.0V$	-	-	83	ns/V
ambient temperature	$T_{amb}$	-	-40	-	+125	°C
<b>AiP74HCT240</b>						
supply voltage	$V_{CC}$	-	4.5	5.0	5.5	V
input voltage	$V_I$	-	0	-	$V_{CC}$	V
output voltage	$V_O$	-	0	-	$V_{CC}$	V
input transition rise and fall rate	$\Delta t/\Delta V$	$V_{CC}=4.5V$	-	1.67	139	ns/V
ambient temperature	$T_{amb}$	-	-40	-	+125	°C



### 3.3、Electrical Characteristics

#### 3.3.1、DC Characteristics 1

( $T_{amb}=25^{\circ}\text{C}$ , voltages are referenced to GND (ground=0V), unless otherwise specified.)

Parameter	Symbol	Conditions	Min.	Typ.	Max.	Unit	
<b>AiP74HC240</b>							
HIGH-level input voltage	$V_{IH}$	$V_{CC}=2.0\text{V}$	1.5	1.2	-	V	
		$V_{CC}=4.5\text{V}$	3.15	2.4	-	V	
		$V_{CC}=6.0\text{V}$	4.2	3.2	-	V	
LOW-level input voltage	$V_{IL}$	$V_{CC}=2.0\text{V}$	-	0.8	0.5	V	
		$V_{CC}=4.5\text{V}$	-	2.1	1.35	V	
		$V_{CC}=6.0\text{V}$	-	2.8	1.8	V	
HIGH-level output voltage	$V_{OH}$	$V_I = V_{IH} \text{ or } V_{IL}$	$I_O=-20\mu\text{A}; V_{CC}=2.0\text{V}$	1.9	2.0	-	V
			$I_O=-20\mu\text{A}; V_{CC}=4.5\text{V}$	4.4	4.5	-	V
			$I_O=-20\mu\text{A}; V_{CC}=6.0\text{V}$	5.9	6.0	-	V
			$I_O=-6.0\text{mA}; V_{CC}=4.5\text{V}$	3.98	4.32	-	V
			$I_O=-7.8\text{mA}; V_{CC}=6.0\text{V}$	5.48	5.81	-	V
LOW-level output voltage	$V_{OL}$	$V_I = V_{IH} \text{ or } V_{IL}$	$I_O=20\mu\text{A}; V_{CC}=2.0\text{V}$	-	0	0.1	V
			$I_O=20\mu\text{A}; V_{CC}=4.5\text{V}$	-	0	0.1	V
			$I_O=20\mu\text{A}; V_{CC}=6.0\text{V}$	-	0	0.1	V
			$I_O=6.0\text{mA}; V_{CC}=4.5\text{V}$	-	0.15	0.26	V
			$I_O=7.8\text{mA}; V_{CC}=6.0\text{V}$	-	0.16	0.26	V
input leakage current	$I_I$	$V_I=V_{CC} \text{ or } \text{GND}; V_{CC}=6.0\text{V}$	-	-	$\pm 1.0$	$\mu\text{A}$	
OFF-state output current	$I_{OZ}$	$V_I=V_{IH} \text{ or } V_{IL}; V_{CC}=6.0\text{V}; V_O=V_{CC} \text{ or } \text{GND}$	-	-	$\pm 1.0$	$\mu\text{A}$	
supply current	$I_{CC}$	$V_I=V_{CC} \text{ or } \text{GND}; I_O=0\text{A}; V_{CC}=6.0\text{V}$	-	-	8.0	$\mu\text{A}$	
input capacitance	$C_I$	-	-	3.5	-	pF	
<b>AiP74HCT240</b>							
HIGH-level input voltage	$V_{IH}$	$V_{CC}=4.5\text{V to } 5.5\text{V}$	2.0	1.6	-	V	
LOW-level input voltage	$V_{IL}$	$V_{CC}=4.5\text{V to } 5.5\text{V}$	-	1.2	0.8	V	
HIGH-level output voltage	$V_{OH}$	$V_I = V_{IH} \text{ or } V_{IL}; V_{CC}=4.5\text{V}$	$I_O=-20\mu\text{A}$	4.4	4.5	-	V
			$I_O=-6.0\text{mA}$	3.98	4.32	-	V
LOW-level output voltage	$V_{OL}$	$V_I = V_{IH} \text{ or } V_{IL}; V_{CC}=4.5\text{V}$	$I_O=20\mu\text{A}$	-	0	0.1	V
			$I_O=6.0\text{mA}$	-	0.16	0.26	V
input leakage current	$I_I$	$V_I=V_{CC} \text{ or } \text{GND}; V_{CC}=5.5\text{V}$	-	-	$\pm 1.0$	$\mu\text{A}$	
OFF-state output current	$I_{OZ}$	$V_I=V_{IH} \text{ or } V_{IL}; V_{CC}=5.5\text{V}; V_O=V_{CC} \text{ or } \text{GND}$	-	-	$\pm 1.0$	$\mu\text{A}$	
supply current	$I_{CC}$	$V_I=V_{CC} \text{ or } \text{GND}; I_O=0\text{A}; V_{CC}=5.5\text{V}$	-	-	8.0	$\mu\text{A}$	
additional supply current	$\Delta I_{CC}$	per input pin; $V_I=V_{CC}-2.1\text{V};$ other inputs at $V_{CC}$ or GND; $V_{CC}=4.5\text{V to } 5.5\text{V}; I_O=0\text{A}$	nAn or inputs	-	-	540	$\mu\text{A}$
			nOE input	-	-	252	$\mu\text{A}$
input	$C_I$	-	-	3.5	-	pF	



capacitance					
-------------	--	--	--	--	--

### 3.3.2、DC Characteristics 2

( $T_{amb}=-40^{\circ}\text{C}$  to  $+85^{\circ}\text{C}$ , voltages are referenced to GND (ground=0V), unless otherwise specified.)

Parameter	Symbol	Conditions	Min.	Typ.	Max.	Unit	
<b>AiP74HC240</b>							
HIGH-level input voltage	$V_{IH}$	$V_{CC}=2.0\text{V}$	1.5	-	-	V	
		$V_{CC}=4.5\text{V}$	3.15	-	-	V	
		$V_{CC}=6.0\text{V}$	4.2	-	-	V	
LOW-level input voltage	$V_{IL}$	$V_{CC}=2.0\text{V}$	-	-	0.5	V	
		$V_{CC}=4.5\text{V}$	-	-	1.35	V	
		$V_{CC}=6.0\text{V}$	-	-	1.8	V	
HIGH-level output voltage	$V_{OH}$	$V_I = V_{IH} \text{ or } V_{IL}$	$I_O=-20\mu\text{A}; V_{CC}=2.0\text{V}$	1.9	-	-	V
			$I_O=-20\mu\text{A}; V_{CC}=4.5\text{V}$	4.4	-	-	V
			$I_O=-20\mu\text{A}; V_{CC}=6.0\text{V}$	5.9	-	-	V
			$I_O=-6.0\text{mA}; V_{CC}=4.5\text{V}$	3.84	-	-	V
			$I_O=-7.8\text{mA}; V_{CC}=6.0\text{V}$	5.34	-	-	V
LOW-level output voltage	$V_{OL}$	$V_I = V_{IH} \text{ or } V_{IL}$	$I_O=20\mu\text{A}; V_{CC}=2.0\text{V}$	-	-	0.1	V
			$I_O=20\mu\text{A}; V_{CC}=4.5\text{V}$	-	-	0.1	V
			$I_O=20\mu\text{A}; V_{CC}=6.0\text{V}$	-	-	0.1	V
			$I_O=6.0\text{mA}; V_{CC}=4.5\text{V}$	-	-	0.33	V
			$I_O=7.8\text{mA}; V_{CC}=6.0\text{V}$	-	-	0.33	V
input leakage current	$I_I$	$V_I=V_{CC} \text{ or } \text{GND}; V_{CC}=6.0\text{V}$	-	-	$\pm 1.0$	$\mu\text{A}$	
OFF-state output current	$I_{OZ}$	$V_I=V_{IH} \text{ or } V_{IL}; V_{CC}=6.0\text{V}; V_O=V_{CC} \text{ or } \text{GND}$	-	-	$\pm 5.0$	$\mu\text{A}$	
supply current	$I_{CC}$	$V_I=V_{CC} \text{ or } \text{GND}; I_O=0\text{A}; V_{CC}=6.0\text{V}$	-	-	80	$\mu\text{A}$	
<b>AiP74HCT240</b>							
HIGH-level input voltage	$V_{IH}$	$V_{CC}=4.5\text{V to } 5.5\text{V}$	2.0	-	-	V	
LOW-level input voltage	$V_{IL}$	$V_{CC}=4.5\text{V to } 5.5\text{V}$	-	-	0.8	V	
HIGH-level output voltage	$V_{OH}$	$V_I = V_{IH} \text{ or } V_{IL}; V_{CC}=4.5\text{V}$	$I_O=-20\mu\text{A}$	4.4	-	-	V
			$I_O=-6.0\text{mA}$	3.84	-	-	V
LOW-level output voltage	$V_{OL}$	$V_I = V_{IH} \text{ or } V_{IL}; V_{CC}=4.5\text{V}$	$I_O=20\mu\text{A}$	-	-	0.1	V
			$I_O=6.0\text{mA}$	-	-	0.33	V
input leakage current	$I_I$	$V_I=V_{CC} \text{ or } \text{GND}; V_{CC}=5.5\text{V}$	-	-	$\pm 1.0$	$\mu\text{A}$	
OFF-state output current	$I_{OZ}$	$V_I=V_{IH} \text{ or } V_{IL}; V_{CC}=5.5\text{V}; V_O=V_{CC} \text{ or } \text{GND}$	-	-	$\pm 5.0$	$\mu\text{A}$	
supply current	$I_{CC}$	$V_I=V_{CC} \text{ or } \text{GND}; I_O=0\text{A}; V_{CC}=5.5\text{V}$	-	-	80	$\mu\text{A}$	
additional supply current	$\Delta I_{CC}$	per input pin; $V_I=V_{CC}-2.1\text{V};$ other inputs at $V_{CC}$ or GND; $V_{CC}=4.5\text{V}$ to $5.5\text{V}; I_O=0\text{A}$	nAn or inputs	-	-	675	$\mu\text{A}$
			nOE input	-	-	315	$\mu\text{A}$



### 3.3.3、DC Characteristics 3

( $T_{amb} = -40^{\circ}\text{C}$  to  $+125^{\circ}\text{C}$ , voltages are referenced to GND (ground=0V), unless otherwise specified.)

Parameter	Symbol	Conditions	Min.	Typ.	Max.	Unit	
<b>AiP74HC240</b>							
HIGH-level input voltage	$V_{IH}$	$V_{CC}=2.0\text{V}$	1.5	-	-	V	
		$V_{CC}=4.5\text{V}$	3.15	-	-	V	
		$V_{CC}=6.0\text{V}$	4.2	-	-	V	
LOW-level input voltage	$V_{IL}$	$V_{CC}=2.0\text{V}$	-	-	0.5	V	
		$V_{CC}=4.5\text{V}$	-	-	1.35	V	
		$V_{CC}=6.0\text{V}$	-	-	1.8	V	
HIGH-level output voltage	$V_{OH}$	$V_I = V_{IH} \text{ or } V_{IL}$	$I_O = -20\mu\text{A}; V_{CC}=2.0\text{V}$	1.9	-	-	V
			$I_O = -20\mu\text{A}; V_{CC}=4.5\text{V}$	4.4	-	-	V
			$I_O = -20\mu\text{A}; V_{CC}=6.0\text{V}$	5.9	-	-	V
			$I_O = -6.0\text{mA}; V_{CC}=4.5\text{V}$	3.7	-	-	V
			$I_O = -7.8\text{mA}; V_{CC}=6.0\text{V}$	5.2	-	-	V
LOW-level output voltage	$V_{OL}$	$V_I = V_{IH} \text{ or } V_{IL}$	$I_O = 20\mu\text{A}; V_{CC}=2.0\text{V}$	-	-	0.1	V
			$I_O = 20\mu\text{A}; V_{CC}=4.5\text{V}$	-	-	0.1	V
			$I_O = 20\mu\text{A}; V_{CC}=6.0\text{V}$	-	-	0.1	V
			$I_O = 6.0\text{mA}; V_{CC}=4.5\text{V}$	-	-	0.4	V
			$I_O = 7.8\text{mA}; V_{CC}=6.0\text{V}$	-	-	0.4	V
input leakage current	$I_I$	$V_I = V_{CC} \text{ or } \text{GND}; V_{CC}=6.0\text{V}$	-	-	$\pm 1.0$	$\mu\text{A}$	
OFF-state output current	$I_{OZ}$	$V_I = V_{IH} \text{ or } V_{IL}; V_{CC}=6.0\text{V}; V_O = V_{CC} \text{ or } \text{GND}$	-	-	$\pm 10$	$\mu\text{A}$	
supply current	$I_{CC}$	$V_I = V_{CC} \text{ or } \text{GND}; I_O = 0\text{A}; V_{CC}=6.0\text{V}$	-	-	160	$\mu\text{A}$	
<b>AiP74HCT240</b>							
HIGH-level input voltage	$V_{IH}$	$V_{CC}=4.5\text{V to } 5.5\text{V}$	2.0	-	-	V	
LOW-level input voltage	$V_{IL}$	$V_{CC}=4.5\text{V to } 5.5\text{V}$	-	-	0.8	V	
HIGH-level output voltage	$V_{OH}$	$V_I = V_{IH} \text{ or } V_{IL}; V_{CC}=4.5\text{V}$	$I_O = -20\mu\text{A}$	4.4	-	-	V
			$I_O = -6.0\text{mA}$	3.7	-	-	V
LOW-level output voltage	$V_{OL}$	$V_I = V_{IH} \text{ or } V_{IL}; V_{CC}=4.5\text{V}$	$I_O = 20\mu\text{A}$	-	-	0.1	V
			$I_O = 6.0\text{mA}$	-	-	0.4	V
input leakage current	$I_I$	$V_I = V_{CC} \text{ or } \text{GND}; V_{CC}=5.5\text{V}$	-	-	$\pm 1.0$	$\mu\text{A}$	
OFF-state output current	$I_{OZ}$	$V_I = V_{IH} \text{ or } V_{IL}; V_{CC}=5.5\text{V}; V_O = V_{CC} \text{ or } \text{GND}$	-	-	$\pm 10$	$\mu\text{A}$	
supply current	$I_{CC}$	$V_I = V_{CC} \text{ or } \text{GND}; I_O = 0\text{A}; V_{CC}=5.5\text{V}$	-	-	160	$\mu\text{A}$	
additional supply current	$\Delta I_{CC}$	per input pin; $V_I = V_{CC} - 2.1\text{V};$ other inputs at $V_{CC}$ or GND; $V_{CC}=4.5\text{V to } 5.5\text{V}; I_O=0\text{A}$	nAn or inputs	-	-	735	$\mu\text{A}$
			nOE input	-	-	343	$\mu\text{A}$



### 3.3.4、AC Characteristics 1

( $T_{amb}=25^{\circ}C$ , voltages are referenced to GND (ground=0V), unless otherwise specified.)

Parameter	Symbol	Conditions	Min.	Typ.	Max.	Unit	
<b>AiP74HC240</b>							
nAn to nYn propagation delay	$t_{pd}$	see Figure 5	$V_{CC}=2.0V$	-	30	100	ns
			$V_{CC}=4.5V$	-	11	20	ns
			$V_{CC}=5.0V; C_L=15pF$	-	9	-	ns
			$V_{CC}=6.0V$	-	9	17	ns
nOE to nYn enable time	$t_{en}$	see Figure 6	$V_{CC}=2.0V$	-	39	150	ns
			$V_{CC}=4.5V$	-	14	30	ns
			$V_{CC}=6.0V$	-	11	26	ns
nOE to nYn disable time	$t_{dis}$	see Figure 6	$V_{CC}=2.0V$	-	41	150	ns
			$V_{CC}=4.5V$	-	15	30	ns
			$V_{CC}=6.0V$	-	12	26	ns
transition time	$t_t$	see Figure 5	$V_{CC}=2.0V$	-	14	60	ns
			$V_{CC}=4.5V$	-	5	12	ns
			$V_{CC}=6.0V$	-	4	10	ns
power dissipation capacitance	$C_{PD}$	per buffer; $V_I=GND$ to $V_{CC}$	-	30	-	pF	
<b>AiP74HCT240</b>							
nAn to nYn propagation delay	$t_{pd}$	see Figure 5	$V_{CC}=4.5V$	-	11	20	ns
			$V_{CC}=5.0V; C_L=15pF$	-	9	-	ns
nOE to nYn enable time	$t_{en}$	$V_{CC}=4.5V$ ; see Figure 6	-	13	30	ns	
nOE to nYn disable time	$t_{dis}$	$V_{CC}=4.5V$ ; see Figure 6	-	13	25	ns	
transition time	$t_t$	$V_{CC}=4.5V$ ; see Figure 5	-	5	12	ns	
power dissipation capacitance	$C_{PD}$	per buffer; $V_I=GND$ to $V_{CC}-1.5V$	-	30	-	pF	

Note:

- [1]  $t_{pd}$  is the same as  $t_{PLH}$  and  $t_{PHL}$ .
- [2]  $t_{en}$  is the same as  $t_{PZL}$  and  $t_{PZH}$ .
- [3]  $t_{dis}$  is the same as  $t_{PLZ}$  and  $t_{PHZ}$ .
- [4]  $t_t$  is the same as  $t_{THL}$  and  $t_{TLH}$ .
- [5]  $C_{PD}$  is used to determine the dynamic power dissipation ( $P_D$  in uW).

$$P_D = C_{PD} \times V_{CC}^2 \times f_i \times N + \sum (C_L \times V_{CC}^2 \times f_o) \text{ where:}$$

$f_i$ =input frequency in MHz;

$f_o$ =output frequency in MHz;

$C_L$ =output load capacitance in pF;

$V_{CC}$ =supply voltage in V;

$N$ =number of inputs switching;

$\sum (C_L \times V_{CC}^2 \times f_o)$ =sum of outputs.



### 3.3.5、AC Characteristics 2

( $T_{amb}=-40^{\circ}\text{C}$  to  $+85^{\circ}\text{C}$ , voltages are referenced to GND (ground=0V), unless otherwise specified.)

Parameter	Symbol	Conditions	Min.	Typ.	Max.	Unit	
<b>AiP74HC240</b>							
nAn to nYn propagation delay	$t_{pd}$	see Figure 5	$V_{CC}=2.0\text{V}$	-	-	125	ns
			$V_{CC}=4.5\text{V}$	-	-	25	ns
			$V_{CC}=6.0\text{V}$	-	-	21	ns
nOE to nYn enable time	$t_{en}$	see Figure 6	$V_{CC}=2.0\text{V}$	-	-	190	ns
			$V_{CC}=4.5\text{V}$	-	-	38	ns
			$V_{CC}=6.0\text{V}$	-	-	33	ns
nOE to nYn disable time	$t_{dis}$	see Figure 6	$V_{CC}=2.0\text{V}$	-	-	190	ns
			$V_{CC}=4.5\text{V}$	-	-	38	ns
			$V_{CC}=6.0\text{V}$	-	-	33	ns
transition time	$t_t$	see Figure 5	$V_{CC}=2.0\text{V}$	-	-	75	ns
			$V_{CC}=4.5\text{V}$	-	-	15	ns
			$V_{CC}=6.0\text{V}$	-	-	13	ns
<b>AiP74HCT240</b>							
nAn to nYn propagation delay	$t_{pd}$	see Figure 5	$V_{CC}=4.5\text{V}$	-	-	25	ns
nOE to nYn enable time	$t_{en}$	$V_{CC}=4.5\text{V}$ ; see Figure 6		-	-	38	ns
nOE to nYn disable time	$t_{dis}$	$V_{CC}=4.5\text{V}$ ; see Figure 6		-	-	31	ns
transition time	$t_t$	$V_{CC}=4.5\text{V}$ ; see Figure 5		-	-	15	ns

Note:

[1]  $t_{pd}$  is the same as  $t_{PLH}$  and  $t_{PHL}$ .

[2]  $t_{en}$  is the same as  $t_{PZL}$  and  $t_{PZH}$ .

[3]  $t_{dis}$  is the same as  $t_{PLZ}$  and  $t_{PHZ}$ .

[4]  $t_t$  is the same as  $t_{THL}$  and  $t_{TLH}$ .



### 3.3.6. AC Characteristics 3

( $T_{amb} = -40^{\circ}\text{C}$  to  $+125^{\circ}\text{C}$ , voltages are referenced to GND (ground=0V), unless otherwise specified.)

Parameter	Symbol	Conditions	Min.	Typ.	Max.	Unit	
<b>AiP74HC240</b>							
nAn to nYn propagation delay	$t_{pd}$	see Figure 5	$V_{CC}=2.0\text{V}$	-	-	150	ns
			$V_{CC}=4.5\text{V}$	-	-	30	ns
			$V_{CC}=6.0\text{V}$	-	-	26	ns
n $\overline{\text{OE}}$ to nYn enable time	$t_{en}$	see Figure 6	$V_{CC}=2.0\text{V}$	-	-	225	ns
			$V_{CC}=4.5\text{V}$	-	-	45	ns
			$V_{CC}=6.0\text{V}$	-	-	38	ns
n $\overline{\text{OE}}$ to nYn disable time	$t_{dis}$	see Figure 6	$V_{CC}=2.0\text{V}$	-	-	225	ns
			$V_{CC}=4.5\text{V}$	-	-	45	ns
			$V_{CC}=6.0\text{V}$	-	-	38	ns
transition time	$t_t$	see Figure 5	$V_{CC}=2.0\text{V}$	-	-	90	ns
			$V_{CC}=4.5\text{V}$	-	-	18	ns
			$V_{CC}=6.0\text{V}$	-	-	15	ns
<b>AiP74HCT240</b>							
nAn to nYn propagation delay	$t_{pd}$	see Figure 5	$V_{CC}=4.5\text{V}$	-	-	30	ns
n $\overline{\text{OE}}$ to nYn enable time	$t_{en}$	$V_{CC}=4.5\text{V}$ ; see Figure 6		-	-	45	ns
n $\overline{\text{OE}}$ to nYn disable time	$t_{dis}$	$V_{CC}=4.5\text{V}$ ; see Figure 6		-	-	38	ns
transition time	$t_t$	$V_{CC}=4.5\text{V}$ ; see Figure 5		-	-	18	ns

Note:

- [1]  $t_{pd}$  is the same as  $t_{PLH}$  and  $t_{PHL}$ .
- [2]  $t_{en}$  is the same as  $t_{PZL}$  and  $t_{PZH}$ .
- [3]  $t_{dis}$  is the same as  $t_{PLZ}$  and  $t_{PHZ}$ .
- [4]  $t_t$  is the same as  $t_{THL}$  and  $t_{TLH}$ .



### 4、 Testing Circuit

#### 4.1、 AC Testing Circuit

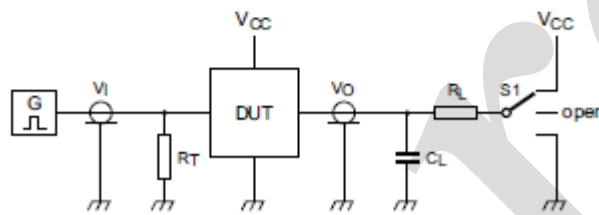
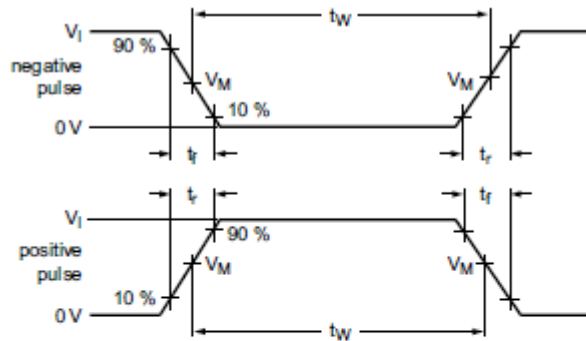

Figure 4. Test circuit for measuring switching times

Definitions for test circuit:

$R_L$ =Load resistance.

$C_L$ =Load capacitance including jig and probe capacitance.

$R_T$ =Termination resistance should be equal to the output impedance  $Z_o$  of the pulse generator.

S1=Test selection switch.

#### 4.2、 AC Testing Waveforms

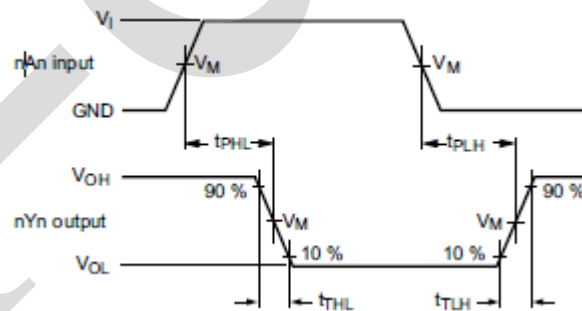

Figure 5. Input (nAn) to output (nYn) propagation delays and output transition times

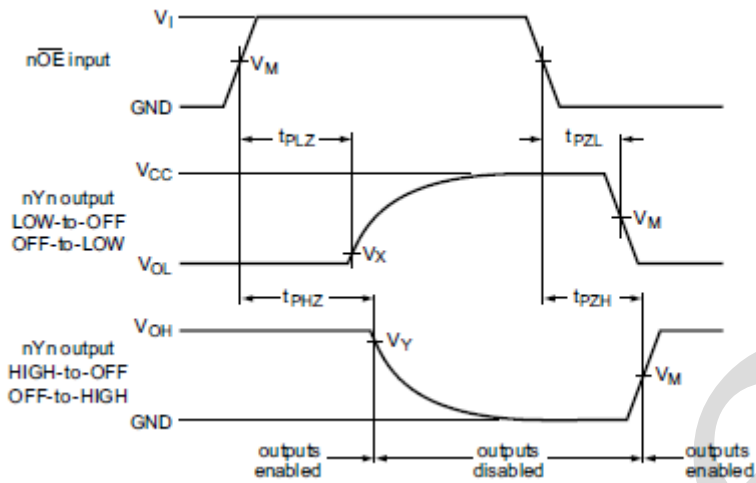

Figure 6. 3-state enable and disable times

**4.3、 Measurement Points**

Type	Input	Output		
	$V_M$	$V_M$	$V_X$	$V_Y$
AiP74HC240	$0.5 \times V_{CC}$	$0.5 \times V_{CC}$	$0.1 \times V_{CC}$	$0.9 \times V_{CC}$
AiP74HCT240	1.3V	1.3V	$0.1 \times V_{CC}$	$0.9 \times V_{CC}$

**4.4、 Test Data**

Type	Input		Load		S1 position		
	$V_I$	$t_r, t_f$	$C_L$	$R_L$	$t_{PHL}, t_{PLH}$	$t_{PZH}, t_{PHZ}$	$t_{PZL}, t_{PLZ}$
AiP74HC240	$V_{CC}$	6ns	15pF, 50pF	1kΩ	open	GND	$V_{CC}$
AiP74HCT240	3V	6ns	15pF, 50pF	1kΩ	open	GND	$V_{CC}$



## 5、Package Information

### 5.1、DIP20

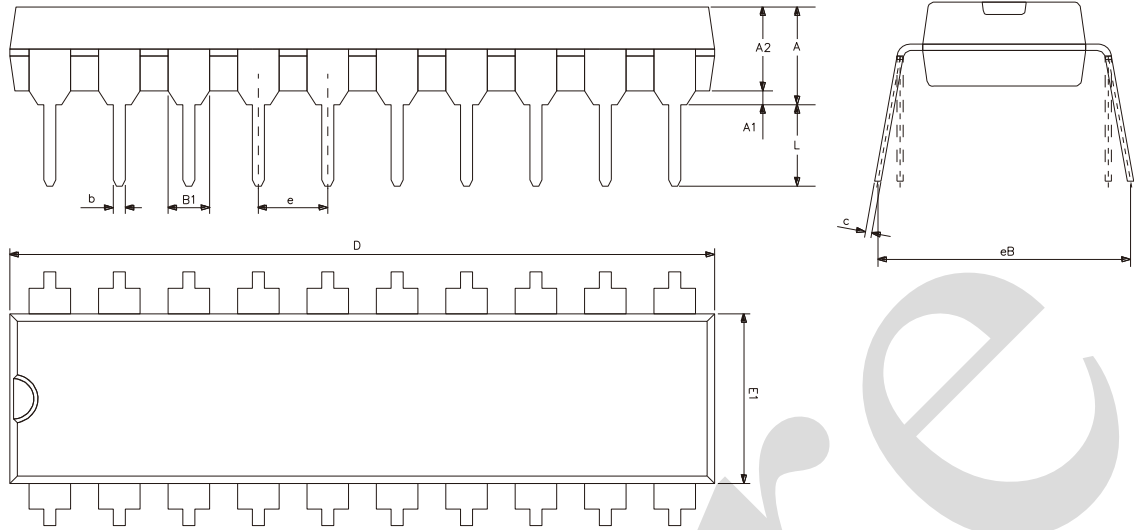

Symbol	Dimensions (mm)	
	Min.	Max.
A	3.60	5.33
A1	0.51	-
A2	3.20	3.60
b	0.36	0.53
B1	1.52	
c	0.204	0.36
D	25.70	26.54
E1	6.20	6.75
e	2.54	
eB	7.62	9.30
L	3.00	3.60



## 5.2、SOP20

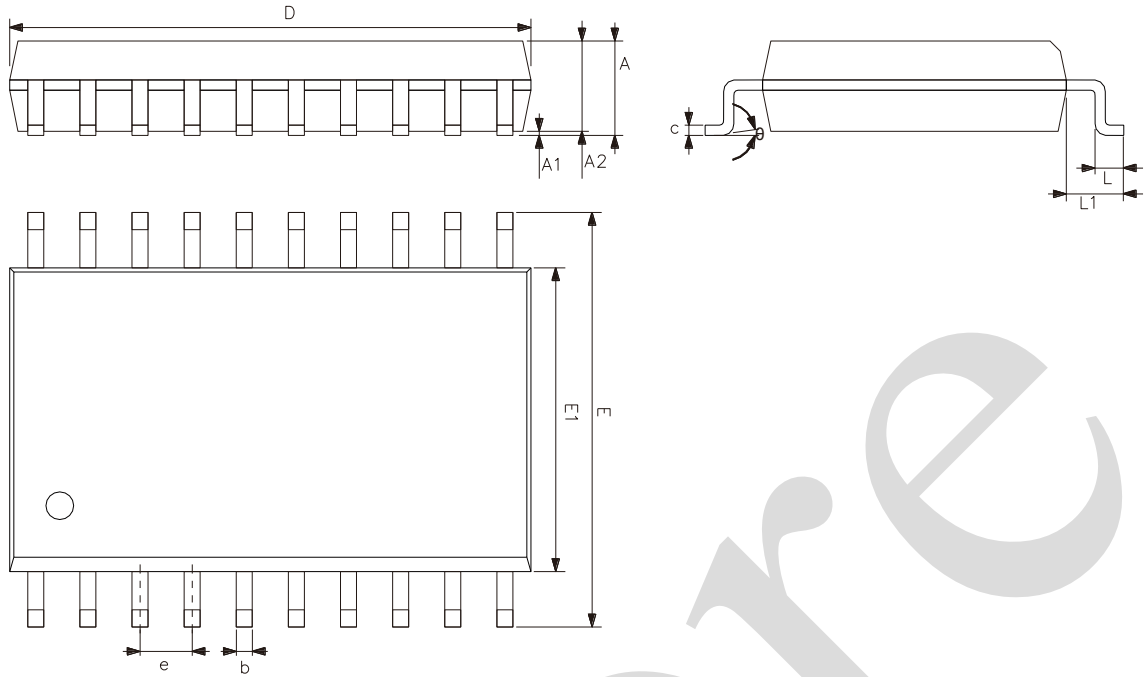

Symbol	Dimensions (mm)	
	Min.	Max.
A	2.47	2.65
A1	0.05	0.30
A2	2.20	2.44
b	0.35	0.50
c	0.15	0.30
D	12.54	12.94
E	10.00	10.60
E1	7.30	7.70
e	1.27	
L	0.40	1.05
L1	1.30	1.50
$\theta$	0°	8°



## 5.3、TSSOP20

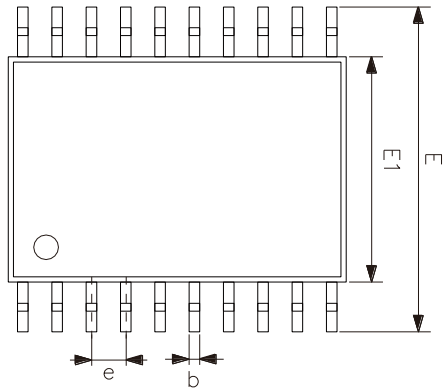
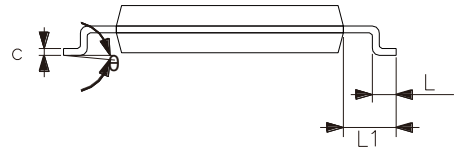
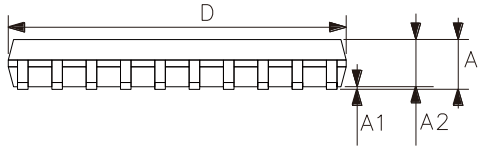

Symbol	Dimensions (mm)	
	Min.	Max.
A	-	1.20
A1	0.05	0.15
A2	0.80	1.05
b	0.19	0.30
c	0.09	0.20
D	6.40	6.60
E1	4.30	4.50
E	6.20	6.60
e	0.65	
L	0.45	0.75
L1	1.00	
$\theta$	0°	8°



## 6、 Statements And Notes

### 6.1、 The name and content of Hazardous substances or Elements in the product

Part name	Hazardous substances or Elements									
	Lead and lead compounds	Mercury and mercury compounds	Cadmium and cadmium compounds	Hexavalent chromium compounds	Polybrominated biphenyls	Polybrominated biphenyl ethers	Dibutyl phthalate	Butylbenzyl phthalate	Di-2-ethylhexyl phthalate	Diisobutyl phthalate
Lead frame	○	○	○	○	○	○	○	○	○	○
Plastic resin	○	○	○	○	○	○	○	○	○	○
Chip	○	○	○	○	○	○	○	○	○	○
The lead	○	○	○	○	○	○	○	○	○	○
Plastic sheet installed	○	○	○	○	○	○	○	○	○	○
explanation	○: Indicates that the content of hazardous substances or elements in the detection limit of the following the SJ/T11363-2006 standard. ×: Indicates that the content of hazardous substances or elements exceeding the SJ/T11363-2006 Standard limit requirements.									

### 6.2、 Notes

We Recommend you to read this chapter carefully before using this product.

The information in this chapter is provided for reference only and i-Core disclaims any express or implied warranties, including but not limited to applicability, special application or non-infringement of third party rights.

This product is not suitable for critical equipment such as life-saving, life-sustaining or safety equipment. It is also not suitable for applications that may result in personal injury, death, or serious property or environmental damage due to product malfunction or failure. I-Core will not be liable for any damages incurred by the customers at their own risk for such applications.

The customer is responsible for conducting all necessary tests i-Core's application to avoid failure in the application or the application of the customer's third party users. I-Core does not accept any liability.

The Company reserves the right to change or improve the information published in this chapter at any time.

The information in this chapter are subject to change without notice. We recommend the customer to consult our sales staff before purchasing.

Please obtain related materials form i-Core's regular channels and we are not responsible for its content if it is provided by sources other than our company.

In case of any conflict between the Chinese and English version, the version is subject to the Chinese one.