



## **1. GENERAL DESCRIPTION**

The W27C512 is a high speed, low power Electrically Erasable and Programmable Read Only Memory organized as  $65536 \times 8$  bits that operates on a single 5 volt power supply. The W27C512 provides an electrical chip erase function.

## **2. FEATURES**

- High speed access time: 45/70/90/120 nS (max.)
- Read operating current: 30 mA (max.)
- Erase/Programming operating current: 30 mA (max.)
- Standby current: 1 mA (max.)
- Single 5V power supply
- +14V erase/+12V programming voltage
- Fully static operation
- All inputs and outputs directly TTL/CMOS compatible
- Three-state outputs
- Available packages: 28-pin 600 mil DIP, 330 mil 32-pin PLCC



3. PIN CONFIGURATIONS

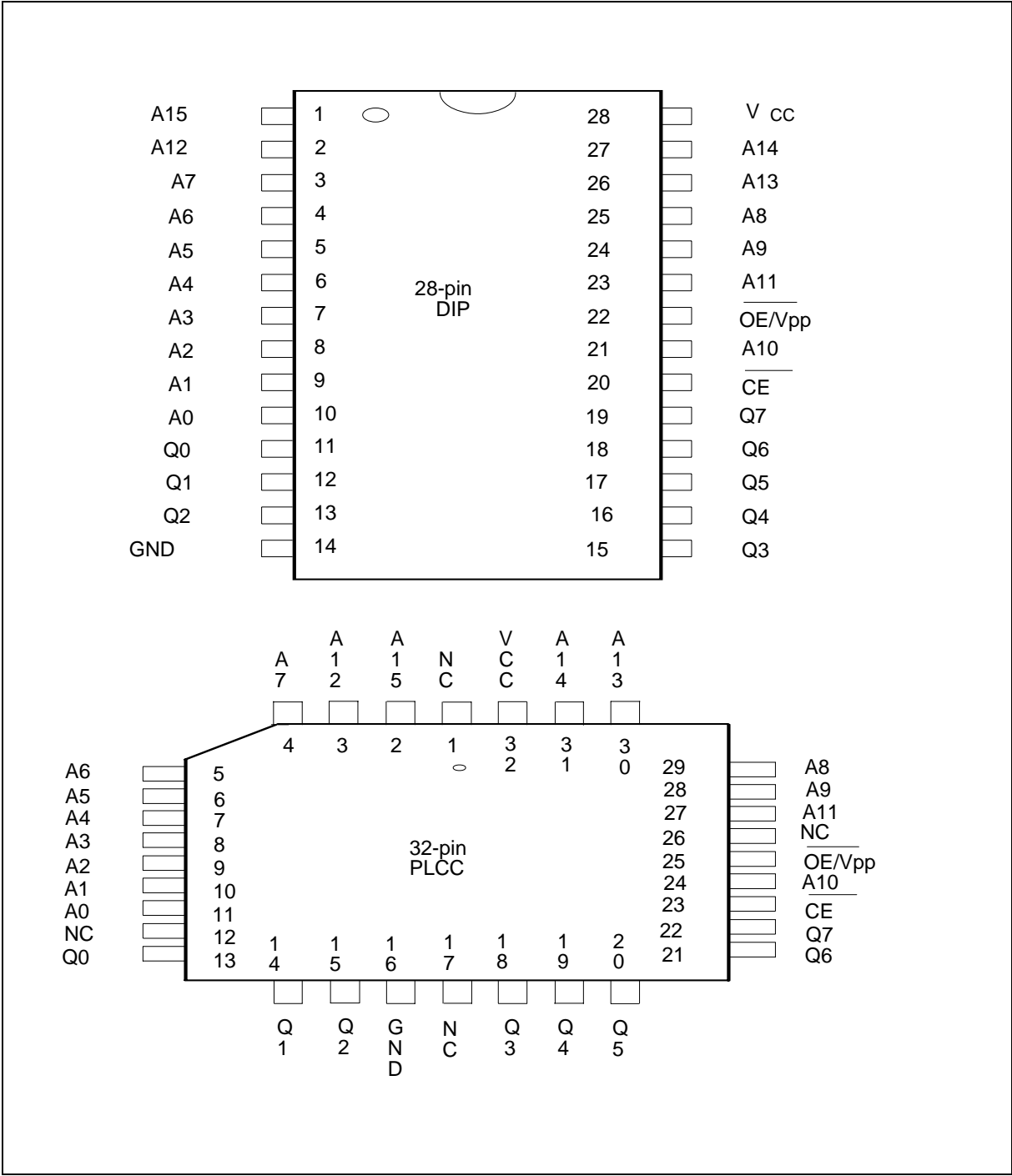



4. BLOCK DIAGRAM

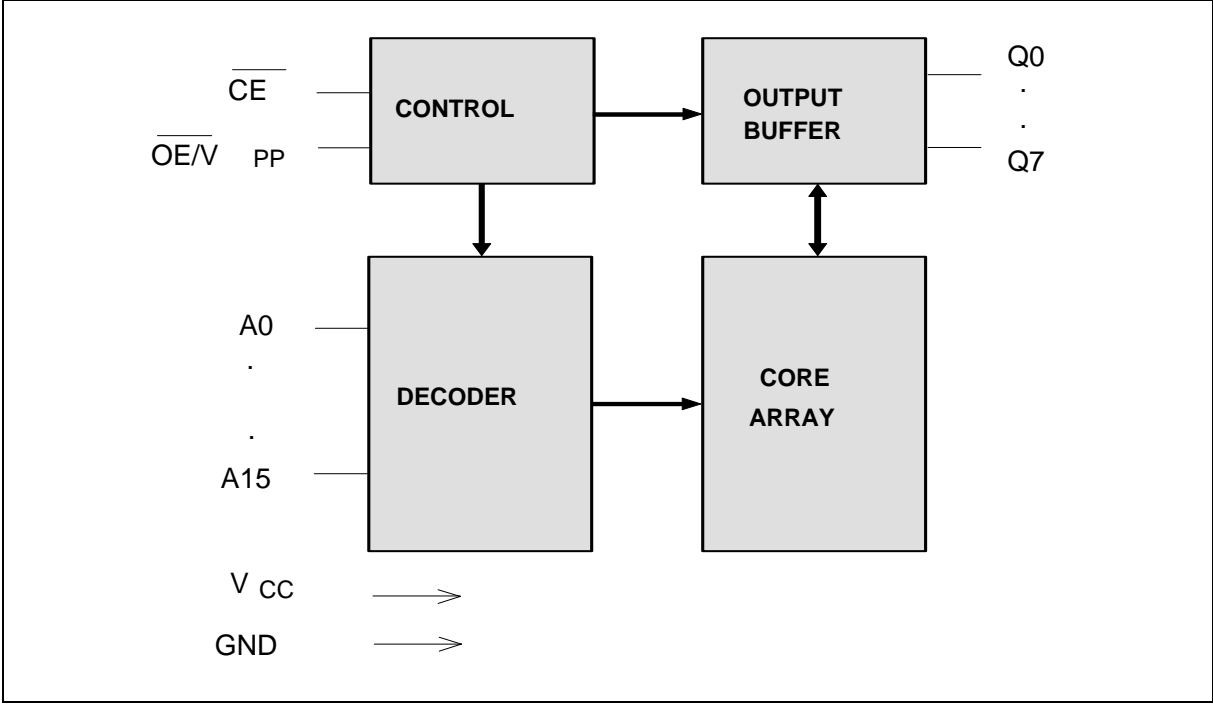

5. PIN DESCRIPTION

SYMBOL	DESCRIPTION
A0-A15	Address Inputs
Q0-Q7	Data Inputs/Outputs
$\overline{CE}$	Chip Enable
$\overline{OE/V_{PP}}$	Output Enable, Program/Erase Supply Voltage
VCC	Power Supply
GND	Ground
NC	No Connection



## 6. FUNCTIONAL DESCRIPTION

### Read Mode

Like conventional UVEPROMs, the W27C512 has two control functions, both of which produce data at the outputs.  $\overline{CE}$  is for power control and chip select.  $\overline{OE}/V_{PP}$  controls the output buffer to gate data to the output pins. When addresses are stable, the address access time ( $T_{ACC}$ ) is equal to the delay from  $\overline{CE}$  to output ( $T_{CE}$ ), and data are available at the outputs  $T_{OE}$  after the falling edge of  $\overline{OE}/V_{PP}$ , if  $T_{ACC}$  and  $T_{CE}$  timings are met.

### Erase Mode

The erase operation is the only way to change data from "0" to "1." Unlike conventional UVEPROMs, which use ultraviolet light to erase the contents of the entire chip (a procedure that requires up to half an hour), the W27C512 uses electrical erasure. Generally, the chip can be erased within 100 mS by using an EPROM writer with a special erase algorithm.

Erase mode is entered when  $\overline{OE}/V_{PP}$  is raised to  $V_{PE}$  (14V),  $V_{CC} = V_{CE}$  (5V),  $A_9 = V_{PE}$  (14V),  $A_0$  low, and all other address pins low and data input pins high. Pulsing  $\overline{CE}$  low starts the erase operation.

### Erase Verify Mode

After an erase operation, all of the bytes in the chip must be verified to check whether they have been successfully erased to "1" or not. The erase verify mode ensures a substantial erase margin if  $V_{CC} = V_{CE}$  (3.75V),  $\overline{CE}$  low, and  $\overline{OE}/V_{PP}$  low.

### Program Mode

Programming is performed exactly as it is in conventional UVEPROMs, and programming is the only way to change cell data from "1" to "0." The program mode is entered when  $\overline{OE}/V_{PP}$  is raised to  $V_{PP}$  (12V),  $V_{CC} = V_{CP}$  (5V), the address pins equal the desired addresses, and the input pins equal the desired inputs. Pulsing  $\overline{CE}$  low starts the programming operation.

### Program Verify Mode

All of the bytes in the chip must be verified to check whether they have been successfully programmed with the desired data or not. Hence, after each byte is programmed, a program verify operation should be performed. The program verify mode automatically ensures a substantial program margin. This mode will be entered after the program operation if  $\overline{OE}/V_{PP}$  low and  $\overline{CE}$  low.

### Erase/Program Inhibit

Erase or program inhibit mode allows parallel erasing or programming of multiple chips with different data. When  $\overline{CE}$  high, erasing or programming of non-target chips is inhibited, so that except for the  $\overline{CE}$  and  $\overline{OE}/V_{PP}$  pins, the W27C512 may have common inputs.



### Standby Mode

The standby mode significantly reduces VCC current. This mode is entered when  $\overline{CE}$  high. In standby mode, all outputs are in a high impedance state, independent of  $\overline{OE}/V_{PP}$ .

### Two-line Output Control

Since EPROMs are often used in large memory arrays, the W27C512 provides two control inputs for multiple memory connections. Two-line control provides for lowest possible memory power dissipation and ensures that data bus contention will not occur.

### System Considerations

An EPROM's power switching characteristics require careful device decoupling. System designers are interested in three supply current issues: standby current levels ( $I_{SB}$ ), active current levels ( $I_{CC}$ ), and transient current peaks produced by the falling and rising edges of  $\overline{CE}$ . Transient current magnitudes depend on the device output's capacitive and inductive loading. Two-line control and proper decoupling capacitor selection will suppress transient voltage peaks. Each device should have a 0.1  $\mu$ F ceramic capacitor connected between its VCC and GND. This high frequency, low inherent-inductance capacitor should be placed as close as possible to the device. Additionally, for every eight devices, a 4.7  $\mu$ F electrolytic capacitor should be placed at the array's power supply connection between VCC and GND. The bulk capacitor will overcome voltage slumps caused by PC board trace inductances.



## 7. TABLE OF OPERATING MODES

(V<sub>PP</sub> = 12V, V<sub>PE</sub> = 14V, V<sub>HH</sub> = 12V, V<sub>CP</sub> = 5V, V<sub>CE</sub> = 5V, X = V<sub>IH</sub> or V<sub>IL</sub>)

MODE	PINS					
	$\overline{\text{CE}}$	$\overline{\text{OE/PP}}$	A0	A9	V <sub>CC</sub>	OUTPUTS
Read	V <sub>IL</sub>	V <sub>IL</sub>	X	X	V <sub>CC</sub>	DOUT
Output Disable	V <sub>IL</sub>	V <sub>IH</sub>	X	X	V <sub>CC</sub>	High Z
Standby (TTL)	V <sub>IH</sub>	X	X	X	V <sub>CC</sub>	High Z
Standby (CMOS)	V <sub>CC</sub> ±0.3V	X	X	X	V <sub>CC</sub>	High Z
Program	V <sub>IL</sub>	V <sub>PP</sub>	X	X	V <sub>CP</sub>	DIN
Program Verify	V <sub>IL</sub>	V <sub>IL</sub>	X	X	V <sub>CC</sub>	DOUT
Program Inhibit	V <sub>IH</sub>	V <sub>PP</sub>	X	X	V <sub>CP</sub>	High Z
Erase	V <sub>IL</sub>	V <sub>PE</sub>	V <sub>IL</sub>	V <sub>PE</sub>	V <sub>CE</sub>	DIH
Erase Verify	V <sub>IL</sub>	V <sub>IL</sub>	X	X	3.75	DOUT
Erase Inhibit	V <sub>IH</sub>	V <sub>PE</sub>	X	X	V <sub>CE</sub>	High Z
Product Identifier-manufacturer	V <sub>IL</sub>	V <sub>IL</sub>	V <sub>IL</sub>	V <sub>HH</sub>	V <sub>CC</sub>	DA (Hex)
Product Identifier-device	V <sub>IL</sub>	V <sub>IL</sub>	V <sub>IH</sub>	V <sub>HH</sub>	V <sub>CC</sub>	08 (Hex)



## 8. DC CHARACTERISTICS

### Absolute Maximum Ratings

PARAMETER	RATING	UNIT
Operation Temperature	0 to +70	°C
Storage Temperature	-65 to +125	°C
Voltage on all Pins with Respect to Ground Except $\overline{OE}/V_{PP}$ , A9 and VCC Pins	-0.5 to VCC +0.5	V
Voltage on $\overline{OE}/V_{PP}$ Pin with Respect to Ground	-0.5 to +14.5	V
Voltage on A9 Pin with Respect to Ground	-0.5 to +14.5	V
Voltage VCC Pin with Respect to Ground	-0.5 to +7	V

**Note:** Exposure to conditions beyond those listed under Absolute Maximum Ratings may adversely affect the life and reliability of the device.

### DC Erase Characteristics

( $T_A = 25^\circ\text{C} \pm 5^\circ\text{C}$ ,  $V_{CC} = 5.0\text{V} \pm 5\%$ )

PARAMETER	SYM.	CONDITIONS	LIMITS			UNIT
			MIN.	TYP.	MAX.	
Input Load Current	ILI	$V_{IN} = V_{IL}$ or $V_{IH}$	-10	-	10	$\mu\text{A}$
VCC Erase Current	ICP	$\overline{CE} = V_{IL}$ , $\overline{OE}/V_{PP} = V_{PE}$	-	-	30	mA
VPP Erase Current	IPP	$\overline{CE} = V_{IL}$ , $\overline{OE}/V_{PP} = V_{PE}$	-	-	30	mA
Input Low Voltage	VIL	-	-0.3	-	0.8	V
Input High Voltage	VIH	-	2.4	-	5.5	V
Output Low Voltage (Verify)	VOL	$I_{OL} = 2.1\text{ mA}$	-	-	0.45	V
Output High Voltage (Verify)	VOH	$I_{OH} = -0.4\text{ mA}$	2.4	-	-	-
A9 Erase Voltage	VID	-	13.75	14	14.25	V
VPP Erase Voltage	VPE	-	13.75	14	14.25	V
VCC Supply Voltage (Erase)	VCE	-	4.75	5.0	5.25	V
VCC Supply Voltage (Erase Verify)	VCE	-	3.5	3.75	4.0	V

**Note:** VCC must be applied simultaneously or before VPP and removed simultaneously or after VPP.



## 9. CAPACITANCE

( $V_{CC} = 5V$ ,  $T_A = 25^\circ C$ ,  $f = 1\text{ MHz}$ )

PARAMETER	SYMBOL	CONDITIONS	MAX.	UNIT
Input Capacitance	$C_{IN}$	$V_{IN} = 0V$	6	pF
Output Capacitance	$C_{OUT}$	$V_{OUT} = 0V$	12	pF

## 10. AC CHARACTERISTICS

### AC Test Conditions

PARAMETER	CONDITIONS	
	45/70 nS	90/120 nS
Input Pulse Levels	0 to 3.0V	0.45V to 2.4V
Input Rise and Fall Times	5 nS	10 nS
Input and Output Timing Reference Level	1.5V/1.5V	0.8V/2.0V
Output Load	$C_L = 30\text{ pF}$ , $I_{OH}/I_{OL} = -0.4\text{ mA}/2.1\text{ mA}$	$C_L = 100\text{ pF}$ , $I_{OH}/I_{OL} = -0.4\text{ mA}/2.1\text{ mA}$

### AC Test Load and Waveforms

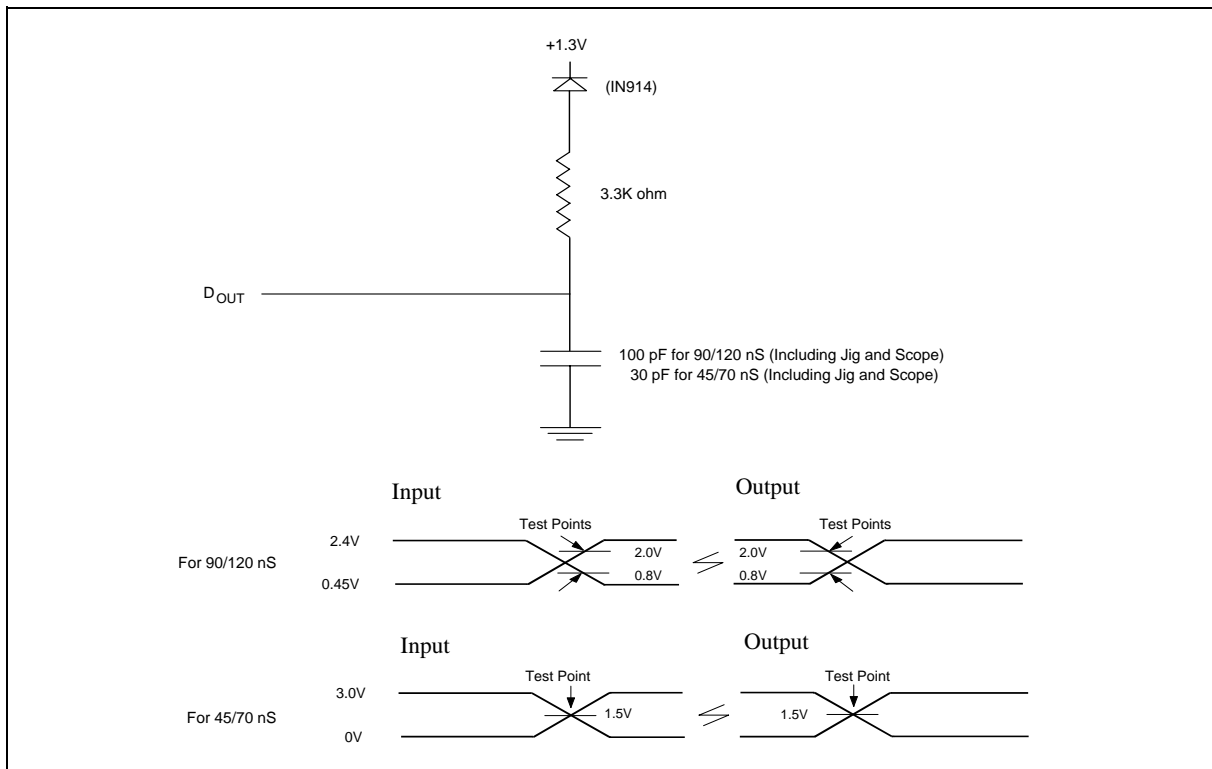



## 11. READ OPERATION DC CHARACTERISTICS

(V<sub>CC</sub> = 5.0V ±5%, T<sub>A</sub> = 0 to 70° C)

PARAMETER	SYM.	CONDITIONS	LIMITS			UNIT
			MIN.	TYP.	MAX.	
Input Load Current	I <sub>LI</sub>	V <sub>IN</sub> = 0V to V <sub>CC</sub>	-5	-	5	μA
Output Leakage Current	I <sub>LO</sub>	V <sub>OUT</sub> = 0V to V <sub>CC</sub>	-10	-	10	μA
Standby V <sub>CC</sub> Current (TTL input)	I <sub>SB</sub>	$\overline{CE} = V_{IH}$	-	-	1.0	mA
Standby V <sub>CC</sub> Current (CMOS input)	I <sub>SB1</sub>	$\overline{CE} = V_{CC} \pm 0.3V$	-	5	100	μA
V <sub>CC</sub> Operating Current	I <sub>CC</sub>	$\overline{CE} = V_{IL}$ I <sub>OUT</sub> = 0 mA, f = 5 MHz	-	-	30	mA
Input Low Voltage	V <sub>IL</sub>	-	-0.3	-	0.8	V
Input High Voltage	V <sub>IH</sub>	-	2.2	-	V <sub>CC</sub> + 0.5	V
Output Low Voltage	V <sub>OL</sub>	I <sub>OL</sub> = 2.1 mA	-	-	0.45	V
Output High Voltage	V <sub>OH</sub>	I <sub>OH</sub> = -0.4 mA	2.4	-	-	V

## 12. READ OPERATION AC CHARACTERISTICS

(V<sub>CC</sub> = 5.0V ±5%, T<sub>A</sub> = 0 to 70° C)

PARAMETER	SYM.	W27C512-45		W27C512-70		W27C512-90		W27C512-12		UNIT
		MIN.	MAX.	MIN.	MAX.	MIN.	MAX.	MIN.	MAX.	
Read Cycle Time	T <sub>RC</sub>	45	-	70	-	90	-	120	-	nS
Chip Enable Access Time	T <sub>CE</sub>	-	45	-	70	-	90	-	120	nS
Address Access Time	T <sub>ACC</sub>	-	45	-	70	-	90	-	120	nS
Output Enable Access Time	T <sub>OE</sub>	-	20	-	30	-	40	-	55	nS
$\overline{OE}$ /V <sub>PP</sub> High to High-Z Output	T <sub>DF</sub>	-	20	-	30	-	30	-	30	nS
Output Hold from Address Change	T <sub>OH</sub>	0	-	0	-	0	-	0	-	nS

**Note:** V<sub>CC</sub> must be applied simultaneously or before V<sub>PP</sub> and removed simultaneously or after V<sub>PP</sub>.



### 13. DC PROGRAMMING CHARACTERISTICS

(VCC = 5.0V ±5%, TA = 25° C ±5° C)

PARAMETER	SYM.	CONDITIONS	LIMITS			UNIT
			MIN.	TYP.	MAX.	
Input Load Current	ILI	VIN = VIL or VIH	-10	-	10	μA
VCC Program Current	ICP	$\overline{CE} = V_{IL}$ , $\overline{OE} / V_{PP} = V_{PP}$	-	-	30	mA
VPP Program Current	IPP	$\overline{CE} = V_{IL}$ , $\overline{OE} / V_{PP} = V_{PP}$	-	-	30	mA
Input Low Voltage	VIL	-	-0.3	-	0.8	V
Input High Voltage	VIH	-	2.4	-	5.5	V
Output Low Voltage (Verify)	VOL	IOL = 2.1 mA	-	-	0.45	V
Output High Voltage (Verify)	VOH	IOH = -0.4 mA	2.4	-	-	V
A9 Silicon I.D. Voltage	VID	-	11.5	12.0	12.5	V
VPP Program Voltage	VPP	-	11.75	12.0	12.25	V
VCC Supply Voltage (Program)	VCP	-	4.75	5.0	5.25	V



#### 14. AC PROGRAMMING/ERASE CHARACTERISTICS

(VCC = 5.0V ±5%, TA = 25° C ±5° C)

PARAMETER	SYM.	LIMITS			UNIT
		MIN.	TYP.	MAX.	
$\overline{OE}$ /VPP Pulse Rise Time	TPRT	50	-	-	nS
Data Setup Time	TDS	2.0	-	-	μS
$\overline{CE}$ Program Pulse Width	TPWP	95	100	105	μS
$\overline{CE}$ Erase Pulse Width	TPWE	95	100	105	mS
Data Hold Time	TDH	2.0	-	-	μS
$\overline{OE}$ /VPP Setup Time	TOES	2.0	-	-	μS
$\overline{OE}$ /VPP Hold Time	TOEH	2.0	-	-	μS
Data Valid from $\overline{CE}$	TDV1	25	-	1	μS
Data Valid from Address Change	TDV2	25	-	1	μS
$\overline{CE}$ High to Output High Z	TDFP	0	-	130	nS
Address Setup Time	TAS	2.0	-	-	μS
Address Hold Time	TAH	0	-	-	μS
Address Hold Time after $\overline{CE}$ High (Erase)	TAHC	2.0	-	-	μS
$\overline{OE}$ /VPP Valid after $\overline{CE}$ High	TVS	2.0	-	-	μS
$\overline{OE}$ /VPP Recovery Time	TVR	2.0	-	-	μS
Address Access Time During Erase Verify (VCC = 3.75V)	TACV	-	-	250	nS
Output Enable Access Time during Erase Verify (VCC = 3.75V)	TOEV	-	-	150	nS

**Note:** Vcc must be applied simultaneously or before Vpp and removed simultaneously or after Vpp.





Timing Waveforms, continued

Programming Waveform

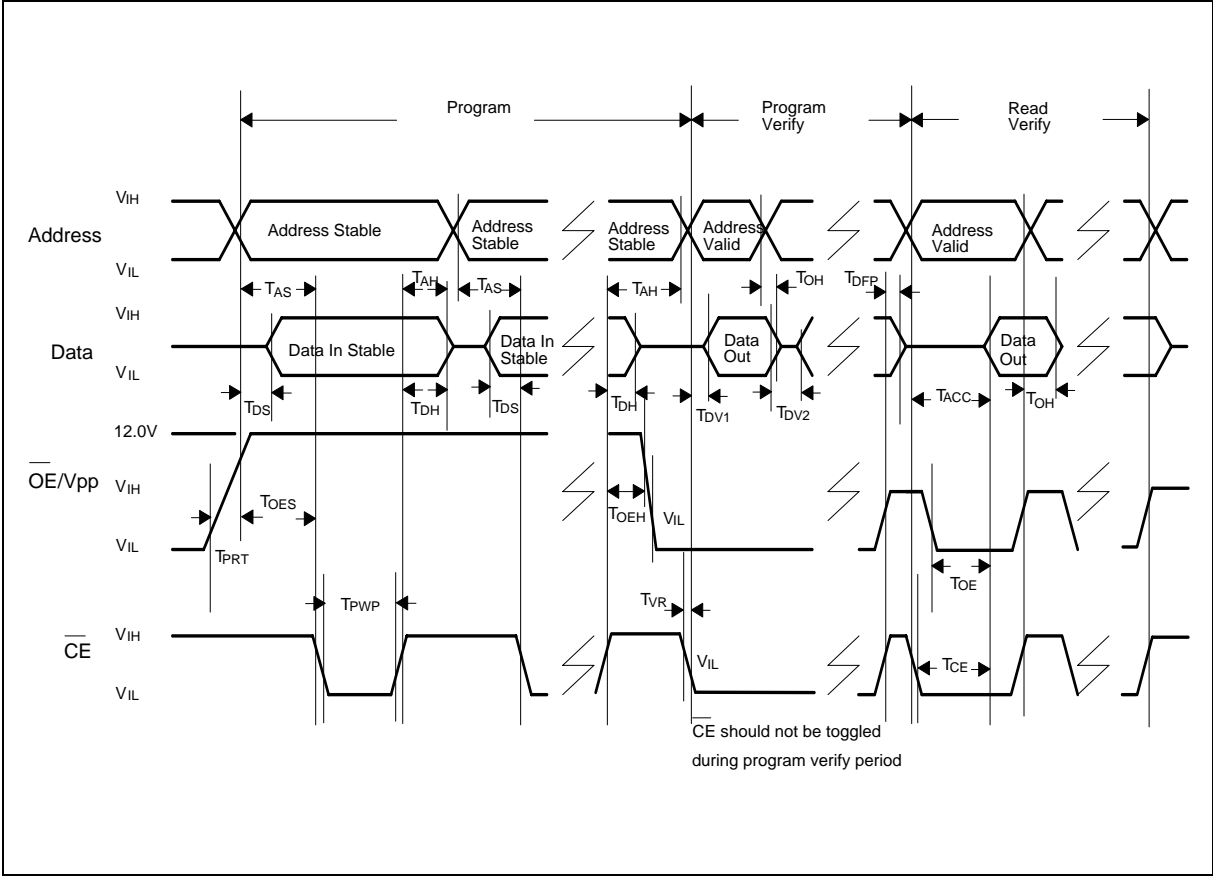



16. SMART PROGRAMMING ALGORITHM 1

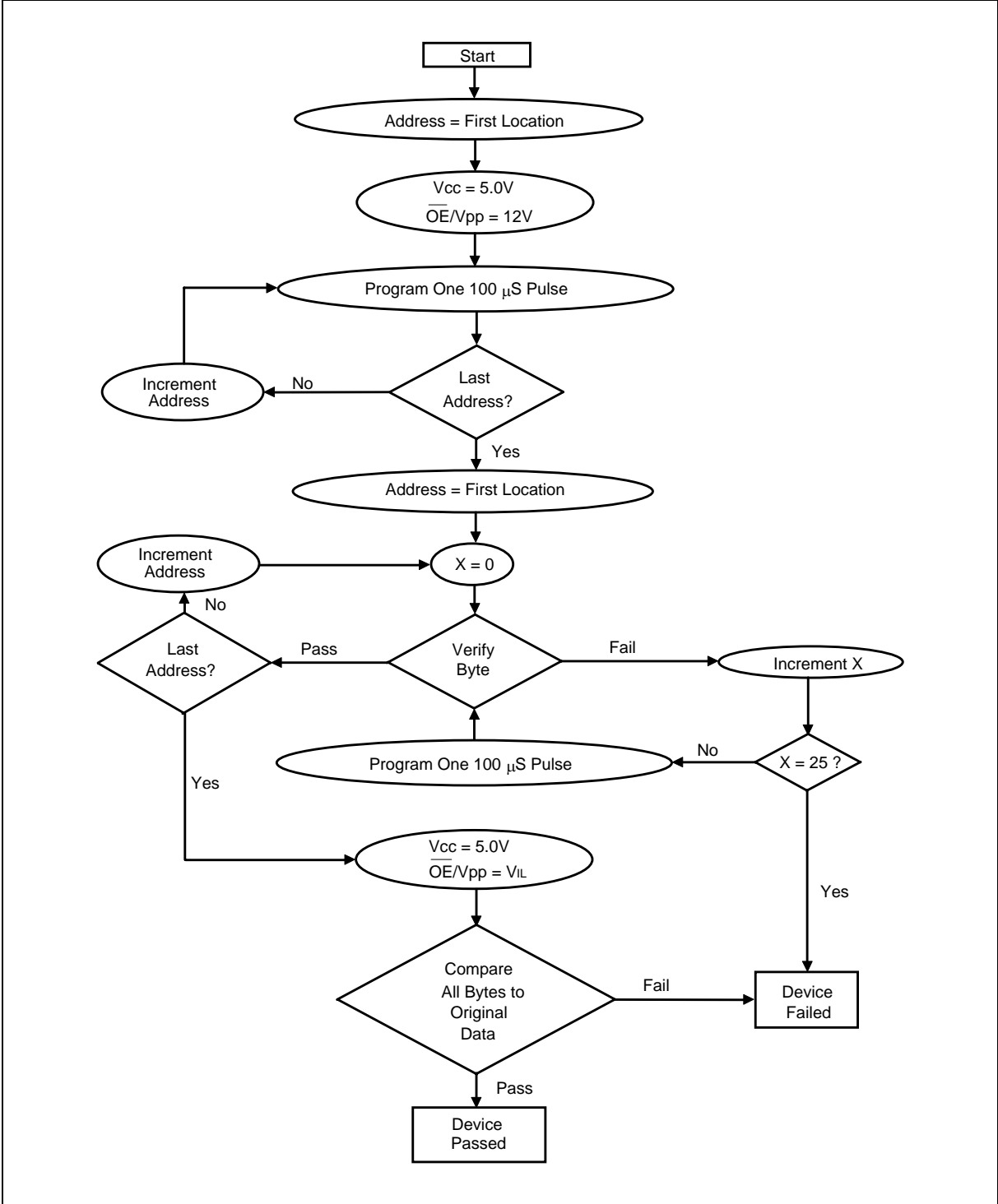



17. SMART PROGRAMMING ALGORITHM 2

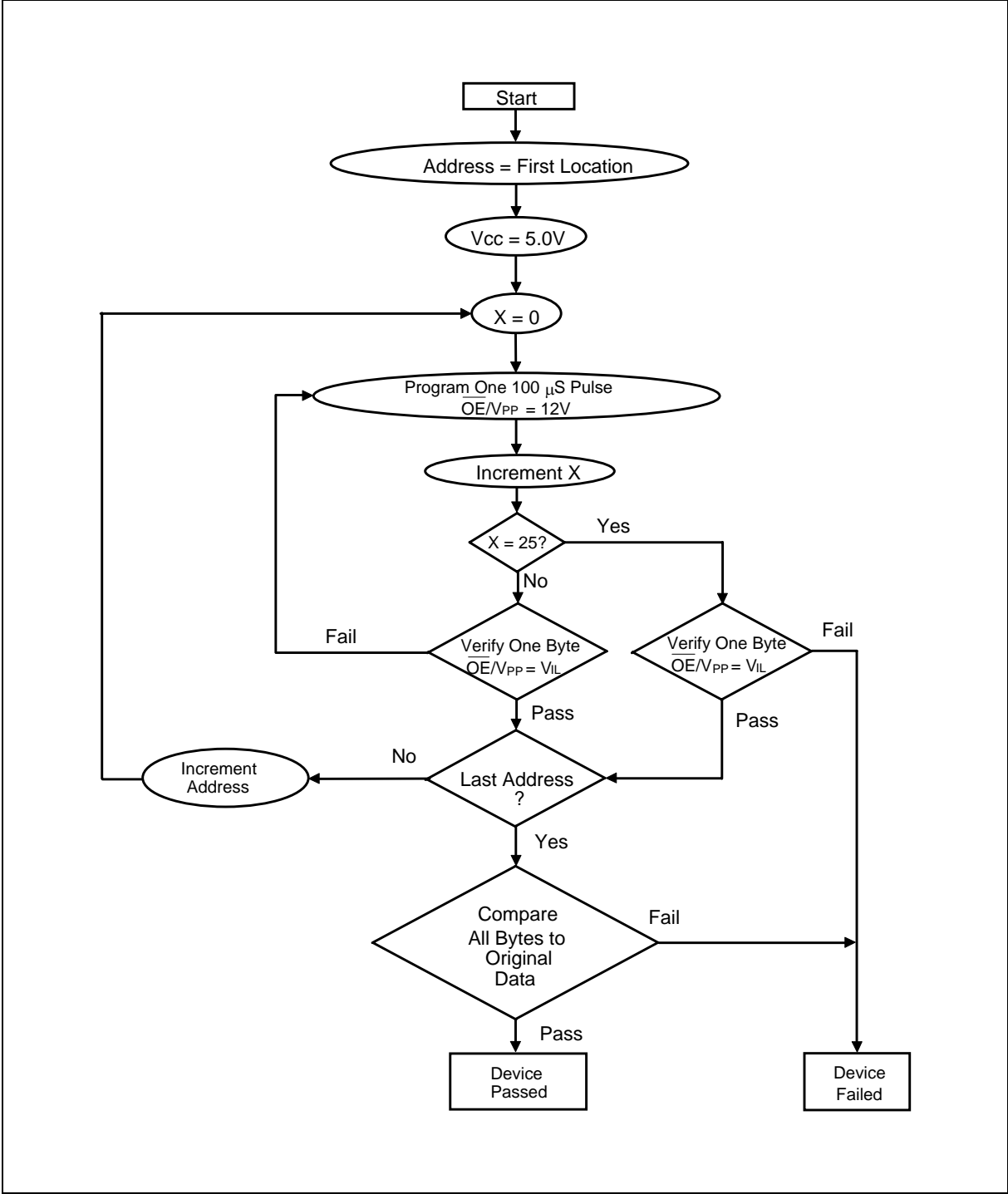



18. SMART ERASE ALGORITHM

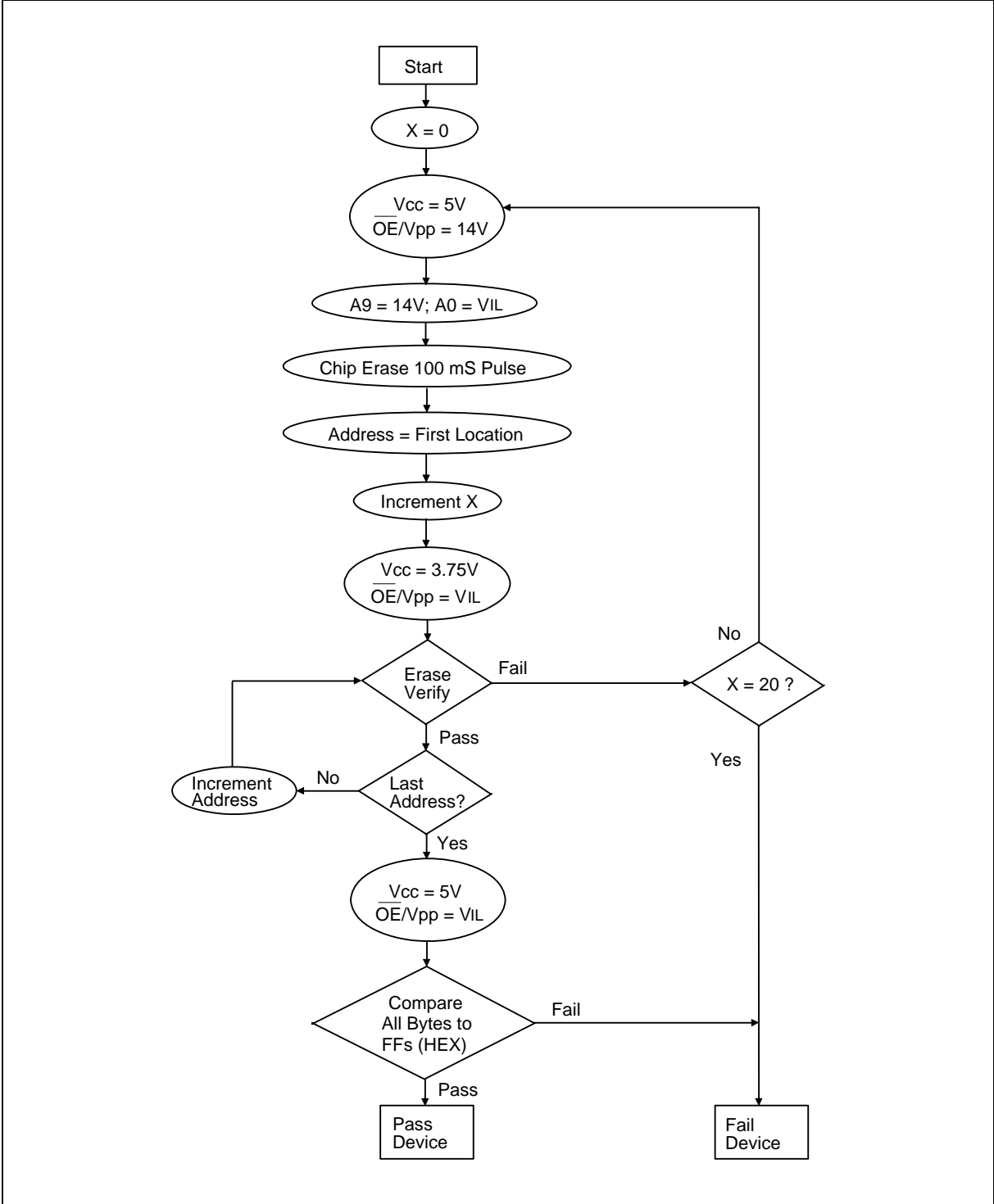



## 19. ORDERING INFORMATION

PART NO.	ACCESS TIME (nS)	OPERATING CURRENT MAX. (mA)	STANDBY CURRENT MAX. (μA)	PACKAGE
W27C512-45	45	30	100	600 mil DIP
W27C512-70	70	30	100	600 mil DIP
W27C512-90	90	30	100	600 mil DIP
W27C512-12	120	30	100	600 mil DIP
W27C512P-45	45	30	100	32-pin PLCC
W27C512P-70	70	30	100	32-pin PLCC
W27C512P-90	90	30	100	32-pin PLCC
W27C512P-12	120	30	100	32-pin PLCC
W27C512-45Z	45	30	100	600 mil DIP Lead Free
W27C512P-45Z	45	30	100	32-pin PLCC Lead Free

### Notes:

1. Winbond reserves the right to make changes to its products without prior notice.
2. Purchasers are responsible for performing appropriate quality assurance testing on products intended for use in applications where personal injury might occur as a consequence of product failure.



20. PACKAGE DIMENSIONS

28-pin P-DIP

Symbol	Dimension in Inches			Dimension in mm		
	Min.	Nom.	Max.	Min.	Nom.	Max.
A	—	—	0.210	—	—	5.33
A <sub>1</sub>	0.010	—	—	0.25	—	—
A <sub>2</sub>	0.150	0.155	0.160	3.81	3.94	4.06
B	0.016	0.018	0.022	0.41	0.46	0.56
B <sub>1</sub>	0.058	0.060	0.064	1.47	1.52	1.63
C	0.008	0.010	0.014	0.20	0.25	0.36
D	—	1.460	1.470	—	37.08	37.34
E	0.590	0.600	0.610	14.99	15.24	15.49
E <sub>1</sub>	0.540	0.545	0.550	13.72	13.84	13.97
e <sub>1</sub>	0.090	0.100	0.110	2.29	2.54	2.79
L	0.120	0.130	0.140	3.05	3.30	3.56
a	0	—	15	0	—	15
e <sub>A</sub>	0.630	0.650	0.670	16.00	16.51	17.02
S	—	—	0.090	—	—	2.29

Notes:

1. Dimensions D Max. & S include mold flash or tie bar burrs.
2. Dimension E1 does not include interlead flash.
3. Dimensions D & E1 include mold mismatch and are determined at the mold parting line.
4. Dimension B1 does not include dambar protrusion/intrusion.
5. Controlling dimension: Inches.
6. General appearance spec. should be based on final visual inspection spec.

32-pin PLCC

Symbol	Dimension in Inches			Dimension in mm		
	Min.	Nom.	Max.	Min.	Nom.	Max.
A	—	—	0.140	—	—	3.56
A <sub>1</sub>	0.020	—	—	0.50	—	—
A <sub>2</sub>	0.105	0.110	0.115	2.67	2.80	2.93
b <sub>1</sub>	0.026	0.028	0.032	0.66	0.71	0.81
b	0.016	0.018	0.022	0.41	0.46	0.56
C	0.008	0.010	0.014	0.20	0.25	0.35
D	0.547	0.550	0.553	13.89	13.97	14.05
E	0.447	0.450	0.453	11.35	11.43	11.51
E <sub>1</sub>	0.044	0.050	0.056	1.12	1.27	1.42
G <sub>D</sub>	0.490	0.510	0.530	12.45	12.95	13.46
G <sub>E</sub>	0.390	0.410	0.430	9.91	10.41	10.92
H <sub>D</sub>	0.585	0.590	0.595	14.86	14.99	15.11
H <sub>E</sub>	0.485	0.490	0.495	12.32	12.45	12.57
L	0.075	0.090	0.095	1.91	2.29	2.41
y	—	—	0.004	—	—	0.10
θ	0	—	10	0	—	10

Notes:

1. Dimension D & E do not include interlead flash.
2. Dimension b does not include dambar protrusion/intrusion.
3. Controlling dimension: Inches.
4. General appearance spec. should be based on final visual inspection spec.



## 21. VERSION HISTORY

VERSION	DATE	PAGE	DESCRIPTION
A1	Mar. 1998		Initial Issued
A2	Sep. 1998	6	Correct Input High Voltage ( $V_{IH}$ ) from 2.0 (min) to 2.2 (max)
		4, 6	Correct VCC from 5.0 $\pm$ 10% to 5.0 $\pm$ 5%
A3	Aug. 1999	1, 5, 6, 13	Add 45 nS binning
		2, 3	Modify function description ( $V_{IL}$ and $V_{IH}$ ): $V_{IL} \rightarrow$ Low; $V_{IH} \rightarrow$ High
A4	Nov. 1999	6	Typo correction
A5	April 14, 2005	15	Adding important notice
A6	Jan. 9, 2006	18	Ordering Information: Add W27C512-45Z and W27C512P-45Z Lead free part

### Important Notice

Winbond products are not designed, intended, authorized or warranted for use as components in systems or equipment intended for surgical implantation, atomic energy control instruments, airplane or spaceship instruments, transportation instruments, traffic signal instruments, combustion control instruments, or for other applications intended to support or sustain life. Further more, Winbond products are not intended for applications wherein failure of Winbond products could result or lead to a situation wherein personal injury, death or severe property or environmental damage could occur.

Winbond customers using or selling these products for use in such applications do so at their own risk and agree to fully indemnify Winbond for any damages resulting from such improper use or sales.