



Winbond ACPI-STR Controller W83301DR-O

Date: 2002/07 Revision: 1.0

1. General Description

The W83301DR-O is an ACPI-compliant controller for microprocessor and other computer applications. The part provides functions - two switch controllers to generate a $5V_{DL}$ and a $3.3V_{DL}$ voltage from ATX power supply; a linear controller – STR1 ($2.5V_{DUAL}$), and a bus termination controller – STR2 ($1.25V_{DUAL}$) for high-speed bus such as RDRAM/DDRAM current sinking and sourcing. Besides, the W83301DR-O also can provide extra voltage up to 0.4V in each regulator output for over-clocking application and more performance by two hardware pins - V_{SET2} , and V_{SET3} . In order to reduce the customer's cost, and simplify the circuit design, the W83301DR-O integrates a charge-pump engine into the chip to provide higher driving voltage to drive single N-channel MOSFETs. The W83301DR-O also offers PWOK and over current detection to protect each output and soft-start protects all linear controllers from rush current attack. The W83301DR-O is available in a 24-pin TSSOP package.

2. Features

- ❖ Provides various voltages for DDR-STR applications
 - Provide a switch controller to generate $5V_{DUAL}$ voltage
 - Provide a switch controller to generate $3.3V_{DUAL}$ voltage
 - Linear controller STR1– $2.5V_{DUAL}$ for DDR application
 - Bus termination controller STR2 – $1.25V_{DUAL}$ for high speed bus termination to sink and drive redundant current
- ❖ Provide a switch $5V_{DLEN}$ pin to enable/disable $5V_{DL}$ output in S5 state for USB application
- ❖ Supports DDR ACPI-STR Functions
- ❖ Drives all N-Channel MOSFETs
- ❖ Power-Up Softstart for all controllers
- ❖ Up to 0.4V/0.2V incremental voltage on STR1/STR2 for over-clocking application.
- ❖ Under-Voltage Fault Monitor
- ❖ Soft-Start function
- ❖ 24-Pin TSSOP Package

3. W83301DR-O Pin Configuration

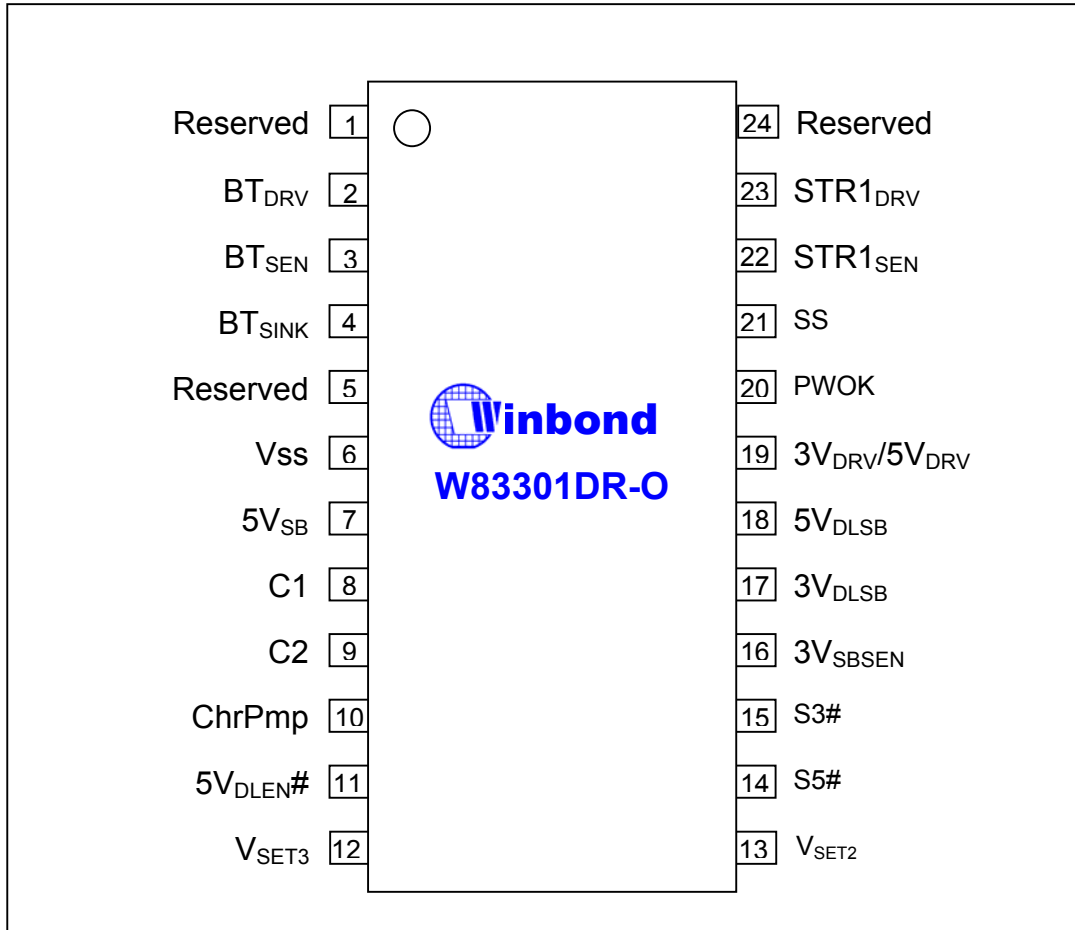

4. Pin Description

SYMBOL	PIN	FUNCTION
Reserved	1	Pin Reserved
BT _{DRV}	2	BT Current Source. Connect this pin to the gate of a suitable N-channel MOSFET for driving bus termination regulator output.
BT _{SEN}	3	BT Sense. Connect this pin to the bus termination regulator output.
BT _{SINK}	4	BT Current Sink. This pin is used to drive a N-channel MOSFET to sink the redundant current in the high-speed bus.
Reserved	5	Function Reserved. Pull up this pin to +5V _{SB} through a 1.5 Kohm resistor.
V _{SS}	6	Power Ground. Connect this pin to ground.
5V _{SB}	7	Power 5V_{SB}. Input 5V _{SB} supply.
C1	8	Charge Pump Cap. Attach flying capacitor between this pin and C2 to generate internally used high voltage from 5V power supply.
C2	9	Charge Pump Cap. Attach flying capacitor between this pin and C1 to generate internally used high voltage from 5V power supply.
ChrPmp	10	Charge Pump output. This pin produces voltage doubled 5V supply by charge pumping. Bypass with a 0.1uF capacitor.
5V _{DLEN#}	11	5VDL Enable. Control 5V _{DL} voltage output. Pull-up internally.
V _{SET3}	12	Voltage Selection. Combine with VSET2 to select output voltages of STR regulators.
V _{SET2}	13	Voltage Selection. Combine with VSET3 to select output voltages of STR regulators.
S5#	14	S5 Signal. Control signal governing the soft off state S5. Pull-up internally.
S3#	15	S3 Signal. Control signal governing the soft off state S3. Pull-up internally.
3V _{SBSSEN}	16	3V_{DL} Sense. Connect this pin to the STR1 output.
3V _{DLSB}	17	3V_{DL} Drive. Connect this pin to the gate of a suitable N-channel MOSFET for driving STR1 output.
5V _{DLSB}	18	5V_{SB} Output Control. Connect this pin to the gate of a N-MOSFET to output 5V _{SB} power to 5V _{DL} .
3V _{DRV} /5V _{DRV}	19	3.3V/5V Output Control. Connect this pin to the gate of a N-MOSFET to output 3.3V/5V power to 3.3V _{DL} /5V _{DL} .
PWOK	20	Power OK. Open collector input/output. Used to indicate the ready of 5Vin supply. If any STR supply occurs over current and induce under-voltage, PWOK will be pull down.
SS	21	Soft-Start. Attach a capacitor (0.033u) to this pin to determine the softstart rate. A ramp generated by charging this capacitor with internal soft-start current (18uA) is used to clamp the voltage rising slew rate of STR regulators and 5V _{DL} . Soft starting avoids too much rush current during voltage setup.
STR1 _{SEN}	22	STR1 Sense. Connect this pin to the STR1 output.
STR1 _{DRV}	23	STR1 Drive. Connect this pin to the gate of a suitable N-channel MOSFET for driving STR1 output.
Reserved	24	Pin Reserved

5. W83301DR-O Dual-Layout with W83301R/W83301DR

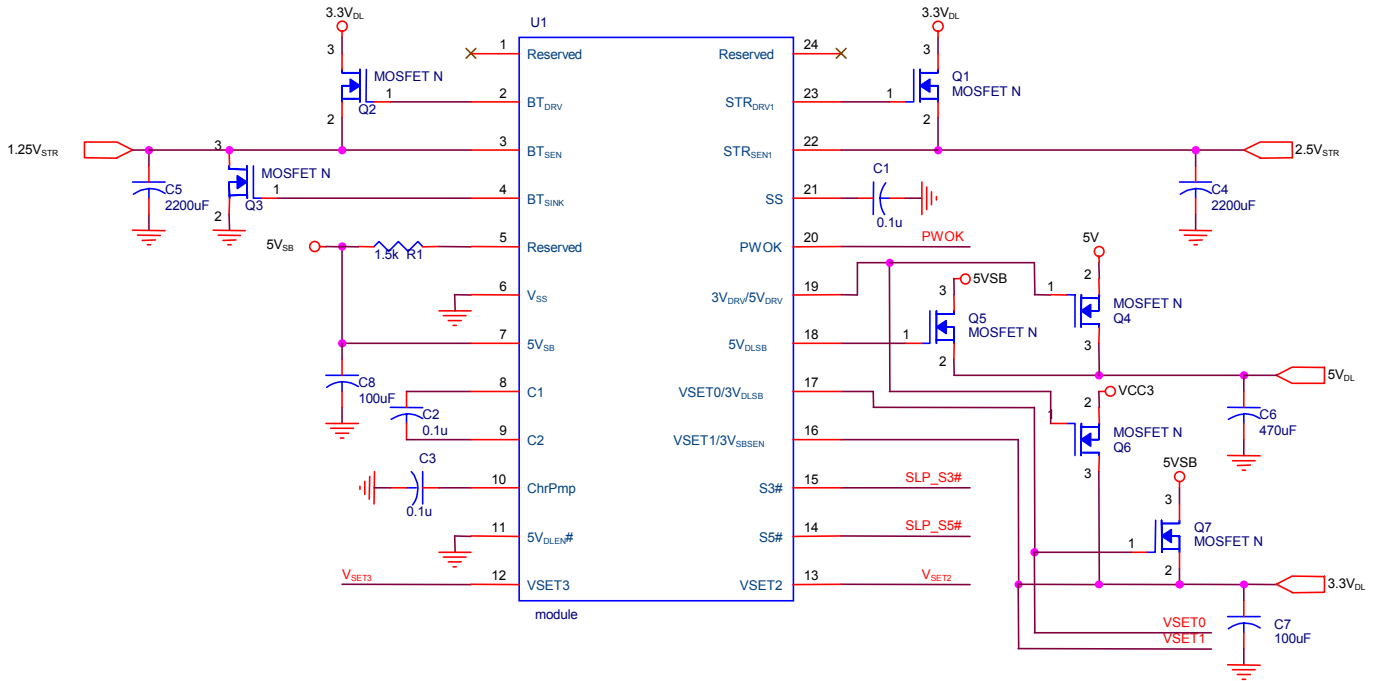

Mode	VSET0	VSET1	STR1	Bus Termination Controller
DDR 20-pin	0V	0V	2.5VSTR	1.25VSTR
	0V	NC	2.6VSTR	1.30VSTR
	0V	5V	2.7VSTR	1.35VSTR

Mode	VSET2	VSET3	STR1	Bus Termination Controller
DDR 24-pin	0V	0V	2.5VSTR	1.25VSTR
	5V	0V	2.63VSTR	1.325VSTR
	0V	5V	2.77VSTR	1.385VSTR
	5V	5V	2.9VSTR	1.45VSTR

6. Internal Block Diagram

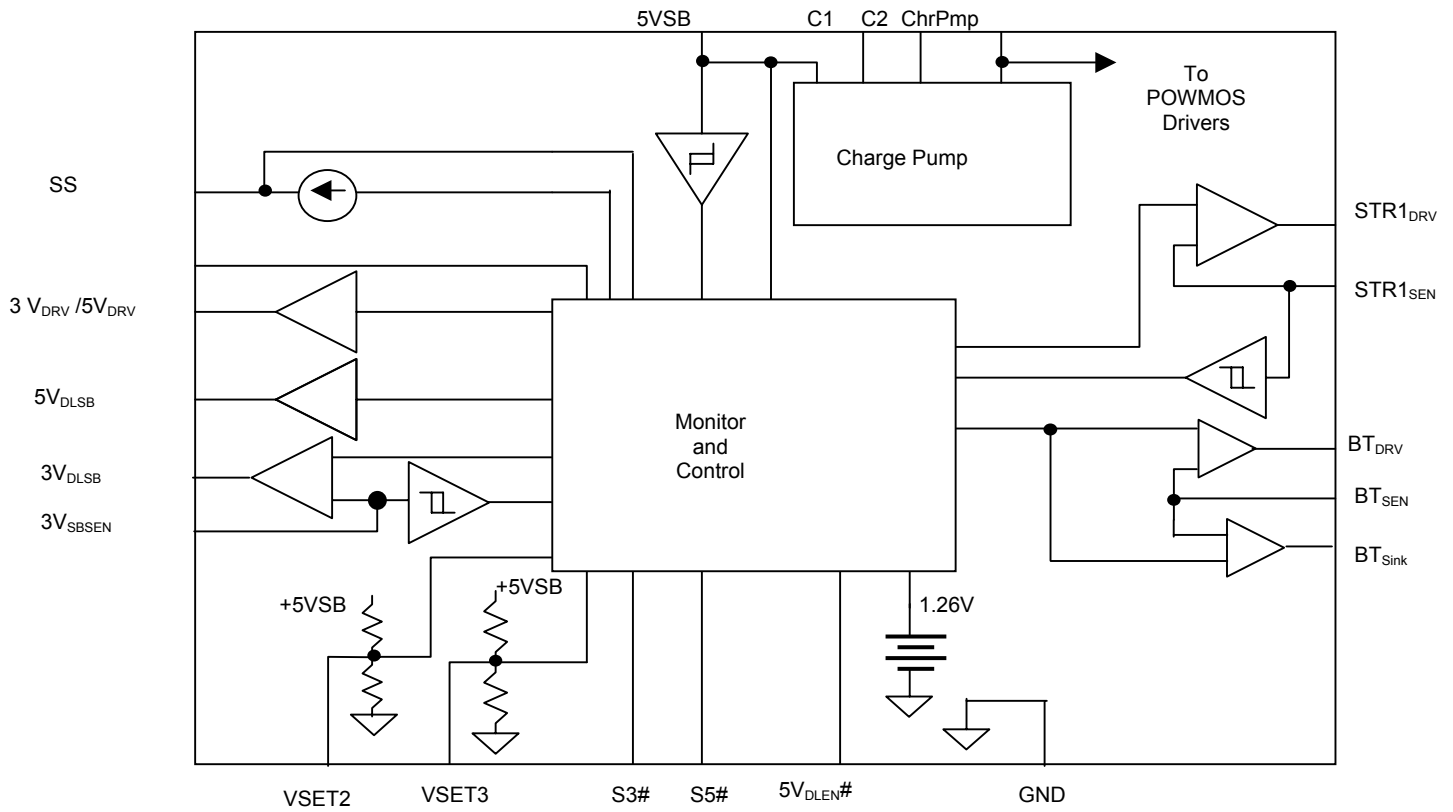

7. Functional Description

7.1 ACPI State Control

In order to meet the ACPI specification, the W83301DR-O implements an internal state machine to generate ACPI-compliant power state transition.

There are five states in the state machine, the five states are G3 (Mechanical-Off State), S0 (Full-Power State), S3 (Sleeping State-Suspend to RAM), S5_{On} (Soft-Off State), S5_{Off} and all of the state changes to the other according to the value of S3#, S5# and 5V_{DLEN#}. On the other hand, cause of the W83301DR-O allows the user to disable/enable the 5V_{DUAL} output in S5 state via the 5V_{DLEN#} pin, there are two states - S5_{On} and S5_{Off}, corresponding to S5 state. Besides, a soft ramp-up mechanism is needed to protect the 5V_{DL} output from the rush current attack during the S5_{Off} to S5_{On} state transition. Same as the 5V_{DL} output, the W83301DR-O also implements soft ramp-up mechanism in each STR outputs during the S5_{On} state transfers to the S0 state.

As the internal state machine, when the power turns on, the voltage of 5V_{SB} of the ATX power supply ramps up to 4.5V, the chip will enter the S5_{Off} state from the G3 state, and will enter the S5_{On} state if the signal of 5V_{DLEN#}=0 and S5#=0; When the signals S3#=1 and S5#=1, the system will enter the S0 state from S5_{Off}.

In the S5_{On} state, the chip will return back to the S5_{Off} state if the 5V_{DLEN#}=1 is set.

When the system in the S0 state, the system will enter the S3 (S3#=0, S5#=1) or S5 (S5#=0) state when the system is idle for a long time or user presses the power button.

When the system enters the S3 state, the system will wake up and enter the S0 state by (S3#=1, S5#=1, PWOK=1), or gets into S5 state by (S5#=0).

Table 1. W83301DR-O Outputs Table

State	5V _{DL}	3V _{DL}	STR1	STR2	LUV Activity *
G3	Off	Off	Off	Off	No
S5 (5V _{DL} Off)	Off	On (Driven by 3V _{DLSB})	Off	Off	No
S5 (5V _{DL} On)	On (Driven by 5V _{DLSB})	On (Driven by 3V _{DLSB})	Off	Off	No
S0	On (Driven by 5V _{DRV})	On (Driven by 3V _{DRV})	On	On	Yes
S3	On (Driven by 5V _{DLSB})	On (Driven by 3V _{DLSB})	On	On	Yes

* Only the STR1 has linear under voltage function.

7.3 Charge Pump

In order to simplify the design circuit and provide a cost-effective solution for customer, the W83301DR-O integrates with a switched-capacitor voltage doublers charge pump to provide a higher driving voltage (Up to 10 volt) and can drive single N-channel MOSFETs in each output.

7.4 Power OK

The W83301DR-O use a bi-direction Power OK signal to ensure the system can work normally. When the system jump from the state S3 to the state S0, the W83301DR-O will monitor the input signal from PWOK pin to ensure that external system power is OK and then will switches each outputs into the S0 state; In the other hand, the W83301DR-O will pulls down the Power OK signal to inform the system a over current and induce under-voltage occurred.

7.5 Soft-Start

During the 'S5off' to the 'S5on' and the 'S5on' to the 'S0' state transitions, the 5Vdual/3Vdual and STR voltages need to ramp up from 0V to the setting values respectively. The charging current flowing to output capacitors must be limited to avoid supply drop-off.

In W83301DR-O, an internal 18 uA current source (Iss) charges an external capacitor (Css) to generate a linear ramp-up voltage on SS pin (Vss). The Vss slews from 0V to about 9V during the above-mentioned state transitions, and the Vss slew rate is used to clamp the ramp-up rate of 5Vdual and STR output voltages. This output clamping allows power-ups free of supply drop-off events.

Since the outputs are ramped up in a constant slew-rate, the current dedicated to charge any output capacitor can be calculated with the following formula:

$$I_{COUT} = I_{ss} \times (C_{out} / C_{ss})$$

Some technique are included in W83301DR-O to further reduce the total charging current: the bus-terminator is input clamped, and its output voltage slew-rate, so as its charging current, will be limited to half of that of STR1.

Note that, too slow ramp-up rate is not recommended. If so, the state transition mentioned above will be prolonged to much. Before Vss ramps up to its upper limit (about 9V), the state transition will not be completed and will not go into next state.

8. Electrical Characteristics

8.1 ABSOLUTE MAXIMUM RATINGS

Stresses greater than those listed in this table may cause permanent damage to the device. Precautions should be taken to avoid application of any voltage higher than the maximum rated voltages to this circuit. Subjection to maximum conditions for extended periods may affect reliability. Unused inputs must always be tied to an appropriate logic voltage level (Ground or Vdd).

Symbol	Parameter	Rating
V _{SS} , V _{CC}	Voltage on any pin with respect to GND	- 0.5 V to + 7.0 V
ChrPmp		- 0.5 V to + 12.0 V
Hi-V Pins	Pin# 2,3,4,5,9,10,17,18,19,21,22,23	GND-0.3 V to V _{Chr-Pmp} + 0.3V
Lo-V Pins	Pin# 8,11,12,13,14,15,16,20	GND-0.3 V to V _{CC} + 0.3V
T _{STG}	Storage Temperature	- 65°C to + 150°C
T _B	Ambient Temperature	- 55°C to + 125°C
T _A	Operating Temperature	0°C to + 70°C

8.2 AC CHARACTERISTICS

V_{CC}=5V ± 5 %, T_A = 0°C to +70°C						
Parameter	Symbol	Min	Typ	Max	Units	Test Conditions
V_{CC} SUPPLY CURRENT						
Norminal Supply Current	I _{5VSB}		6		mA	
POWER-ON RESET						
Rising V _{5VSB} Threshold				4.3	V	V _{Chr_Pmp} > 8.5V
5VSB Hysteresis			1		V	
Rising V _{Chr_Pmp} Threshold				8.5	V	V _{5VSB} > 4.3V
V _{Chr_Pmp} Hysteresis			1		V	
SOFT-START						
Soft-Start Current	I _{SS}		18		uA	
V _{SS} upper limit			9		V	

8.2 AC CHARACTERISTICS (Continued)

V_{CC}=5V ± 5 %, T_A = 0 °C to +70 °C						
Parameter	Symbol	Min	Typ	Max	Units	Test Conditions
STR1 LINEAR REGULATOR						
Nominal Output Voltage			2.5		V	Vset2=0V; Vset3=0V
Nominal Output Voltage			2.63		V	Vset2=5V; Vset3=0V
Nominal Output Voltage			2.77		V	Vset2=0V; Vset3=5V
Nominal Output Voltage			2.90		V	Vset2=5V; Vset3=5V
Regulation		3		3	%	
STR _{SEN1} Under-Voltage Falling Threshold			80		%	
MAX STR _{DRV1} Output Voltage		6			V	I (STR _{DRV1}) < 0.1mA
BUS TERMINATION REGULATOR						
Nominal Output Voltage / V _{STRSEN1}			50		%	The output is always the 50% of STR1
Regulation		-2		3	%	
5VDUAL SWITCH CONTROLLER						
5V _{DRV} Output High Voltage		9				Cload=3000p
5V _{DRV} Sourcing Current			7		mA	Cload=3000p
5V _{DRV} Sinking Current			400		uA	Cload=3000p
5V _{DLSB} Output High Voltage		9				Cload=3000p
5V _{DLSB} Sourcing Current			7		mA	Cload=3000p
5V _{DLSB} Sinking Current			230		uA	Cload=3000p
3V_{CC} SWITCH CONTROLLER						
3V _{DRV} Output High Voltage		9				Cload=3000p
3V _{DRV} Sourcing Current			7		mA	Cload=3000p
3V _{DRV} Sinking Current			400		uA	Cload=3000p
3.3V_{SB} LINEAR REGULATOR						
Nominal Output Voltage			3.3		V	
Regulation		3		3	%	
STR _{SEN1} Under-Voltage Falling Threshold			80		%	
MAX 3.3V _{DLSB} Output Voltage		6			V	I (3.3V _{DLSB}) < 0.1mA
S3#,S5#,5VDLEN#, PWOK,CHARGE PUMP						
Input Logic High	2.2				V	
Input Logic Low				0.8	V	
PWOK Output Impedence		150			ohm	LUV active
Charge Pump Frequency			200		KHz	

9. Package Dimension 24-TSSOP 173mil

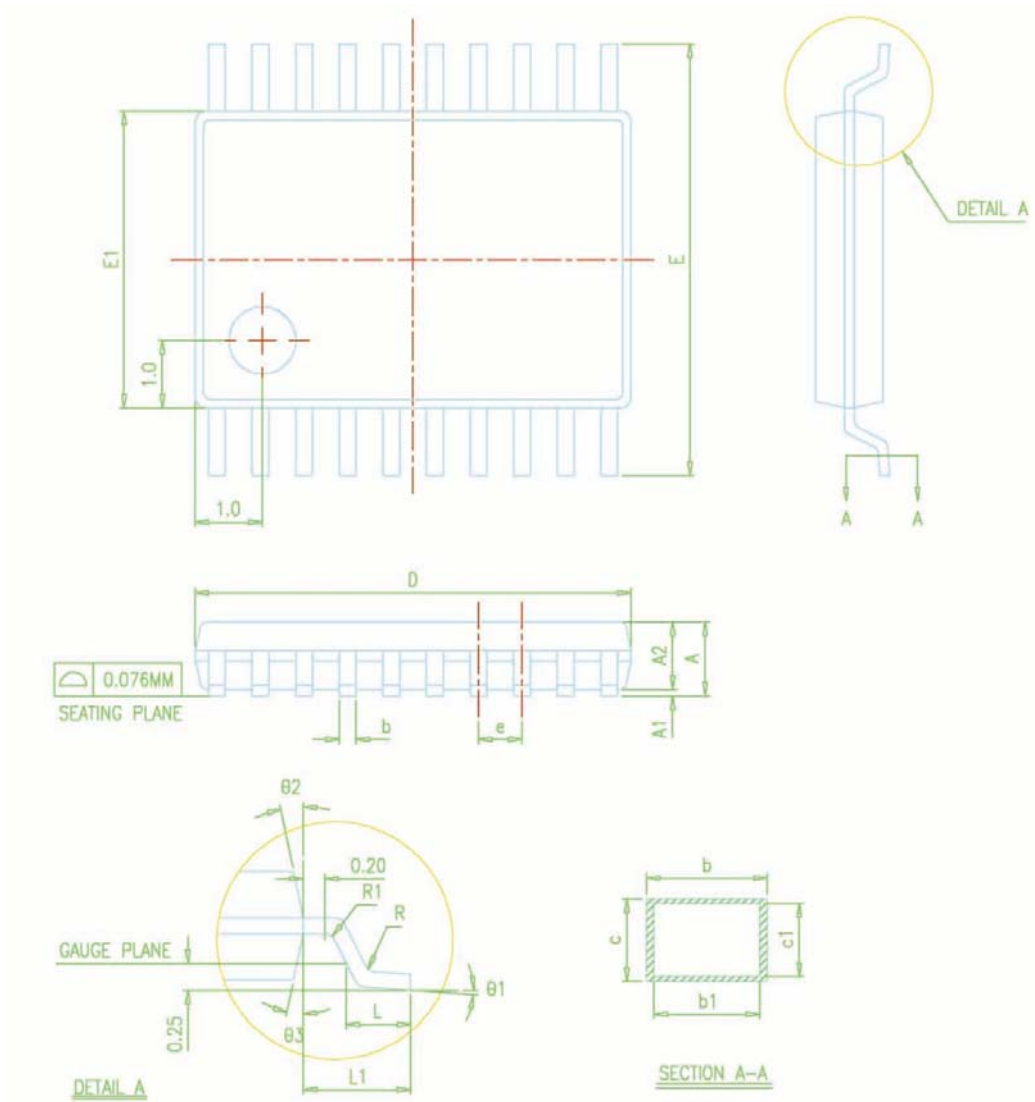

SYMBOL	DIMENSION IN MM			DIMENSION IN INCH		
	MIN.	NOM	MAX.	MIN.	NOM	MAX.
A			1.20			0.043
A1	0.05		0.15	0.002		0.006
A2	0.80	0.90	1.05	0.031	0.035	0.041
L	0.50	0.60	0.75	0.020	0.024	0.030
E'	6.40 BSC.			0.252 BSC.		
E1	4.30	4.40	4.50	0.169	0.173	0.177
R	0.09			0.004		
R1	0.09			0.004		
b	0.19		0.30	0.007		0.012
b1	0.19	0.22	0.25	0.007	0.009	0.010
c	0.09		0.20	0.004		0.008
c1	0.09		0.16	0.004		0.006
L1	1.0 REF.			0.039 REF.		
e	0.65 BSC.			0.026 BSC.		
$\theta 1$	0		8	0		8
$\theta 2$	12 REF.			12 REF.		
$\theta 3$	12 REF.			12 REF.		

N.	D (MM)			JEDEC
	MIN.	NOM	MAX.	
14	4.90	5.00	5.10	MO-153 (AB-1)
16	4.90	5.00	5.10	MO-153 (AB)
20	6.40	6.50	6.60	MO-153 (AC)
24	7.70	7.80	7.90	MO-153 (AD)
28	9.60	9.70	9.80	MO-153 (AE)

10. Ordering Information

Part Number	Package Type	Production Flow
W83301DR-O	24-PIN TSSOP	Commercial, 0°C to +70°C

11. How to Read the Top Marking



- 1st line: Winbond logo
- 2nd line: W83301DR-O – the part number
- 3rd line: Tracking code Tracking code 106 O B 1 1039050-21NA
- 106**: packages made in Year 01', week 6
- O**: assembly house ID; O means OSE, G means GR, ...
- B**: the IC version
- 1**: wafers manufactured in Winbond FAB I
- 1039050-21NA**: wafer production series number



Headquarters
 No. 4, Creation Rd. III
 Science-Based Industrial Park
 Hsinchu, Taiwan
 TEL: 886-35-770066
 FAX: 886-35-789467
 www: <http://www.winbond.com.tw/>

Taipei Office
 11F, No. 115, Sec. 3, Min-Sheng East Rd.
 Taipei, Taiwan
 TEL: 886-2-7190505
 FAX: 886-2-7197502
 TLX: 16485 WINTPE

Winbond Electronics (H.K.) Ltd.
 Rm. 803, World Trade Square, Tower II
 123 Hoi Bun Rd., Kwun Tong
 Kowloon, Hong Kong
 TEL: 852-27516023-7
 FAX: 852-27552064

**Winbond Electronics
 (North America) Corp.**
 2730 Orchard Parkway
 San Jose, CA 95134 U.S.A.
 TEL: 1-408-9436666
 FAX: 1-408-9436668

Please note that all data and specifications are subject to change without notice. All the trademarks of products and companies mentioned in this data sheet belong to their respective owners.

These products are not designed for use in life support appliances, devices, or systems where malfunction of these products can reasonably be expected to result in personal injury. Winbond customers using or selling these products for use in such applications do so at their own risk and agree to fully indemnify Winbond for any damages resulting from such improper use or sale.