



## GENERAL DESCRIPTION

The Integrated Multiple Port Repeater II (IMPR II) implements the repeater functions specified by section 9 of the IEEE 802.3 standard and twisted pair line transceiver functions conforming to the 10BASE-T standard. The IMPR II provides eight Twisted Pair (TP) Line Transceiver Ports and an Attachment Unit Interface (AUI) port. Each Twisted Pair (TP) Line Transceiver Port can connect to an Ethernet segment through a twisted pair line. The AUI port can connect to a thick Ethernet segment by means of a 50-meter AUI cable. The IMPR II provides an AUI/TP port status direct report function, which uses the ten port status pins and two select pins to indicate collisions, port link/activity, partition, polarity, and network utilization. The inter-IMPR II interface includes signals for connecting more than one IMPR II to increase the total number of hub ports. The manageable functions of the repeater and twisted pair line transceiver in the IMPR II can be accessed through a serial interface.

## FEATURES

- Functions conform to IEEE 802.3 section 9 specifications
- Single 5V power supply
- CMOS process for lower power dissipation
- Twisted-Pair (TP) line media interface compatible with 10 BASE-T specifications
- Differential interface compatible with AUI specifications
- Port status direct report function
- Asynchronous Inter-IMPR II interface for large hub applications
- Serial management interface allows for network management and makes port status information accessible
- AUI and TP port carrier sense signals observable through a port activity monitor port
- Internal main state machine performs fragment extension, packet repetition, and collision handling functions
- Internal jabber lockup protection state machine monitors the length of each input packet to prevent transmission of excessively large packets
- Separate partition state machine for each TP port and AUI port can isolate ports when an excessive number of collisions occur and reconnect them using certain algorithms
- On-chip PLL, Manchester encoder/decoder, and FIFO

## ORDERING INFORMATION

TYPE NO.	PACKAGE
W89C982AF	100-pin QFP

# Preliminary W89C982AF



## SYSTEM DIAGRAM

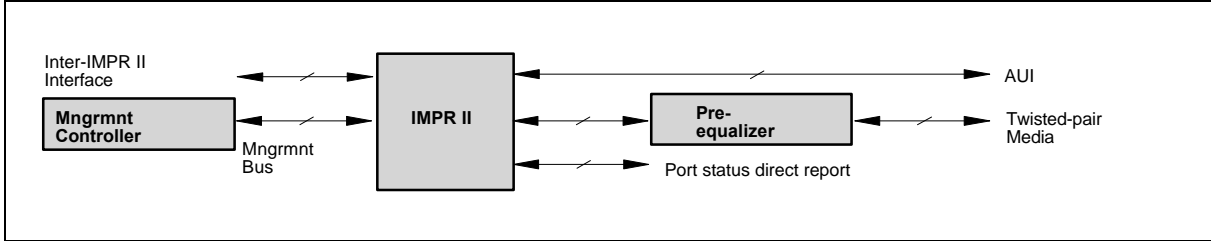

## PIN CONFIGURATION

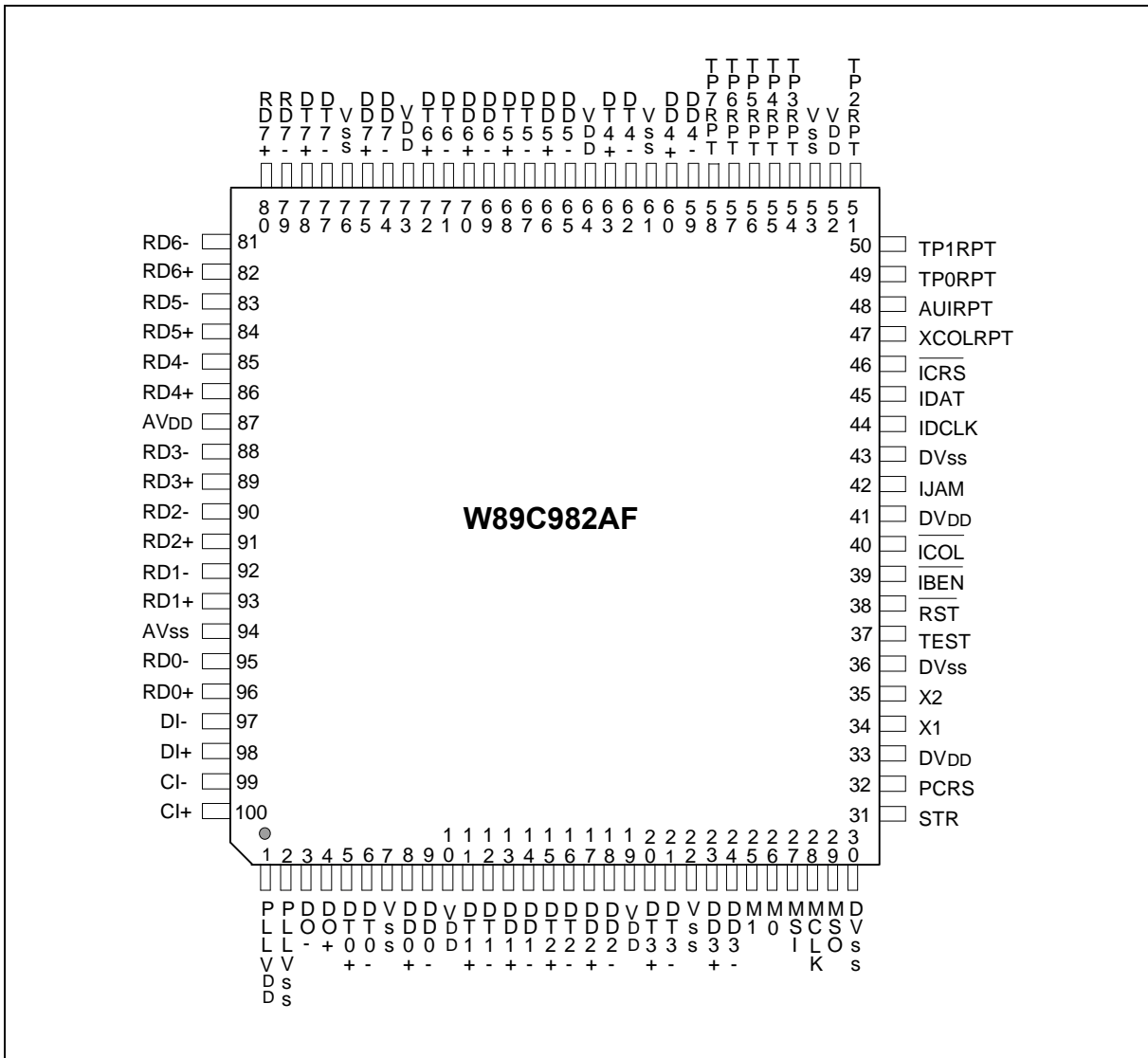



## PIN DESCRIPTION

NETWORK INTERFACE PINS			
NAME	NO.	I/O	DESCRIPTION
DO+ DO-	4 3	O	AUI Transmit Output: Differential line driver that sends differential signal to Medium Attached Unit (MAU). These pins require a 270 ohm pull-down resistor to GND.
DI+ DI-	98, 97	I	AUI Receive Input: Differential receiver that receives the AUI-compliant receive signal from MAU.
CI+ CI-	100, 99	I	AUI Collision Input: Differential receiver that receives the AUI-compliant collision signal from MAU.
DT0+ to DT7+	5, 11, 15, 20, 63, 68, 72, 78	O	Data Positive: Transmit data driver positive that transmits data on the twisted pair line. The driver will source or sink 32 mA. The driver is low during idle.
DT0- to DT7-	6, 12, 16, 21, 62, 67, 71, 77	O	Data Negative: Transmit data driver negative that transmits inverted data on the twisted pair line. The driver will source or sink 32 mA. Driver is low during idle.
DD0+ to DD7+	8, 13, 17, 23, 60, 66, 70, 75	O	Delayed Data Positive: Transmit data driver positive that transmits delayed inverted data on the twisted pair line. The driver will source or sink 32 mA. Driver is low during idle.
DD0- to DD7-	9, 14, 18, 24, 59, 65, 69, 74	O	Delayed Data Negative: Transmit data driver negative that transmits delayed data on the twisted pair line. The driver will source or sink 32 mA. Low during idle.
RD0+ to RD7+	96, 93, 91, 89, 86, 84, 82, 80	I	Twisted Pair Line Receive Positive: Positive data from the twisted pair line are received by the internal receiver through this pin.
RD0- to RD7-	95, 92, 90, 88, 85, 83, 81, 79	I	Twisted Pair Line Receive Negative: Negative data from the twisted pair line are received by the internal receiver through this pin.
INTER-IMPR II INTERFACE PINS			
ICRS	46	O	Inter-IMPR II Carrier Output: The inter-IMPR II carrier (an active low on this pin) will be present when the IMPR II is repeating packets. The IMPR IIs output this signal to the interface of inter-IMPR II for retransmitting valid packets or propogating network collision messages to other IMPR IIs.

# Preliminary W89C982AF



Continued

INTER-IMPR II INTERFACE PINS			
NAME	NO.	I/O	DESCRIPTION
$\overline{\text{IBEN}}$	39	I	Inter-IMPR II interface Enable: $\overline{\text{IBEN}}$ is driven by HUB integrator. The integrator will drive the $\overline{\text{IBEN}}$ low if there is only one IMPR II which outputs $\overline{\text{ICRS}}$ to the inter-IMPR II interface. The IMPR II that asserts $\overline{\text{ICRS}}$ will be allowed to transmit valid messages to the IMPR II integrator when $\overline{\text{IBEN}}$ is low.
$\overline{\text{ICOL}}$	40	I	Inter-IMPR II Collision: $\overline{\text{ICOL}}$ will be driven low when more than one IMPR II simultaneously output $\overline{\text{ICRS}}$ to the IMPR II integrator. The IMPR II will not transmit any data to the IMPR II integrator when $\overline{\text{ICOL}}$ is low. On this situation the collision messages will still be sent to all ports of the IMPR II.
IDCLK	44	I O	Inter-IMPR II Data Clock: IDCLK will drive a 10 MHz clock output when $\overline{\text{ICRS}}$ is asserted and $\overline{\text{IBEN}}$ is driven. If $\overline{\text{ICRS}}$ is not asserted and $\overline{\text{IBEN}}$ is driven, IDCLK will be driven by the IDCLK signal of another IMPR II. If a dumb hub is used, i.e., no $\overline{\text{IBEN}}$ is present, this pin is in high impedance. This pin is synchronous to IDAT data.
IDAT	45	I O Z	Inter-IMPR II Data: The IMPR II sends/receives valid packets or inter-port collision messages to/from other IMPR IIs through the IDAT pin in NRZ format. IDAT is in high-Z state during inter-IMPR II collisions or when the network is idle. IDAT remains high when there is a transmit collision in the IMPR II.
IJAM	42	I O Z	Inter-IMPR II IJAM: IJAM is driven low when a valid packet is being sent. IJAM is driven high when IDAT carries a collision message (i.e., always high or always low). IDAT = 0 indicates a multiport collision and IDAT = 1 indicates a single port collision condition. During inter-IMPR II collisions or when the network is idle, IJAM should be in high-Z state.
MANAGEMENT BUS PINS			
$\overline{\text{RST}}$	38	I	IMPR II Reset: The IMPR II will be forced into its initial state when $\overline{\text{RST}}$ is driven low.
MCLK	28	I	Management Bus Clock: The management data are clocked by MCLK serially. The rising edge of MCLK will latch the data into or out of the IMPR II.



Continued

<b>MANAGEMENT BUS PINS</b>																							
<b>NAME</b>	<b>NO.</b>	<b>I/O</b>	<b>DESCRIPTION</b>																				
MSI	27	I	Management Data in: The management command is serially clocked into IMPR II by MCLK.																				
MSO	29	O	Management Data Out: The network status or the internal management status of the IMPR II is serially read out from MSO whenever the IMPR II receives a status read command.																				
TEST	37	I	IMPR II Test Mode: This pin should be tied high during test mode and tied low during normal operations.																				
PCRS	32	O	Network Port Carrier Sense: The carrier sense signals for the IMPR II's internal logic from the AUI port and eight TP ports are serially sampled and output through PCRS. The output bits are stream synchronized to X1 clock.																				
STR	31	O	Network Port Carrier Sense Strobe: The serial bit stream on PCRS can be latched by an external latch using the STR signal. The STR goes high for two X1 clock cycles after the nine carrier sense bits are output through PCRS.																				
X1	34	I	System Clock Input: An external 20 MHz system clock source is connected to this pin to provide the operating clock. For crystal applications, a 20 MHz crystal may be connected across pins X1 and X2.																				
X2	35	O	Crystal Clock Feedback: Pin X2 should be left floating when an external clock source is used.																				
<b>PORT STATUS DIRECT REPORT INTERFACE PINS</b>																							
M1	25	I	Port Status Direct Report Select Pins: These two pins control the output status of the port status pins. Four output states can be selected by M1, M0: <table border="0" style="margin-left: 40px;"> <tr> <td>TP</td> <td>Link/Activity</td> <td>Partition</td> <td>Polarity error</td> <td>Utilization</td> </tr> <tr> <td>AUI</td> <td>COL/Activity</td> <td>Partition</td> <td>Loopback error</td> <td>Utilization</td> </tr> <tr> <td>M1</td> <td>0</td> <td>0</td> <td>1</td> <td>1</td> </tr> <tr> <td>M0</td> <td>0</td> <td>1</td> <td>0</td> <td>1</td> </tr> </table>	TP	Link/Activity	Partition	Polarity error	Utilization	AUI	COL/Activity	Partition	Loopback error	Utilization	M1	0	0	1	1	M0	0	1	0	1
TP	Link/Activity			Partition	Polarity error	Utilization																	
AUI	COL/Activity			Partition	Loopback error	Utilization																	
M1	0			0	1	1																	
M0	0	1	0	1																			
M0	26																						
XCOL-RPT	47	O	Collision Status Direct Report Output: Whenever a collision event occurs, this pin is active high. This pin drives a TTL data buffer, which directly drives an LED.																				

# Preliminary W89C982AF



Continued

PORT STATUS DIRECT REPORT INTERFACE PINS			
NAME	NO.	I/O	DESCRIPTION
AUI - RPT	48	O	AUI Port Status Direct Report Output: This pin outputs the AUI port status selected by M0/M1. This pin drives a TTL data buffer, which directly drives an LED.
TP0 - RPT	49-51,	O	TP Port Status Direct Report Output: These pins output the TP port status selected by M0/M1.
TP7 - RPT	54-58		These pins drive a TTL data buffer, which directly drives an LED.
POWER GROUND PINS			
VDD	10, 19, 52, 64, 73	I	Power Supply for TP Transmit/Port Status Pins: +5V DC power supply.
VSS	7, 22, 53, 61, 76	I	Ground for TP Transmit/Port Status Pins.
AVDD	87	I	TP Receive Power Supply: +5V DC power supply. This pin should be decoupled with a 22 $\mu$ F capacitor and kept separate from other power and ground planes.
AVSS	94	I	TP Receive Ground: Grounding pins.
PLL - VDD	1	I	PLL Power Supply: +5V DC power supply. This pin should be decoupled with a 22 $\mu$ F capacitor and kept separate from other power and ground planes.
PLL - VSS	2	I	PLL Ground: Grounding pins.
DVDD	33, 41	I	Digital Power Supply: +5V DC power supply.
DVSS	30, 36, 43	I	Digital Ground: Grounding pins.

## BLOCK DIAGRAM

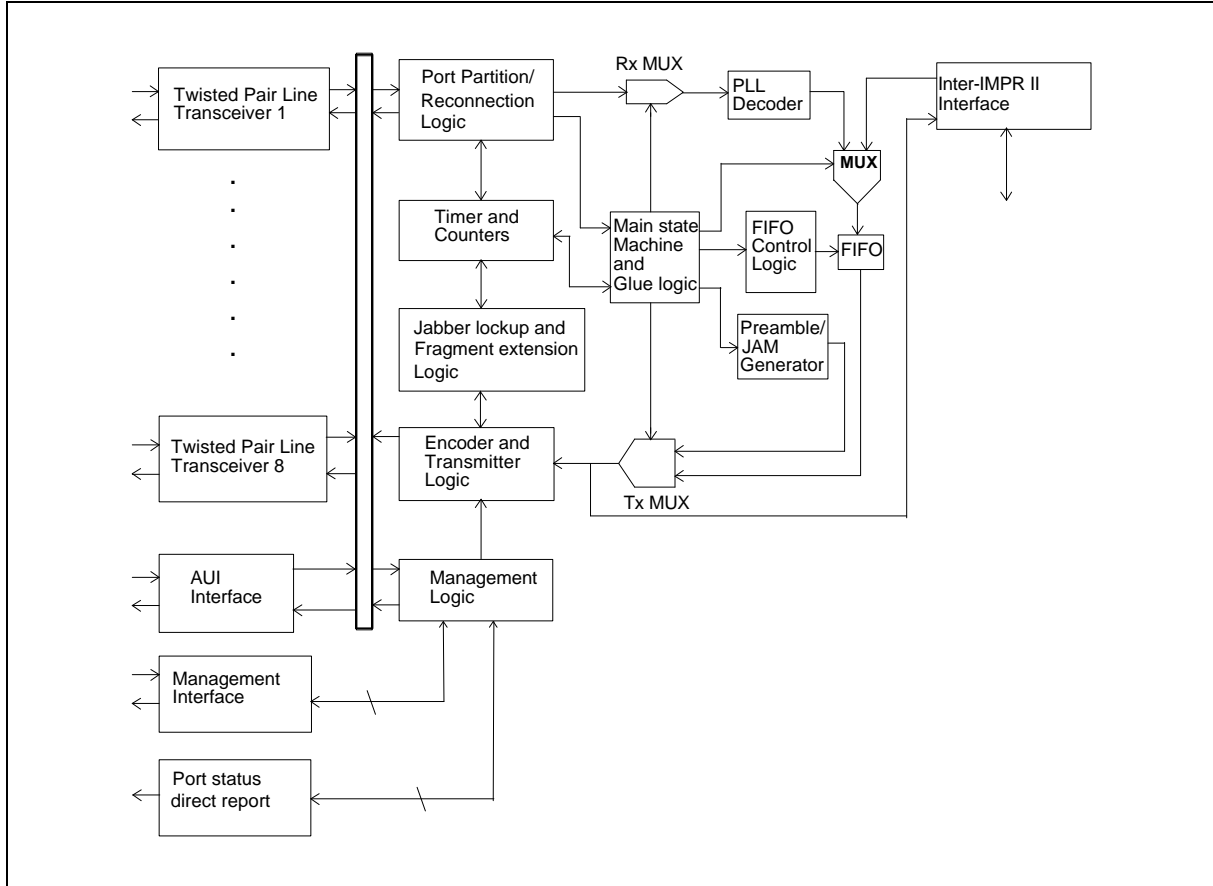

## FUNCTIONAL DESCRIPTION

The Integrated Multiple Port Repeater II implements the functions stipulated in the IEEE repeater specifications, the functions specified by 10BASE-T standards, and functions for network management. It provides an Inter-IMPR II interface to allow implementation of a repeater set with more network ports. The block functions of the IMPR II are described below.

### AUI Interface and Twisted Pair Line Transceiver

The AUI provides an interface for an external Medium Attached Unit (MAU) connected to the IMPR II. The IMPR II can be used to connect a 10BASE2 or 10BASE5 Ethernet to a 10BASE-T Ethernet via a coaxial transceiver. The Twisted Pair Line Transceiver provides the interface used to connect IEEE 802.3 LAN stations (Data Terminal Equipment, or DTEs) into Ethernet networks constructed from twisted pair media. The Twisted Pair Line Transceiver also contains a link test function and autopolarity reversal function for wiring detection.

### Link Test Function

The link test function of the TP port is used to check whether the TP port is linked to an active TP port. The TP port will enter link fail state if it does not receive any packets or link test pulses for more than 60 mS, until it receives either six consecutive link pulses or a packet. When the TP port is in link



fail state, the IMPR II will not transmit any signal (packets or link pulses) on the TP port and the first input packet will not be retransmitted. The IMPR II will transmit link test pulses to any TP port after the transmitter of the TP port has been inactive for more than 16 mS after the TP port enters link good state. The link test function of the TP port is user-programmable using the management functions of the IMPR II. The TP port is forced into link good status if the link test function is disabled. The link test function is enabled by default each time the IMPR II is reset.

## Automatic Polarity Reversal Function

The automatic polarity reversal function checks the polarity of the input data packets or link pulses. The polarity of the TP port will be set to negative when the polarity of the first input packet or the first three consecutive link pulses following reset or following entry of the TP port into link fail state are detected to be negative. Once the polarity of the TP port is set to negative, all consequent input packets will be retransmitted with data that are inverted with respect to the input packet after the TP port enters link good state. If the polarity of the TP port is not set to negative, all input packets will be retransmitted without any modification of the data polarity. Once the polarity of the TP port is determined, the polarity of this port will not be updated until the IMPR II is either reset or re-enters link fail state, regardless of whether the automatic polarity reversal function is disabled or enabled. The automatic polarity reversal function is user-programmable using the management functions of the IMPR II and is enabled by default each time the IMPR II is reset. The default status of polarity is "correct" when the IMPR II is in reset state.

## Port Partition/Reconnection Logic

The port partition/reconnection logic implements the segment partitioning algorithm and the segment reconnection algorithm. These algorithms are defined by IEEE specifications and are used to protect the network from malfunctioning segments. There are nine partition/reconnection machines in an IMPR II. Each port partition reconnection machine controls an individual network port.

A network port will be partitioned by the IMPR II when either of the following conditions is detected:

- (1) A collision condition exists continuously for a period of up to 1024 bit times.
- (2) Thirty-two consecutive collisions occur.

A collision condition is defined as more than two network ports attempting to transmit simultaneously or as a receive collision from the AUI.

The IMPR II can reconnect a partitioned network port using algorithms selected by programming the management logic. The following are the two reconnection algorithms:

- (1) Standard reconnection algorithm:

A partitioned network port will be reconnected if a data packet longer than 512 bit times is retransmitted to or received from that port without collision.

- (2) Alternative reconnection algorithm:

A partitioned network port will be reconnected if a data packet longer than 512 bit times is retransmitted to that port without collision.

The reconnection algorithms for all the TP ports and the AUI port are programmed individually; however, all the TP ports use the same algorithm. The standard algorithm is selected by default each time the IMPR II is reset.

## Port Status Direct Report Function

# Preliminary W89C982AF



The IMPR II provides one pin (XCOLRPT) for collision status report, two pins (M0/M1) for port status report mode selection, and nine pins for port status report (AUIRPT, TP0-7RPT). XCOLRPT is active when a collision occurs. Each of the nine port status report pins can directly report four aspects of the port status. Which aspect of the network status is reported by these pins is determined by the two mode selection pins, M1 and M0, as shown in the table below.

	TP LINK/ACTIVITY AUI COL/ACTIVITY	PARTITION	TP POLARITY AUI LOOPBACK ERROR	UTILIZATION UTILIZATION
<b>M1</b>	0	0	1	1
<b>M0</b>	0	1	0	1

When M0 and M1 are set to "0," the pins report TP link/activity and AUI COL/activity. In this mode, a low output on AUIRPT and TP0-7RPT means all the TP ports are in the link fail state, a high means all the TP ports are in link good state, and the AUI is in collision state, and a 10 Hz signal means incoming packets are being received by the AUI/TP ports. (Note that the 10 Hz signal is still reported if the ports are partitioned or disabled.) If M0 is set to "1" and M1 to "0," the port partition status will be reported. In this mode, a "0" output means that all the ports are connected correctly, and a "1" means that the AUI/TP ports are in a partition state. When M0 is set to "0" and M1 to "1," AUI loopback errors and TP polarity status will be reported. In this mode, a "0" output means that the AUI loopback and TP polarity are correct, and a "1" means that an AUI loopback error has been detected and the TP port polarity is reversed. If M0 and M1 are both set to "1," the network utilization will be reported. In this mode, each LED stands for 10% of utilization. The percentage of network utilization is shown the following table.

% OF UTILIZATION	AUI LED	TP0 LED	TP1 LED	TP2 LED	TP3 LED	TP4 LED	TP5 LED	TP6 LED	TP7 LED
10%	v								
30%	v	v	v						
50%	v	v	v	v	v				
90%	v	v	v	v	v	v	v	v	v

Using pins M1 and M0 and external transistors, the IMPR II can drive LEDs to indicate the status of the AUI/TP ports sequentially; the application circuit for the LEDs is shown below. If a simple decoder is connected to pins M1 and M0 and a switch circuit is connected to TP0RPT to TP7RPT, the TP port link/activity, partition, polarity, and network utilization can be displayed simultaneously.

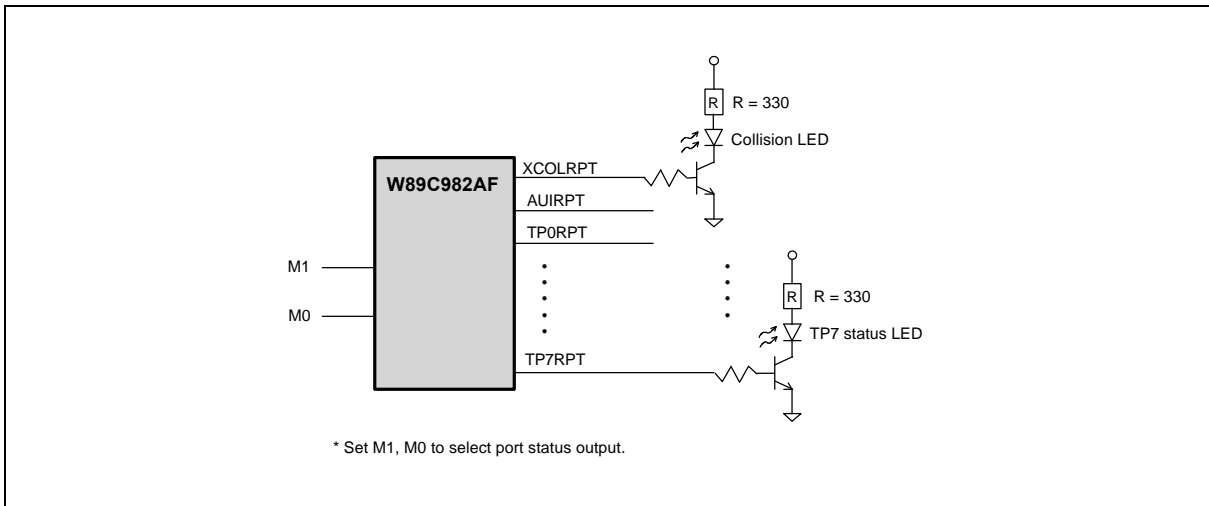

## Initial State After Reset

When  $\overline{\text{RST}}$  is driven low, the IMPR II is reset. The minimum time the reset signal must be held low to trigger a reset is 100  $\mu\text{s}$ . During reset, the IMPR II places all outputs in the inactive state (except for the auto polarity reversal function). Active low outputs stay high, active high outputs stay low, link test is enabled, and the TP link is in a fail state. The AUI/TP auto partition/reconnection uses the standard algorithm, AUI/TP transmitters are idle, AUI/TP receivers are enabled, IDAT and IJAM are in high-impedance state, STR is low, and the auto polarity reversal function is enabled.

## Management Logic and Management Interface

The major functions of the management logic are enabling/disabling networks, partitioning/reconnecting network ports, enabling/disabling the link test and autopolarity reversal functions of the twisted pair line transceiver, and accessing the link status and polarity status of the twisted pair line transceiver. The management interface is a signal bus that contains input/output signals to/from the management logic and the internal carrier sense signals for the nine network ports of the IMPR II.

The management logic can accept and execute management commands when the IMPR II is in normal mode, i.e., the TEST pin of the IMPR II is tied low. All management commands are byte-oriented and are clocked into the IMPR II serially by an external clock. Some of the commands require an output from the IMPR II in response and some do not. At least 20 clocks are required to send a command that requires an output response from the IMPR II; 14 clocks are needed to send a command that requires no response. The serial command data stream and any associated output response data stream are structured in a manner compatible with the RS232 serial data format, i.e., one start bit followed by eight data bits, with the LSB sent first and the MSB last.

# Preliminary W89C982AF



The following table summarizes the management commands. The LSBs of both the MSI data and the MSO data are shown on the right and the MSBs are shown on the left. Each command is described in more detail below.

MSI INPUT DATA	MSO READ DATA	FUNCTIONS
11010000	P7 . . . P0	Read link test status of TP ports
11100000	P7 . . . P0	Read polarity status of TP ports
10000000	P7 . . . P0	Read partition status of TP ports
10001111	P7 . . . P0	Read bit rate error status of TP ports
11110000	M0000000	Read MJLP status
10001111	PBSL0000	Read AUI port status (B, S, L cleared)
10001011	PBSL0000	Read AUI port status (S, L cleared)
10001101	PBSL0000	Read AUI port status (B cleared)
10001001	PBSL0000	Read AUI port status (None cleared)
00111111	None	Enable AUI port
00101111	None	Disable AUI port
00110bbb	None	Enable TP ports
00100bbb	None	Disable TP ports
01010bbb	None	Enable TP port link test function
01000bbb	None	Disable TP port link test function
01110bbb	None	Enable TP ports auto polarity reversal function
01100bbb	None	Disable TP ports auto polarity reversal function
00011111	None	Set AUI port alternate reconnection algorithm
00010000	None	Set TP port alternate reconnection algorithm
00001CSA	None	Set IMPR II programmable option

## Read Link Test Status of TP Ports

The link test status of all eight TP ports can be read using this command. Bits 0 through 7 correspond to the link test status of TP ports 0 through 7. A "1" on the MSO bit indicates "Link Good" status and a "0" indicates "Link Fail" status.

## Read Polarity Status of TP Ports

The polarity status of all eight TP ports can be read using this command. Bits 0 through 7 correspond to the polarity status of TP ports 0 through 7. A "1" on the MSO bit indicates reversed polarity and a "0" indicates positive polarity.

## Read Partition Status of TP Ports

**The partition status of all eight TP ports can be read using this command. Bits 0 through 7 correspond to the polarity status of TP ports 0 through 7. A "1" on the MSO bit indicates a connected status and a "0" indicates a partitioned status.**



## Read Bit Rate Error Status of TP Ports

The bit rate error status of the TP ports can be read using this command. Bits 0 through 7 correspond to the polarity status of TP ports 0 through 7. A "1" on the MSO bit indicates that a bit rate error has occurred and a "0" indicates no bit rate error has occurred.

## Read MJLP Status

The MAU jabber lock-up protection status can be accessed using this command. A "1" on the MSB indicates the transmit function of the IMPR II has been inhibited. The status can also be cleared using this command.

## Read AUI Port Status

The AUI port status, including partition, bit rate error, SQE test, and loopback error, can be accessed using different variations of this command. Four different specific commands can be used, as shown in the following table.

MSI DATA	MSO DATA	CLEAR BITS
10001111	PBSL0000	B, S, L read cleared. P not cleared.
10001011	PBSL0000	S, L read cleared. P, B not cleared.
10001101	PBSL0000	B read cleared. P, S, L not cleared.
10001001	PBSL0000	P, B, S, L not cleared.

## Enable AUI Port

When disabled, the AUI port can be re-enabled using this command. The AUI port will then carry out normal transmitting and receiving operations. To reconnect a partitioned AUI port, the port must first be disabled and then re-enabled using this command.

## Disable AUI Port

This command is used to disable the AUI port. When the AUI port is disabled, all inputs (the carrier sense and the SQE) to the AUI port will be ignored by the IMPR II and the IMPR II will not transmit any signal on the AUI port. In addition, the partition machine for the AUI port will be forced into idle status.

## Enable TP Ports

This command is used to enable a disabled TP port, allowing it to perform normal transmitting and receiving operations. To reconnect a partitioned TP port or force a TP port into link fail state, the port must first be disabled and then re-enabled using this command.

## Disable TP Ports

Each TP port can be disabled individually. Bits 0, 1, and 2 are used to indicate the TP port that is to be disabled, as follows:



B2	B1	B0	TP PORT DISABLED
0	0	0	TP0
0	0	1	TP1
0	1	0	TP2
0	1	1	TP3
1	0	0	TP4
1	0	1	TP5
1	1	0	TP6
1	1	1	TP7

When a TP port is disabled, all inputs (the carrier sense) to that port will be ignored by the IMPR II and the IMPR II will not transmit any signal on the port. The partition machine for the port will be forced into the idle state and the link test will indicate that the port is in the "Link Fail" state.

### Enable TP Port Link Test Function

This command is used to re-enable a link-test disabled TP port. Using this command on a TP port that is already enabled will have no effect on the port.

### Disable TP Port Link Test Function

The TP port link test function can be enabled or disabled port-by-port. Bits 0, 1, and 2 are used to select which TP port is to be disabled in the manner described under the "Disable TP ports" command above. Once the link test function is disabled, the TP port will not enter the link fail state.

### Enable TP Port Auto Polarity Reversal Function

The auto polarity reversal function of the TP ports can be enabled or disabled port-by-port. Bits 0, 1, and 2 are used to indicate which TP port is to be enabled, in the manner described under the "Disable TP ports" command above. When the auto polarity reversal function is enabled, the TP port will check the polarity of input packets once it enters the link fail state. This function is enabled by default each time the IMPR II is reset.

### Disable TP Port Auto Polarity Reversal Function

This command is used to disable the auto polarity reversal function of a TP port so that the port will no longer check the polarity of input packets. If an input packet with reversed data is received, the IMPR II will not correct the polarity and retransmit the packet to all the network ports. In this case, failure to reverse the polarity may cause a network error.

### Set AUI Port Alternative Reconnection Algorithm

The partition/reconnection scheme can be programmed for the alternative (transmit only) reconnection algorithm using this command. To return the partition/reconnection logic of the AUI port back to the standard reconnection (transmit or receive) algorithm, the IMPR II must be reset.

### Set TP Port Alternative Reconnection Algorithm

The partition/reconnection scheme can be programmed for the alternative (transmit only) reconnection algorithm using this command. To return the partition/reconnection logic of a TP port back to the standard reconnection (transmit or receive) algorithm, the IMPR II must be reset.



The other main function of the management logic is the port activity monitoring function. The internal carrier sense signal of all network ports is sampled out serially. The accuracy of the carrier sense signals is 10 bit times. The first bit samples the internal carrier sense signal of the AUI port, the second bit samples TP0, the third bit samples TP1, and so forth. The tenth bit time is idle, and a strobe signal will be active during the tenth bit time. With the help of the strobe signal, the serial sampled carrier sense signal can be latched to a serial-to-parallel shifter.

## IMPR II Programmable Options

Three IMPR II programmable options can set by this command via the appropriate bit in MSI data. The three programmable options are CI reporting, AUI SQE test mask, and alternative port activity monitor function, which correspond to bits C, S, and A, respectively.

### CI Reporting

Setting bit C = 1 will alter the function of the STR pin. STR will become an input pin for repeater management devices and PCRS will insert the CI bit immediately before the AUI bit.

### AUI SQE Test Mask

Setting S = 1 will disable the AUI SQE test when the SQE signal is within the SQE test window and no jam pattern will be asserted after transmitted packets. The SQE test window is from 6 bit times to 34 bit times. When the SQE signal is larger than the SQE test window, a collision condition has occurred.

### Alternative Port Activity Monitor

Setting A = 1 will enable the alternative PAM function, so that repeater management devices can monitor the status of each port using the unmodified PCRS signal.

## The IMPR II Kernel Logic

The kernel logic of the IMPR II includes a main state machine and glue logic, timers and counters, jabber lockup and fragment extension logic, a PLL decoder, encoder and transmitter, a 64-bit FIFO with FIFO control logic, and a preamble/jam generator. These blocks perform most of the operations needed to fulfill the requirements of the IEEE repeater specification. When a packet is received by a connected port, it is sent via the receive multiplexer to the PLL decoder. Data and collision status are sent to the main state machine via the port partition/reconnection logic. This enables the main state machine to determine the source of data to be repeated and the type of data to be transmitted. The transmit data may be either the received packet's data field or a preamble/jam pattern consisting of a 1010... bit pattern.

Associated with the main state machine are a series of timers and counters which ensure that various IEEE specification times (referred to as the TW1 to TW6 times) are fulfilled. The PLL decoder decodes the received data from Manchester code format into NRZ format and recovers the jitter accumulated over the receiving segment.

The preamble/jam generator and the FIFO compensate for the preamble bit loss caused by receptions by the twisted pair line transceiver. The FIFO is used to store the bits of the data field temporarily while the preamble/jam generator is sending the preamble of the transmitting packet. A 1010... jam pattern is generated under network collision conditions.

The jabber lockup and fragment extension logic monitors the retransmitted packet. A jam pattern will be appended to short packets (less than 96 bits in length) to extend them to a full 96 bits. The jabber



lockup and fragment extension logic will inhibit the encoder/transmitter logic when the retransmitted packet is more than 65536 bits in length.

Packet repetition and network collision handling are performed by the main state machine according to IEEE specifications. Soon after the network port receiving data packet has been identified, the main state machine enables the preamble/jam generator to generate a preamble pattern onto the encoder/transmitter. While the preamble is being transmitted, the received data are still being monitored. The main state machine will enable the FIFO control logic to read the valid data into the FIFO when the start of frame delimiter "SFD" is detected. A 1011 bit pattern is filled into the FIFO before the SFD is detected. Removal of the FIFO data begins after a 60-bit preamble pattern has been sent.

## Inter-IMPR II Interface

The inter-IMPR II interface are designed for large hub applications. The inter-IMPR II interface allows a minimum of four IMPR IIs to be integrated together to implement a hub with 32 twisted pair line ports and four AUI ports. An external integrator is needed to handle the IMPR IIs. The data transfers on the inter-IMPR II interface are in NRZ format and certain signals are used to indicate the network status. Signals included on the inter-IMPR II interface allow the IMPR IIs to cooperate with each other in an appropriate manner. Those signals include IDAT, IDCLK, IJAM,  $\overline{\text{ICRS}}$ ,  $\overline{\text{IBEN}}$ , and  $\overline{\text{ICOL}}$ . The  $\overline{\text{ICRS}}$ ,  $\overline{\text{IBEN}}$ ,  $\overline{\text{ICOL}}$ , IJAM, are the control signals. The IDAT and IDCLK are used to transmit or receive data when the IMPR II asserts  $\overline{\text{ICRS}}$  and the external integrator asserted  $\overline{\text{IBEN}}$  and deasserted  $\overline{\text{ICOL}}$  to each IMPR II. The IDAT and IDCLK transmit data and a 10 MHz clock to the IMPR II integrator. When the IMPR II has not asserted  $\overline{\text{ICRS}}$  and the integrator has asserted  $\overline{\text{IBEN}}$  and deasserted  $\overline{\text{ICOL}}$  to each IMPR II, the IMPR II receives the data and a 10 MHz clock from IDAT and IDCLK. When IJAM is asserted, it indicates that a single port collision (IDAT = 1) or a multiport collision (IDAT = 0) is occurring.

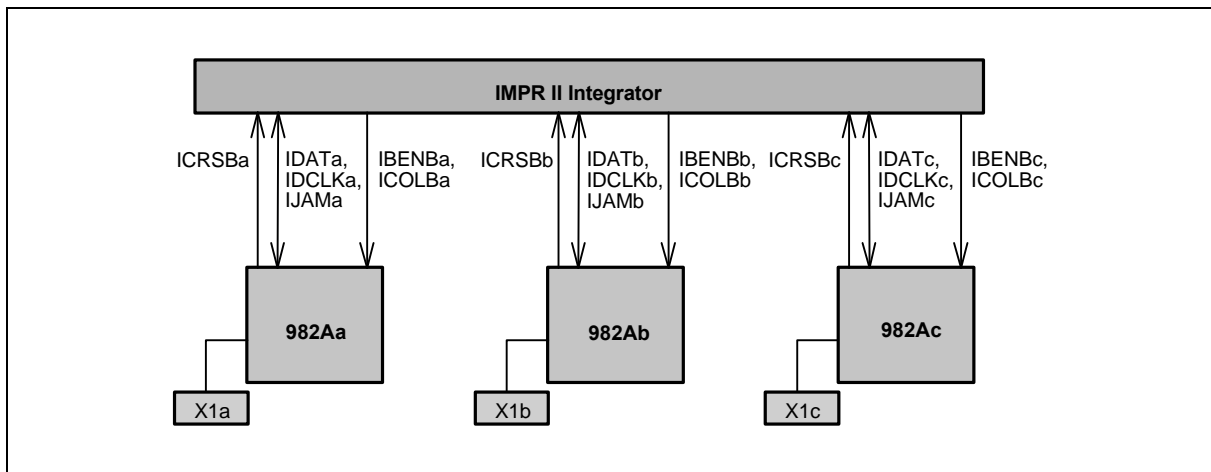

The figure above depicts an inter-IMPR II application circuit. The circuit requires an external inter IMPR II integrator. The external integrator integrated the  $\overline{\text{ICRS}}$  signal from each IMPR II and generates signals,  $\overline{\text{IBEN}}$  and  $\overline{\text{ICOL}}$ , to the IMPR II. Each IMPR II checks  $\overline{\text{IBEN}}$ ,  $\overline{\text{ICOL}}$  to handle the IDAT, IDCLK, IJAM signal direction.

Note that the inter-IMPR II uses different clocks source (X1a, X1b, X1c, etc.) to construct a large scale repeater application.

# Preliminary W89C982AF



## ABSOLUTE MAXIMUM RATINGS

PARAMETER	SYM.	MINIMUM	MAXIMUM	UNIT
Operating Temperature	TA	0	70	°C
Storage Temperature	TS	-55	150	°C
Supply Voltage	VDD	-0.5	7.0	V
Input Voltage	VIN	VSS -0.5	VDD +0.5	V
Output Voltage	VOUT	VSS -0.5	VDD +0.5	V
Lead Temperature (soldering 10 seconds maximum)	Tl	-55	250	°C

Note: Exposure to conditions beyond those listed under Absolute Maximum Ratings may adversely affect the life and reliability of the device.

## Power Supply

(VDD = 4.75 to 5.25V, VSS = 0V, TA = 0° C to 70° C)

PARAMETER	SYMBOL	TYPICAL	MAXIMUM	UNIT
Power Supply Current (idle)	IDDI	-	100	mA
Power Supply Current (transmitting with no TP load)	IDDT	-	300	mA
Power Supply Current (transmitting with TP load)	IDDL	-	Note	mA

Note: For a TP typical load, each TP port will require an additional IDD current (maximum 32 mA). Less than 20% of the power will be dissipated by the IMPR II, the remaining power is dissipated by the external TP load.

## DC CHARACTERISTICS

(VDD = 4.75V to 5.25V, VSS = 0V, TA = 0° C to 70° C)

### Digital

PARAMETER	SYMBOL	MINIMUM	MAXIMUM	UNIT
Low Input Voltage	VIL	VSS -0.5	0.8	V
High Input Voltage	VIH	3.85	VDD +0.5	V
High Output Voltage (VDD = 4.5V)	VOL		0.4	V
High Output Voltage (VDD = 4.5V)	VOH	2.4		V
Input Leakage Current (Note 1)	IIL1		10	μA
Input Current (Note 2)	IIL2		500	μA
Output Leakage Current (VDD = 5.5V)	IOL		10	μA

Notes:

- All of the input pins except those stated in Note 2.
- TEST, IBENB, ICOLB, MSI, X1, M0, M1, these pins had been pull low or pull high.

www.DataSheet4U.com

Publication Release Date: November 1996

Revision A1

# Preliminary W89C982AF



## AUI

PARAMETER	SYM.	MIN.	MAX.	UNIT
Input Current at CI+/-, DI+/- pairs	I <sub>IA</sub>		2	mA
Differential Output Voltage (DO+/-)	V <sub>DD</sub>	+/-550	+/-1200	mV
Differential Output Voltage Imbalance (DO+/-)	V <sub>OB</sub>		40	mV
Undershoot Voltage (DO+/-)	V <sub>U</sub>		100	mV
Differential Squelch Threshold (CI+/-, DI+/-)	V <sub>DS</sub>	-175	-300	mV
Differential Input Common Mode Voltage (DI+/-, CI+/-)	V <sub>CM</sub>	1	4.0	V

## Twisted Pair

PARAMETER	SYM.	MIN.	TYP.	MAX.	UNIT
Power Supply Voltage	V <sub>DD</sub>	4.5	5.0	5.5	V
Input Voltage	V <sub>IN</sub>	-0.3		V <sub>DD</sub> +0.3	
RD+/- Differential Input Resistance	R <sub>TI</sub>			10	KΩ
RD+/- Differential Input Voltage (V <sub>DD</sub> = 5V)	V <sub>TIV</sub>	±0.3		±3.1	V
RD+/- Squelched Threshold	V <sub>TPS</sub>	±300	±400	±585	mV
RD+/- low Squelched Threshold	V <sub>TPU</sub>	±150	±220	±300	mV
RD+/- Input Switching Threshold	V <sub>RDT</sub>	±5	±10	±20	mV
DT+, DT-, DD+, DD- Imbalance Voltage	V <sub>TDU</sub>			±40	mV
DT+, DT-, DD+, DD- High Output Voltage	V <sub>TOH</sub>	V <sub>DD</sub> TP -0.44		V <sub>DD</sub> TP	V
DT+, DT-, DD+, DD- Low Output Voltage (I = 32 mA)	V <sub>TOL</sub>	V <sub>SS</sub> TP		V <sub>DD</sub> TP +0.44	V
DT+, DT-, DD+, DD- Output Current	I <sub>TO</sub>		32		mA
DT+, DT-, DD+, DD- Output Resistance	R <sub>TO</sub>		5	8	Ω
Pad Capacitance	CLD		7	10	pF



## AC CHARACTERISTICS

(V<sub>DD</sub> = 4.75V to 5.25V, V<sub>SS</sub> = 0V, T<sub>A</sub> = 0° C to 70° C)

### System Clock Timing

NO.	DESCRIPTION	FIG.	MIN.	TYP.	MAX.	UNIT
1	X1 clock rising time	1			10	nS
2	X1 clock falling time	1			10	nS
3	X1 clock period	1	49.995		50.005	nS
4	X1 clock high	1	22.5		27.5	nS
5	X1 clock low	1	22.5		27.5	nS

### System Clock Timing Diagram

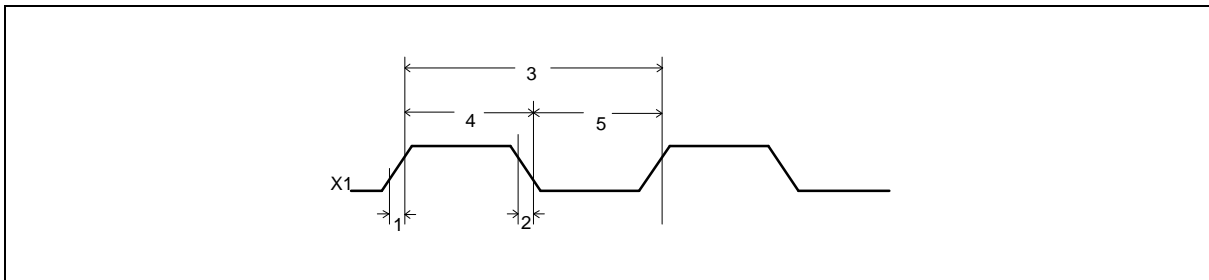

Figure 1

### Reset Timing

NO.	DESCRIPTION	FIG.	MIN.	TYP.	MAX.	UNIT
1	Reset pulse width	2	100			μS
2	$\overline{\text{RST}}$ Low hold time with respect to X1 clock	2	5			nS
3	$\overline{\text{RST}}$ High setup time with X1 clock rising time	2	20			nS

### Reset Timing Diagram

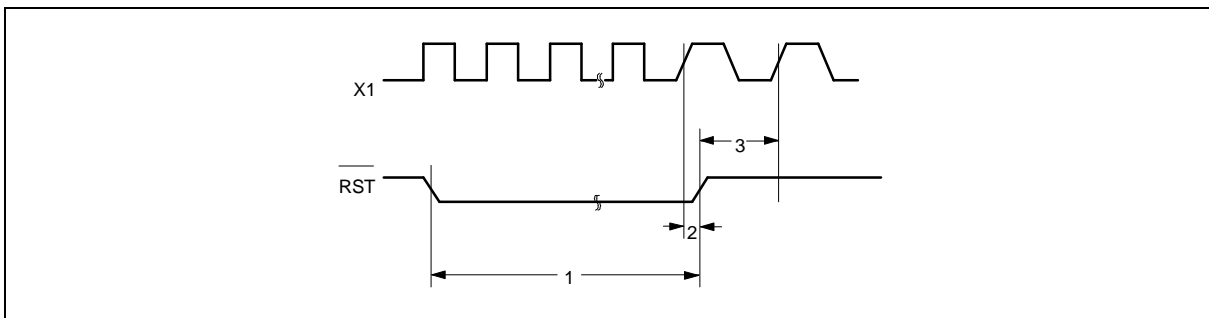

Figure 2

## Management Bus Clock Timing

NO.	DESCRIPTION	FIG.	MIN.	MAX.	UNIT
1	MCLK Clock Rising Time	3		10	nS
2	MCLK Clock Falling Time	3		10	nS
3	MCLK Clock Period	3	100		nS
4	MCLK Clock High	3	30		nS
5	MCLK Clock Low	3	30		nS
6	MSI Input Data Setup Time with Respect to MCLK Rising Edge	3	10		nS
7	MSI Input Data Hold Time with Respect to MCLK Rising Edge	3	10		nS
8	MSO Output Data Delay with Respect to MCLK Rising Edge	3		40	nS

## Management Bus Clock Timing Diagram

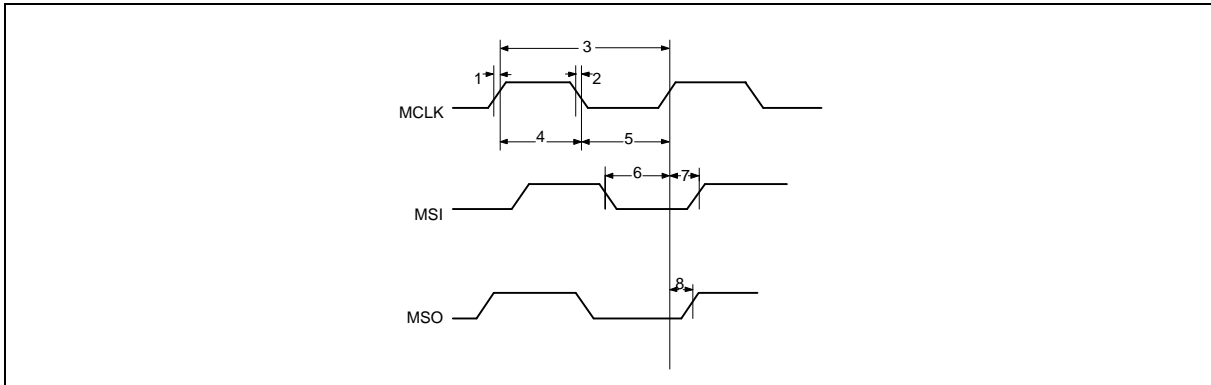

Figure 3

## Management Bus Carrier Sense Timing

NO.	DESCRIPTION	FIG.	MIN.	TYP.	MAX.	UNIT
1	X1 Rising Edge to STR High	4			40	nS
2	X1 Rising Edge to STR Low	4			40	nS
3	X1 Rising Edge to Valid PCRS	4			40	nS

## Management Bus Carrier Sense Timing Diagram

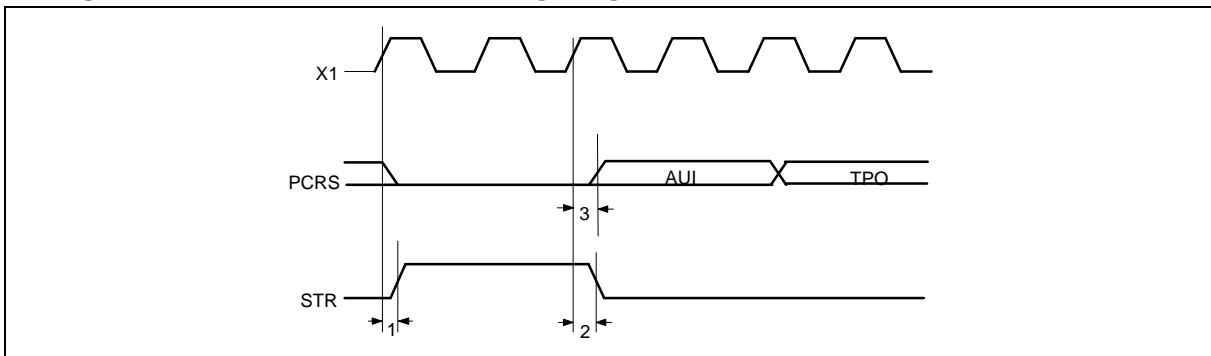

Figure 4



## Inter-IMPR II Interface Input Timing

NO.	DESCRIPTION	FIG.	MIN.	TYP.	MAX.	UNIT
1	Receive-in IDAT/IJAM setup time to receive-in IDCLK rising	5	20			nS
2	Receive-in IDAT/IJAM hold time from receive-in IDCLK rising	5	20			nS

## Inter-IMPR II Interface Input Timing Diagram

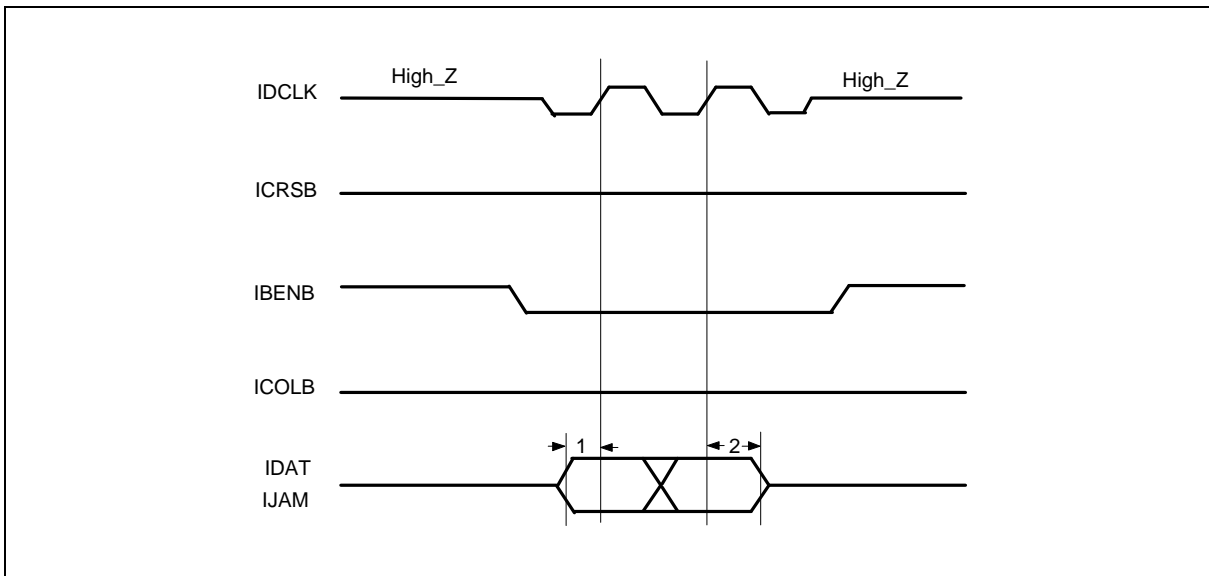

Figure 5

## Inter-IMPR II Interface Output Timing

NO.	DESCRIPTION	FIG.	MIN.	TYP.	MAX.	UNIT
1	$\overline{\text{ICRS}}$ asserted to $\overline{\text{IBEN}}$ asserted	6			35	nS
2	$\overline{\text{ICRS}}$ deasserted to $\overline{\text{IBEN}}$ deasserted	6			35	nS
3	Transmit-out IDAT/IJAM setup time to transmit-out IDCLK rising	6	30			nS
4	Transmit-out IDAT/IJAM hold time from transmit-out IDCLK rising	6	30			nS

## Inter-IMPR II Interface Output Timing Diagram

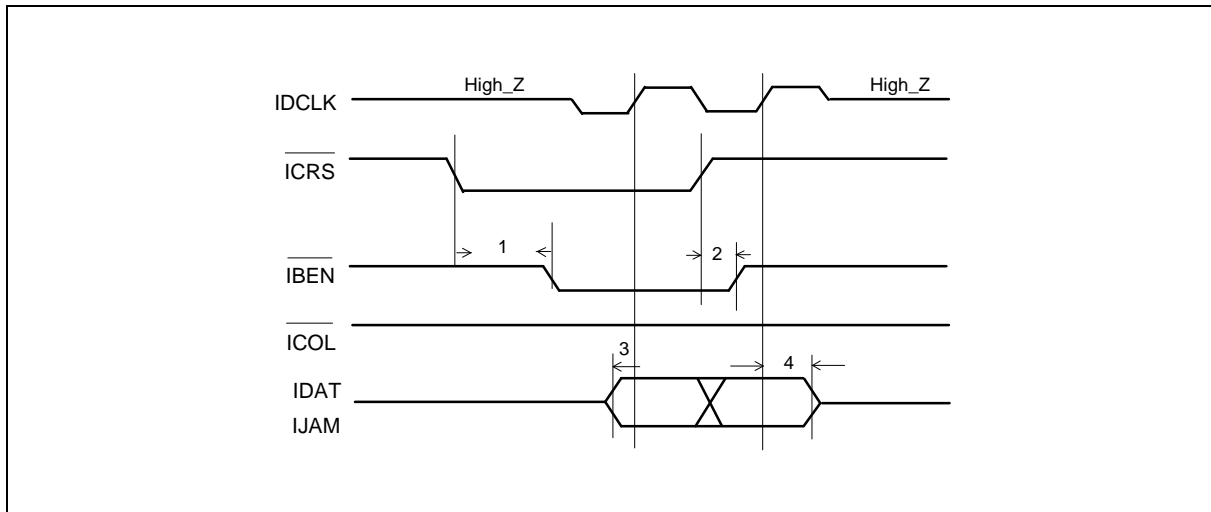

Figure 6



## Inter-IMPR II Interface Collision Timing

NO.	DESCRIPTION	FIG.	MIN.	TYP.	MAX.	UNIT
1	$\overline{\text{ICRS}}$ asserted to $\overline{\text{ICOL}}$ assertion	7			35	nS
2	$\overline{\text{ICRS}}$ deasserted to $\overline{\text{ICOL}}$ deassertion	7			35	nS

## Inter-IMPR II Interface Collision Timing Diagram

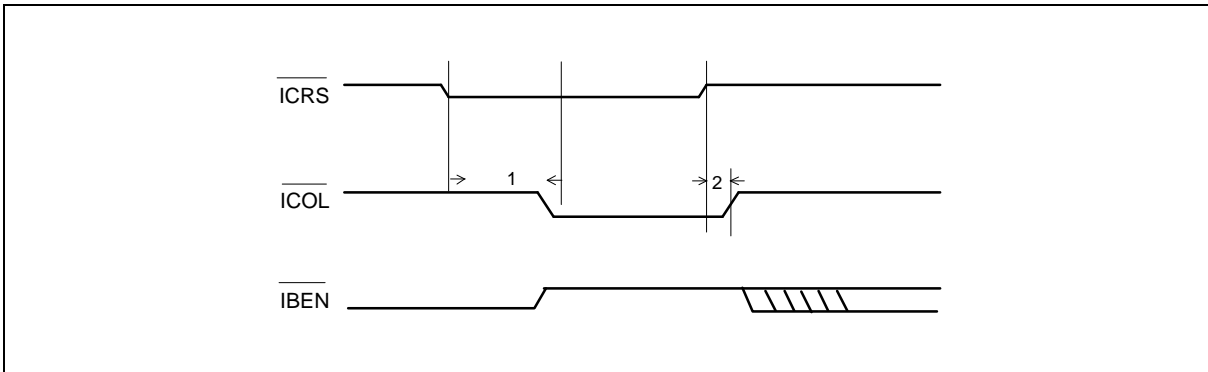

Figure 7

## Inter-IMPR II Interface to AUI/TP Port Timing

NO.	DESCRIPTION	FIG.	MIN.	TYP.	MAX.	UNIT
1	Inter-IMPR II Interface to AUI Propagation Delay	8		5		Bits
2	Inter-IMPR II Interface to TP Propagation Delay	8		5		Bits

## Inter-IMPR II Interface to AUI/TP port Timing Diagram

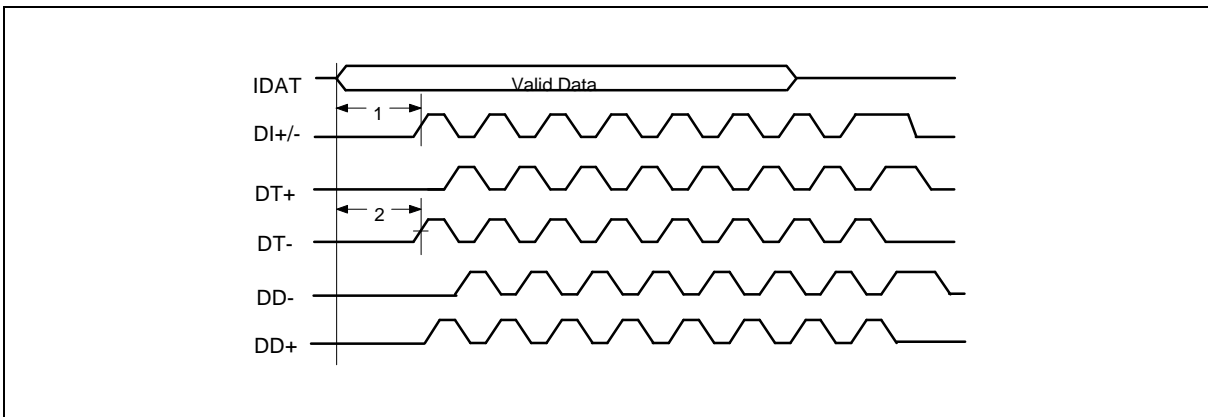

Figure 8

## Output Driver Timing

NO.	DESCRIPTION	FIG.	MIN.	TYP.	MAX.	UNIT
1	DT+ to DD+ and DT- to DD- delay	9	47		53	nS

## Output Driver Timing Diagram

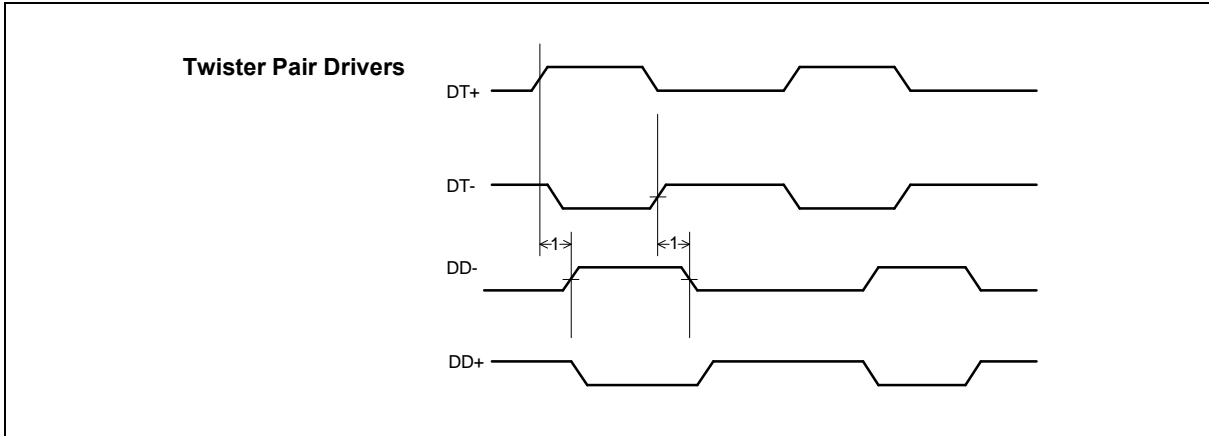

Figure 9

## Repetition Timing (part 1)

NO.	DESCRIPTION	FIG.	MIN.	TYP.	MAX.	UNIT
1	Minimum AUI Start of Idle (SOI) Pulse Width	10	200			nS
2	Start of Idle Generated on Twisted Pair	10	250	300	350	nS
3	AUI to TP Propagation Delay	10		6		Bits
4	AUI to Inter-IMPR II interface Propagation Delay	10		5		Bits

## Repetition Timing Diagram (part 1)

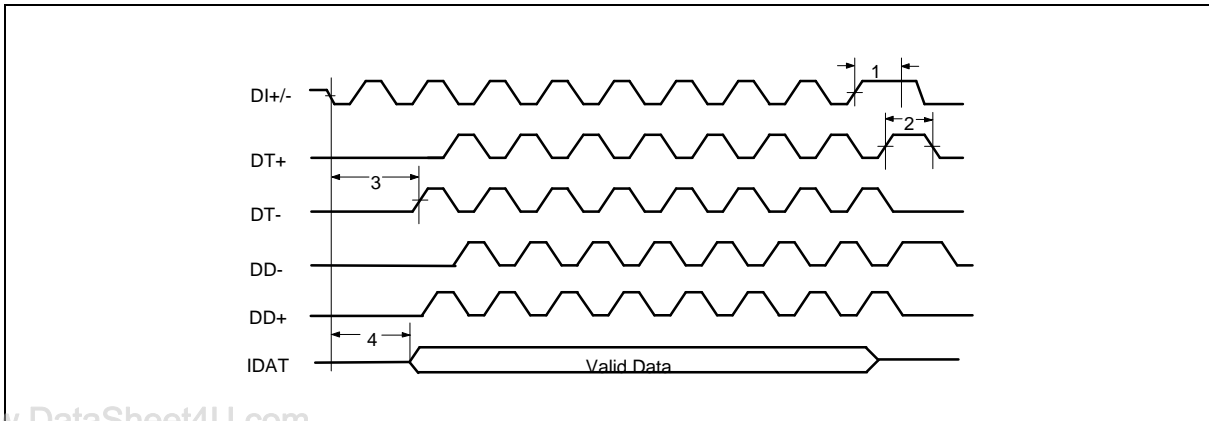

Figure 10

## Repetition Timing (part 2)

NO.	DESCRIPTION	FIG.	MIN.	TYP.	MAX	UNIT
1	Minimum Twisted Pair (SOI) Pulse Width	11	200			nS
2	TP to AUI Propagation Delay	11		7		Bits
3	TP to TP Propagation Delay	11		7		Bits
4	TP to Inter-IMPR II Interface Propagation Delay	11		6		Bits

## Repetition Timing Diagram (part 2)

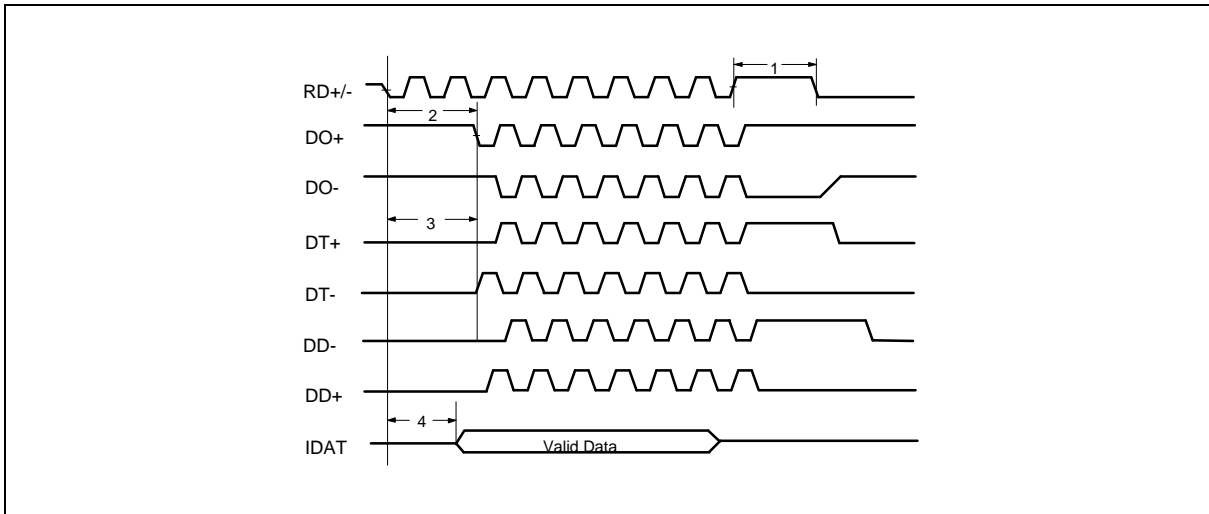

Figure 11

## Link Test Timing

NO.	DESCRIPTION	FIG.	MIN.	TYP.	MAX.	UNIT
1	DT+ link pulse width	12		100		nS
2	Duration between transmitted link pulses	12		16	64	mS
3	Duration between received link pulses	12	3.8		64	mS

## Link Test Timing Diagram

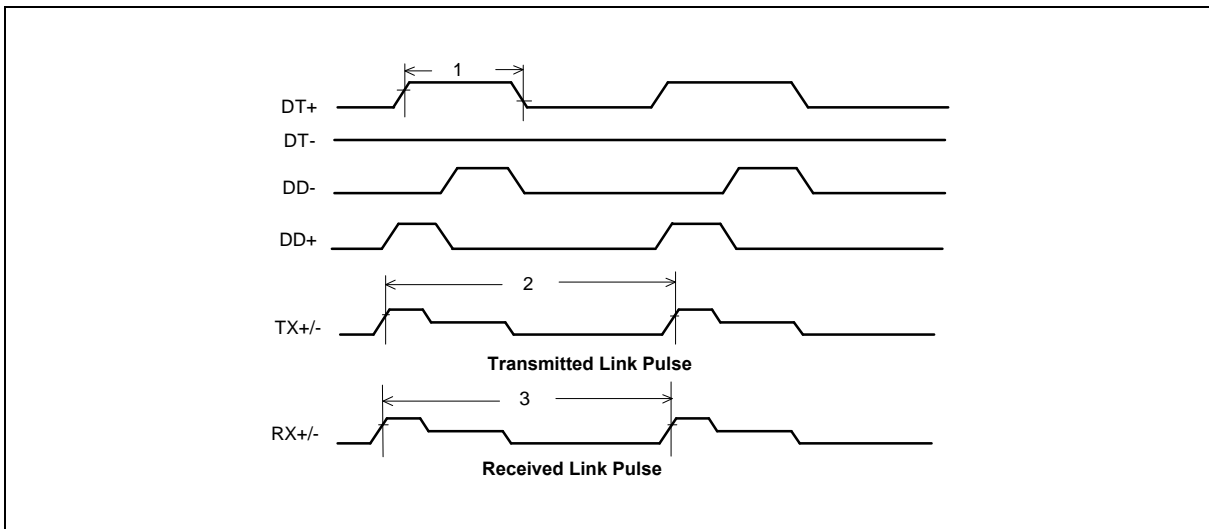
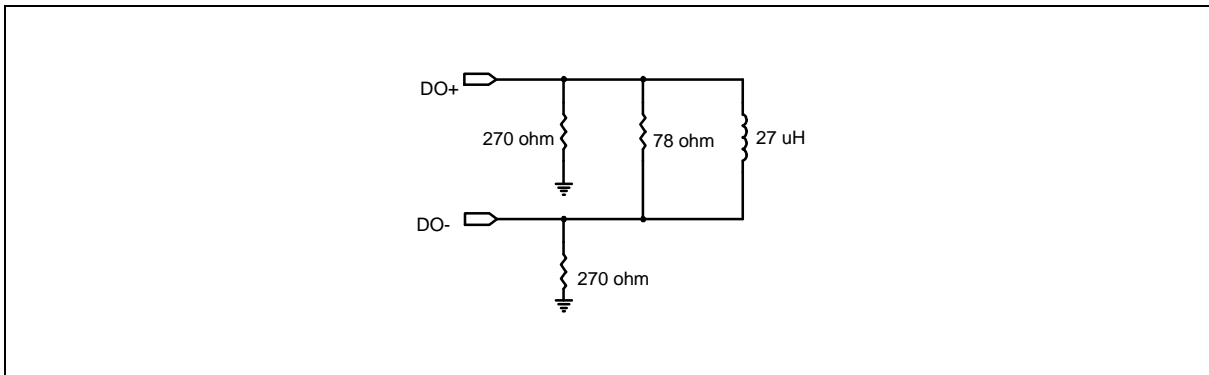

Figure 12

## AUI and DO+/- Switch Test Load



# Preliminary W89C982AF



## Digital Output Switching Test Load

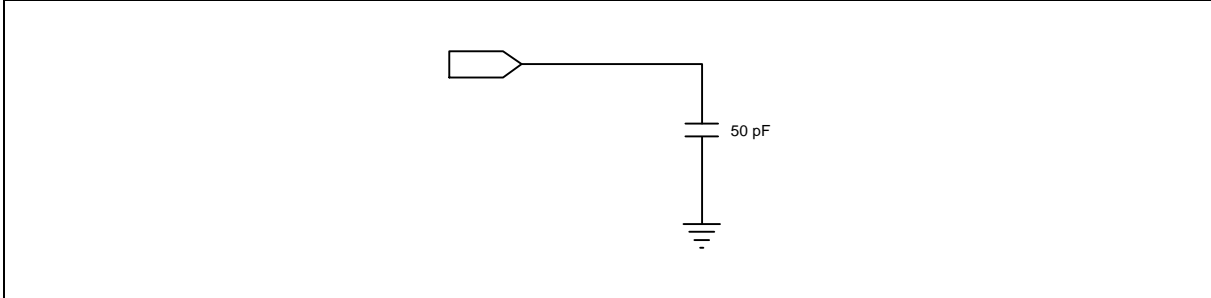

## Pre-equalization Network

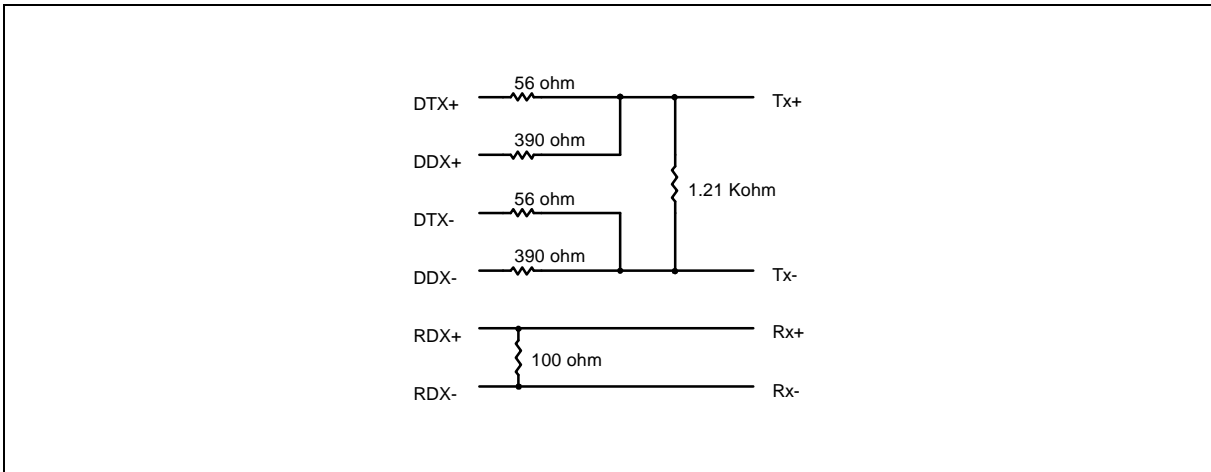

# Preliminary W89C982AF



## PACKAGE DIMENSIONS

### 100-pin QFP

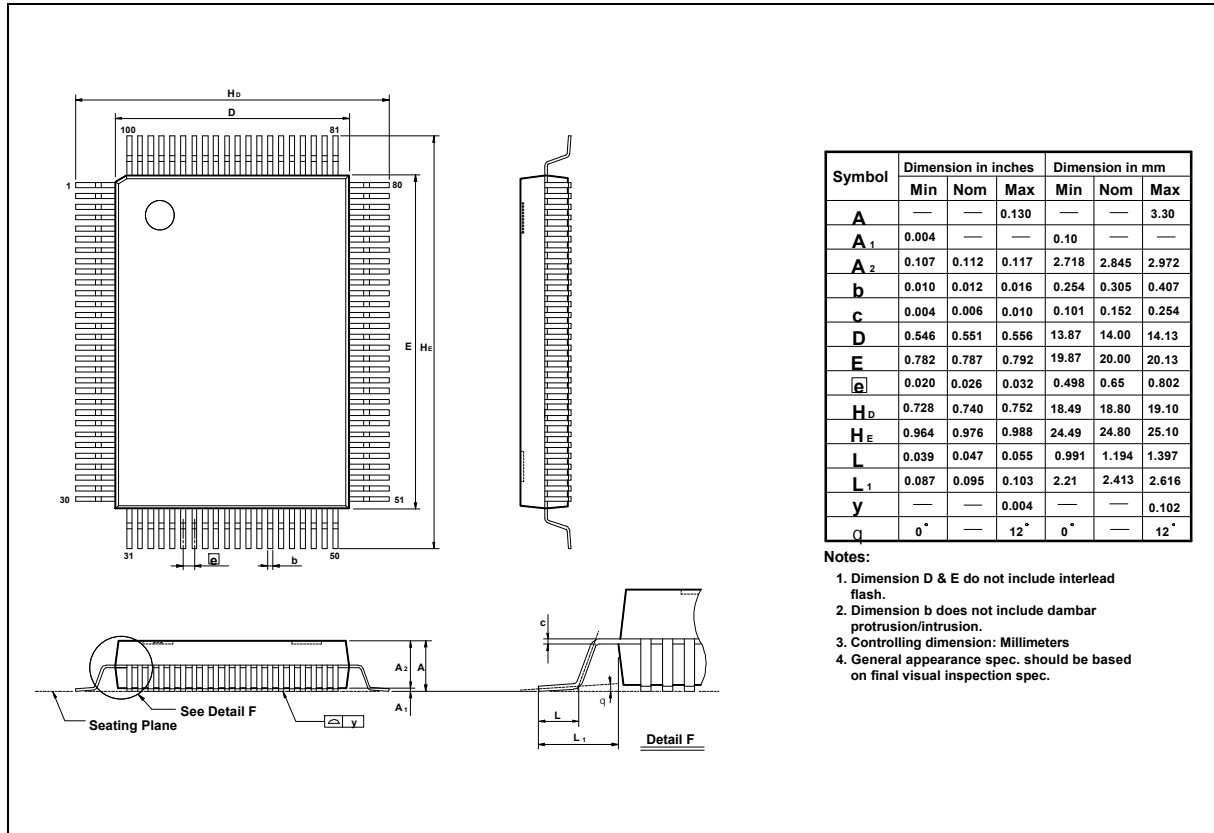

#### Headquarters

No. 4, Creation Rd. III,  
Science-Based Industrial Park,  
Hsinchu, Taiwan  
TEL: 886-3-5770066  
FAX: 886-3-5792646  
<http://www.winbond.com.tw/>  
Voice & Fax-on-demand: 886-2-7197006

#### Taipei Office

11F, No. 115, Sec. 3, Min-Sheng East Rd.,  
Taipei, Taiwan  
TEL: 886-2-7190505  
FAX: 886-2-7197502

#### Winbond Electronics (H.K.) Ltd.

Rm. 803, World Trade Square, Tower II,  
123 Hoi Bun Rd., Kwun Tong,  
Kowloon, Hong Kong  
TEL: 852-27513100  
FAX: 852-27552064

#### Winbond Electronics North America Corp.

Winbond Memory Lab.  
Winbond Microelectronics Corp.  
Winbond Systems Lab.

2727 N. First Street, San Jose,  
CA 95134, U.S.A.  
TEL: 1-408-9436666  
FAX: 1-408-5441798

Note: All data and specifications are subject to change without notice.