



LA7411,7411M

Playback Amplifier and Record Amplifier for VHS VCRs

Overview

The LA7411 and LA7411M are playback and record amplifier IC for two-head VHS VCRs. When used in conjunction with the video signal processing ICs of the LA7420/30 series, it is possible to eliminate the need to adjust the Y/C record current.

Functions

- 2-channel playback amplifier.
- 1-channel record amplifier.
- REC/PB mode switching head switch circuit.
- Envelope wave detection (for auto-tracking).

Features

- The record amplifier provides stable record characteristics in constant current drive mode, which is able to withstand load fluctuations. In addition, the built-in AGC eliminates the need to adjust the record current.
- Designed to share printed circuit boards with the LA7416/7416M (for 4-head systems).

Package Dimensions

unit : mm

3067-DIP24S

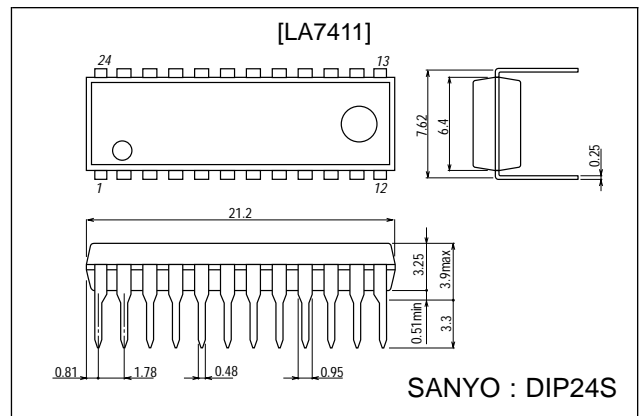

3112-MFP24S

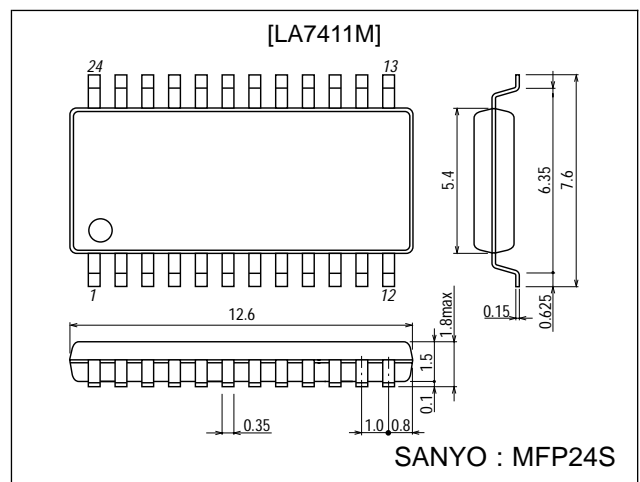

■ Any and all SANYO products described or contained herein do not have specifications that can handle applications that require extremely high levels of reliability, such as life-support systems, aircraft's control systems, or other applications whose failure can be reasonably expected to result in serious physical and/or material damage. Consult with your SANYO representative nearest you before using any SANYO products described or contained herein in such applications.

■ SANYO assumes no responsibility for equipment failures that result from using products at values that exceed, even momentarily, rated values (such as maximum ratings, operating condition ranges, or other parameters) listed in products specifications of any and all SANYO products described or contained herein.

Specifications

Maximum Ratings at Ta = 25 °C

Parameter	Symbol	Conditions	Ratings	Unit
Maximum supply voltage	V _{CC} max		7.0	V
Allowable power dissipation	Pd max	Ta ≤ 65 °C	700	mW
			*500	mW
Operating temperature	T _{opr}		-10 to +65	°C
Storage temperature	T _{stg}		-40 to +150	°C

*: LA7411M Pd max value which represents the value when mounted on the board.

Operating Conditions at Ta = 25 °C

Parameter	Symbol	Conditions	Ratings	Unit
Recommended supply voltage	V _{CC}		5.0	V
Operating supply voltage range	V _{CC} op		4.8 to 5.5	V

Electrical Characteristics at Ta = 25 °C

Parameter	Symbol	Input	Output	Conditions	T1	T2	min	typ	max	Unit	
[PB Mode]				T12: 5.0 V T10: Open T4: Open (PB)	EP/SP	SW30 MUTE					
Current consumption	I _{CCP}			Pin 12 input current		0	14	18	22	mA	
Voltage gain L	CH1	G _{VP1}	T17A	T7A	V _I = 38 mVp-p f = 1 MHz	0	56.5	59.5	62.5	dB	
Voltage gain H	CH2	G _{VP2}	T20A	T7A		2.5	56.5	59.5	62.5	dB	
Voltage gain difference		ΔG _{VP1}			G _{VP1} — G _{VP2}		-1	0	+1	dB	
Equivalent input noise voltage	CH1	V _{NIN1}	T17A	T7A	After 1.1 MHz LPF V _{OUT} /G _{VP1,2}	0		1.1	1.5	μVrms	
	CH2	V _{NIN2}	T20A	T7A		2.5		1.1	1.5	μVrms	
Frequency characteristics	CH1	ΔV _{fp1}	T17A	T7A	V _I = 38 mVp-p, f = 7 MHz V _{OUT} /G _{VP1,2} output ratio	0	-2.5	+1		dB	
	CH2	ΔV _{fp2}	T20A	T7A		2.5	-2.5	+1		dB	
Secondary harmonic distortion	CH1	V _{HDP1}	T17A	T7A	V _I = 38 mVp-p, f = 4 MHz 8 M component 4 M component output ratio	0		-40	-35	dB	
	CH2	V _{HDP2}	T20A	T7A		2.5		-40	-35	dB	
Maximum output level	CH1	V _{OMP1}	T17A	T7A	f = 1 MHz Output level when tertiary distortion of the output is -30 dB	0	1.0	1.2		Vp-p	
	CH2	V _{OMP2}	T20A	T7A		2.5	1.0	1.2		Vp-p	
Cross-talk (Note 1)	CH1	V _{CR1}	T20A	T7A	V _I = 38 mVp-p, f = 4 MHz V _{OUT} /G _{VP1,2} output ratio	0		-40	-35	dB	
	CH2	V _{CR2}	T17A	T7A		2.5		-40	-35	dB	
Output DC offset		ΔV _{ODC1}		T7	CH1-CH2	0	-100	0	+100	mV	
			2.5								
Envelope wave detection output pin voltage		V _{ENV}		T5	T5 DC voltage with no input	0	0	0	0.8	1.5	V
Envelope wave detection voltage SP1		V _{ENVSP1}	T17A	T5	f = 4 MHz, T7A: Adjusted to 175 mVp-p	0	0	2.0	2.5	3.0	V
Envelope wave detection voltage SP2		V _{ENVSP2}	T17A	T5	f = 4 MHz, T7A: Adjusted to 450 mVp-p	0	0	4.5	4.8	5.0	V
Envelope wave detection voltage EP1		V _{ENVEP1}	T17A	T5	f = 4 MHz, T7A: Adjusted to 125 mVp-p	5.0	0	2.0	2.5	3.0	V

Note 1: Status where input stage L (8.2 μH) is shorted
“***” represents output pins.

LA7411,7411M

Electrical Characteristics at Ta = 25 °C

Parameter	Symbol	Input	Output	Conditions	T10	T2	min	typ	max	Unit
Envelope wave detection voltage EP2	V _{ENVEP2}	T17A	T5	f = 4 MHz, T7A: Adjusted to 350 mVp-p	5.0	0	4.5	4.8	5.0	V
ON resistance of SW-Tr which is turned ON in PB mode	R _{PON14}		P-14	DC difference measured for 1 mA, 2 mA current inflow				4.0	6.0	Ω
Threshold level EP/SP	EPS-1		T1	SP → EP	*		1.7		5.0	V
	EPS-2		T1	EP → SP	*		0.0		1.3	V
Threshold level SW30	SW30-1		T2	Lch → Hch		*	1.2		5.0	V
	SW30-2		T2	Hch → Lch		*	0.0		0.8	V
[REC Mode]				T12: 5.0 V T3: 5.0 V T4: 5.0 V(REC)	REC Adj2	SW30 MUTE				
Current consumption	I _{CCP}			Pin 12 input current	Open	0	38	46	54	mA
REC AGC Amp output level	V _R	T8A	T18A	f = 4 MHz V _I = 200 mVp-p	Open	0	116	123	130	mVp-p
AGC Amp control characteristics 1	ΔV _{AGC1}	T8A	T18A	f = 4 MHz, V _I = 400 mVp-p Output level/ V _{RSP, EP} ratio	Open	0		0.5	1.0	dB
AGC Amp control characteristics 2	ΔV _{AGC2}	T8A	T18A	f = 4 MHz, V _I = 100 mVp-p Output level/ V _{RSP, EP} ratio	Open	0	-1.0	-0.5		dB
AGC Amp frequency characteristics (Note 2)	ΔV _{FR}	T8A	T18A	f = 1 M, 7 MHz V _I = 200 mVp-p 7 MHz/1 MHz, output ratio	Open	0	-4.0	-3.0	-2.0	dB
AGC Amp secondary harmonic level	ΔV _{HDR}	T8A	T18A	f = 4 MHz, V _I = 200 mVp-p 8 M component 4 M component output ratio	Open	0		-45	-40	dB
AGC Amp maximum output level (Note 3)	ΔV _{OMR}	T8A	T18A	f = 4 MHz, output level when secondary distortion of the output is -35 dB	Adj.	0	20	22		mAp-p
AGC Amp mute attenuation	ΔV _{MR}	T8A	T18A	f = 4 MHz, V _I = 200 mVp-p Output level/ V _{RSP, EP} ratio	Open	5.0		-45	-40	dB
REC AGC Amp mixed modulation relative level	ΔV _{CY}	T7A	T18A	T6A: f = 629 kHz, V _I = 360 mVp-p T7A: f = 4 MHz, V _I = 200 mVp-p (4 M±629 k)/4 M output ratio	Open	0		-45	-40	dB
		T8A	T18A		Open	0		-45	-40	dB
ON resistance of SW-Tr which is turned ON in REC mode	R _{RON17}		P-17	DC difference measured for 1 mA, 2 mA current inflow				4.0	6.0	Ω
	R _{RON20}		P-20					4.0	6.0	Ω
REC MUTE threshold level	MUTE-1		T2	MUTE OFF → ON		*	3.4		5.0	V
	MUTE-2		T2	MUTE ON → OFF		*	0.0		3.0	V
REC/PB threshold level	SW REC/PB			T4: Control voltage			2.2		5.0	V

Note 2: Apply approximately 1.8 V DC to the AGC wave detection filter pin (pin 9) and fix the amplifier gain for measurement.

Note 3: Apply DC voltage to T10 (REC CUR. ADJ2) and adjust the output level.

Note : Use a resistor with a tolerance of ± 1.0% between pins 11 and 12.

“*” represents output pins.

LA7411,7411M

Test Circuit Diagram

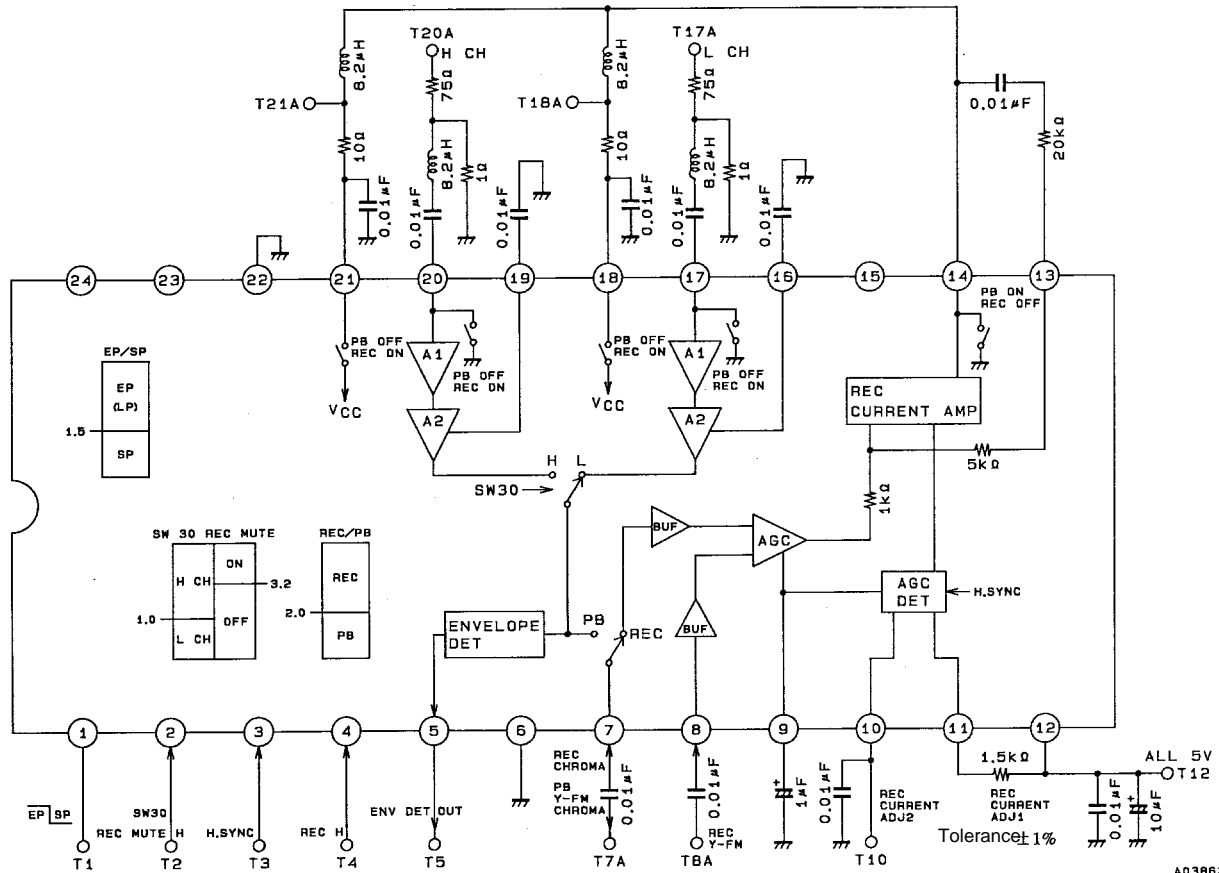

Sample Application Circuit

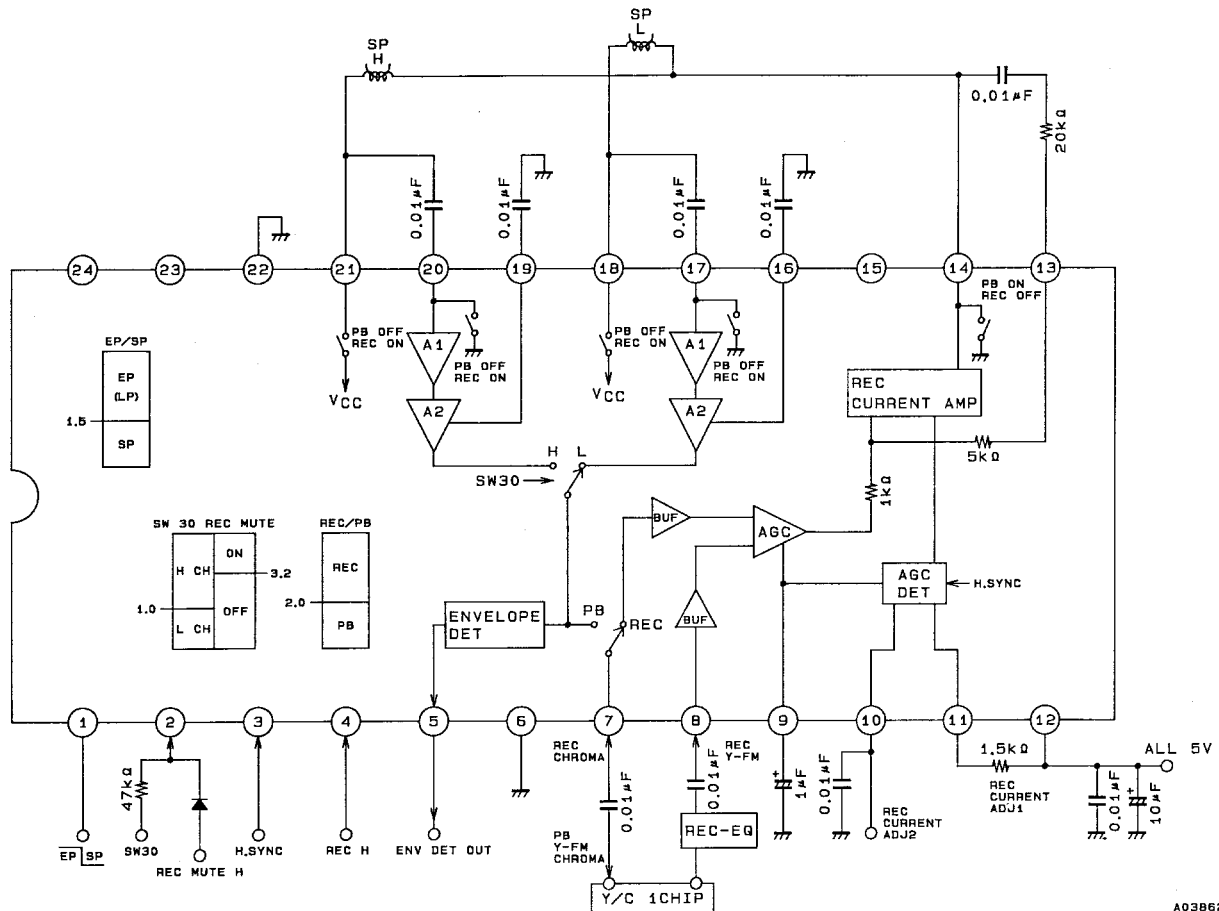

- Specifications of any and all SANYO products described or contained herein stipulate the performance, characteristics, and functions of the described products in the independent state, and are not guarantees of the performance, characteristics, and functions of the described products as mounted in the customer's products or equipment. To verify symptoms and states that cannot be evaluated in an independent device, the customer should always evaluate and test devices mounted in the customer's products or equipment.
- SANYO Electric Co., Ltd. strives to supply high-quality high-reliability products. However, any and all semiconductor products fail with some probability. It is possible that these probabilistic failures could give rise to accidents or events that could endanger human lives, that could give rise to smoke or fire, or that could cause damage to other property. When designing equipment, adopt safety measures so that these kinds of accidents or events cannot occur. Such measures include but are not limited to protective circuits and error prevention circuits for safe design, redundant design, and structural design.
- In the event that any or all SANYO products(including technical data, services) described or contained herein are controlled under any of applicable local export control laws and regulations, such products must not be exported without obtaining the export license from the authorities concerned in accordance with the above law.
- No part of this publication may be reproduced or transmitted in any form or by any means, electronic or mechanical, including photocopying and recording, or any information storage or retrieval system, or otherwise, without the prior written permission of SANYO Electric Co., Ltd.
- Any and all information described or contained herein are subject to change without notice due to product/technology improvement, etc. When designing equipment, refer to the "Delivery Specification" for the SANYO product that you intend to use.
- Information (including circuit diagrams and circuit parameters) herein is for example only ; it is not guaranteed for volume production. SANYO believes information herein is accurate and reliable, but no guarantees are made or implied regarding its use or any infringements of intellectual property rights or other rights of third parties.

This catalog provides information as of June, 1995. Specifications and information herein are subject to change without notice.