

DESCRIPTION

These low capacitance diode arrays are multiple, discrete, isolated junctions fabricated by a planar process and mounted in a 14-pin package for use as steering diodes protecting up to eight I/O ports from positive ESD, EFT, or surge by directing them to the positive side of the power supply (pin 14). An external TVS diode may be added between the positive supply line and ground to prevent overvoltage on the supply rail. They may also be used in fast switching core-driver applications. This includes computers and peripheral equipment such as magnetic cores, thin-film memories, plated-wire memories, etc., as well as decoding or encoding applications. These arrays offer many advantages of integrated circuits such as high-density packaging and improved reliability. This is a result of fewer pick and place operations, smaller footprint, smaller weight, and elimination of various discrete packages that may not be as user friendly in PC board mounting. They are available with either Tin-Lead plating terminations or as RoHS Compliant with annealed matte-Tin finish by adding an "e3" suffix to the part number.

*See MMAD1106(e3) for directing negative transients to ground.

IMPORTANT: For the most current data, consult MICROSEMI's website: <http://www.microsemi.com>

APPEARANCE

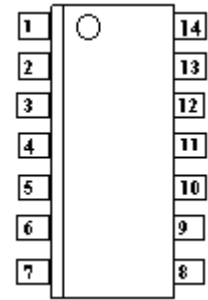
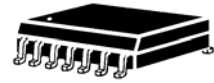

Top Viewing Pin Layout

FEATURES

- 8 Diode Array
- Molded 14-Pin SOIC Package
- UL 94V-0 Flammability Classification
- Low Capacitance 1.5 pF per diode
- Switching speeds less than 5 ns
- RoHS Compliant devices available by adding "e3" suffix
- IEC 61000-4 compatible
 - 61000-4-2 (ESD): Air 15kV, contact – 8 kV
 - 61000-4-4 (EFT): 40A – 5/50 ns
 - 61000-4-5 (surge): 12A, 8/20 μ s

MAXIMUM RATINGS

- Operating Temperature: -55°C to +150°C
- Storage Temperature: -55°C to +150°C
- Forward Surge Current: 2 Amps (8.3 ms)
12 Amps (8/20 μ s)
- Continuous Forward Current: 400 mA (one diode)
- Power Dissipation (P_D): 1500 mW (total)
- Solder Temperatures: 260°C for 10 s (maximum)

APPLICATIONS / BENEFITS

- Low capacitance steering diode protection for high frequency data lines
- RS-232 & RS-422 Interface Networks
- Ethernet: 10 Base T
- Computer I / O Ports
- LAN
- Switching Core Drivers

MECHANICAL AND PACKAGING

- CASE: Void-free transfer molded thermosetting epoxy body meeting UL94V-0 flammability classification
- TERMINALS: Tin-Lead or RoHS Compliant annealed matte-Tin plating solderable per MIL-STD-750 method 2026
- MARKING: MSC logo, MMAD1105 or MMAD1105e3 and date code. Pin #1 is to the left of the dot or indent on top of package
- WEIGHT: 0.127 grams (approximate)
- Tape & Reel packaging: 2500 pcs (STANDARD)
- Carrier tube packaging: 55 pcs

ELECTRICAL CHARACTERISTICS PER LINE @ 25°C Unless otherwise specified

PART NUMBER	BREAKDOWN VOLTAGE V_{BR} @ $I_{BR}=100\mu A$	WORKING PEAK REVERSE VOLTAGE V_{RWM}	LEAKAGE CURRENT I_R $T_A = 25^\circ C$		LEAKAGE CURRENT I_R $T_A = 150^\circ C$		CAPACITANCE C @ 0 V	REVERSE RECOVERY TIME t_{rr}	FORWARD VOLTAGE V_F $I_F = 10 mA$	FORWARD VOLTAGE V_F $I_F = 100 mA$
	V	V	MAX	@ V_R	MAX	@ V_R	pF	ns	V	V
MMAD1105 MMAD1105e3	MIN	MAX	MAX		MAX		TYP	MAX	MAX	MAX
	90	75	0.200	20	300	20	1.5	5.0	1.00	1.20

SYMBOLS & DEFINITIONS

Symbol	Definition
V_{BR}	Minimum Breakdown Voltage: The minimum voltage the device will exhibit at a specified current.
V_{RWM}	Working Peak Reverse Voltage: The maximum peak voltage that can be applied over the operating temperature range.
V_F	Maximum Forward Voltage: The maximum forward voltage the device will exhibit at a specified current.
I_R	Maximum Leakage Current: The maximum leakage current that will flow at the specified voltage and temperature.
C	Capacitance: The capacitance of the TVS as defined @ 0 volts at a frequency of 1 MHz and stated in picofarads.

OUTLINE AND CIRCUIT

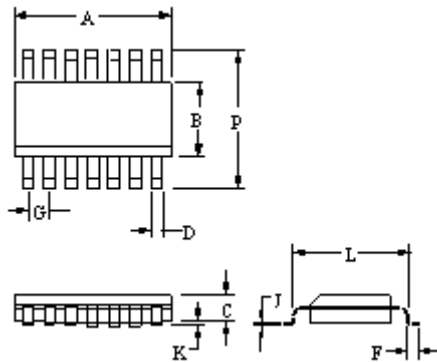

DIM	INCHES		MILLIMETERS	
	MIN	MAX	MIN	MAX
A	0.336	0.344	8.53	8.74
B	0.150	0.158	3.81	4.01
C	0.053	0.069	1.35	1.75
D	0.011	0.021	0.28	0.53
F	0.016	0.050	0.41	1.27
G	0.050 BSC		0.127 BSC	
J	0.006	0.010	0.15	0.25
K	0.004	0.008	0.10	0.20
L	0.189	0.206	4.80	5.23
P	0.228	0.244	5.79	6.19

OUTLINE

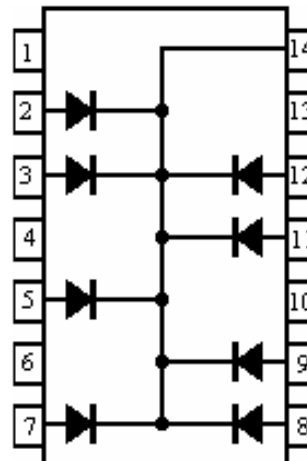

CIRCUIT CONFIGURATION

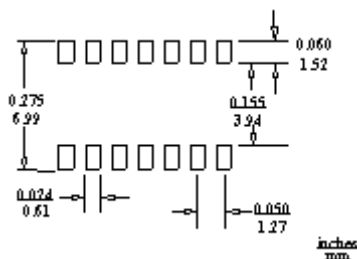

PAD LAYOUT