

PRODUCT DESCRIPTION

The IMI145151 is a member of a family of phaselock loop synthesizer ICs from International Microcircuits. The IMI145151 is an improved version of the Motorola MC145151 and will provide a synthesizer with noticeably improved performance.

The IMI145151 is programmed with parallel input data lines. Since it does not require a microcontroller as serial and bus programmed units do, the IMI145151 is an excellent choice for synthesizers requiring independence from digital controllers. Such applications include fixed local oscillator signals, whose tuning never changes, and signal sources, which have few operating frequencies.

Blocks in the IMI145151 include a programmable feedback divider, a reference divider, phase detector, and charge pump. The reference divider is programmed by three select lines to one of eight ROM encoded values. Both counter inputs are biased for maximum sensitivity to sinewave input signals. The reference divider input is also configured to operate as a crystal oscillator if desired.

The IMI145151 has a Type IV phase frequency detector which has eliminated by the design the inherent dead zone which causes crossover distortion at the critical center lock point. The IMI circuitry enables consistent low noise loop designs using the simple single ended charge pump output. Differential charge pump outputs are also provided for those who require a more sophisticated differential active loop filter design.

Performance improvements are in the operating bandwidth and phase detector noise floor. With its extremely low phase noise floor and wider input bandwidth, prescaler ratios can be minimized to allow wide loop bandwidths for faster settling and lower phase noise.

PRODUCT FEATURES

- >200 Mhz typical input frequency.
- -163 dBc/Hz total phase noise floor.
- No dead zone, by design.
- Unambiguous PLL acquisition.
- 8 user-selectable reference divider ratios: 8, 128, 256, 512, 1024, 2048, 2410, 8192.
- Lock detect signal.
- 14 bit N counter. Divider range = 3 to 16383.
- On- or off-chip reference oscillator operation.
- 3-volt and 5-volt characterizations.

BLOCK DIAGRAM

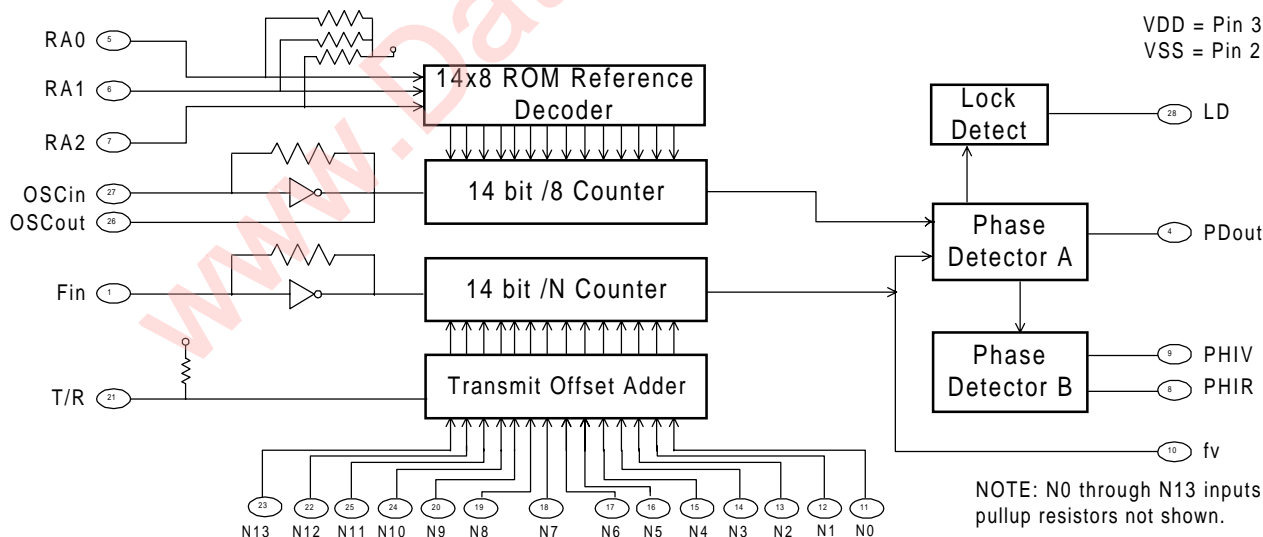

PIN DESCRIPTIONS																																					
Pin No.	Name	Description																																			
1	Fin	RF input signal. Applied to both the N and A counters. This signal is intended to be AC coupled for low level sinewave input signals. For CMOS logic level input signals, DC coupling can be used.																																			
2	Vss	Circuit ground.																																			
3	Vdd	Circuit-positive power supply.																																			
4	Pdout	Single-ended charge pump output, usually used with passive loop filters. This signal operates according to the following: <ul style="list-style-type: none"> ■ Frequency $f_v > f_r$ at the phase detector: negative pulses. ■ Frequency $f_v < f_r$ at the phase detector: positive pulses. ■ Frequency $f_v = f_r$ at the phase detector: high-impedance state. 																																			
5	RA0	The three reference divisor ratio select pins. Pull-up resistors are included on each of these pins to insure that, if left unconnected, they will remain at a logic ONE. The reference divider ratio is set according to the following table:																																			
6	RA1																																				
7	RA2																																				
			RA2	RA1	RA0	Reference Divider Ratio	0	0	0	8	0	0	1	128	0	1	0	256	0	1	1	512	1	0	0	1024	1	0	1	2048	1	1	0	2410	1	1	1
RA2	RA1	RA0	Reference Divider Ratio																																		
0	0	0	8																																		
0	0	1	128																																		
0	1	0	256																																		
0	1	1	512																																		
1	0	0	1024																																		
1	0	1	2048																																		
1	1	0	2410																																		
1	1	1	8192																																		
8	PHIR	Phase detector output. This signal goes LOW when the feedback frequency is too low.																																			
9	PHIV	Phase detector output. This signal goes LOW when the feedback frequency is too high.																																			
10	fv	Output of the feedback divider.																																			
11	N0	LSB of the N counter programming input bits. Pull-up resistor included.																																			
12	N1	LSB+1 of the N counter programming input bits. Pull-up resistor included.																																			
13	N2	LSB+2 of the N counter programming input bits. Pull-up resistor included.																																			
14	N3	LSB+3 of the N counter programming input bits. Pull-up resistor included.																																			
15	N4	LSB+4 of the N counter programming input bits. Pull-up resistor included.																																			
16	N5	LSB+5 of the N counter programming input bits. Pull-up resistor included.																																			
17	N6	LSB+6 of the N counter programming input bits. Pull-up resistor included.																																			
18	N7	LSB+7 of the N counter programming input bits. Pull-up resistor included.																																			
19	N8	LSB+8 of the N counter programming input bits. Pull-up resistor included.																																			
20	N9	LSB+9 of the N counter programming input bits. Pull-up resistor included.																																			
21	T/R	This input control an offset that can be added to the programming inputs. This offset is fixed at 856 when T/R is low. When T/R is high, there is no offset added. A pull-up resistor is included.																																			
22	N12	LSB+12 of the N counter programming input bits. Pull-up resistor included.																																			
23	N13	LSB+13 of the N counter programming input bits. Pull-up resistor included.																																			
24	N10	LSB+10 of the N counter programming input bits. Pull-up resistor included.																																			
25	N11	LSB+11 of the N counter programming input bits. Pull-up resistor included.																																			
26	OSCout	Reference signal output or output of the oscillator inverter.																																			
27	OSCin	AC-coupled reference signal input or input to the oscillator inverter.																																			
28	LD	Lock detect output. When the PLL is locked, this signal will be essentially HIGH, with very narrow negative spikes at the phase detection frequency. If the PLL is out of lock, this signal will pulse LOW.																																			

MAXIMUM RATINGS

Voltage Relative to VSS:	-0.3V to 7V
Voltage Relative to VDD:	0.3V
Storage Temperature:	-65°C to 150°C
Ambient Temperature:	-55°C to 125°C

This device contains circuitry to protect the inputs against damage due to high static voltages or electric field; however, precautions should be taken to avoid application of any voltage higher than the maximum rated voltages to this circuit. For proper operation, Vin and Vout should be constrained to the range:

$$V_{SS} < (V_{in} \text{ or } V_{out}) < V_{DD}$$

Unused inputs must always be tied to an appropriate logic voltage level (either Vss or VDD).

PLL OPERATING CHARACTERISTICS

VDD = 5 VOLTS

Characteristic		Symbol		-40°C		0°C		25°C			70°C		85°C		Unit	Conditions		
				Min	Max	Min	Max	Min	Typ	Max	Min	Max	Min	Max				
Dynamic	Operating Frequency	Fin	Sin	210	-	200	-	200	250	-	180	-	180	-	MHz			
			Square	210	-	200	-	200	250	-	180	-	180	-	MHz			
		Fosc												MHz				
	Synthesizer Phase Noise Floor	PDNF						-160							dBc/Hz			
	Pin Capacitance	Cin		-	10				-	6	10				-	10	pF	
		Cout		-	10				-	6	10				-	10	pF	
Static	Input Voltages	VIL		1	1.5	-	1.5	-	2.75	1.5	-	1.5	-	1.5		Vdc		
		VIH		3.5	-	3.5	-	3.5	2.75	-	3.5	-	3.5	-	3.5		Vdc	
	Output Voltages	VOL		-	0.05	-	0.05	-	0.0	0.05	-	.05	-	0.05		Vdc		
		VOH		4.95	-	4.95	-	4.95	5.0	-	4.95	-	4.95	-	4.95		Vdc	
	Output Current	IOH	Logic		2.4	-			2.0	2.8	-			1.6	-		mA	VOL = 0.40
			OSCOH		1.2	-			1.0	1.4	-			0.8	-		mA	VOH = 4.0
			Logic		-2.4	-			-2.0	-2.8	-			-1.6	-		mA	VOH = 4.0
	Charge Pump Current	IPU	OSCOH		-1.2	-			-1.0	-1.4	-			-0.8	-		mA	VOH = 4.0
									12.4								mA	Vdd = 5.0V
	Supply Currents	IDD															mA	Fosc=Fin=10 MHz
ISB				-	150			-	40	150			-	150		uA	Fosc=Fin=0	
IPU									50							uA	VIL = 0	

PLL OPERATING CHARACTERISTICS

VDD = 3 VOLTS

Characteristic		Symbol		-40°C		0°C		25°C			70°C		85°C		Unit	Conditions	
				Min	Max	Min	Max	Min	Typ	Max	Min	Max	Min	Max			
Dynamic	Operating Frequency	Fin	Sin	160	-	140	-	130	150	-	120	-	110	-	MHz		
			Square	160	-	140	-	130	150	-	120	-	110	-	MHz		
		Fosc												MHz			
	Synthesizer Phase Noise Floor	PDNF						-155							dBc/Hz		
	Pin Capacitance	Pin	Cin	-	10			-	6	10			-	10	pF		
		Cout	-	10			-	6	10			-	10	pF			
Static	Input Voltages	VIL		-	0.9			-	1.35	0.9			-	0.9	Vdc		
		VIH		2.1	-			2.1	1.65	-			2.1	-	Vdc		
	Output Voltages	VOL		-	0.05	-	0.05	-	0.0	0.05	-	.05	-	0.05	Vdc		
		VOH		2.95	-	2.95	-	2.95	3.0	-	2.95	-	2.95	-	Vdc		
	Output Current	IOL	Logic		1.6	-			1.4	2.0	-			0.8	-	mA	VOL = 0.30
			OSCut		0.8	-			0.7	1.0	-			0.4	-	mA	
		IOH	Logic		-1.6	-			-1.4	-1.0	-			-0.8	-	mA	VOH = 2.4
			OSCut		-0.8	-			-0.7	-1.0	-			-0.4	-	mA	VOH = 2.4
	Charge Pump Current							5.0							mA	Vdd = 3.0V	
	Supply Currents	IDD														mA	Fosc=Fin=10 MHz
ISB				-	150			-	40	150			-	150	uA	Fosc=Fin=0	
IPU									30						uA	VIL = 0	

5 VDC Input Sensitivity vs. Temp

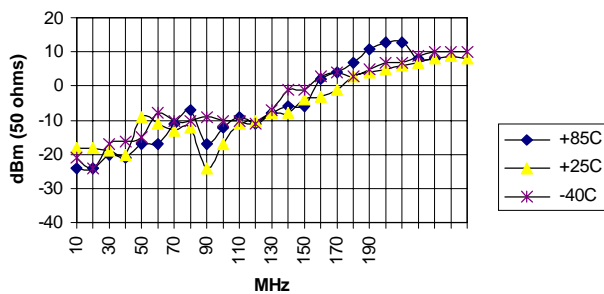

3 VDC Input Sensitivity vs. Temp

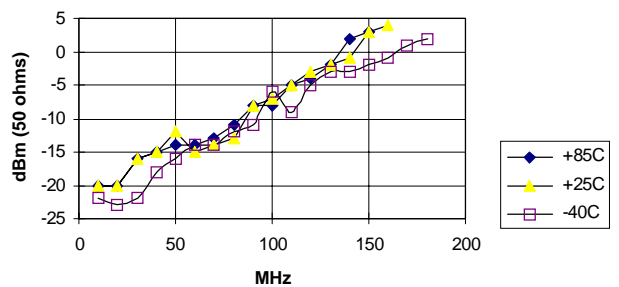

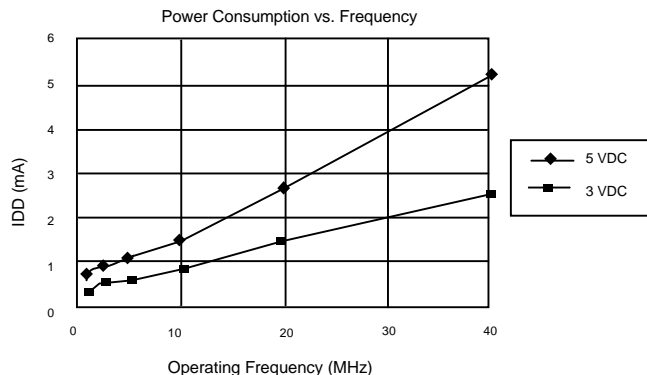
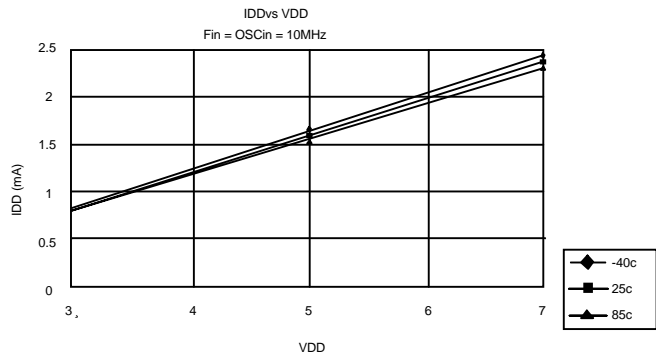

PHASE NOISE FLOOR

152/HP 10811A Ref vs 8662 Loop/Residual Noise @ 145 MHZ

(hp) 3018R Carrier: 145.E+6 Hz 8 Nov 1994 13:07:47 - 13:16:37

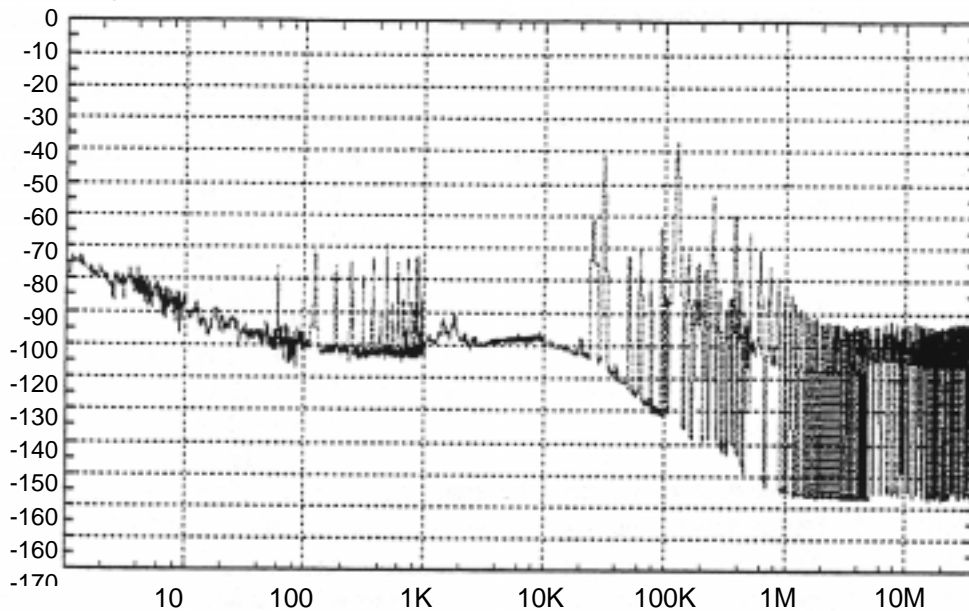

Fosc = 1 Mhz
Fref = 125 Khz
fin = 145 Mhz
N = 1160

Measured floor @ 500 Hz = -102 dBc/Hz
-20 log (N) = - 61 dB
- 163 dBc/Hz

CONNECTION DIAGRAMS

SSOP, SOIC AND PDIP PACKAGES

fin	<input type="checkbox"/>	1	28	<input type="checkbox"/>	LD
Vss	<input type="checkbox"/>	2	27	<input type="checkbox"/>	OSCin
VDD	<input type="checkbox"/>	3	26	<input type="checkbox"/>	OSCOut
Pdout	<input type="checkbox"/>	4	25	<input type="checkbox"/>	N11
RA0	<input type="checkbox"/>	5	24	<input type="checkbox"/>	N10
RA1	<input type="checkbox"/>	6	23	<input type="checkbox"/>	N13
RA2	<input type="checkbox"/>	7	22	<input type="checkbox"/>	N12
PHIR	<input type="checkbox"/>	8	21	<input type="checkbox"/>	T/R
PHIV	<input type="checkbox"/>	9	20	<input type="checkbox"/>	N9
fv	<input type="checkbox"/>	10	19	<input type="checkbox"/>	N8
N0	<input type="checkbox"/>	11	18	<input type="checkbox"/>	N7
N1	<input type="checkbox"/>	12	17	<input type="checkbox"/>	N6
N2	<input type="checkbox"/>	13	16	<input type="checkbox"/>	N5
N3	<input type="checkbox"/>	14	15	<input type="checkbox"/>	N4

PLCC PACKAGE

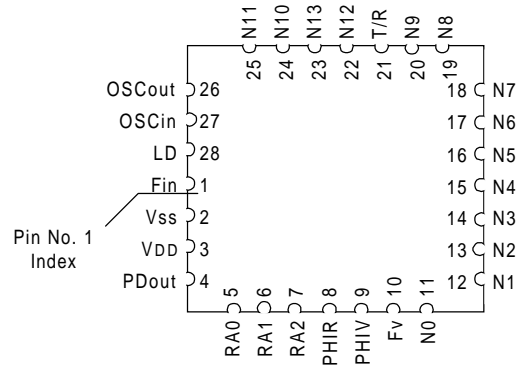

ORDERING INFORMATION		
Part Number	Package Type	Production Flow
IMI145151xPB	Plastic Dip	Commercial, 0°C to +70°C
IMI145151xB	SOIC	Commercial, 0°C to +70°C
IMI145151xB	SSOP	Commercial, 0°C to +70°C
IMI145151xB	PLCC	Commercial, 0°C to +70°C

*Please contact factory for other options.

NOTE: The "x" following the IMI Device Number denotes the device revision. The ordering part number is formed by a combination of device number, device revision, package style, and screening as shown below.

Marking: Example: IMI
145151xPB
Date Code, Lot #

IMI145151xPB

