

9347963 UNITRODE CORP

92D 10986 D

T-03-17

RECTIFIERS

High Efficiency, 16A

SES5501
SES5502
SES5503
SES5504

FEATURES

- Very Low Forward Voltage
- Very Fast Recovery Times
- Economical, Convenient TO-220 Package
- Low Thermal Resistance
- Mechanically Rugged

DESCRIPTION

The SES5500 Series, in the economical, convenient TO-220 package, is specifically designed for operation in power switching circuits to frequencies in excess of 100kHz. The very low forward voltage and very fast recovery time make them particularly suited for switching type power supplies.

ABSOLUTE MAXIMUM RATINGS

Peak Inverse Voltage, SES5501	50V
Peak Inverse Voltage, SES5502	100V
Peak Inverse Voltage, SES5503	150V
Peak Inverse Voltage, SES5504	200V
Maximum Average D.C. Output Current	

- @ T_C = 95°C 16A
- @ T_A = 25°C 3.3A
- @ T_A = 25°C (Note 1) 9.0A

Non-Repetitive Sinusoidal Surge Current, 8.3ms	250A
Thermal Resistance, Junction to Case, θ _{J-C}	1.5°C/W
Thermal Resistance, Junction to Ambient, θ _{J-A}	60°C/W
Operating and Storage Temperature	-55°C to +150°C

Note: 1. Using Wakefield Type 295 heatsink with convection cooling. For more definitive data refer to the Output Current vs Temperature Curve on this data sheet.

ELECTRICAL SPECIFICATIONS

Type	PIV	Maximum Forward Voltage		Maximum Reverse Current @ PIV		Maximum Reverse Recovery Time*	Typical Forward Recovery Voltage @ 1A t _r = 8ns
		T _J = 25°C	T _J = 100°C	T _J = 25°C	T _J = 100°C		
SES5501	50V	1.025V @ 16A	.945V @ 16A	10μA	800μA	100ns	2.0V
SES5502	100V						
SES5503	150V						
SES5504	200V						

* Measured in circuit I_F = 1/2A, I_R = 1.0A, I_{REC} = 1/4A

MECHANICAL SPECIFICATIONS

SEATING PLANE

SECT-A-A

G PIN 1. Cathode
PIN 2. Anode
Tab is connected to Cathode.

SES5501-SES5504

	INCHES		MILLIMETERS	
	MIN	MAX	MIN	MAX
A	0.560	0.625	14.23	15.87
B	0.380	0.420	9.66	10.66
C	0.140	0.190	3.56	4.82
D	0.020	0.045	0.51	1.14
F	0.139	0.147	3.531	3.733
G	0.090	0.110	2.29	2.79
H	—	0.250	—	6.35
J	0.015	0.025	0.38	0.64
K	0.500	0.562	12.70	14.27
L	0.045	0.070	1.14	1.77
N	0.190	0.210	4.83	5.33
Q	0.100	0.120	2.54	3.04
R	0.060	0.115	2.04	2.92
S	0.045	0.055	1.14	1.39
T	0.230	0.270	5.85	6.85

TO-220AC



9347963 UNITRODE CORP

92D 10987 D

SES5501 SES5502 SES5503 SES5504

T-03-17

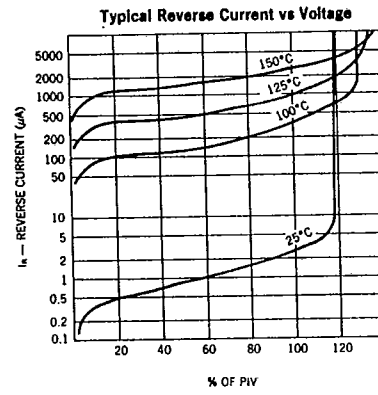
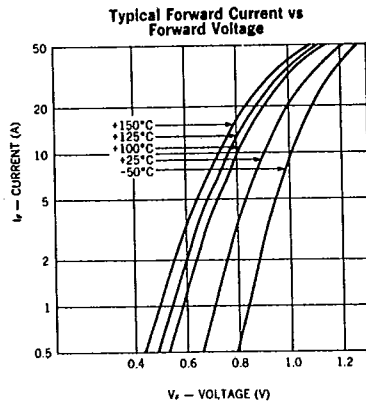
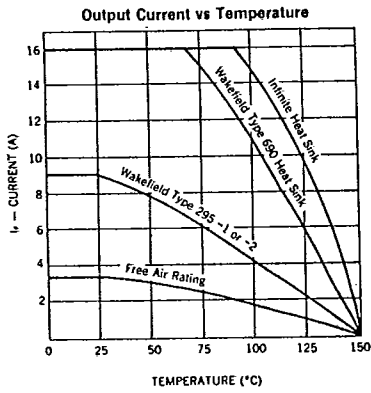

4

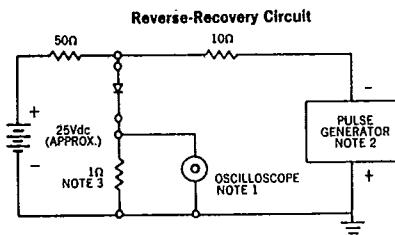
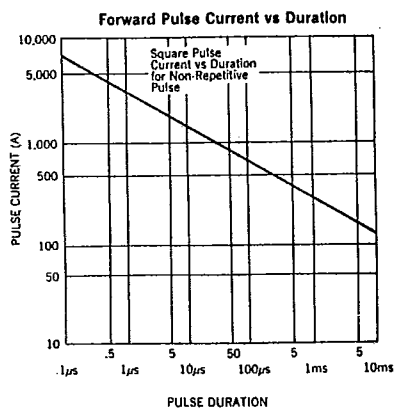
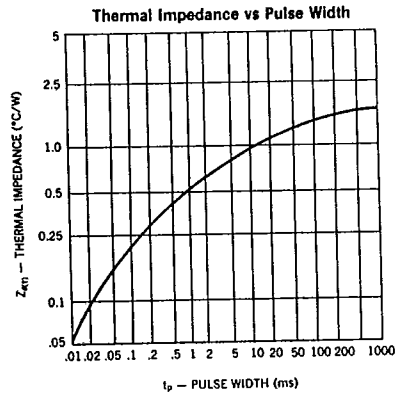
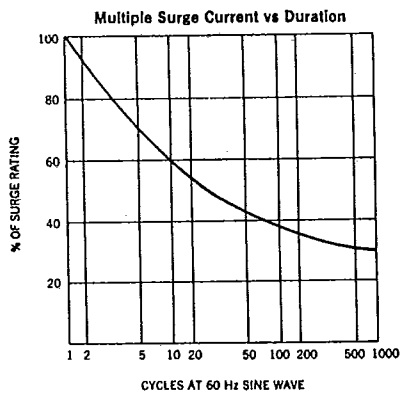

- NOTES:
1. Oscilloscope: Rise time ≤ 3ns; input impedance = 50Ω.
 2. Pulse Generator: Rise time ≤ 8ns; source impedance 10Ω.
 3. Current viewing resistor, non-inductive, coaxial recommended.

TO-220 PACKAGE MOUNTING AND THERMAL CONSIDERATIONS

TH-1

T-90-20

The leads of the TO-220 rectifiers and Schottky diodes may be formed, but they are not intended to be flexible or ductile enough for unrestrained lead wrapping.

The figures show the typical device and hardware recommended. Several typical configurations of lead forming are illustrated.

The advantages of mounting the flange to the printed circuit board is that improved thermal heat transfer allows operating at higher levels of power dissipation. The individual specification sheets give the safe operating area as a function of a case temperature.

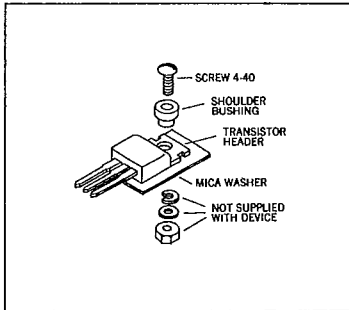

Figure A. Device and Hardware for Insulated Mounting.

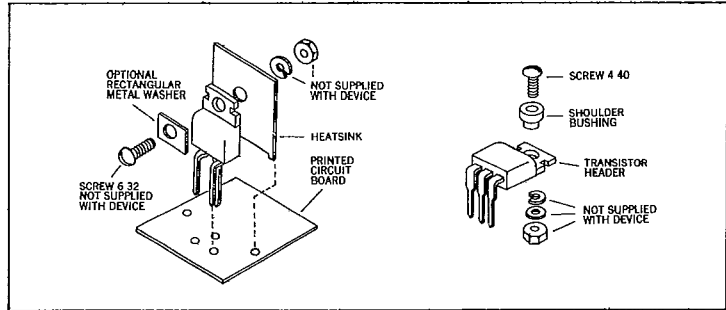

Figure B. Two Alternative Configurations for Axial Strain Relief and Electrical Isolation.

BENDING THE LEADS

Whenever the leads of the T-220 are to be formed, whether by a special fixture or by the use of long-nosed pliers, several important considerations must be followed. Internal damage to the device or lead damage may result if any or all of these precautions are not considered.

1. Minimum bend distance between the plastic body and the bend is $\frac{1}{16}$ inch.
2. The minimum radius of the bend is $\frac{1}{16}$ inch.
3. Avoid repeating bending at the same flexure point.
4. Whenever possible, use one of the lead forming configurations which relieve strain induced by mechanical or thermal loads.
5. Leads should not be bent greater than 90 degrees.
6. Avoid axial pulling or bending that would induce axial strain. The maximum axial component is 4 pounds.

7. Forming fixtures or pliers should not touch the plastic case because axial strain of $\approx .005$ " could cause irreversible internal damage.
8. The leads must be fully restrained during the lead forming operation to prevent relative movement between the body and the leads.

SOLDERING INTO THE CIRCUIT

The leads on the TO-220 are solderable; however, there are a few precautions that must be observed.

1. Soldering temperature must not exceed 270°C.
2. Maximum soldering temperature must not be applied for more than 5 seconds.
3. Maximum soldering temperature should not be applied closer than $\frac{1}{8}$ inch from the plastic body of the device.

TO-220 PACKAGE MOUNTING AND THERMAL CONSIDERATIONS

TH-1

T-90-20

MOUNTING THE FLANGE

Flange mounting is recommended for maximum power handling applications. A 6-32 machine screw is recommended. Eyeletting (hollow rivet) is acceptable if care is taken not to distort the flange. For insulated mount, a 4-40 screw and a shoulder bushing is recommended (see figure). Suggested material for bushings are: Diallphthalate, fiber-glass-filled nylon, or fiber-glass-filled polycarbonate. Note unfilled nylon should be avoided. The flange should not be directly soldered because the use of lead-tin could produce temperatures in excess of the maximum storage temperature. See the individual specification for the device.

Check list and summary for flange mounting:

1. Use recommended hardware.

2. Always fasten the flange prior to lead soldering.
3. Do not allow the forming tool to come in contact with the plastic body.
4. Maximum mounting torque is 8 inch-pounds.
5. Avoid modifying the flange by machining and do not use oversized screws.
6. Provide axial and transverse strain relief of the leads.
7. Use recommended insulation bushings. Avoid materials that exhibit hot-creep problems.

Thermal Considerations TO-220 Power Diodes

Thermal Resistance, Case to Ambient;
 Free Air, No Heatsink 60°C/W typical
 Thermal Capacitance
 of Package 4.8 watt-seconds/°C
 Thermal Time Constant 305 seconds

Device Type	I _F (AV)	Thermal Resistance Junction Case °C/W
UES1401-4	8	2.5
UES1501-4	16	1.5
USD635-50	6	3.0
USD835-50	12	2.4
USD935-50	16	2.0

Note: When using a 2 mil MICA washer for electrical isolation, add 0.4°C/W to heatsink thermal resistance.

12

Thermal joint compound should be used at the interface of the TO-220 flange and the heatsink to which it is attached.

Consider a TO-220 power rectifier with a thermal resistance junction to case of 1.5°C/W. The junction temperature produced depends upon the mounting conditions and power dissipated in the circuit. The table

shows junction temperature resulting from 15W of dissipation when mounted on an infinite heatsink at 100°C with different methods of interfacing.

Interface Condition Between Case and Heatsink	Thermal Resistance Case-Heatsink °C/W	Junction Temperature °C
Assumed direct, ideal metallic contact (no interference)	0.0	122
1 mil air gap*	1.2	140
Thermal compound; Tab screw torqued at 8 inch-pound	0.09	124
2 mil mica washer with thermal compound applied to both surfaces; tab screw torqued at 8 inch pound	0.58	131

* A film of air one mil in length has the thermal resistance of ≈ 1.2°C/W.

When using a small heat sink in free air one must consider the additional thermal resistance of the heat sink to ambient and operate at an appropriate power level. For example with an

18°C/W rated sink and thermal compound as above the device will have a junction temperature of 123°C when operating at 5W in an ambient of 25°C free air.