

Product Brief

SDA 9388X

Single-Chip Picture in Picture IC

The SDA 9388X integrates analog (clamping, ADC, DAC, RGB switch) and digital signal processing (decimation, memory, output signal processing etc.) on a single silicon.



SDA

Potential Application

The SDA 9388X is a cost-effective single-chip Picture in Picture IC that requires only a small amount of external components. It is suitable for the following applications:

- TVs for NTSC, PAL M and PAL N markets
- Display and surveillance equipment

Features

- Picture reduction to 1/9, 1/16 and 1/36 of original size
- Freely programmable positioning of PIP on the main picture as well as POP positioning

- PIP frame control including color, shape and width
- Format matching of PIP to 16:9 screen
- Digital signal processing for picture quality optimization
- Three CVBS inputs; analog YUV or RGB output
- Integrated high speed video switch for inserting an external RGB source onto the screen (i.e. OSD)
- I²C-Bus control
- 0.5 μm CMOS technology
- P-DSO-28 package

Documentation and Support Package

- Data sheet
- Technical articles
- PIP module and interface board for evaluation
- SIMON Software for Windows based PC to control evaluation boards via I²C Bus
- SIMON interface module
- Auto demo package for demonstration

SDA 9388X Block Diagram

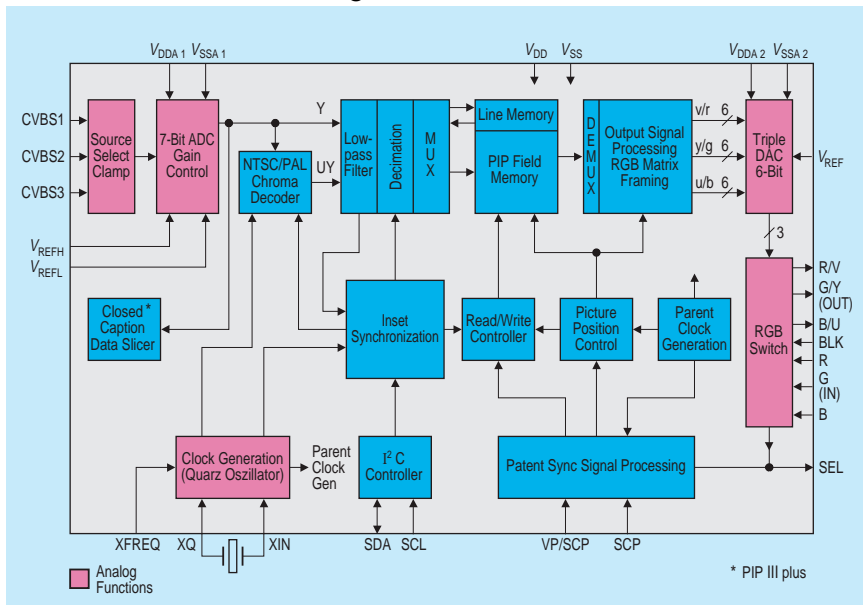

"With our on-chip system solutions we are providing innovative, in every respect optimized key products for the multimedia age. In so doing Siemens Semiconductors is going to get one of the major players in the market of logic ICs."

*Dr. S. Mehrgardt,
President,
Siemens Semiconductors
Signal Processing Division*

The SDA 9388X integrates different functional blocks on a single chip

- Signal clamping and 7-Bit AD Converter
- NTSC/PAL M/ PAL N Chroma decoder
- Decimation logic
- 72-Kbit field memory
- Output signal processing, i.e. peaking
- Triple 6-Bit DA Converter
- RGB Switch
- SYNC processing/generation and memory control logic

Availability

Samples of the SDA 9388X are available with complete documentation for evaluation. SIEMENS' highly experienced engineering support team can assist you with your design in work. Please contact your local Siemens office for further details.

SDA 9388X Application Example

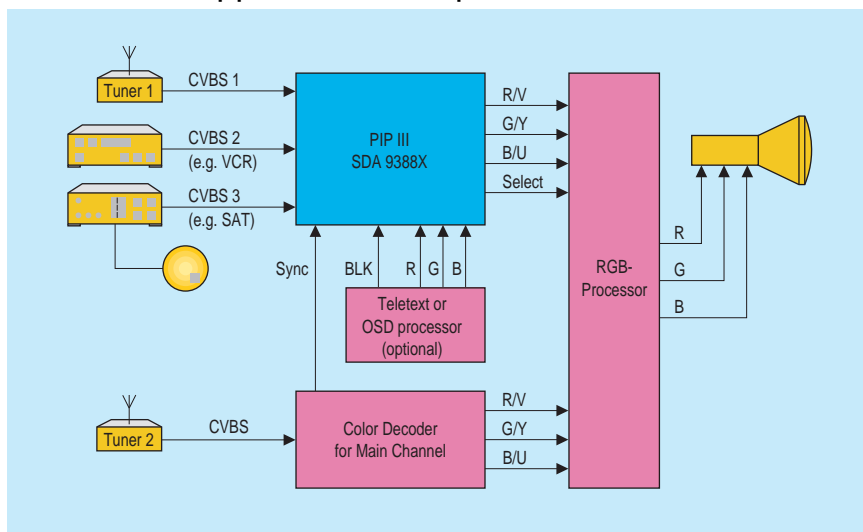

- | | |
|--|--|
| (A) Wien
☎ (+43) 1-1707-356 11 | (IRL) Dublin 4
☎ (+353) 1-603 23 42 |
| (AUS) Richmond (Melbourne), Vic. 3121
☎ (+61) 3-9420 71 11 | (J) Tokyo 141-0022
☎ (+81) 3-5449 64 11 |
| (B) Brussel/Bruelles
☎ (+32) 2-536 23 48 | (MAL) Penang
☎ (+60) 4-644 99 75 |
| (BR) São Paulo-SP
☎ (+55) 11-836 23 77/26 84 | (N) Oslo 5
☎ (+47) 22-63 30 00 |
| (GDN) Mississauga, Ontario L5T 1P2
☎ (+1) 905-819 80 00 | (NL) Den Haag
☎ (+31) 70-333 24 29 |
| (CH) Zürich
☎ (+41) 1-495 30 65 | (NZ) Auckland
☎ (+64) 9-520 30 33 |
| (D) Düsseldorf
☎ (+49) 211-399 15 51
Laatzen (Hannover)
☎ (+49) 511-877 27 06
Nürnberg
☎ (+49) 911-654 76 22
Stuttgart
☎ (+49) 711-137 33 14
München
☎ (+49) 89-9221 40 86 | (P) Amadora
☎ (+35) 1-417 00 11 |
| (DK) Ballerup
☎ (+45) 4477-44 77 | (PK) Islamabad
☎ (+92) 51-21 22 00 |
| (E) Tres Cantos-Madrid
☎ (+34) 91-514 80 00 | (PL) Warszawa
☎ (+48) 2-670 91 51 |
| (F) Saint-Denis CEDEX 2
☎ (+33) 1-4922 31 00 | (RC) Taipei
☎ (+886) 2-2773 66 06 |
| (FIN) Espoo (Helsinki)
☎ (+35) 9-5105 1 | (ROK) Seoul 135-080
☎ (+82) 2-527 77 00 |
| (GB) Berkshire RG 12 8FZ
☎ (+44) 1344-39 60 00 | (RUS) Moskva
☎ (+7) 095-237-64 76, -69 11 |
| (GR) Amaroussio/Athen
☎ (+30) 1-686 41 11 | (S) Kista
☎ (+46) 8-703 35 00 |
| (HK) Hong Kong
☎ (+852) 2832 05 00 | (SGP) Singapore 349 253
☎ (+65) 840 06 10 |
| (I) Milano
☎ (+39) 2-6676-1 | (TR) Findikli (Istanbul)
☎ (+90) 212-251 09 00 |
| (IND) New Delhi 110 014
☎ (+91) 11-461 74 47
Bangalore 560 001
☎ (+91) 80-227 98 74
Mumbai
☎ (+91) 22-496 21 99 | (USA) Cupertino, CA 95014
☎ (+1) 408-777 45 00
Cupertino, CA 95014
☎ (+1) 408-257 79 10
Iselin, NJ 08830-2770
☎ (+1) 732-906 43 00 |
| | (VRC) Beijing
☎ (+86) 10-6857 90-06, -07
Shanghai 200003
☎ (+86) 21-6361 26 18/19
Halfway House 1685
☎ (+27) 11-652-20 00, -27 00 |

How to reach us:
<http://www.siemens.de/semiconductor/address/address.htm>

© Siemens AG 1998.
All Rights Reserved.
Please note that any information contained in this publication may be subject to change. Siemens reserves the right to make changes to or to discontinue any product or service identified in this publication without notice.
Please contact our regional offices to receive the latest version of the relevant information to verify, before placing orders, that the information being relied upon is current.