



VND5050J-E VND5050K-E

Double channel high side driver with analog current sense for automotive applications

Features

General

Max supply voltage	V _{CC}	41V
Operating voltage range	V _{CC}	4.5 to 36V
Max On-State resistance (per ch.)	R _{ON}	50 mΩ
Current limitation (typ)	I _{LIMH}	19 A
Off state supply current	I _S	2 μA ^(*)

(*) Typical value with all loads connected

Application

- All types of resistive, inductive and capacitive loads

Main

- Inrush current active management by power limitation
- Very low stand-by current
- 3.0V CMOS compatible input
- Optimized electromagnetic emission
- Very low electromagnetic susceptibility
- In compliance with the 2002/95/ec european directive

Diagnostic Functions

- Open drain status output
- On state open load detection
- Off state open load detection
- Thermal shutdown indication

Protections

- Undervoltage shut-down
- Overvoltage clamp
- Output stuck to V_{CC} detection
- Load current limitation

Order codes

Package	Part number (Tube)	Part number (Tape & Reel)
PowerSSO-12	VND5050J-E	VND5050J-E13TR
PowerSSO-24	VND5050K-E	VND5050K-E13TR

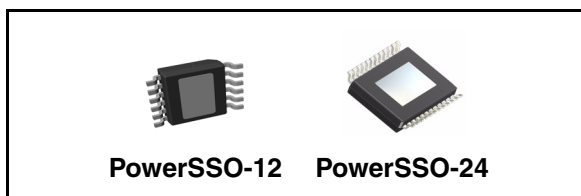

- Self limiting of fast thermal transients
- Protection against loss of ground and loss of V_{CC}
- Thermal shut down
- Reverse battery protection (see [Figure 28](#))
- Electrostatic discharge protection

Description

The VND5050K-E and VND5050J-E is a monolithic device made using STMicroelectronics VIPower M0-5 technology. It is intended for driving resistive or inductive loads with one side connected to ground. Active V_{CC} pin voltage clamp protects the device against low energy spikes (see ISO7637 transient compatibility table). The device detects open load condition both in on and off state, when STAT_DIS is left open or driven low. Output shorted to V_{CC} is detected in the off state.

When STAT_DIS is driven high, STATUS pin is in high impedance state.

Output current limitation protects the device in overload condition. In case of long overload duration, the device limits the dissipated power to safe level up to thermal shut-down intervention. Thermal shut-down with automatic restart allows the device to recover normal operation as soon as fault condition disappears..

Contents

1	Block diagram and pin description	3
2	Electrical specifications	4
2.1	Absolute Maximum Ratings	4
2.2	Thermal Data	5
2.3	Electrical Characteristics	5
2.4	Electrical characteristics curves	12
3	Application information	16
3.1	GND protection network against reverse battery	16
3.1.1	Solution 1:	16
3.1.2	Solution 2:	17
3.2	Load dump protection	17
3.3	μ C I/Os protection:	17
3.4	Open load detection in off state	17
4	Package and PCB thermal data	19
4.1	PowerSSO-12 thermal data	19
4.2	PowerSSO-24 thermal data	21
5	Package information	23
5.1	Package Mechanical	23
5.2	Packing information	25
6	Revision history	27

1 Block diagram and pin description

Figure 1. Block Diagram

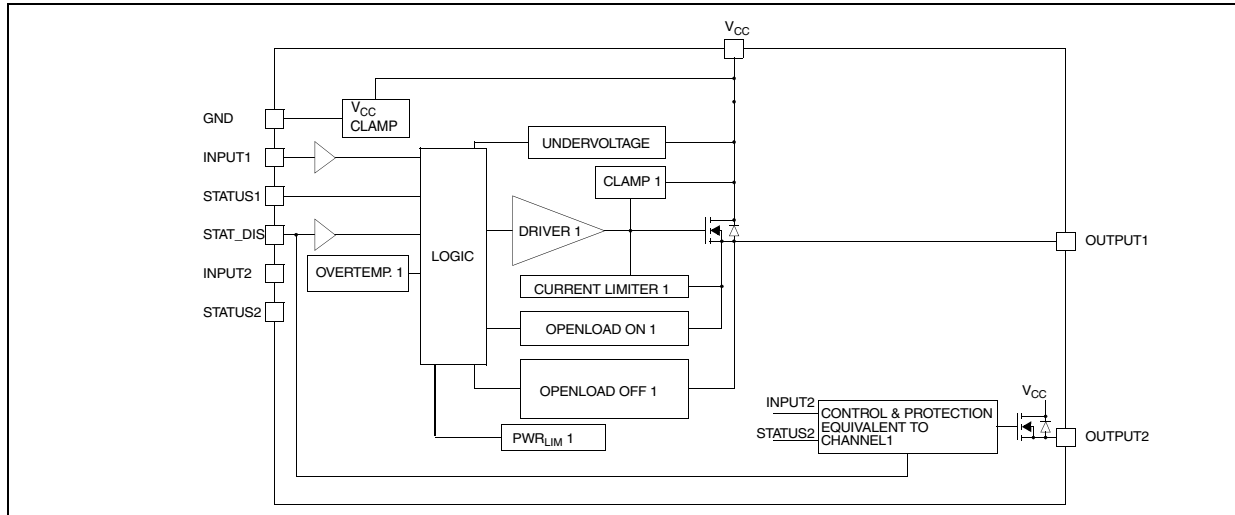
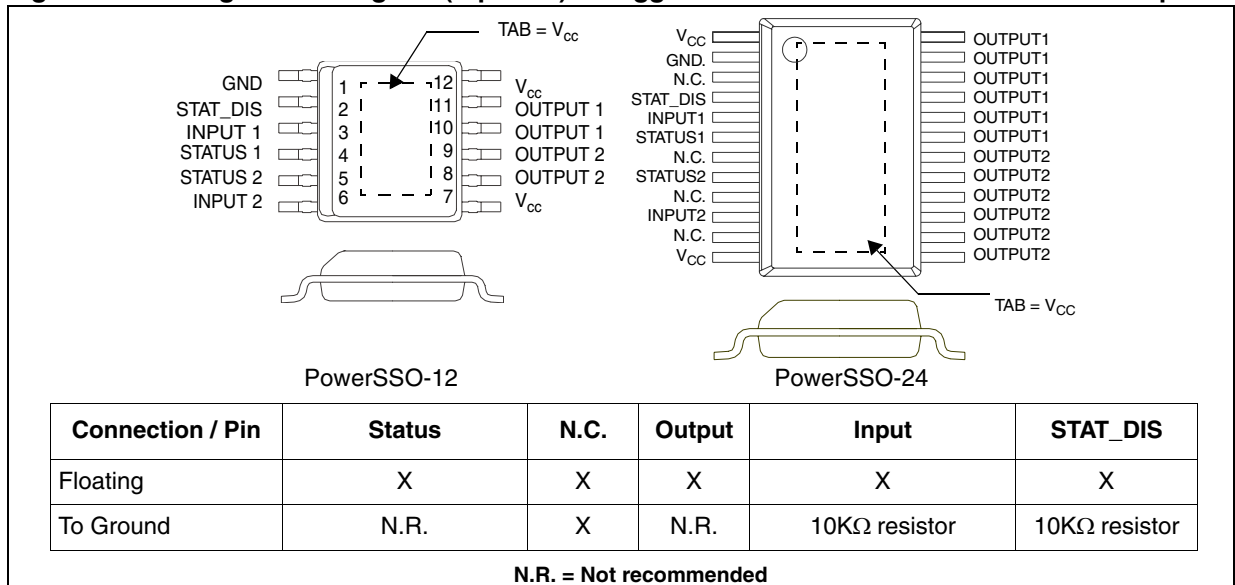

Table 1. Pin Function

Name	Function
V _{CC}	Battery connection
OUTPUT _n	Power output
GND	Ground connection. Must be reverse battery protected by an external diode/resistor network
INPUT _n	Voltage controlled input pin with hysteresis, CMOS compatible. Controls output switch state
STATUS _n	Open drain digital diagnostic pin
STAT_DIS	Active high CMOS compatible pin, to disable the STATUS pin

Figure 2. Configuration diagram (top view) & suggested connections for unused and n.c. pins



2 Electrical specifications

Figure 3. Current and Voltage Conventions

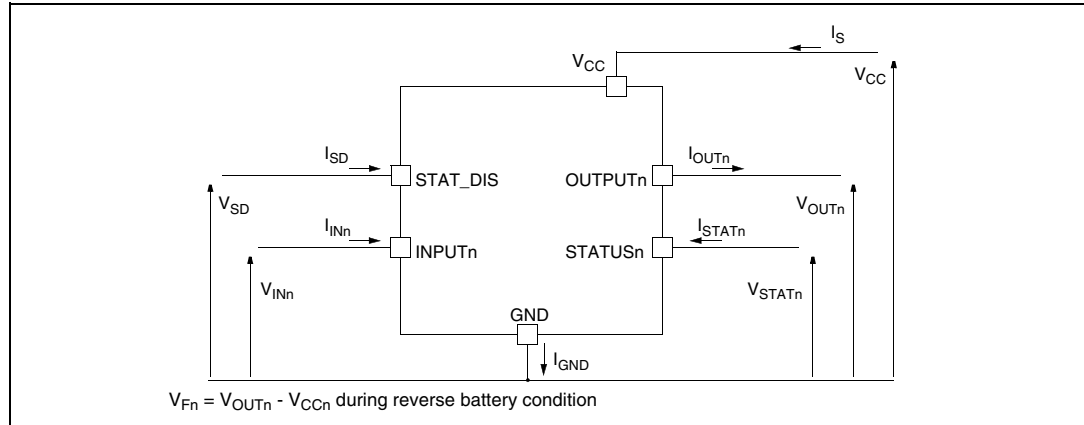

2.1 Absolute Maximum Ratings

Table 2. Absolute Maximum Ratings

Symbol	Parameter	Value	Unit
V_{CC}	DC Supply Voltage	41	V
$-V_{CC}$	Reverse DC Supply Voltage	0.3	V
$-I_{GND}$	DC Reverse Ground Pin Current	200	mA
I_{OUT}	DC Output Current	Internally Limited	A
$-I_{OUT}$	Reverse DC Output Current	15	A
I_{IN}	DC Input Current	+10 / -1	mA
I_{STAT}	DC Status Current	+10 / -1	mA
I_{STAT_DIS}	DC Status Disable Current	+10 / -1	mA
E_{MAX}	Maximum switching energy ($L=1.5mH$; $R_L=0\Omega$; $V_{bat}=13.5V$; $T_{jstart}=150^\circ C$; $I_{OUT} = I_{limL}(Typ.)$)	51	mJ
V_{ESD}	Electrostatic Discharge (Human Body Model: $R=1.5K\Omega$; $C=100pF$)		
	- INPUT	4000	V
	- STATUS	4000	V
	- STAT_DIS	4000	V
	- OUTPUT	5000	V
V_{ESD}	- V_{CC}	5000	V
V_{ESD}	Charge device model (CDM-AEC-Q100-011)	750	V
T_j	Junction Operating Temperature	-40 to 150	$^\circ C$
T_{stg}	Storage Temperature	- 55 to 150	$^\circ C$

2.2 Thermal Data

Table 3. Thermal Data

Symbol	Parameter	Value		Unit
		PowerSSO-12	PowerSSO-24	
$R_{thj-case}$	Thermal resistance junction-case (Max.) (with one channel ON)	2.8	2.8	°C/W
$R_{thj-amb}$	Thermal resistance junction-ambient (Max.)	See Figure 31	See Figure 35	°C/W

2.3 Electrical Characteristics

$8V < V_{CC} < 36V$; $-40^{\circ}C < T_j < 150^{\circ}C$, unless otherwise specified.

Table 4. Power section

Symbol	Parameter	Test Conditions	Min.	Typ.	Max.	Unit
V_{CC}	Operating supply voltage		4.5	13	36	V
V_{USD}	Undervoltage shutdown			3.5	4.5	V
$V_{USDhyst}$	Undervoltage shut-down hysteresis			0.5		V
R_{ON}	On state resistance ⁽²⁾	$I_{OUT}=2A$; $T_j=25^{\circ}C$ $I_{OUT}=2A$; $T_j=150^{\circ}C$ $I_{OUT}=2A$; $V_{CC}=5V$; $T_j=25^{\circ}C$			50 100 65	mΩ mΩ mΩ
V_{clamp}	Clamp Voltage	$I_S=20mA$	41	46	52	V
I_S	Supply current	Off State; $V_{CC}=13V$; $T_j=25^{\circ}C$; $V_{IN}=V_{OUT}=V_{SENSE}=V_{CSD}=0V$ On State; $V_{CC}=13V$; $V_{IN}=5V$; $I_{OUT}=0A$		2 ⁽¹⁾ 3	5 ⁽¹⁾ 6	μA mA
$I_{L(off1)}$	Off state output current ⁽²⁾	$V_{IN}=V_{OUT}=0V$; $V_{CC}=13V$; $T_j=25^{\circ}C$ $V_{IN}=V_{OUT}=0V$; $V_{CC}=13V$; $T_j=125^{\circ}C$	0 0	0.01	3 5	μA
$I_{L(off2)}$	Off state output current ⁽²⁾	$V_{IN}=0V$; $V_{OUT}=4V$	-75		0	
V_F	Output - V_{CC} diode voltage ⁽²⁾	$-I_{OUT}=4A$; $T_j=150^{\circ}C$			0.7	V

(1) PowerMOS leakage included.

(2) For each channel

Table 5. Switching ($V_{CC}=13V$)

Symbol	Parameter	Test Conditions	Min.	Typ.	Max.	Unit
$t_{d(on)}$	Turn-on delay time	$R_L=6.5\Omega$ (see Figure 5)		20		μs
$t_{d(off)}$	Turn-off delay time	$R_L=6.5\Omega$ (see Figure 5)		40		μs
$dV_{OUT}/dt_{(on)}$	Turn-on voltage slope	$R_L=6.5\Omega$		see Figure 22		V/μs
$dV_{OUT}/dt_{(off)}$	Turn-off voltage slope	$R_L=6.5\Omega$		see Figure 24		V/μs

Table 5. Switching ($V_{CC}=13V$) (continued)

Symbol	Parameter	Test Conditions	Min.	Typ.	Max.	Unit
W_{ON}	Switching energy losses during t_{won}	$R_L=6.5\Omega$ (see Figure 5)		0.21		mJ
W_{OFF}	Switching energy losses during t_{woff}	$R_L=6.5\Omega$ (see Figure 5)		0.28		mJ

Table 6. Status Pin ($V_{SD}=0V$)

Symbol	Parameter	Test Conditions	Min	Typ	Max	Unit
V_{STAT}	Status Low Output Voltage	$I_{STAT}=1.6\text{ mA}$, $V_{SD}=0V$			0.5	V
I_{LSTAT}	Status Leakage Current	Normal Operation or $V_{SD}=5V$, $V_{STAT}=5V$			10	μA
C_{STAT}	Status Pin Input Capacitance	Normal Operation or $V_{SD}=5V$, $V_{STAT}=5V$			100	pF
V_{SCL}	Status Clamp Voltage	$I_{STAT}=1\text{ mA}$ $I_{STAT}=-1\text{ mA}$	5.5	-0.7	7	V V

Table 7. Protections (1)

Symbol	Parameter	Test Conditions	Min.	Typ.	Max.	Unit
I_{limH}	DC Short circuit current	$V_{CC}=13V$ $5V < V_{CC} < 36V$	12	18	24 24	A A
I_{limL}	Short circuit current during thermal cycling	$V_{CC}=13V$ $T_R < T_j < T_{TSD}$		7		A
T_{TSD}	Shutdown temperature		150	175	200	$^{\circ}C$
T_R	Reset temperature		$T_{RS} + 1$	$T_{RS} + 5$		$^{\circ}C$
T_{RS}	Thermal reset of STATUS		135			$^{\circ}C$
T_{HYST}	Thermal hysteresis ($T_{TSD} - T_R$)			7		$^{\circ}C$
t_{SDL}	Status Delay in Overload Conditions	$T_j > T_{TSD}$ (see Figure 4)			20	μs
V_{DEMAG}	Turn-off output voltage clamp	$I_{OUT}=2A$; $V_{IN}=0$; $L=6\text{mH}$	$V_{CC}-41$	$V_{CC}-46$	$V_{CC}-52$	V
V_{ON}	Output voltage drop limitation	$I_{OUT}=0.1A$; $T_j = -40^{\circ}C \dots +150^{\circ}C$ (see Figure 6)		25		mV

(1) To ensure long term reliability under heavy overload or short circuit conditions, protection and related diagnostic signals must be used together with a proper software strategy. If the device is subjected to abnormal conditions, this software must limit the duration and number of activation cycles

Table 8. Openload Detection

Symbol	Parameter	Test Conditions	Min	Typ	Max	Unit
I_{OL}	Openload ON State Detection Threshold	$V_{IN} = 5V, 8V < V_{CC} < 18V$	10	See Figure 19	70	mA
$t_{DOL(on)}$	Openload ON State Detection Delay	$I_{OUT} = 0A, V_{CC} = 13V$ (see Figure 4)			200	μs
t_{POL}	Delay between INPUT falling edge and STATUS rising edge in Openload condition	$I_{OUT} = 0A$ (see Figure 4)	200	500	1000	μs
V_{OL}	Openload OFF State Voltage Detection Threshold	$V_{IN} = 0V, 8V < V_{CC} < 16V$	2	See Figure 20	4	V
t_{DSTKON}	Output Short Circuit to V_{CC} Detection Delay at Turn Off	(see Figure 4)	180		t_{POL}	μs

Table 9. Logic input

Symbol	Parameter	Test Conditions	Min.	Typ.	Max.	Unit
V_{IL}	Input Low Level				0.9	V
I_{IL}	Low Level Input Current	$V_{IN} = 0.9V$	1			μA
V_{IH}	Input High Level		2.1			V
I_{IH}	High Level Input Current	$V_{IN} = 2.1V$			10	μA
$V_{I(hyst)}$	Input Hysteresis Voltage		0.25			V
V_{ICL}	Input Clamp Voltage	$I_{IN} = 1mA$ $I_{IN} = -1mA$	5.5	-0.7	7	V V
V_{SDL}	STAT_DIS low level voltage				0.9	V
I_{SDL}	Low level STAT_DIS current	$V_{SD} = 0.9V$	1			μA
V_{SDH}	STAT_DIS high level voltage		2.1			V
I_{SDH}	High level STAT_DIS current	$V_{SD} = 2.1V$			10	μA
$V_{SD(hyst)}$	STAT_DIS hysteresis voltage		0.25			V
V_{SDCL}	STAT_DIS clamp voltage	$I_{SD} = 1mA$ $I_{SD} = -1mA$	5.5	-0.7	7	V V

Figure 4. Status Timings

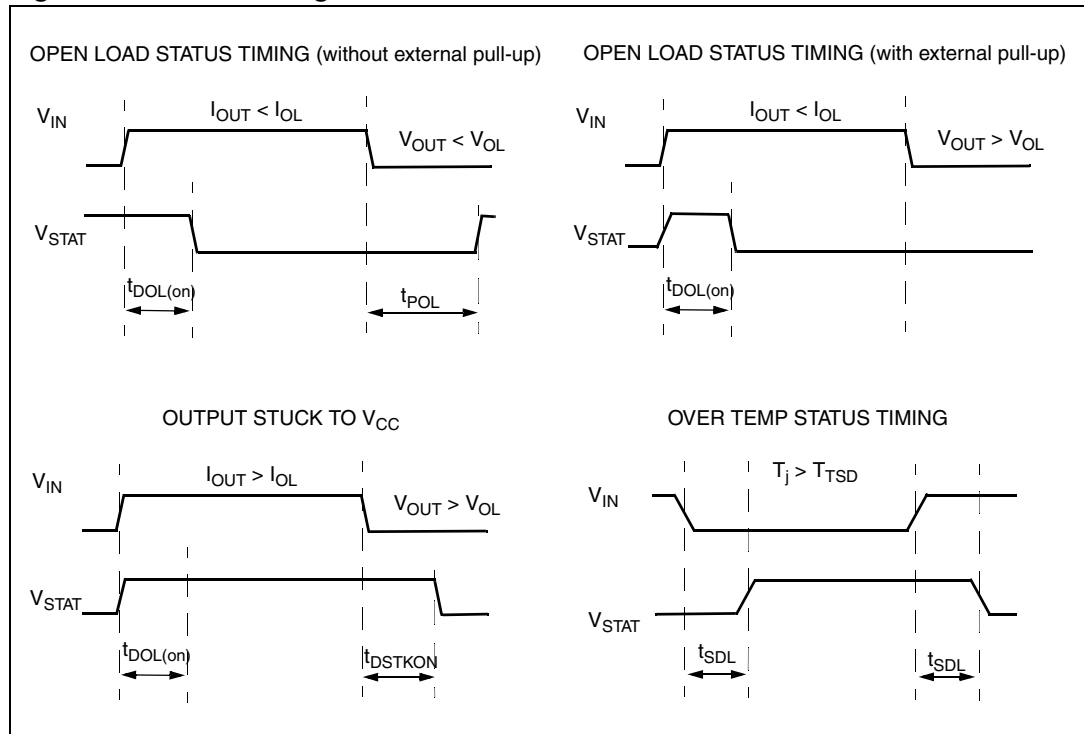

Table 10. Truth table

CONDITIONS	INPUT	OUTPUT	SENSE ($V_{CSD}=0V$) ⁽¹⁾
Normal Operation	L	L	H
	H	H	H
Current Limitation	L	L	H
	H	X	H
Overtemperature	L	L	H
	H	L	L
Undervoltage	L	L	X
	H	L	X
Output Voltage > V_{OL}	L	H	L ⁽²⁾
	H	H	H
Output Current < I_{OL}	L	L	H ⁽³⁾
	H	H	L

(1) If the V_{CSD} is high, the SENSE output is at a high impedance, its potential depends on leakage currents and external circuit.

(2) The STATUS pin is low with a delay equal to t_{DSTKON} after INPUT falling edge.

(3) The STATUS pin becomes high with a delay equal to t_{POL} after INPUT falling edge.

Figure 5. Switching characteristics

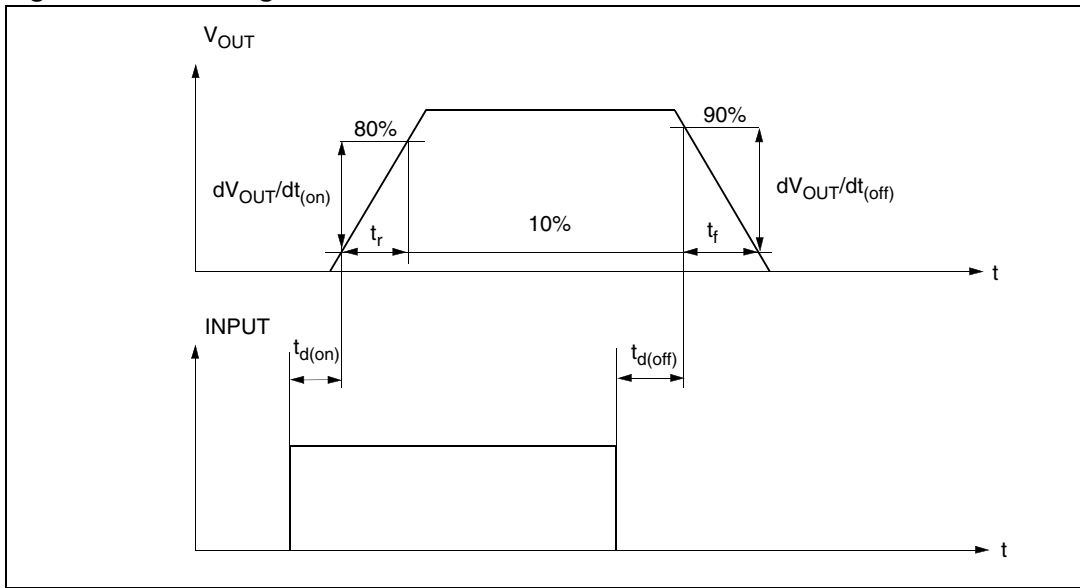

Figure 6. Output Voltage Drop Limitation

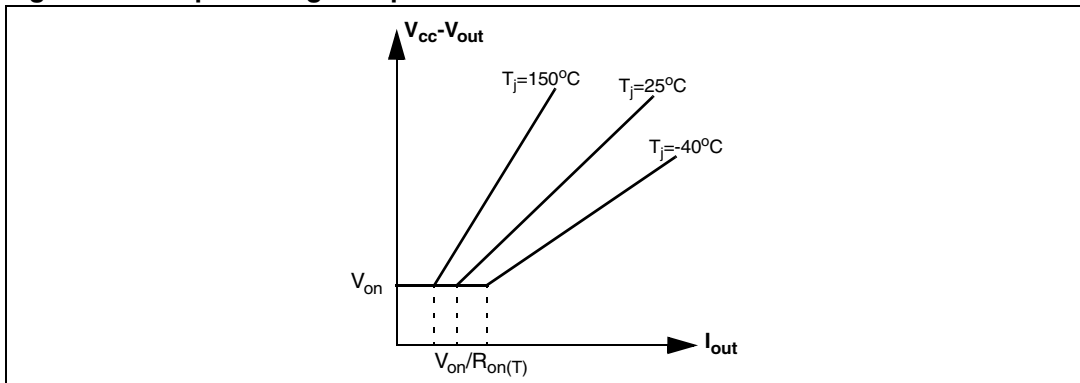

Table 11. Electrical Transient Requirements

ISO 7637-2: 2004(E) Test Pulse	TEST LEVELS		Number of pulses or test times	Burst cycle/pulse repetition time		Delays and Impedance
	III	IV				
1	-75V	-100V	5000 pulses	0.5 s	5 s	2 ms, 10 Ω
2a	+37V	+50V	5000 pulses	0.2 s	5 s	50 μ s, 2 Ω
3a	-100V	-150V	1h	90 ms	100 ms	0.1 μ s, 50 Ω
3b	+75V	+100V	1h	90 ms	100 ms	0.1 μ s, 50 Ω
4	-6V	-7V	1 pulse			100 ms, 0.01 Ω
5b ⁽¹⁾	+40V	+40V	1 pulse			400 ms, 2 Ω

ISO 7637-2: 2004(E) Test Pulse	TEST LEVEL RESULTS	
	III	IV
1	C	C
2a	C	C
3a	C	C
3b	C	C
4	C	C
5b ⁽¹⁾	C	C

CLASS	CONTENTS
C	All functions of the device are performed as designed after exposure to disturbance.
E	One or more functions of the device are not performed as designed after exposure to disturbance and cannot be returned to proper operation without replacing the device.

(1) For load dump exceeding the above value a centralized suppressor must be adopted.

Figure 7. Waveforms

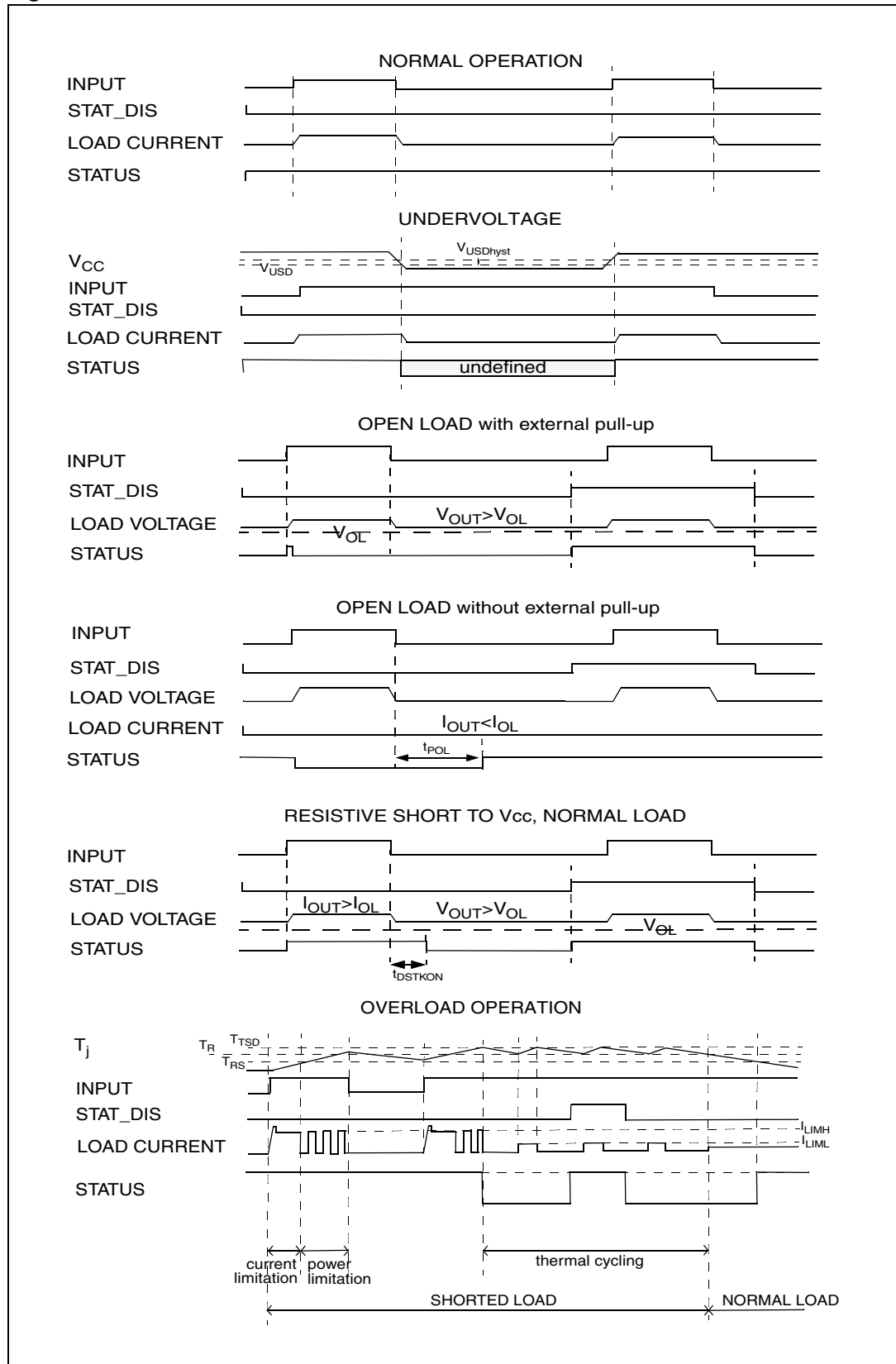

2.4 Electrical characteristics curves

Figure 8. Off State Output Current

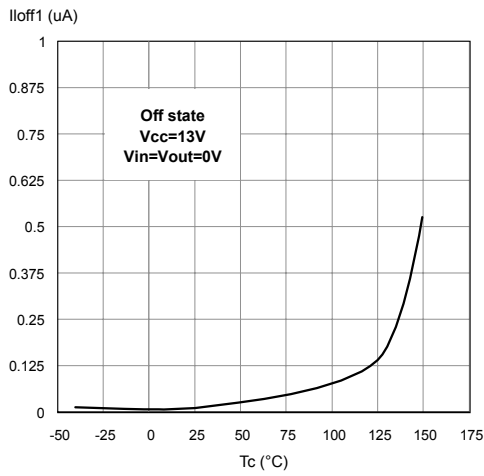

Figure 10. Input Clamp Voltage

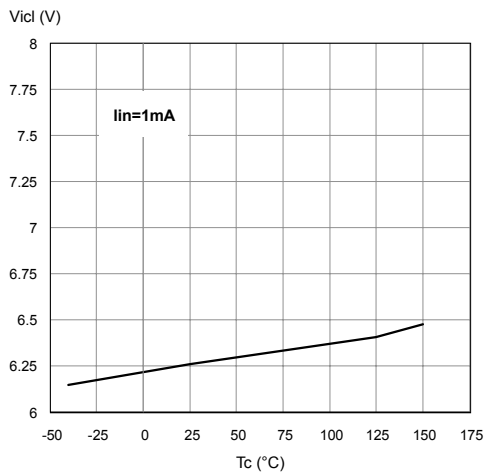

Figure 12. Input Low Level

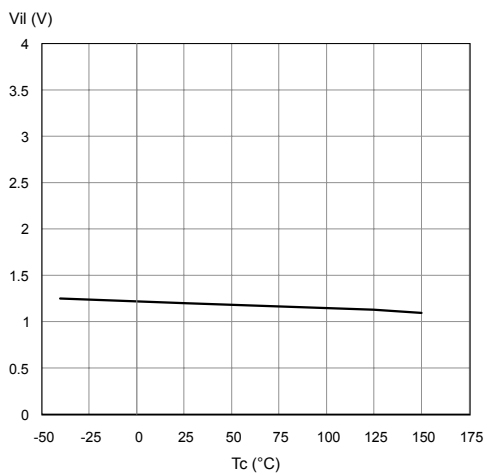

Figure 9. High Level Input Current

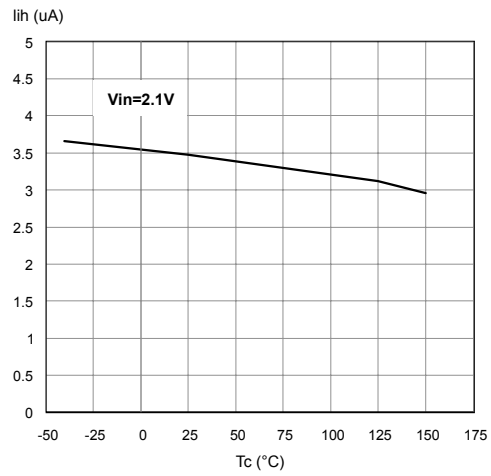

Figure 11. Input High Level

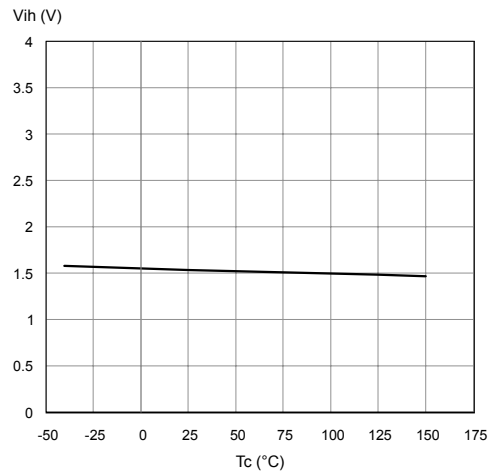

Figure 13. Input Hysteresis Voltage

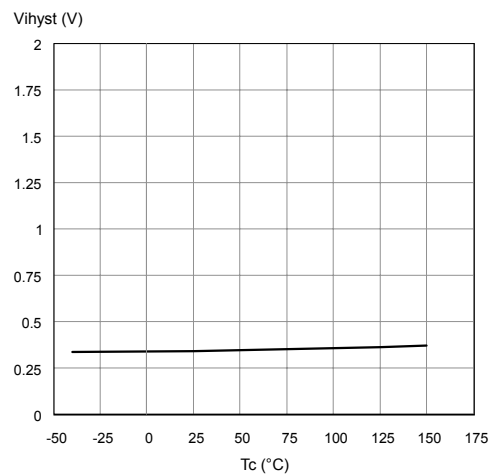

Figure 14. Status Low Output Voltage

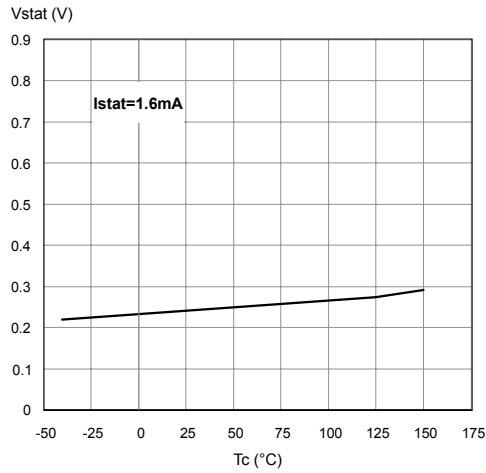

Figure 15. On State Resistance Vs T_{case}

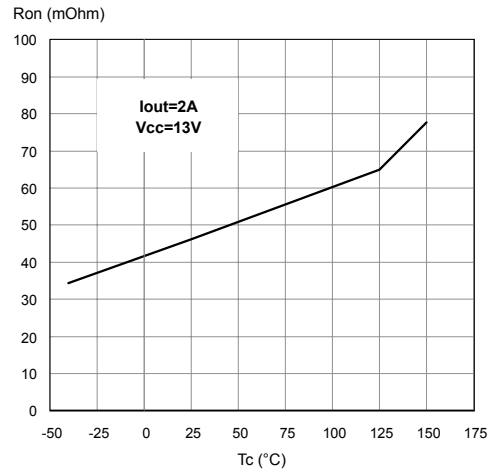

Figure 16. Status Leakage Current

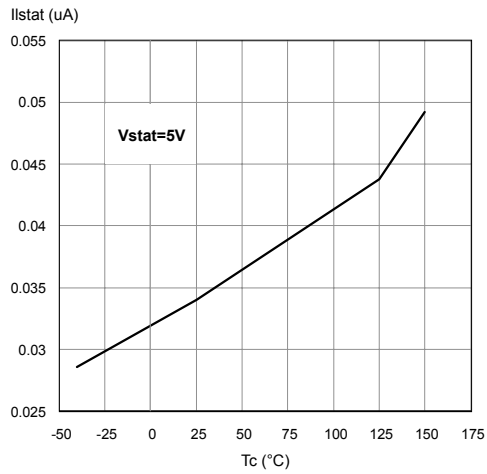

Figure 17. On State Resistance Vs V_{CC}

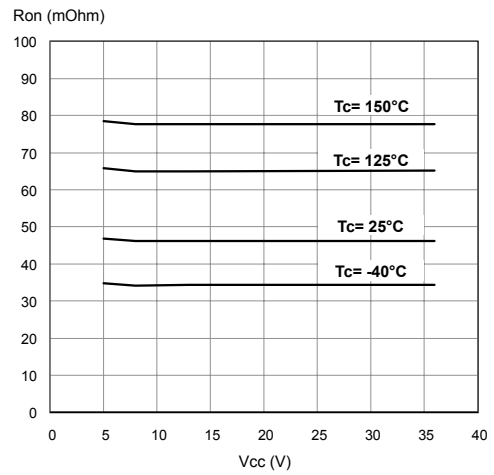

Figure 18. Status Clamp Voltage

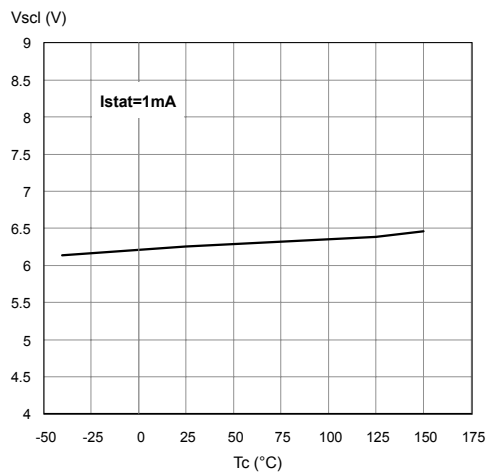

Figure 19. Openload On State Detection Threshold

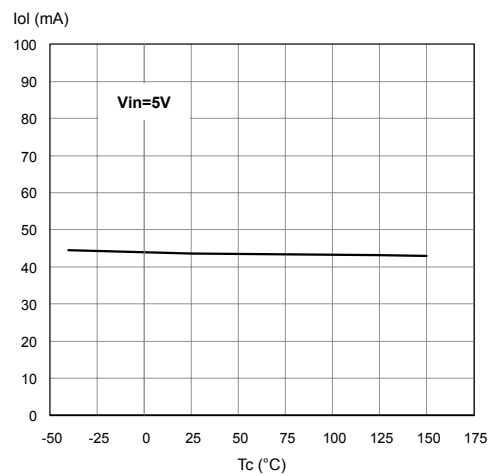

Figure 20. Openload Off State Voltage Detection Threshold

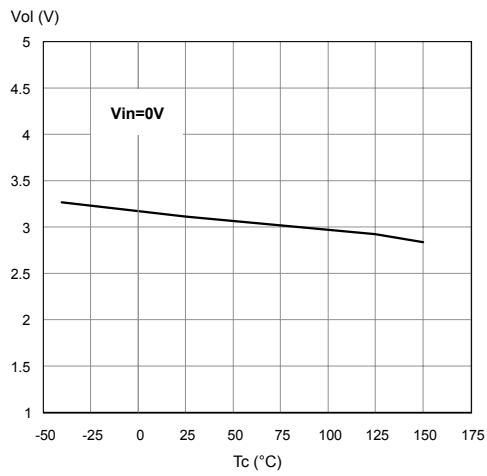

Figure 21. I_{LIM} Vs T_{case}

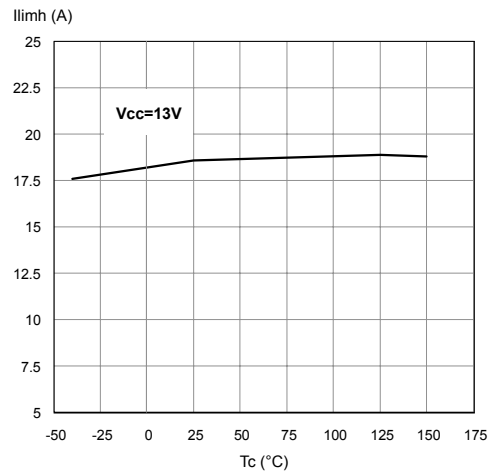

Figure 22. Turn-on Voltage Slope

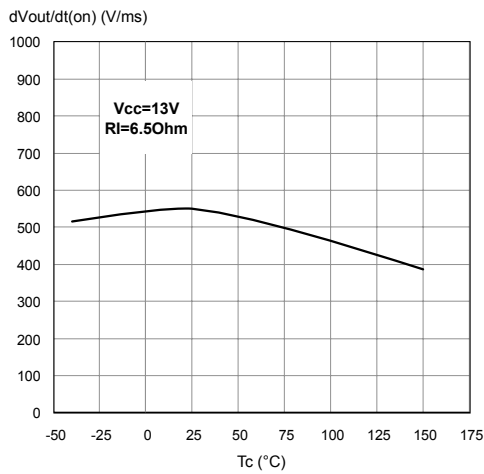

Figure 23. Undervoltage Shutdown

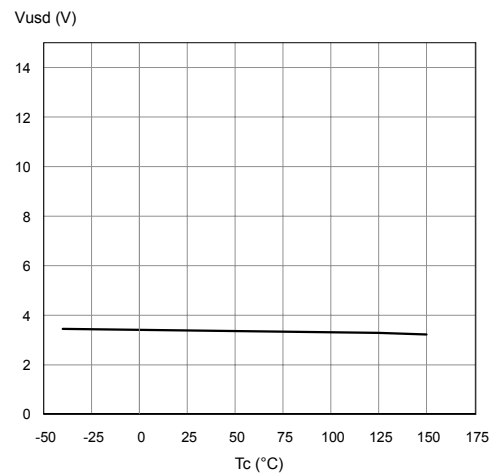

Figure 24. Turn-off Voltage Slope

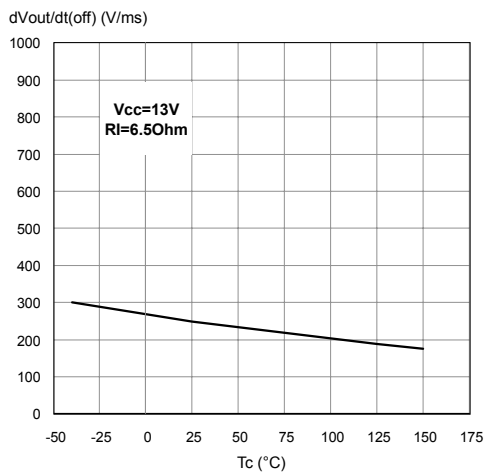

Figure 25. STAT_DIS Clamp Voltage

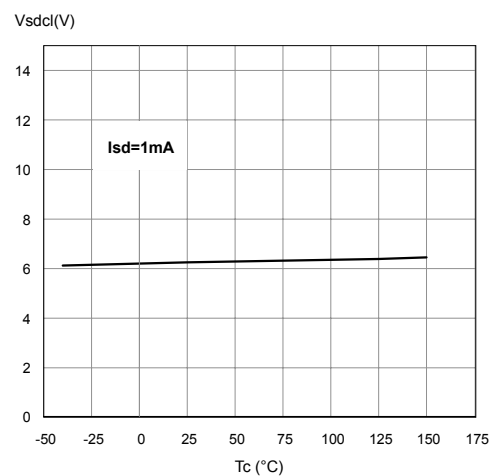

Figure 26. High Level STAT_DIS Voltage

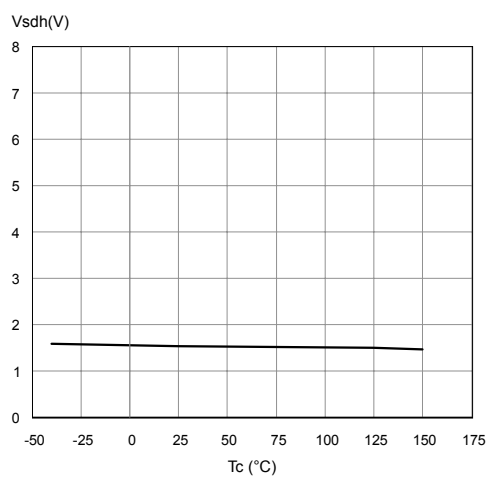
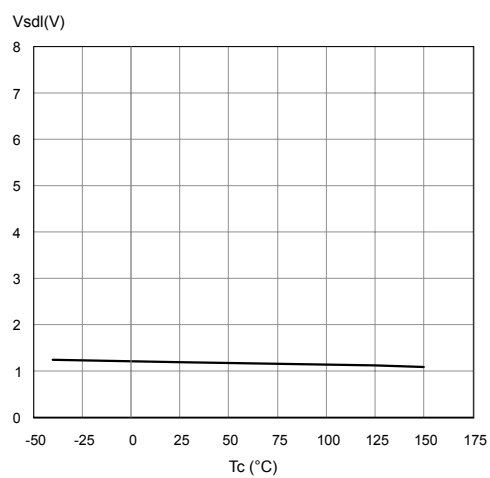
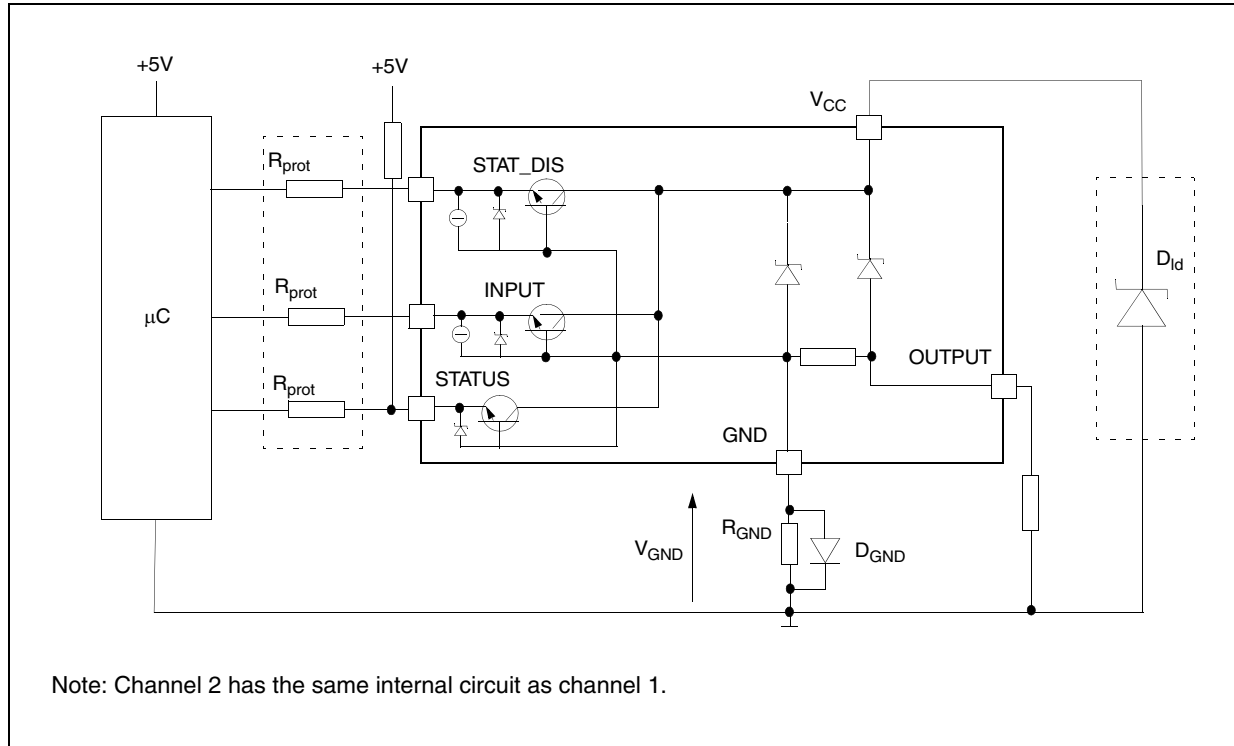

Figure 27. Low Level STAT_DIS Voltage



3 Application information

Figure 28. Application schematic



3.1 GND protection network against reverse battery

3.1.1 Solution 1:

Resistor in the ground line (R_{GND} only). This can be used with any type of load.

The following is an indication on how to dimension the R_{GND} resistor.

1. $R_{GND} \leq 600\text{mV} / (I_{S(on)max})$.
2. $R_{GND} \geq (-V_{CC}) / (-I_{GND})$

where $-I_{GND}$ is the DC reverse ground pin current and can be found in the absolute maximum rating section of the device datasheet.

Power Dissipation in R_{GND} (when $V_{CC} < 0$: during reverse battery situations) is:

$$P_D = (-V_{CC})^2 / R_{GND}$$

This resistor can be shared amongst several different HSDs. Please note that the value of this resistor should be calculated with formula (1) where $I_{S(on)max}$ becomes the sum of the maximum on-state currents of the different devices.

Please note that if the microprocessor ground is not shared by the device ground then the R_{GND} will produce a shift ($I_{S(on)max} * R_{GND}$) in the input thresholds and the status output values. This shift will vary depending on how many devices are ON in the case of several high side drivers sharing the same R_{GND} .

If the calculated power dissipation leads to a large resistor or several devices have to share the same resistor then ST suggests to utilize Solution 2 (see below).

3.1.2 Solution 2:

A diode (D_{GND}) in the ground line.

A resistor ($R_{GND}=1k\Omega$) should be inserted in parallel to D_{GND} if the device drives an inductive load.

This small signal diode can be safely shared amongst several different HSDs. Also in this case, the presence of the ground network will produce a shift ($\approx 600mV$) in the input threshold and in the status output values if the microprocessor ground is not common to the device ground. This shift will not vary if more than one HSD shares the same diode/resistor network.

3.2 Load dump protection

D_{ld} is necessary (Voltage Transient Suppressor) if the load dump peak voltage exceeds the V_{CC} max DC rating. The same applies if the device is subject to transients on the V_{CC} line that are greater than the ones shown in the ISO 7637-2: 2004(E) table.

3.3 μC I/Os protection:

If a ground protection network is used and negative transients are present on the V_{CC} line, the control pins will be pulled negative. ST suggests to insert a resistor (R_{prot}) in line to prevent the μC I/Os pins to latch-up.

The value of these resistors is a compromise between the leakage current of μC and the current required by the HSD I/Os (Input levels compatibility) with the latch-up limit of μC I/Os.

$$-V_{CCpeak}/I_{latchup} \leq R_{prot} \leq (V_{OH\mu C} - V_{IH} - V_{GND}) / I_{IHmax}$$

Calculation example:

For $V_{CCpeak} = -100V$ and $I_{latchup} \geq 20mA$; $V_{OH\mu C} \geq 4.5V$

$$5k\Omega \leq R_{prot} \leq 180k\Omega$$

Recommended values: $R_{prot} = 10k\Omega$, $C_{EXT} = 10nF$.

3.4 Open load detection in off state

Off state open load detection requires an external pull-up resistor (R_{PU}) connected between OUTPUT pin and a positive supply voltage (V_{PU}) like the +5V line used to supply the microprocessor.

The external resistor has to be selected according to the following requirements:

- no false open load indication when load is connected: in this case we have to avoid V_{OUT} to be higher than V_{OLmin} ; this results in the following condition $V_{OUT} = (V_{PU} / (R_L + R_{PU})) R_L < V_{OLmin}$.
- no misdetection when load is disconnected: in this case the V_{OUT} has to be higher than V_{OLmax} ; this results in the following condition $R_{PU} < (V_{PU} - V_{OLmax}) / I_{L(off2)}$.

Because $I_{S(OFF)}$ may significantly increase if V_{out} is pulled high (up to several mA), the pull-up resistor R_{PU} should be connected to a supply that is switched OFF when the module is in standby.

The values of V_{OLmin} , V_{OLmax} and $I_{L(off2)}$ are available in the Electrical Characteristics section.

Figure 29. Open Load detection in off state

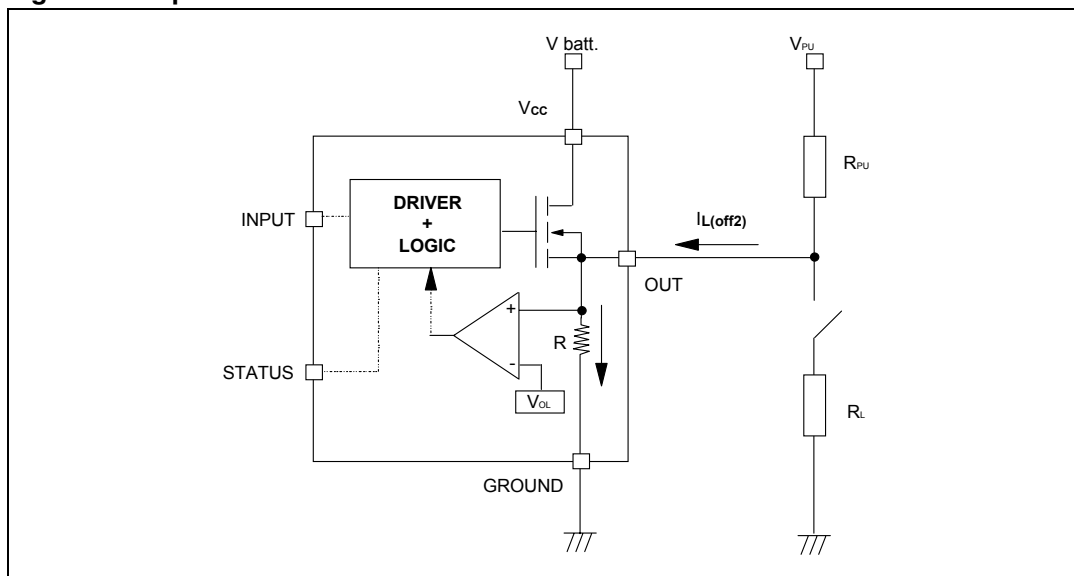

4 Package and PCB thermal data

4.1 PowerSSO-12 thermal data

Figure 30. PowerSSO-12 PC Board

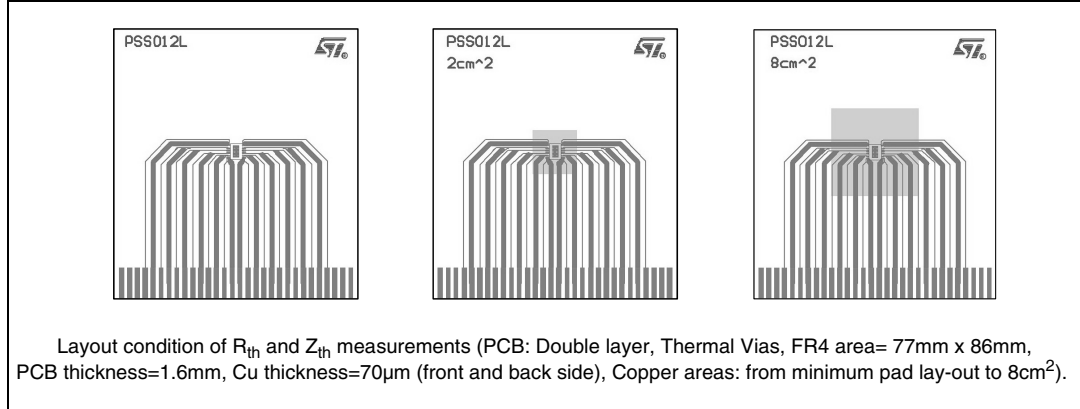

Figure 31. $R_{thj-amb}$ Vs. PCB copper area in open box free air condition

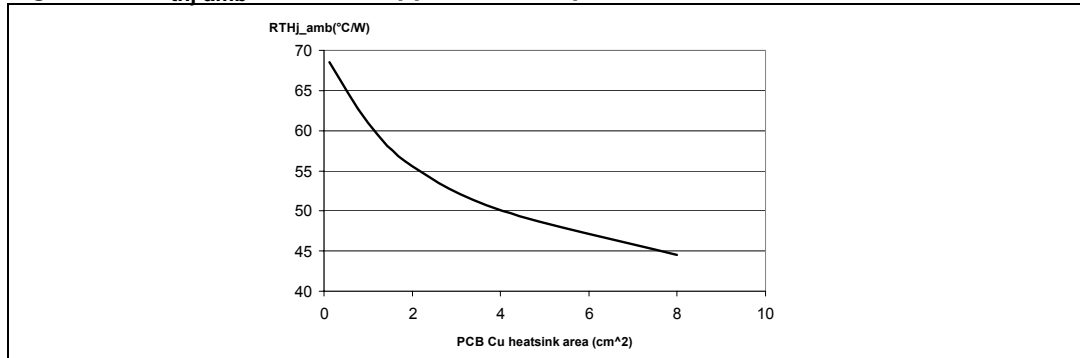
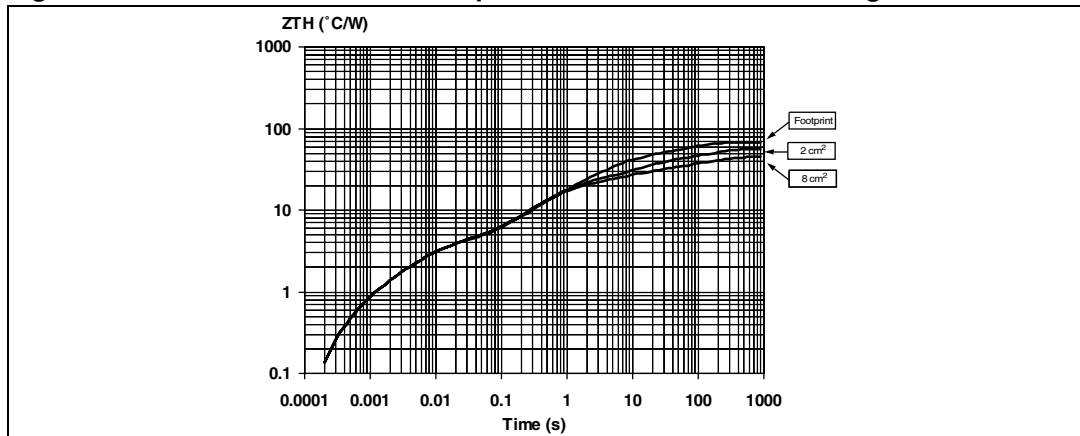

Figure 32. PowerSSO-12 Thermal Impedance Junction Ambient Single Pulse



Pulse Calculation Formula

$$Z_{TH\delta} = R_{TH} \cdot \delta + Z_{THtp}(1 - \delta)$$

where $\delta = t_p/T$

Figure 33. Thermal Fitting Model of a Double Channel HSD in PowerSSO-12

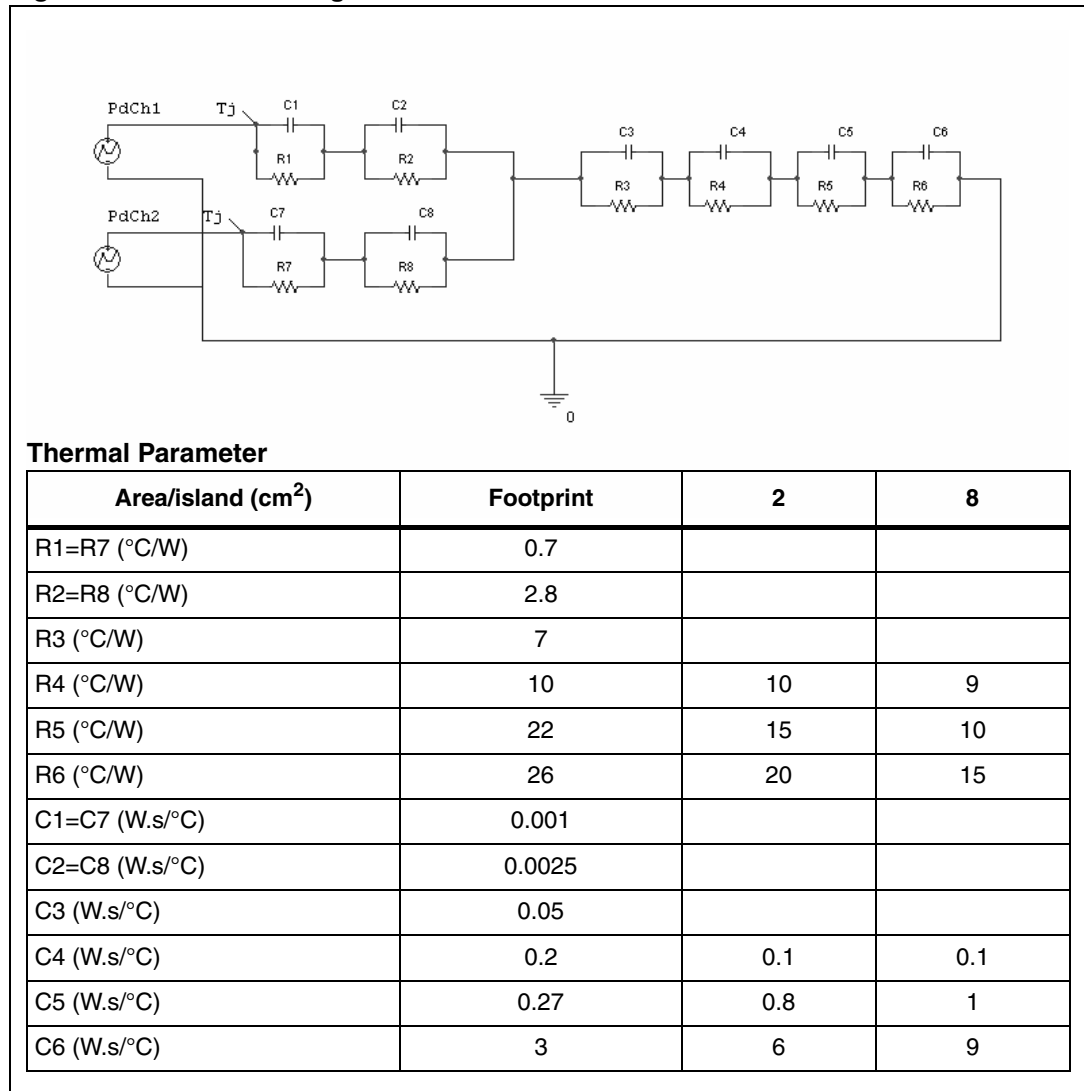

4.2 PowerSSO-24 thermal data

Figure 34. PowerSSO-24 PC Board

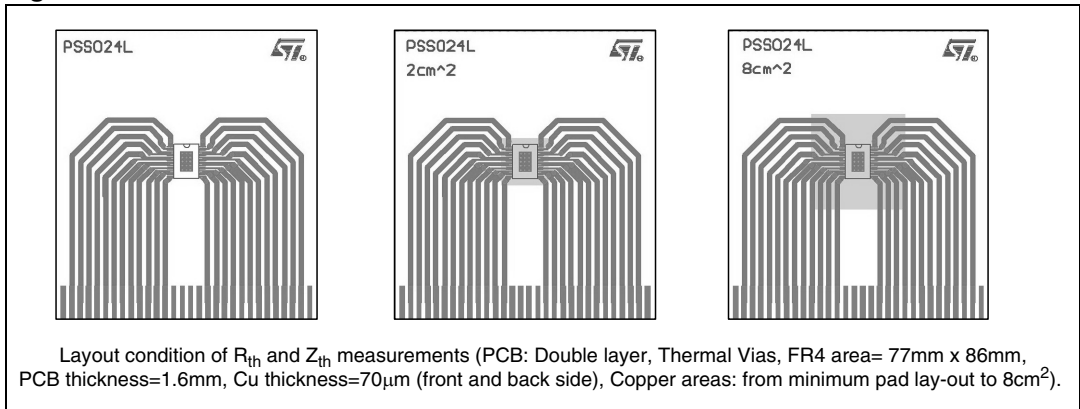

Figure 35. $R_{thj-amb}$ Vs. PCB copper area in open box free air condition

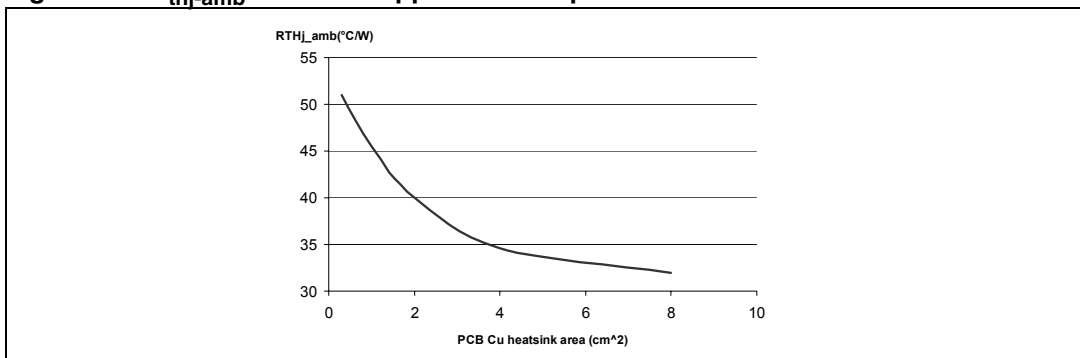
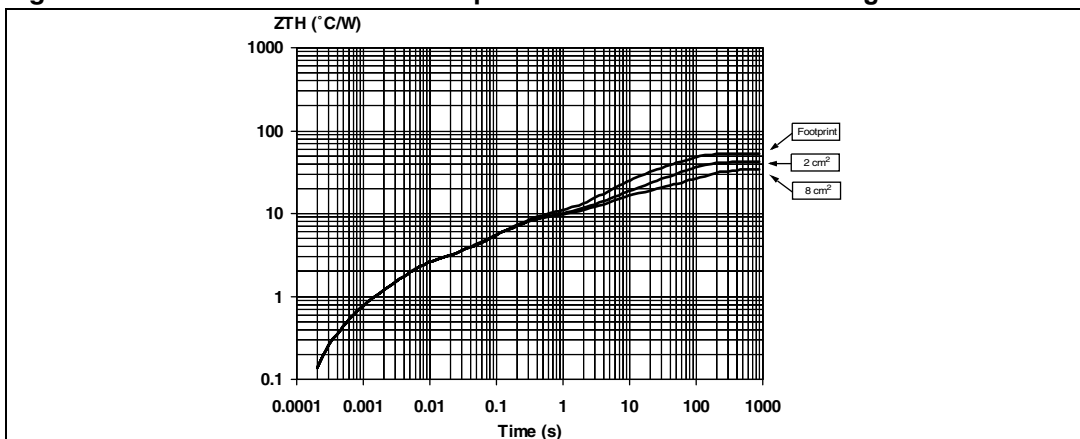

Figure 36. PowerSSO-24 Thermal Impedance Junction Ambient Single Pulse



Pulse Calculation Formula

$$Z_{TH\delta} = R_{TH} \cdot \delta + Z_{THtp}(1 - \delta)$$

where $\delta = t_p/T$

Figure 37. Thermal Fitting Model of a Single Channel HSD in PowerSSO-12

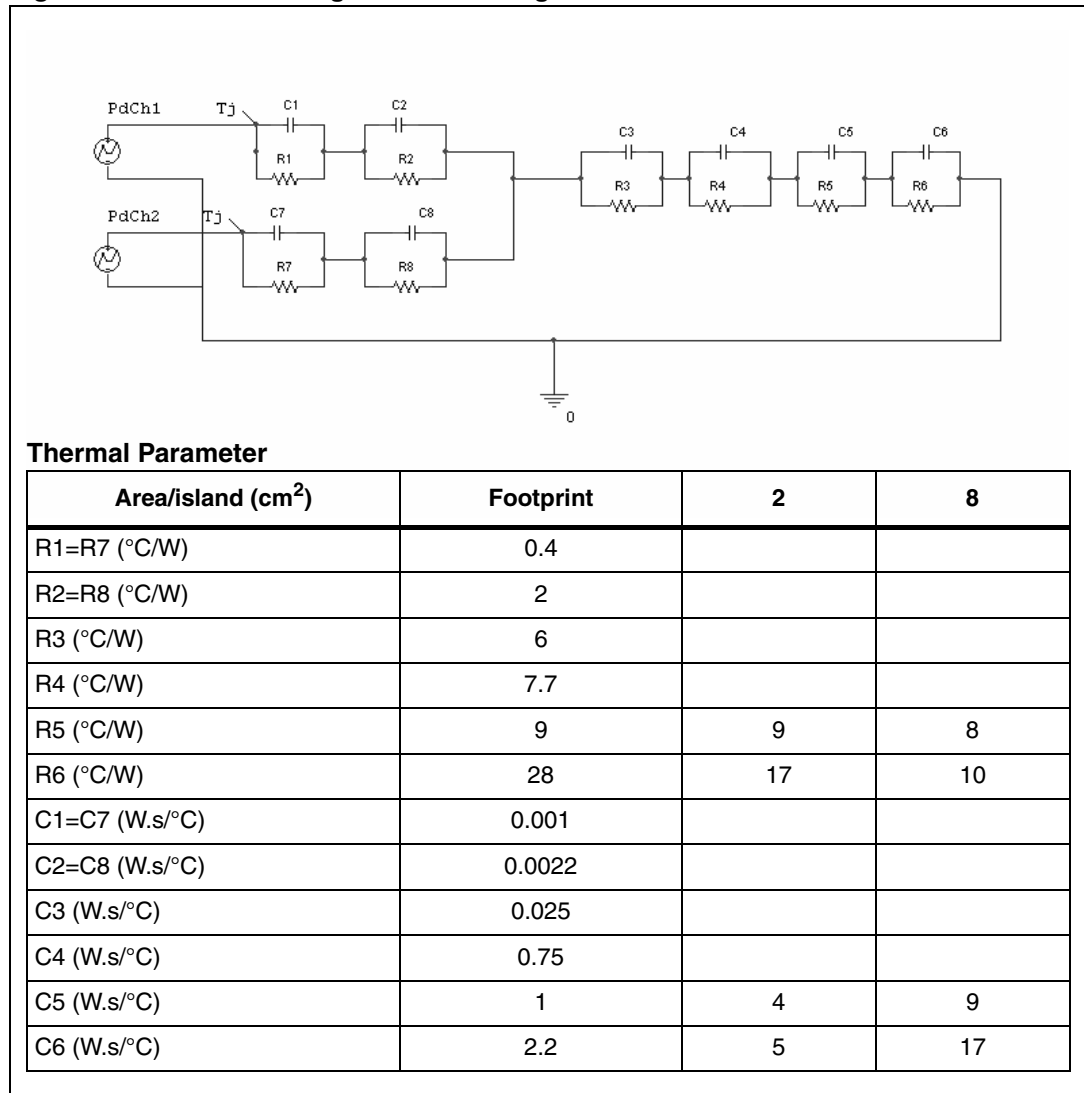

5 Package information

In order to meet environmental requirements, ST offers these devices in ECOPACK® packages. These packages have a Lead-free second-level interconnect. The category of Second-Level Interconnect is marked on the package and on the inner box label, in compliance with JEDEC Standard JESD97.

The maximum ratings related to soldering conditions are also marked on the inner box label. ECOPACK is an ST trademark. ECOPACK specifications are available at: www.st.com.

5.1 Package Mechanical

Figure 38. PowerSSO-12™ Package Dimensions

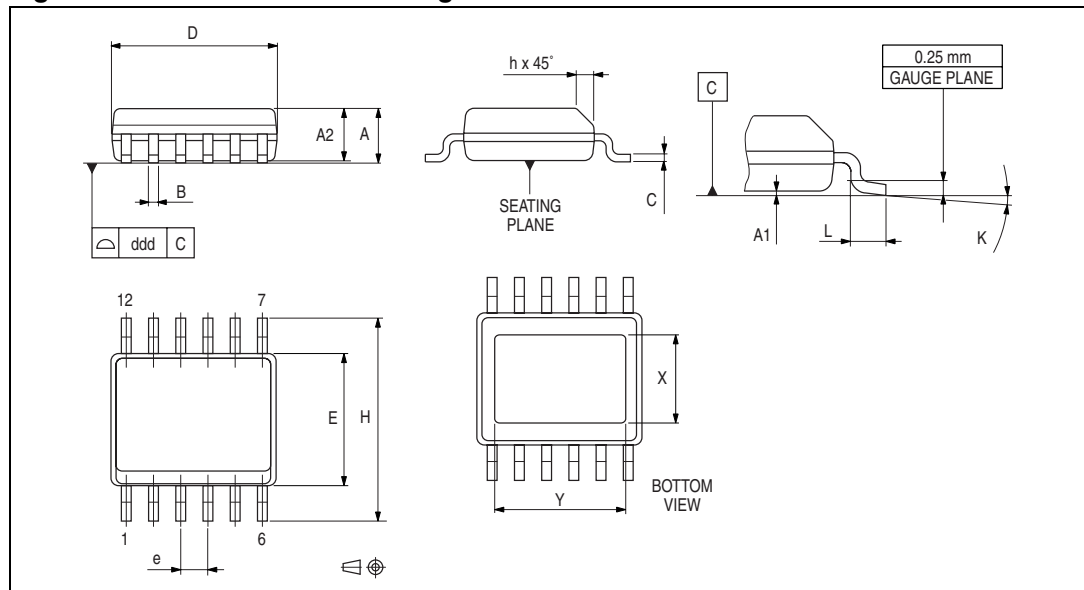

Table 12. PowerSSO-12™ Mechanical Data

Symbol	millimeters		
	Min	Typ	Max
A	1.250		1.620
A1	0.000		0.100
A2	1.100		1.650
B	0.230		0.410
C	0.190		0.250
D	4.800		5.000
E	3.800		4.000
e		0.800	
H	5.800		6.200
h	0.250		0.500
L	0.400		1.270
k	0°		8°
X	1.900		2.500
Y	3.600		4.200
ddd			0.100

Figure 39. PowerSSO-24™ Package Dimensions

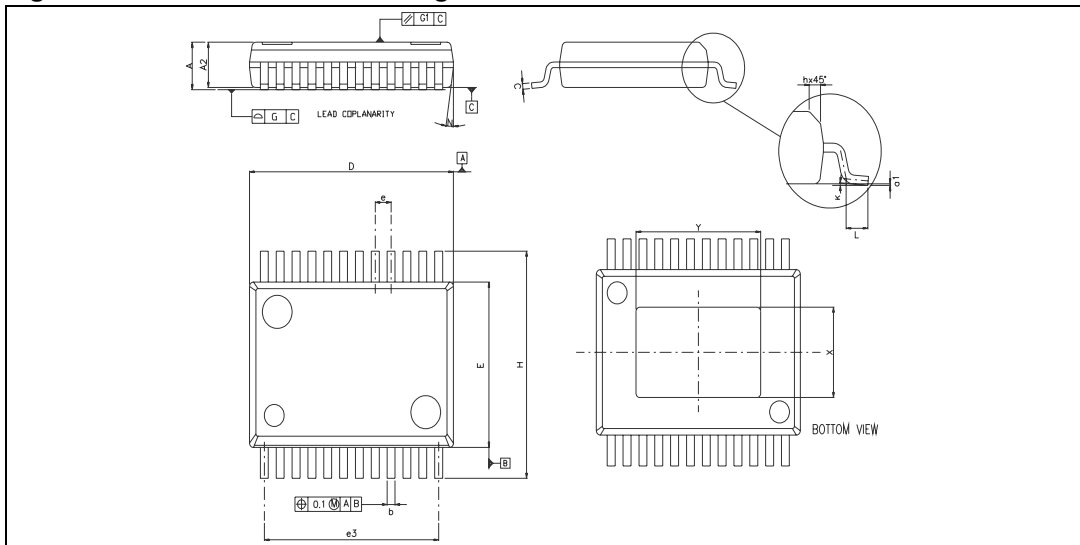

Table 13. PowerSSO-24™ Mechanical Data

Symbol	millimeters		
	Min	Typ	Max
A	2.15		2.47
A2	2.15		2.40
a1	0		0.075
b	0.33		0.51
c	0.23		0.32
D	10.10		10.50
E	7.4		7.6
e		0.8	
e3		8.8	
G			0.1
G1			0.06
H	10.1		10.5
h			0.4
L	0.55		0.85
N			10deg
X	4.1		4.7
Y	6.5		7.1

5.2 Packing information

Figure 40. PowerSSO-12 Tube Shipment (No Suffix)

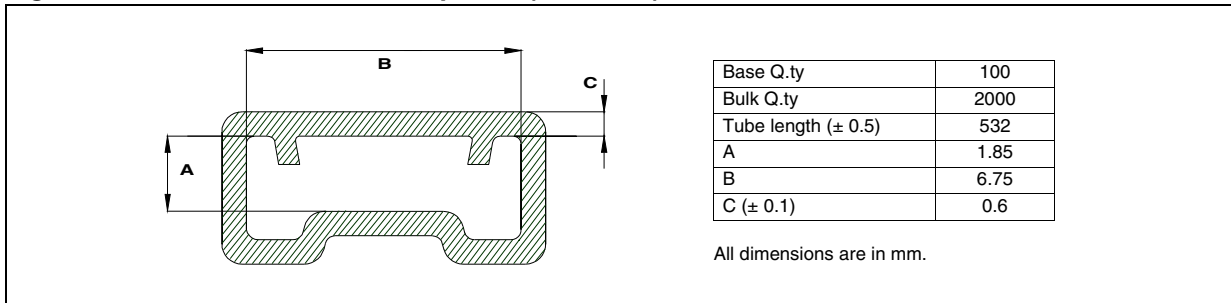

Figure 41. PowerSSO-12 Tape And Reel Shipment (Suffix "TR")

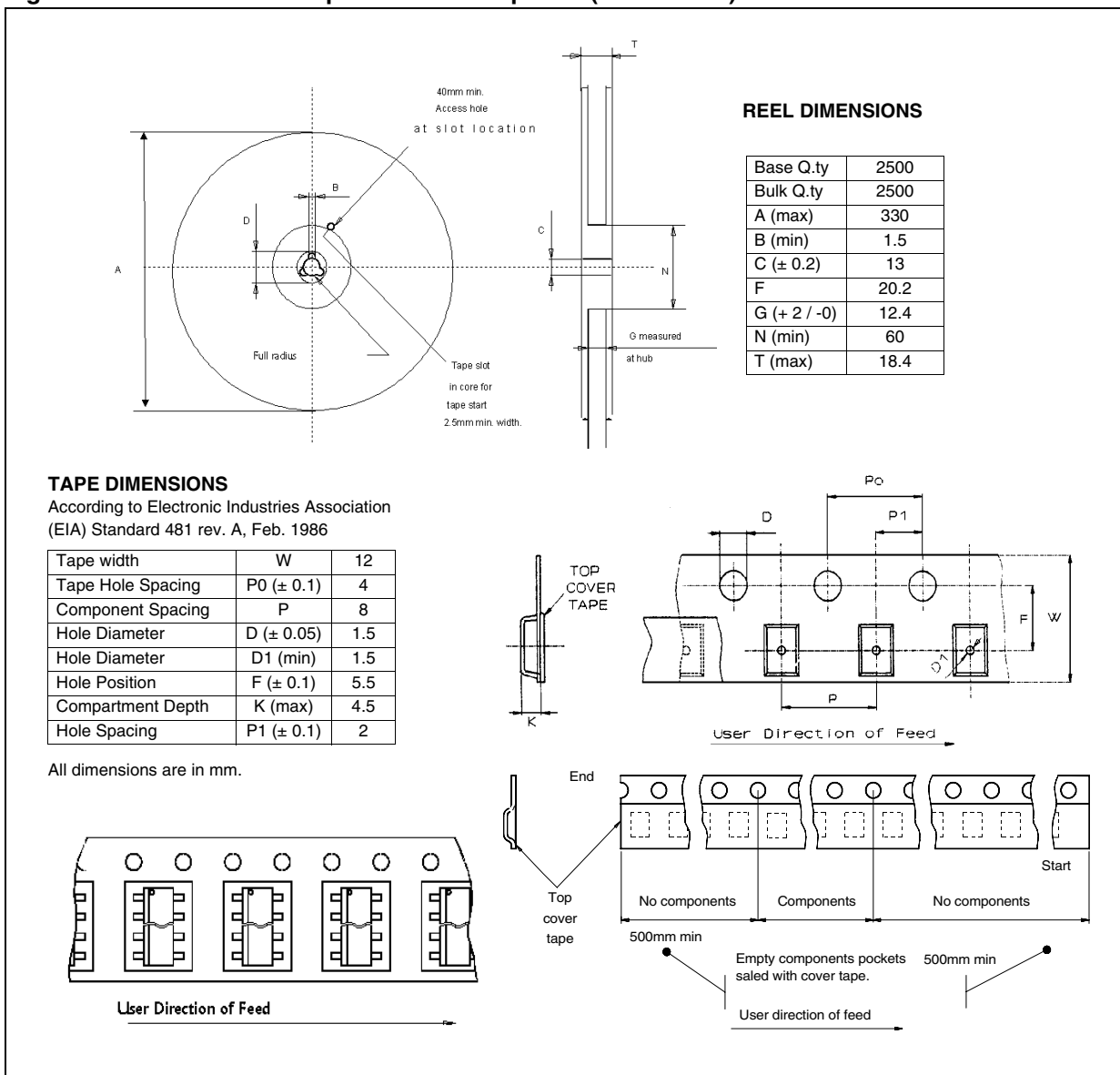

Figure 42. PowerSSO-24 Tube Shipment (No Suffix)

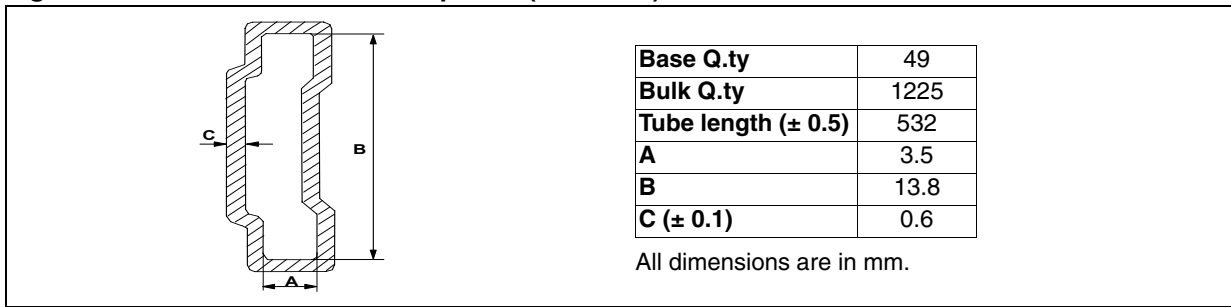
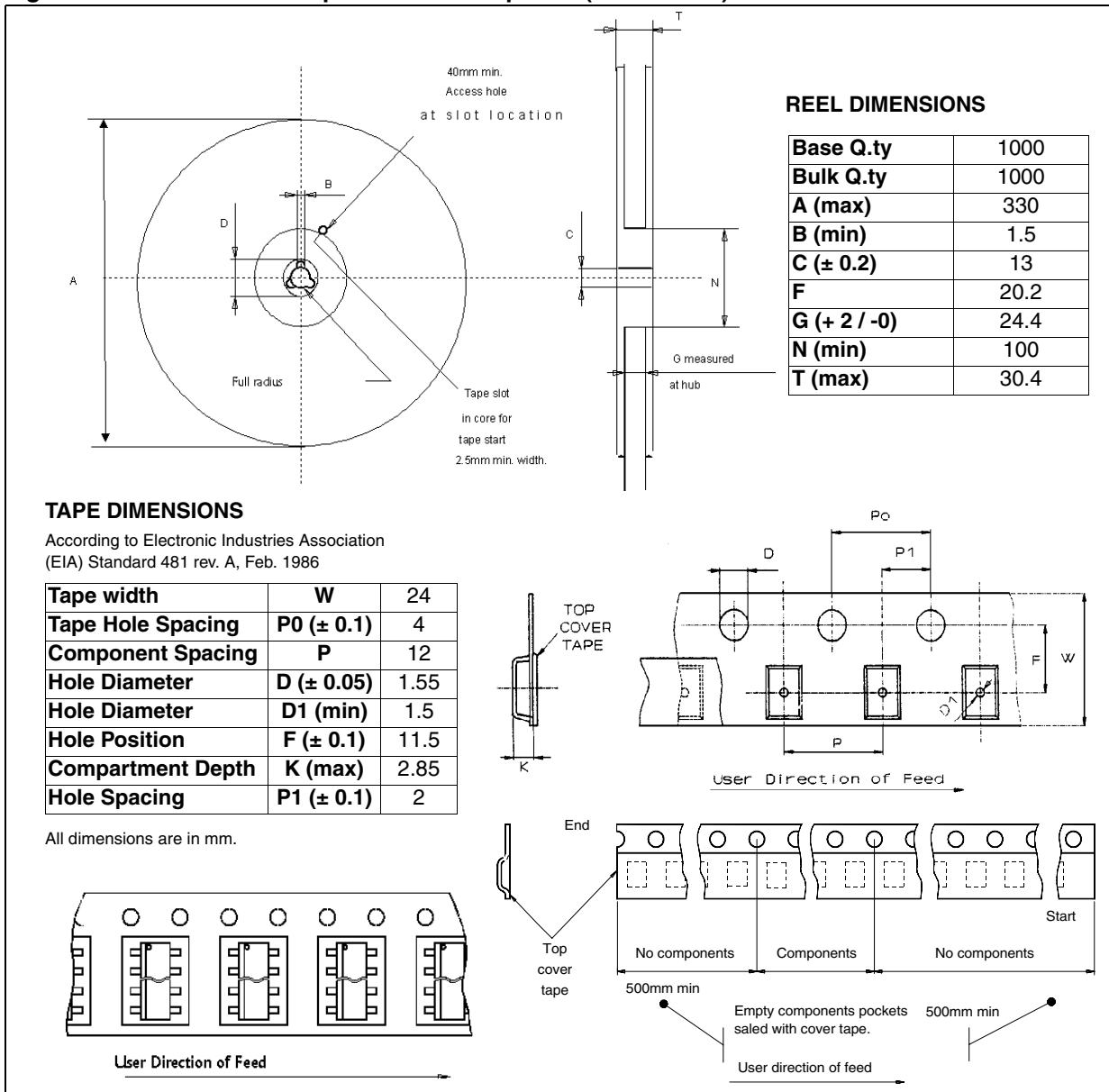

Figure 43. PowerSSO-24 Tape And Reel Shipment (Suffix "TR")



6 Revision history

Table 14. Document revision history

Date	Revision	Changes
30-Mar-2006	1	Initial release.

Please Read Carefully:

Information in this document is provided solely in connection with ST products. STMicroelectronics NV and its subsidiaries ("ST") reserve the right to make changes, corrections, modifications or improvements, to this document, and the products and services described herein at any time, without notice.

All ST products are sold pursuant to ST's terms and conditions of sale.

Purchasers are solely responsible for the choice, selection and use of the ST products and services described herein, and ST assumes no liability whatsoever relating to the choice, selection or use of the ST products and services described herein.

No license, express or implied, by estoppel or otherwise, to any intellectual property rights is granted under this document. If any part of this document refers to any third party products or services it shall not be deemed a license grant by ST for the use of such third party products or services, or any intellectual property contained therein or considered as a warranty covering the use in any manner whatsoever of such third party products or services or any intellectual property contained therein.

UNLESS OTHERWISE SET FORTH IN ST'S TERMS AND CONDITIONS OF SALE ST DISCLAIMS ANY EXPRESS OR IMPLIED WARRANTY WITH RESPECT TO THE USE AND/OR SALE OF ST PRODUCTS INCLUDING WITHOUT LIMITATION IMPLIED WARRANTIES OF MERCHANTABILITY, FITNESS FOR A PARTICULAR PURPOSE (AND THEIR EQUIVALENTS UNDER THE LAWS OF ANY JURISDICTION), OR INFRINGEMENT OF ANY PATENT, COPYRIGHT OR OTHER INTELLECTUAL PROPERTY RIGHT.

UNLESS EXPRESSLY APPROVED IN WRITING BY AN AUTHORIZE REPRESENTATIVE OF ST, ST PRODUCTS ARE NOT DESIGNED, AUTHORIZED OR WARRANTED FOR USE IN MILITARY, AIR CRAFT, SPACE, LIFE SAVING, OR LIFE SUSTAINING APPLICATIONS, NOR IN PRODUCTS OR SYSTEMS, WHERE FAILURE OR MALFUNCTION MAY RESULT IN PERSONAL INJURY, DEATH, OR SEVERE PROPERTY OR ENVIRONMENTAL DAMAGE.

Resale of ST products with provisions different from the statements and/or technical features set forth in this document shall immediately void any warranty granted by ST for the ST product or service described herein and shall not create or extend in any manner whatsoever, any liability of ST.

ST and the ST logo are trademarks or registered trademarks of ST in various countries.

Information in this document supersedes and replaces all information previously supplied.

The ST logo is a registered trademark of STMicroelectronics. All other names are the property of their respective owners.

© 2006 STMicroelectronics - All rights reserved

STMicroelectronics group of companies

Australia - Belgium - Brazil - Canada - China - Czech Republic - Finland - France - Germany - Hong Kong - India - Israel - Italy - Japan - Malaysia - Malta - Morocco - Singapore - Spain - Sweden - Switzerland - United Kingdom - United States of America

www.st.com