



**MMBTA44/45**

**NPN SILICON TRANSISTOR**

**HIGH VOLTAGE TRANSISTORS**

■ **FEATURES**

- \*Collector-Emitter voltage:  $V_{CE0}=400V$  (UTC **MMBTA44**)  
 $V_{CE0}=350V$  (UTC **MMBTA45**)
- \*Collector current up to 300mA
- \*Complement to UTC **MMBTA94/93**
- \*Power Dissipation:  $P_D(max)=350mW$

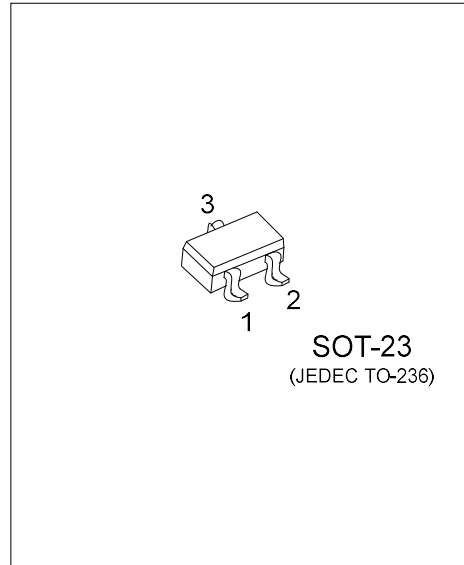

■ **ORDERING INFORMATION**

Ordering Number		Package	Pin Assignment			Packing
Lead Free	Halogen Free		1	2	3	
MMBTA44L-AE3-R	MMBTA44G-AE3-R	SOT-23	B	E	C	Tape Reel
MMBTA45L-AE3-R	MMBTA45G-AE3-R	SOT-23	B	E	C	Tape Reel

Note: Pin Assignment: B: Base E: Emitter C: Collector

<p>MMBTA44G-AE3-R</p>	<p>(1) Packing Type (1) R: Tape Reel</p> <p>(2) Package Type (2) AE3: SOT-23</p> <p>(3) Green Package (3) G: Halogen Free and Lead Free, L: Lead Free</p>
-----------------------	---

■ **MARKINGS**

MMBTA44	MMBTA45

## ■ ABSOLUTE MAXIMUM RATINGS

PARAMETER		SYMBOL	RATINGS	UNIT
Collector-Base Voltage	MMBTA44	$V_{CBO}$	500	V
	MMBTA45		400	V
Collector-Emitter Voltage	MMBTA44	$V_{CEO}$	400	V
	MMBTA45		350	V
Emitter-Base Voltage		$V_{EBO}$	6	V
Collector Current		$I_C$	300	mA
Power Dissipation (Note 2)	$T_A=25^{\circ}\text{C}$	$P_D$	350	mW
	$T_C=25^{\circ}\text{C}$		1.5	W
Junction Temperature		$T_J$	+150	$^{\circ}\text{C}$
Storage Temperature		$T_{STG}$	-40 ~ +150	$^{\circ}\text{C}$

Notes: 1. Absolute maximum ratings are those values beyond which the device could be permanently damaged. Absolute maximum ratings are stress ratings only and functional device operation is not implied.  
 2. Device mounted on FR-4 substrate PC board, 2oz copper, with 1inch square copper plate.

## ■ ELECTRICAL CHARACTERISTICS ( $T_J=25^{\circ}\text{C}$ , unless otherwise specified)

PARAMETER		SYMBOL	TEST CONDITIONS	MIN	TYP	MAX	UNIT
Collector-Base Breakdown Voltage	MMBTA44	$BV_{CBO}$	$I_C=100\mu\text{A}, I_B=0$	500			V
	MMBTA45			400			V
Collector-Emitter Breakdown Voltage	MMBTA44	$BV_{CEO}$	$I_C=1\text{mA}, I_B=0$	400			V
	MMBTA45			350			V
Emitter-Base Breakdown Voltage		$BV_{EBO}$	$I_E=100\mu\text{A}, I_C=0$	6			V
Collector-Emitter Saturation Voltage		$V_{CE(SAT)}$	$I_C=1\text{mA}, I_B=0.1\text{mA}$			0.4	V
			$I_C=10\text{mA}, I_B=1\text{mA}$			0.5	V
			$I_C=50\text{mA}, I_B=5\text{mA}$			0.75	V
Base-Emitter Saturation Voltage		$V_{BE(SAT)}$	$I_C=10\text{mA}, I_B=1\text{mA}$			0.75	V
Collector Cut-off Current	MMBTA44	$I_{CBO}$	$V_{CB}=400\text{V}, I_E=0$			0.1	$\mu\text{A}$
	MMBTA45		$V_{CB}=320\text{V}, I_E=0$			0.1	$\mu\text{A}$
Collector Cut-off Current	MMBTA44	$I_{CES}$	$V_{CE}=400\text{V}, I_B=0$			0.5	$\mu\text{A}$
	MMBTA45		$V_{CE}=320\text{V}, I_B=0$			0.5	$\mu\text{A}$
Emitter Cut-off Current		$I_{EBO}$	$V_{EB}=4\text{V}, I_C=0$			0.1	$\mu\text{A}$
DC Current Gain (Note)		$h_{FE1}$	$V_{CE}=10\text{V}, I_C=1\text{mA}$	40			
			$V_{CE}=10\text{V}, I_C=10\text{mA}$	50		240	
			$V_{CE}=10\text{V}, I_C=50\text{mA}$	45			
			$V_{CE}=10\text{V}, I_C=100\text{mA}$	40			
Current Gain Bandwidth Product		$f_T$	$V_{CE}=20\text{V}, I_C=10\text{mA}$ $f=100\text{MHz}$	50			MHz
Output Capacitance		$C_{ob}$	$V_{CB}=20\text{V}, I_E=0, f=1\text{MHz}$			7	pF

Note: Pulse test: Pulse Width  $\leq 300\mu\text{s}$ , Duty Cycle  $\leq 2\%$ .

## ■ TYPICAL CHARACTERISTICS

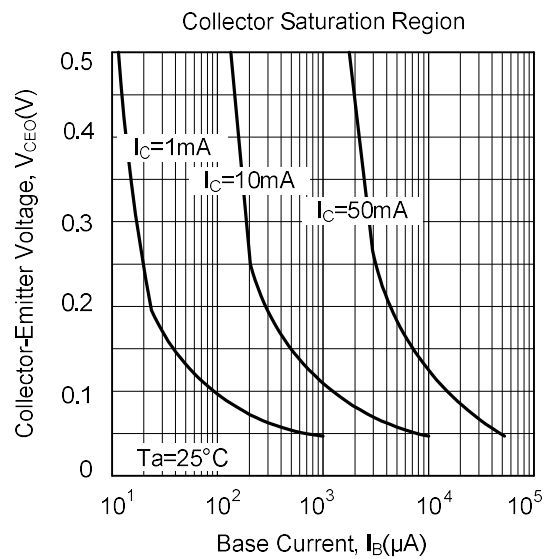
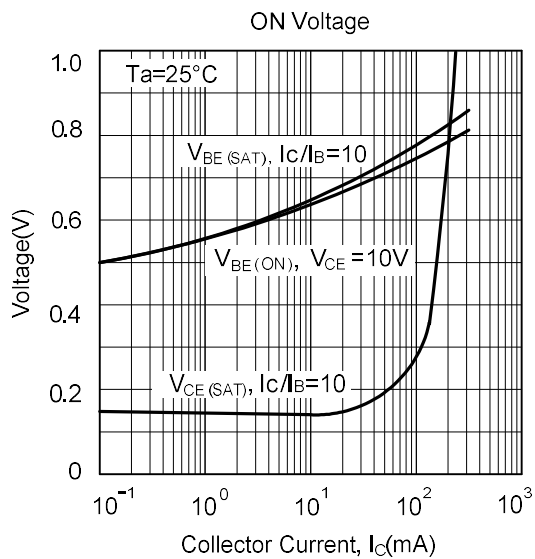
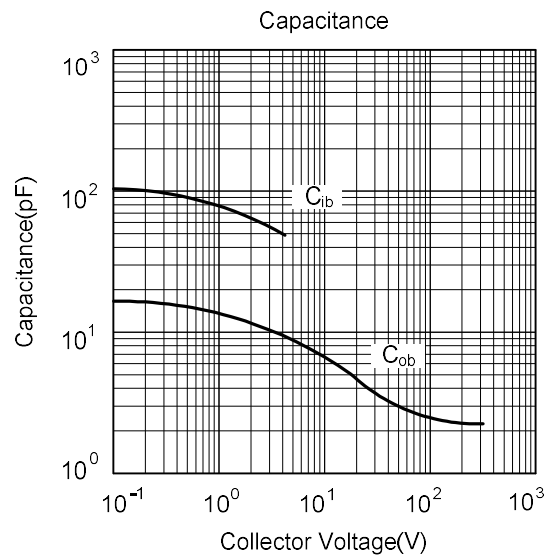
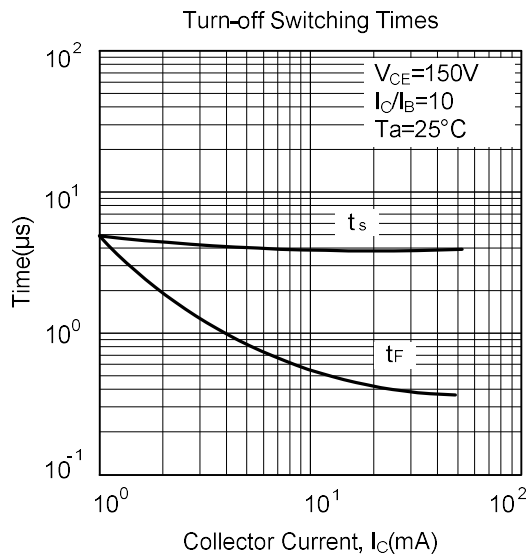
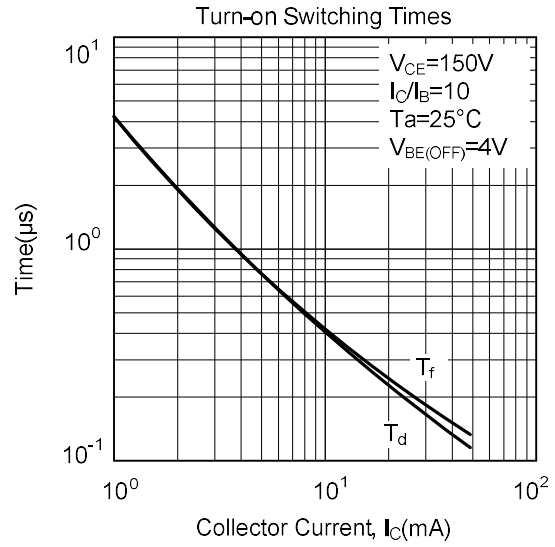
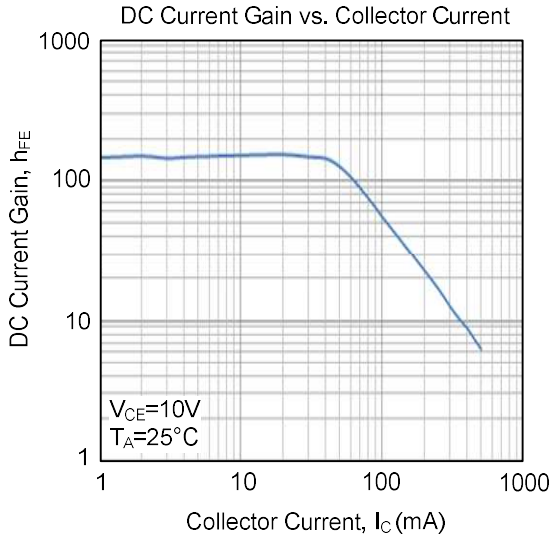

## ■ TYPICAL CHARACTERISTICS (Cont.)

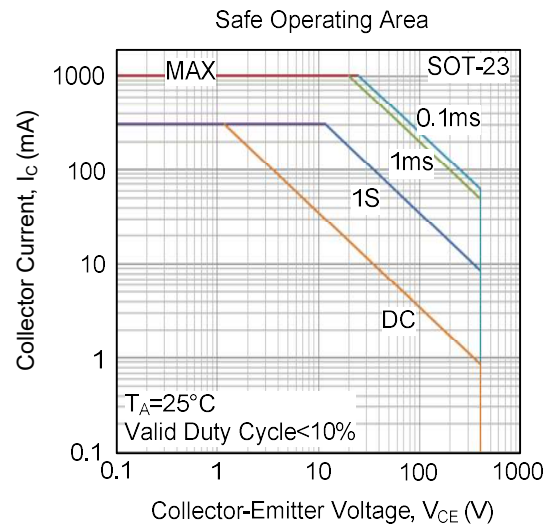
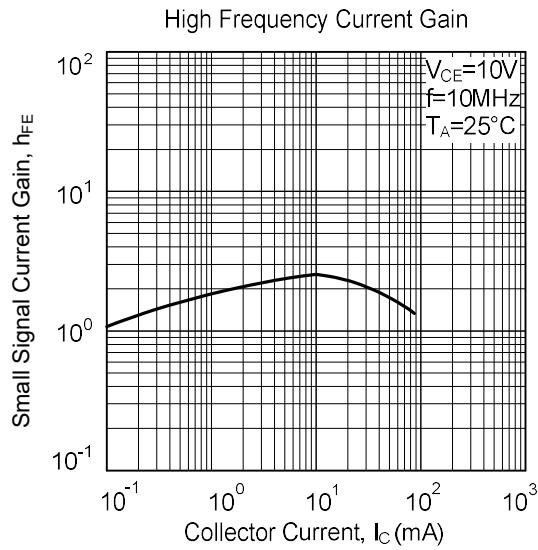

UTC assumes no responsibility for equipment failures that result from using products at values that exceed, even momentarily, rated values (such as maximum ratings, operating condition ranges, or other parameters) listed in products specifications of any and all UTC products described or contained herein. UTC products are not designed for use in life support appliances, devices or systems where malfunction of these products can be reasonably expected to result in personal injury. Reproduction in whole or in part is prohibited without the prior written consent of the copyright owner. UTC reserves the right to make changes to information published in this document, including without limitation specifications and product descriptions, at any time and without notice. This document supersedes and replaces all information supplied prior to the publication hereof.