

**Low Noise CATV Amplifier
50 - 870 MHz**

**MAAMSS0040
V1**

Features

- Low Noise Figure
- Low Distortion
- Surface Mount Package
- Push-Pull Design Application
- Single Positive Supply
- Lead Free SOIC-16 Package
- 100% Matte Tin Plating
- Halogen-Free “Green” Mold Compound
- 260°C Re-flow Compatible
- Lead Free Version of MAAMSS0001

Description

M/A-COM's MAAMSS0040 is a GaAs PHEMT MMIC amplifier in a lead-free surface mount SOIC-16 package. The MMIC design is configured as a pair of cascode PHEMT amplifiers for broadband performance. It is designed for integration in a 75-ohm push-pull low distortion amplifier circuit. The device is ideally suited for use in CATV, DBS, and DTV applications where low noise figure, low distortion and high linearity are required.

Functional Schematic

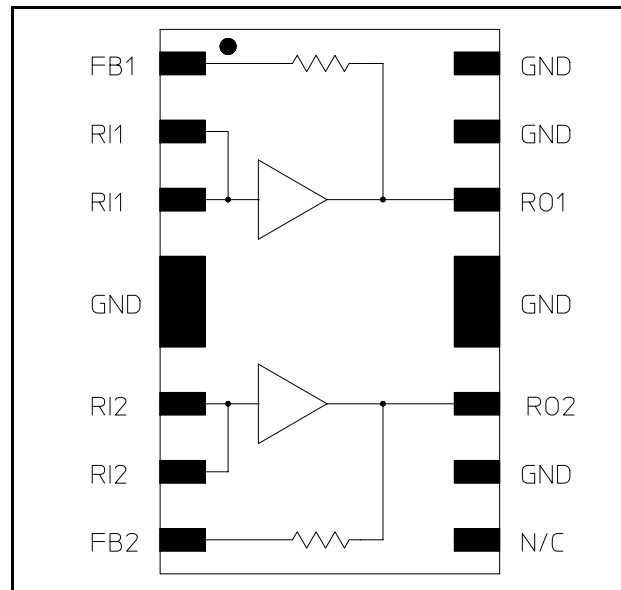

Pin Configuration

PIN No.	PIN Name	Description
1	FB1	Feedback 1
2	RI1	RF Input 1
3	RI1	RF Input 1
4	GND	Ground
5	GND	Ground
6	RI2	RF Input 2
7	RI2	RF Input 2
8	FB2	Feedback 2
9	N/C	No Connection
10	GND	Ground
11	RO2	RF Output 2
12	GND	Ground
13	GND	Ground
14	RO1	RF Output 1
15	GND	Ground
16	GND	Ground

Ordering Information

Part Number	Package
MAAMSS0040	Bulk Packaging
MAAMSS0040TR	1000 piece reel
MAAMSS0040SMB	Sample Test Board (Includes 5 Samples)

Note: Reference Application Note M513 for reel size information.

Absolute Maximum Ratings ¹

Parameter	Absolute Maximum
Input Power	+20 dBm
Operating Voltage	+10 volts
Operating Temperature	-40°C to +85°C
Storage Temperature	-65°C to +150°C

1. Exceeding any one or combination of these limits may cause permanent damage to this device.

Typical Performance Curves

Gain vs. Frequency over Temperature

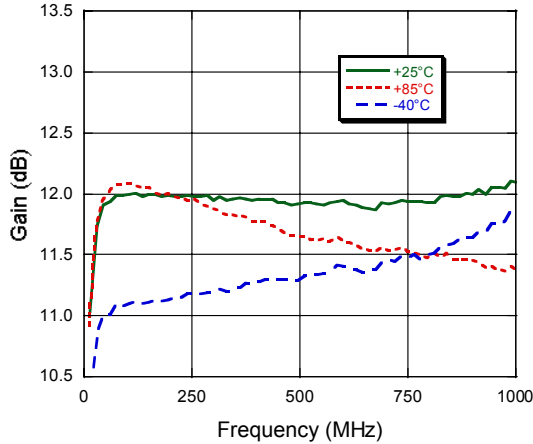

Gain vs. Frequency to 3 GHz over Temperature

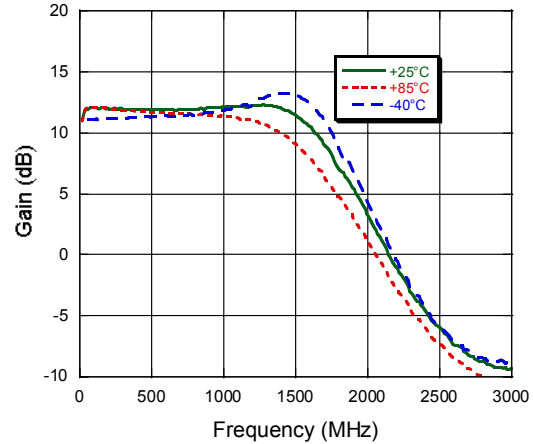

Input Return Loss vs. Frequency over Temperature

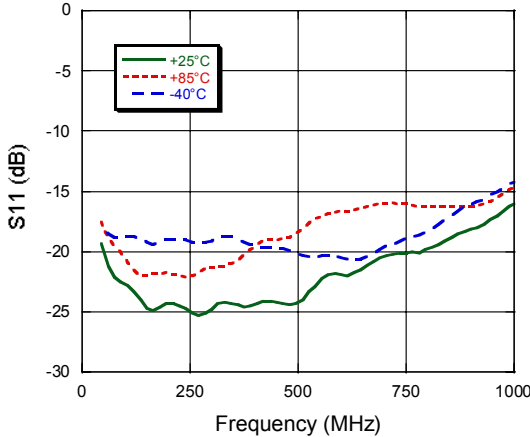

Output Return Loss vs. Frequency over Temperature

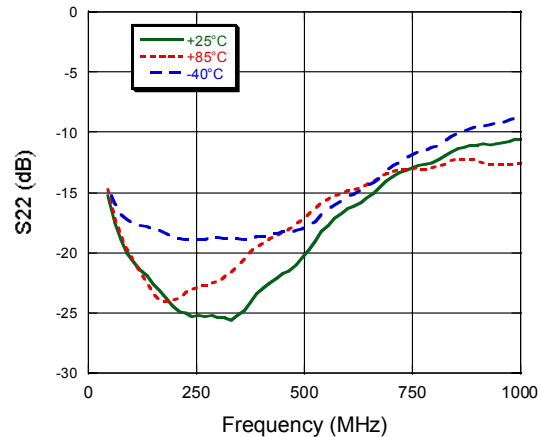

OIP3 vs. P_{IN} at 400 MHz, 25°C

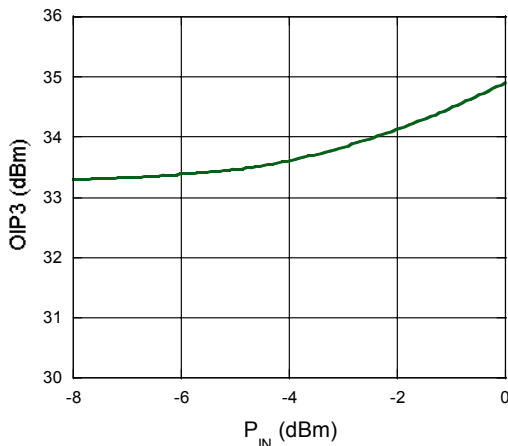

Noise Figure vs. Frequency, 25°C

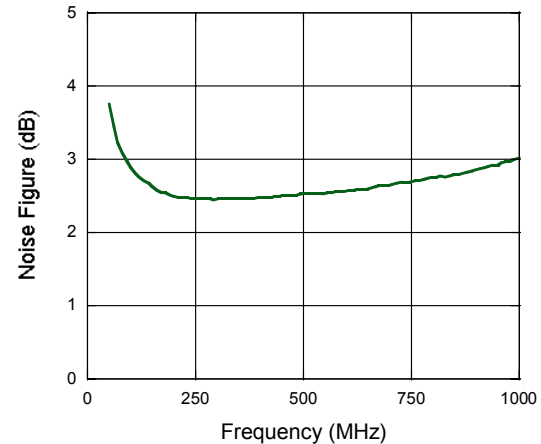

**Low Noise CATV Amplifier
50 - 870 MHz**

**MAAMSS0040
V1**

Typical Performance Curves

Gain vs P_{OUT} at 400 MHz vs. Temperature

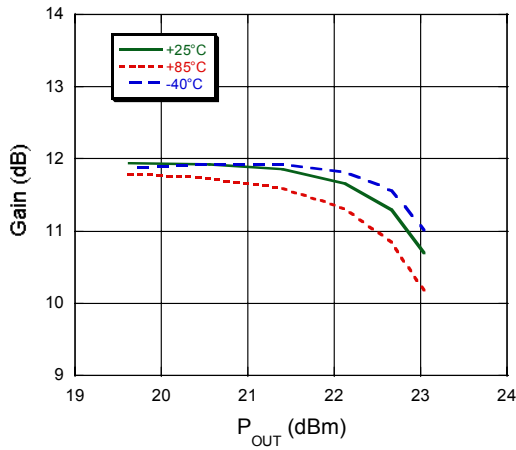

**Recommended PCB Configuration with
0.031" thick FR4**

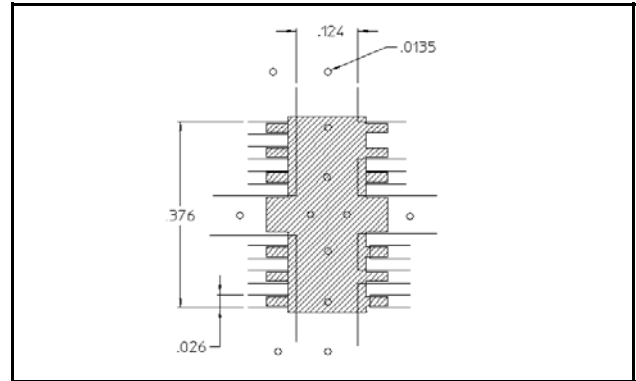

Recommended Test Circuit Layout

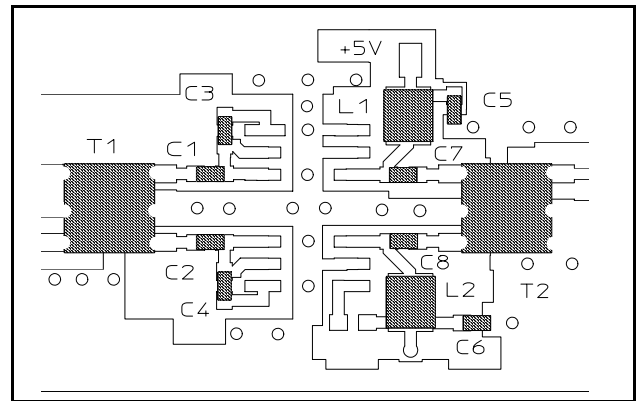

External Circuitry Parts List

Qty	Description	
8	Capacitor, 0.01 μF, 0603, SMT, 10%	(C1-C8)
2	Inductor, 390 nH, 1008, SMT, 10%	(L1, L2)
2	Balun, 1:1, M/A-COM, ETN1-1-13TR, SMT	(T1, T2)

Test Circuit Schematic

