



## 1. GENERAL DESCRIPTION

The W79E648 is a fast 8051 compatible microcontroller with a redesigned processor core without wasted clock and memory cycles. As a result, it executes every 8051 instruction faster than the original 8051 for the same crystal speed. Typically, the instruction executing time of W79E648 is 1.5 to 3 times faster than that of traditional 8051, depending on the type of instruction. In general, the overall performance is about 2.5 times better than the original for the same crystal speed. Giving the same throughput with lower clock speed, power consumption has been improved. Consequently, the W79E648 is a fully static CMOS design; it can also be operated at a lower crystal clock. The W79E648 contains In-System Programmable (ISP) 128 KB bank-addressed Flash EPROM; 4KB auxiliary Flash EPROM for loader program; on-chip 1 KB MOVX SRAM; power saving modes.

## 2. FEATURES

- 8-bit CMOS microcontroller
- High speed architecture of 4 clocks/machine cycle runs up to 40 MHz
- Instruction-set compatible with MCS-51
- Seven 8-bit I/O Ports
- One extra 4-bit I/O ports, chip select, reboot fuction
- Three 16-bit Timers
- 7 interrupt sources with two levels of priority
- On-chip oscillator and clock circuitry
- One enhanced full duplex serial port
- Dual 64KB In-System Programmable Flash EPROM banks (AP Flash EPROM 0 and AP Flash EPROM 1)
- 4KB Auxiliary Flash EPROM for loader program (LD Flash EPROM)
- 256 bytes scratch-pad RAM
- 1 KB on-chip SRAM for MOVX instruction
- Programmable Watchdog Timer
- 6 channels of 8 bit PWM
- Software Reset
- Software programmable access cycle to external RAM/peripherals
- Code protection
- Packages:
  - PLCC 68: W79E648X40PX

# Preliminary W79E648



## PIN CONFIGURATION

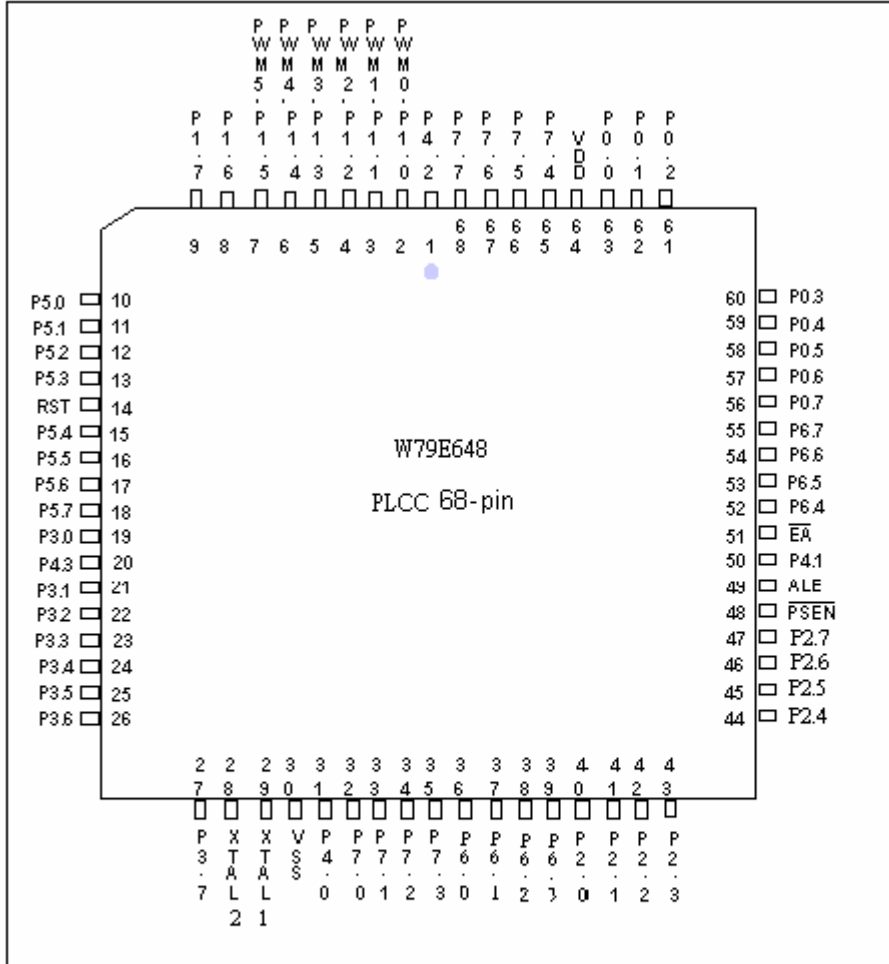



### 3. PIN DESCRIPTION

SYMBOL	TYPE	DESCRIPTIONS
$\overline{EA}$	I	<b>EXTERNAL ACCESS ENABLE:</b> This pin forces the processor to execute out of external ROM. It should be kept high to access internal ROM. The ROM address and data will not be present on the bus if $\overline{EA}$ pin is high and the program counter is within 128 KB area. Otherwise they will be present on the bus.
$\overline{PSEN}$	O	<b>PROGRAM STORE ENABLE:</b> $\overline{PSEN}$ enables the external ROM data onto the Port 0 address/data bus during fetch and MOVC operations. When internal ROM access is performed, no $\overline{PSEN}$ strobe signal outputs from this pin.
ALE	O	<b>ADDRESS LATCH ENABLE:</b> ALE is used to enable the address latch that separates the address from the data on Port 0.
RST	I	<b>RESET:</b> A high on this pin for two machine cycles while the oscillator is running resets the device.
XTAL1	I	<b>CRYSTAL1:</b> This is the crystal oscillator input. This pin may be driven by an external clock.
XTAL2	O	<b>CRYSTAL2:</b> This is the crystal oscillator output. It is the inversion of XTAL1.
Vss	I	<b>GROUND:</b> Ground potential
VDD	I	<b>POWER SUPPLY:</b> Supply voltage for operation.
P0.0 – P0.7	I/O	<b>PORT 0:</b> Port 0 is an open-drain bi-directional I/O port. This port also provides a multiplexed low order address/data bus during accesses to external memory.
P1.0 – P1.7	I/O	<b>PORT 1:</b> Port 1 is a bi-directional I/O port with internal pull-ups. The bits have alternate functions which are described below: T2(P1.0): Timer/Counter 2 external count input T2EX(P1.1): Timer/Counter 2 Reload/Capture/Direction control
P2.0 – P2.7	I/O	<b>PORT 2:</b> Port 2 is a bi-directional I/O port with internal pull-ups. This port also provides the upper address bits for accesses to external memory.

# Preliminary W79E648



Pin Description, continued

SYMBOL	TYPE	DESCRIPTIONS
P3.0 – P3.7	I/O	<p><b>PORT 3:</b> Port 3 is a bi-directional I/O port with internal pull-ups. All bits have alternate functions, which are described below:</p> <p>RXD(P3.0) : Serial Port 0 input</p> <p>TXD(P3.1) : Serial Port 0 output</p> <p><math>\overline{\text{INT0}}</math> (P3.2) : External Interrupt 0</p> <p><math>\overline{\text{INT1}}</math> (P3.3) : External Interrupt 1</p> <p>T0(P3.4) : Timer 0 External Input</p> <p>T1(P3.5) : Timer 1 External Input</p> <p><math>\overline{\text{WR}}</math> (P3.6) : External Data Memory Write Strobe</p> <p><math>\overline{\text{RD}}</math> (P3.7) : External Data Memory Read Strobe</p>
P4.0 – P4.3	I/O	<p><b>PORT 4:</b> Port 4 is a 4-bit bi-directional I/O port. The P4.3 also provide the alternate function <math>\overline{\text{REBOOT}}</math> which is H/W reboot from LD flash.</p>
P5.0 – P5.7	I/O	<p><b>PORT 5:</b> Port 5 is a bi-directional I/O port with internal pull-ups.</p>
P6.0 – P6.7	I/O	<p><b>PORT6:</b> Port 6 is a bi-directional I/O port with internal pull-ups.</p>
P7.0 – P7.7	I/O	<p><b>PORT 7:</b> Port 7 is a bi-directional I/O port with internal pull-ups.</p>

\* Note: **TYPE** I : input, O: output, I/O: bi-directional.

# Preliminary W79E648



## 4. BLOCK DIAGRAM

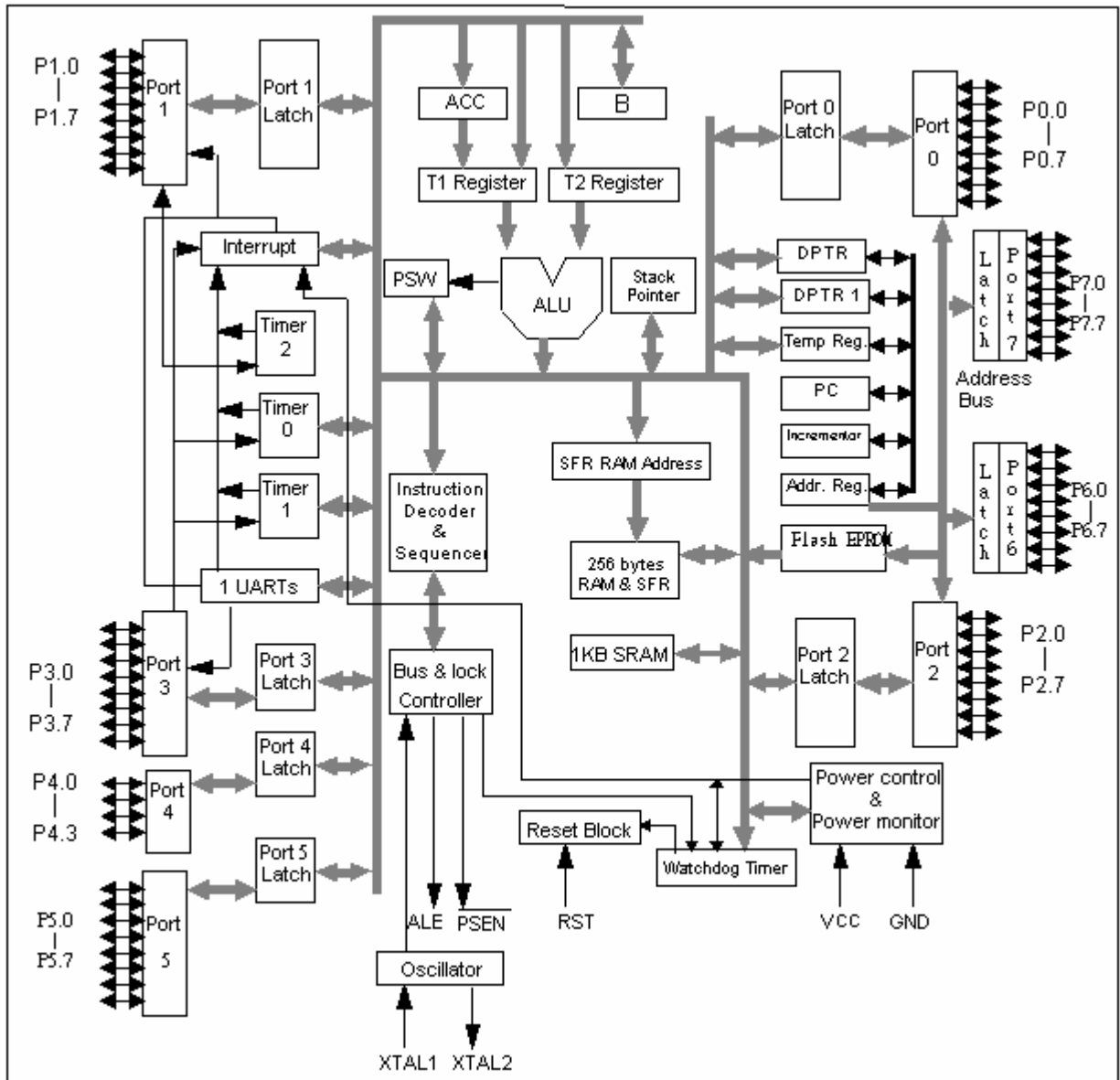

5.



## FUNCTIONAL DESCRIPTION

The W79E648 is 8052 pin compatible and instruction set compatible. It includes the resources of the standard 8052 such as four 8-bit I/O Ports, three 16-bit timer/counters, full duplex serial port and interrupt sources.

The W79E648 features a faster running and better performance 8-bit CPU with a redesigned core processor without wasted clock and memory cycles. It improves the performance not just by running at high frequency but also by reducing the machine cycle duration from the standard 8052 period of twelve clocks to four clock cycles for the majority of instructions. This improves performance by an average of 1.5 to 3 times. It can also adjust the duration of the MOVX instruction (access to off-chip data memory) between two machine cycles and nine machine cycles. This flexibility allows the W79E648 to work efficiently with both fast and slow RAMs and peripheral devices. In addition, the W79E648 contains on-chip 1KB MOVX SRAM, the address of which is between 0000H and 03FFH. It only can be accessed by MOVX instruction; this on-chip SRAM is optional under software control.

The W79E648 is an 8052 compatible device that gives the user the features of the original 8052 device, but with improved speed and power consumption characteristics. It has the same instruction set as the 8051 family. While the original 8051 family was designed to operate at 12 clock periods per machine cycle, the W79E648 operates at a much reduced clock rate of only 4 clock periods per machine cycle. This naturally speeds up the execution of instructions. Consequently, the W79E648 can run at a higher speed as compared to the original 8052, even if the same crystal is used. Since the W79E648 is a fully static CMOS design, it can also be operated at a lower crystal clock, giving the same throughput in terms of instruction execution, yet reducing the power consumption.

The 4 clocks per machine cycle feature in the W79E648 is responsible for a three-fold increase in execution speed. The W79E648 has all the standard features of the 8052, and has a few extra peripherals and features as well.

### I/O Ports

The W79E648 has four 8-bit ports and one extra 4-bit port. Port 0 can be used as an Address/Data bus when external program is running or external memory/device is accessed by MOVC or MOVX instruction. In these cases, it has strong pull-ups and pull-downs, and does not need any external pull-ups. Otherwise it can be used as a general I/O port with open-drain circuit. Port 2 is used chiefly as the upper 8-bits of the Address bus when port 0 is used as an address/data bus. It also has strong pull-ups and pull-downs when it serves as an address bus. Port 1 and 3 act as I/O ports with alternate functions. Port 4 serves as a general purpose I/O port as Port 1 and Port 3.

### Serial I/O

The W79E648 has one enhanced serial ports that are functionally similar to the serial port of the original 8052 family. However the serial ports on the W79E648 can operate in different modes in order to obtain timing similarity as well. The serial port has the enhanced features of Automatic Address recognition and Frame Error detection.



## Timers

The W79E648 has three 16-bit timers that are functionally similar to the timers of the 8052 family. When used as timers, they can be set to run at either 4 clocks or 12 clocks per count, thus providing the user with the option of operating in a mode that emulates the timing of the original 8052. The W79E648 has an additional feature, the watchdog timer. This timer is used as a System Monitor or as a very long time period timer.

## Interrupts

The Interrupt structure in the W79E648 is slightly different from that of the standard 8052. Due to the presence of additional features and peripherals, the number of interrupt sources and vectors has been increased. The W79E648 provides 7 interrupt resources with two priority level, including 2 external interrupt sources, timer interrupts, serial I/O interrupts.

## Power Management

Like the standard 80C52, the W79E648 also has IDLE and POWER DOWN modes of operation. The W79E648 provides a new Economy mode which allow user to switch the internal clock rate divided by either 4, 64 or 1024. In the IDLE mode, the clock to the CPU core is stopped while the timers, serial port and interrupts clock continue to operate. In the POWER DOWN mode, all the clock are stopped and the chip operation is completely stopped. This is the lowest power consumption state.

## On-chip Data SRAM

The W79E648 has 1K Bytes of data space SRAM which is read/write accessible and is memory mapped. This on-chip MOVX SRAM is reached by the MOVX instruction. It is not used for executable program memory. There is no conflict or overlap among the 256 bytes Scratchpad RAM and the 1K Bytes MOVX SRAM as they use different addressing modes and separate instructions. The on-chip MOVX SRAM is enabled by setting the DME0 bit in the PMR register. After a reset, the DME0 bit is cleared such that the on-chip MOVX SRAM is disabled, and all data memory spaces 0000H – FFFFH access to the external memory.

## 6. MEMORY ORGANIZATION

The W79E648 separates the memory into two separate sections, the Program Memory and the Data Memory. The Program Memory is used to store the instruction op-codes, while the Data Memory is used to store data or for memory mapped devices.

### Program Memory

The Program Memory on the standard 8052 can only be addressed to 64 Kbytes long. By invoking the banking methodology, W79E648 can extend to two 64KB flash EPROM banks, APFlash0 and APFlash1. There are on-chip ROM banks which can be used similarly to that of the 8052. All instructions are fetched for execution from this memory area. The MOVC instruction can also access this memory region. There is an auxiliary 4KB Flash EPROM bank (LDFlash) resided user loader program for In-System Programming (ISP). Both APFlashes allow serial or parallel download according to user loader program in LDFlash.

### Data Memory

The W79E648 can access up to 64Kbytes of external Data Memory. This memory region is accessed by the MOVX instructions. Unlike the 8051 derivatives, the W79E648 contains on-chip 1K bytes MOVX SRAM of Data Memory, which can only be accessed by MOVX instructions. These 1K bytes of SRAM are between address 0000H and 03FFFH. Access to the on-chip MOVX SRAM is optional under

# Preliminary W79E648



software control. When enabled by software, any MOVX instruction that uses this area will go to the on-chip RAM. MOVX addresses greater than 03FFH automatically go to external memory through Port 0 and 2. When disabled, the 1KB memory area is transparent to the system memory map. Any MOVX directed to the space between 0000H and FFFFH goes to the expanded bus on Port 0 and 2. This is the default condition. In addition, the W79E648 has the standard 256 bytes of on-chip Scratchpad RAM. This can be accessed either by direct addressing or by indirect addressing. There are also some Special Function Registers (SFRs), which can only be accessed by direct addressing. Since the Scratchpad RAM is only 256 bytes, it can be used only when data contents are small. In the event that larger data contents are present, two selections can be used. One is on-chip MOVX SRAM, the other is the external Data Memory. The on-chip MOVX SRAM can only be accessed by a MOVX instruction, the same as that for external Data Memory. However, the on-chip RAM has the fastest access times.

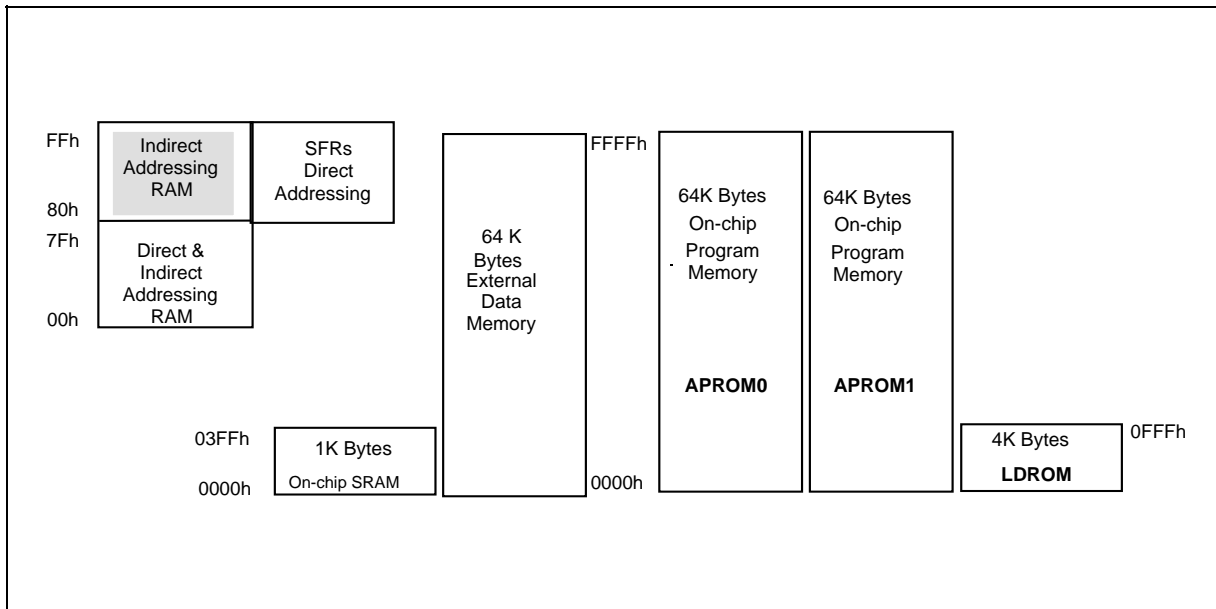

Figure 1. Memory Map



## Special Function Registers

The W79E648 uses Special Function Registers (SFRs) to control and monitor peripherals and their Modes.

The SFRs reside in the register locations 80-FFh and are accessed by direct addressing only. Some of the SFRs are bit addressable. This is very useful in cases where one wishes to modify a particular bit without changing the others. The SFRs that are bit addressable are those whose addresses end in 0 or 8. The W79E648 contains all the SFRs present in the standard 8052. However, some additional SFRs have been added. In some cases unused bits in the original 8052 have been given new functions. The list of SFRs is as follows. The table is condensed with eight locations per row. Empty locations indicate that there are no registers at these addresses. When a bit or register is not implemented, it will read high.

**Table 1. Special Function Register Location Table**

F8	EIP							
F0	B							
E8	EIE							
E0	ACC							
D8	WDCON	PWMP	PWM0	PWM1	PWMCON1	PWM2	PWM3	
D0	PSW							
C8	T2CON	T2MOD	RCAP2L	RCAP2H	TL2	TH2	PWMCON2	PWM4
C0				PWM5	PMR	STATUS		TA
B8	IP	SADEN						
B0	P3	P5	P6	P7				
A8	IE	SADDR		ROMCON	SFRAL	SFRAH	SFDFD	SFRCN
A0	P2	XRAMAH	P4CSIN			P4		
98	SCON0	SBUF	P42AL	P42AH	P43AL	P43AH		CHPCON
90	P1		P4CONA	P4CONB	P40AL	P40AH	P41AL	P41AH
88	TCON	TMOD	TL0	TL1	TH0	TH1	CKCON	
80	P0	SP	DPL	DPH				PCON

Note: The SFRs in the column with dark borders are bit-addressable.

# Preliminary W79E648



A brief description of the SFRs now follows.

## Port 0

Bit:	7	6	5	4	3	2	1	0
	P0.7	P0.6	P0.5	P0.4	P0.3	P0.2	P0.1	P0.0

Mnemonic: P0

Address: 80h

Port 0 is an open-drain bi-directional I/O port. This port also provides a multiplexed low order address/data bus during accesses to external memory.

## Stack Pointer

Bit:	7	6	5	4	3	2	1	0
	SP.7	SP.6	SP.5	SP.4	SP.3	SP.2	SP.1	SP.0

Mnemonic: SP

Address: 81h

The Stack Pointer stores the Scratchpad RAM address where the stack begins. In other words, it always points to the top of the stack.

## Data Pointer Low

Bit:	7	6	5	4	3	2	1	0
	DPL.7	DPL.6	DPL.5	DPL.4	DPL.3	DPL.2	DPL.1	DPL.0

Mnemonic: DPL

Address: 82h

This is the low byte of the standard 8052 16-bit data pointer.

## Data Pointer High

Bit:	7	6	5	4	3	2	1	0
	DPH.7	DPH.6	DPH.5	DPH.4	DPH.3	DPH.2	DPH.1	DPH.0

Mnemonic: DPH

Address: 83h

This is the high byte of the standard 8052 16-bit data pointer.

## Power Control

Bit:	7	6	5	4	3	2	1	0
	SMOD	SMOD0	-	-	GF1	GF0	PD	IDL

Mnemonic: PCON

Address: 87h

SMOD : This bit doubles the serial port baud rate in mode 1, 2, and 3 when set to 1.

SMOD0: Framing Error Detection Enable: When SMOD0 is set to 1, then SCON.7 indicates a Frame Error and acts as the FE flag. When SMOD0 is 0, then SCON.7 acts as per the standard 8052 function.

GF1-0: These two bits are general purpose user flags.

# Preliminary W79E648



- PD: Setting this bit causes the W79E648 to go into the POWER DOWN mode. In this mode all the clocks are stopped and program execution is frozen.
- IDL: Setting this bit causes the W79E648 to go into the IDLE mode. In this mode the clocks to the CPU are stopped, so program execution is frozen. But the clock to the serial, timer and interrupt blocks is not stopped, and these blocks continue operating.

## Timer Control

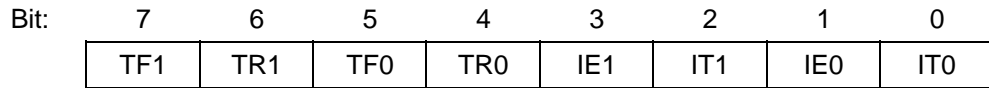

Mnemonic: TCON

Address: 88h

- TF1: Timer 1 overflow flag: This bit is set when Timer 1 overflows. It is cleared automatically when the program does a timer 1 interrupt service routine. Software can also set or clear this bit.
- TR1: Timer 1 run control: This bit is set or cleared by software to turn timer/counter on or off.
- TF0: Timer 0 overflow flag: This bit is set when Timer 0 overflows. It is cleared automatically when the program does a timer 0 interrupt service routine. Software can also set or clear this bit.
- TR0: Timer 0 run control: This bit is set or cleared by software to turn timer/counter on or off.
- IE1: Interrupt 1 edge detect: Set by hardware when an edge/level is detected on  $\overline{INT1}$ . This bit is cleared by hardware when the service routine is vectored to only if the interrupt was edge triggered. Otherwise it follows the pin.
- IT1: Interrupt 1 type control: Set/cleared by software to specify falling edge/ low level triggered external inputs.
- IE0: Interrupt 0 edge detect: Set by hardware when an edge/level is detected on  $\overline{INT0}$ . This bit is cleared by hardware when the service routine is vectored to only if the interrupt was edge triggered. Otherwise it follows the pin.
- IT0: Interrupt 0 type control: Set/cleared by software to specify falling edge/ low level triggered external inputs.

## Timer Mode Control

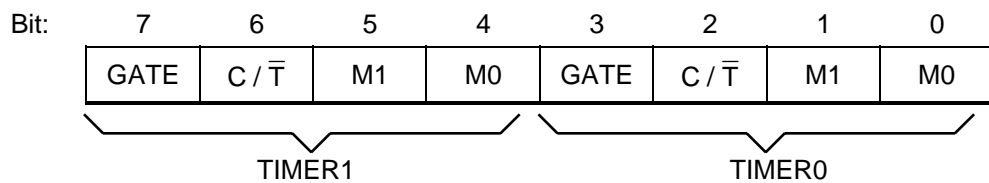

Mnemonic: TMOD

Address: 89h

- GATE: Gating control: When this bit is set, Timer/counter x is enabled only while  $\overline{INTx}$  pin is high and TRx control bit is set. When cleared, Timer x is enabled whenever TRx control bit is set.
- C /  $\overline{T}$ : Timer or Counter Select: When cleared, the timer is incremented by internal clocks. When set, the timer counts high-to-low edges of the Tx pin.



## M1, M0: Mode Select bits:

M1	M0	MODE
0	0	Mode 0: 8-bits with 5-bit prescale.
0	1	Mode 1: 18-bits, no prescale.
1	0	Mode 2: 8-bits with auto-reload from THx
1	1	Mode 3: (Timer 0) TL0 is an 8-bit timer/counter controlled by the standard Timer 0 control bits. TH0 is a 8-bit timer only controlled by Timer 1 control bits. (Timer 1) Timer/counter is stopped.

## Timer 0 LSB

Bit:	7	6	5	4	3	2	1	0
	TL0.7	TL0.6	TL0.5	TL0.4	TL0.3	TL0.2	TL0.1	TL0.0

Mnemonic: TL0

Address: 8Ah

TL0.7–0: Timer 0 LSB

## Timer 1 LSB

Bit:	7	6	5	4	3	2	1	0
	TL1.7	TL1.6	TL1.5	TL1.4	TL1.3	TL1.2	TL1.1	TL1.0

Mnemonic: TL1

Address: 8Bh

TL1.7–0: Timer 1 LSB

## Timer 0 MSB

Bit:	7	6	5	4	3	2	1	0
	TH0.7	TH0.6	TH0.5	TH0.4	TH0.3	TH0.2	TH0.1	TH0.0

Mnemonic: TH0

Address: 8Ch

TH0.7–0: Timer 0 MSB

## Timer 1 MSB

Bit:	7	6	5	4	3	2	1	0
	TH1.7	TH1.6	TH1.5	TH1.4	TH1.3	TH1.2	TH1.1	TH1.0

Mnemonic: TH1

Address: 8Dh

TH1.7–0: Timer 1 MSB



## Clock Control

Bit:	7	6	5	4	3	2	1	0
	WD1	WD0	T2M	T1M	T0M	MD2	MD1	MD0

Mnemonic: CKCON

Address: 8Eh

WD1–0: Watchdog timer mode select bits: These bits determine the time-out period for the watchdog timer. In all four time-out options the reset time-out is 512 clocks more than the interrupt time-out period.

WD1	WD0	Interrupt time-out	Reset time-out
0	0	$2^{17}$	$2^{17} + 512$
0	1	$2^{20}$	$2^{20} + 512$
1	0	$2^{23}$	$2^{23} + 512$
1	1	$2^{26}$	$2^{26} + 512$

T2M: Timer 2 clock select: When T2M is set to 1, timer 2 uses a divide by 4 clock, and when set to 0 it uses a divide by 12 clock.

T1M: Timer 1 clock select: When T1M is set to 1, timer 1 uses a divide by 4 clock, and when set to 0 it uses a divide by 12 clock.

T0M: Timer 0 clock select: When T0M is set to 1, timer 0 uses a divide by 4 clock, and when set to 0 it uses a divide by 12 clock.

MD2–0: Stretch MOVX select bits: These three bits are used to select the stretch value for the MOVX instruction. Using a variable MOVX length enables the user to access slower external memory devices or peripherals without the need for external circuits. The  $\overline{RD}$  or  $\overline{WR}$  strobe will be stretched by the selected interval. When accessing the on-chip SRAM, the MOVX instruction is always in 2 machine cycles regardless of the stretch setting. By default, the stretch has value of 1. If the user needs faster accessing, then a stretch value of 0 should be selected.

MD2	MD1	MD0	Stretch value	MOVX duration
0	0	0	0	2 machine cycles
0	0	1	1	3 machine cycles ( <i>Default</i> )
0	1	0	2	4 machine cycles
0	1	1	3	5 machine cycles
1	0	0	4	6 machine cycles
1	0	1	5	7 machine cycles
1	1	0	6	8 machine cycles
1	1	1	7	9 machine cycles



## Port 1

Bit:	7	6	5	4	3	2	1	0
	P1.7	P1.6	P1.5	P1.4	P1.3	P1.2	P1.1	P1.0

Mnemonic: P1

Address: 90h

P1.7–0: General purpose I/O port. Most instructions will read the port pins in case of a port read access, however in case of read-modify-write instructions, the port latch is read. Some pins also have alternate input or output functions. This alternate functions are described below:

P1.0 : T2 External I/O for Timer/Counter 2

P1.1 : T2EX Timer/Counter 2 Capture/Reload Trigger

## Port 4 Control Register A

Bit:	7	6	5	4	3	2	1	0
	P41M1	P41M0	P41C1	P41C0	P40M1	P40M0	P40C1	P40C0

Mnemonic: P4CONA

Address: 92h

## Port 4 Control Register B

Bit:	7	6	5	4	3	2	1	0
	P43M1	P43M0	P43C1	P43C0	P42M1	P42M0	P42C1	P42C0

Mnemonic: P4CONB

Address: 93h

BIT NAME	FUNCTION
P4xM1, P4xM0	<p>Port 4 alternate modes.</p> <p>=00: Mode 0. P4.x is a general purpose I/O port which is the same as Port 1.</p> <p>=01: Mode 1. P4.x is a Read Strobe signal for chip select purpose. The address range depends on the SFR P4xAH, P4xAL and bits P4xC1, P4xC0.</p> <p>=10: Mode 2. P4.x is a Write Strobe signal for chip select purpose. The address range depends on the SFR P4xAH, P4xAL and bits P4xC1, P4xC0.</p> <p>=11: Mode 3. P4.x is a Read/Write Strobe signal for chip select purpose. The address range depends on the SFR P4xAH, P4xAL and bits P4xC1, P4xC0</p>
P4xC1, P4xC0	<p>Port 4 Chip-select Mode address comparison:</p> <p>=00: Compare the full address (16 bits length) with the base address registers P4xAH and P4xAL.</p> <p>=01: Compare the 15 high bits (A15-A1) of address bus with the base address registers P4xAH and P4xAL.</p> <p>=10: Compare the 14 high bits (A15-A2) of address bus with the base address registers P4xAH and P4xAL.</p> <p>=11: Compare the 8 high bits (A15-A8) of address bus with the base address registers P4xAH and P4xAL.</p>



## P4.0 Base Address Low Byte Register

Bit:	7	6	5	4	3	2	1	0
	A7	A6	A5	A4	A3	A2	A1	A0

Mnemonic: P40AL

Address: 94h

## P4.0 Base Address High Byte Register

Bit:	7	6	5	4	3	2	1	0
	A15	A14	A13	A12	A11	A10	A9	A8

Mnemonic: P40AH

Address: 95h

## P4.1 Base Address Low Byte Register

Bit:	7	6	5	4	3	2	1	0
	A7	A6	A5	A4	A3	A2	A1	A0

Mnemonic: P41AL

Address: 96h

## P4.1 Base Address High Byte Register

Bit:	7	6	5	4	3	2	1	0
	A15	A14	A13	A12	A11	A10	A9	A8

Mnemonic: P41AH

Address: 97h

## Serial Port Control

Bit:	7	6	5	4	3	2	1	0
	SM0/FE	SM1	SM2	REN	TB8	RB8	TI	RI

Mnemonic: SCON

Address: 98h

**SM0/FE:** Serial port 0, Mode 0 bit or Framing Error Flag: The SMOD0 bit in PCON SFR determines whether this bit acts as SM0 or as FE. The operation of SM0 is described below. When used

as FE, this bit will be set to indicate an invalid stop bit. This bit must be manually cleared in software to clear the FE condition.

**SM1:** Serial port Mode bit 1:

SM0	SM1	Mode	Description	Length	Baud rate
0	0	0	Synchronous	8	4/12 Tclk
0	1	1	Asynchronous	10	Variable
1	0	2	Asynchronous	11	64/32 Tclk
1	1	3	Asynchronous	11	Variable

**SM2:** Multiple processors communication. Setting this bit to 1 enables the multiprocessor communication feature in mode 2 and 3. In mode 2 or 3, if SM2 is set to 1, then RI will not be activated if the received 9th data bit (RB8) is 0. In mode 1, if SM2 = 1, then RI will not be activated if a valid stop bit was not received. In mode 0, the SM2 bit controls the serial port clock. If set to 0, then the serial port runs at a divide by 12 clock of the oscillator. This gives

# Preliminary W79E648



compatibility with the standard 8052. When set to 1, the serial clock become divide by 4 of the oscillator clock. This results in faster synchronous serial communication.

- REN: Receive enable: When set to 1 serial reception is enabled, otherwise reception is disabled.
- TB8: This is the 9th bit to be transmitted in modes 2 and 3. This bit is set and cleared by software as desired.
- RB8: In modes 2 and 3 this is the received 9th data bit. In mode 1, if SM2 = 0, RB8 is the stop bit that was received. In mode 0 it has no function.
- TI: Transmit interrupt flag: This flag is set by hardware at the end of the 8th bit time in mode 0, or at the beginning of the stop bit in all other modes during serial transmission. This bit must be cleared by software.
- RI: Receive interrupt flag: This flag is set by hardware at the end of the 8th bit time in mode 0, or halfway through the stop bits time in the other modes during serial reception. However the restrictions of SM2 apply to this bit. This bit can be cleared only by software.

## Serial Data Buffer

Bit:	7	6	5	4	3	2	1	0
	SBUF.7	SBUF.6	SBUF.5	SBUF.4	SBUF.3	SBUF.2	SBUF.1	SBUF.0

Mnemonic: SBUF

Address: 99h

SBUF.7-0: Serial data on the serial port 0 is read from or written to this location. It actually consists of two separate internal 8-bit registers. One is the receive register, and the other is the transmit buffer. Any read access gets data from the receive data buffer, while write access is to the transmit data buffer.

## P4.2 Base Address Low Byte Register

Bit:	7	6	5	4	3	2	1	0
	A7	A6	A5	A4	A3	A2	A1	A0

Mnemonic: P42AL

Address: 9Ah

## P4.2 Base Address High Byte Register

Bit:	7	6	5	4	3	2	1	0
	A15	A14	A13	A12	A11	A10	A9	A8

Mnemonic: P42AH

Address: 9Bh

## P4.3 Base Address Low Byte Register

Bit:	7	6	5	4	3	2	1	0
	A7	A6	A5	A4	A3	A2	A1	A0

Mnemonic: P43AL

Address: 9Ch



## P4.3 Base Address High Byte Register

Bit:	7	6	5	4	3	2	1	0
	A15	A14	A13	A12	A11	A10	A9	A8

Mnemonic: P43AH

Address: 9Dh

## ISP Control Register

Bit:	7	6	5	4	3	2	1	0
	SWRST/HWB	-	LDAP	-	-	-	LDSEL	ENP

Mnemonic: CHPCON

Address: 9Fh

**SWRST/HWB:** Set this bit to launch a whole device reset that is same as asserting high to RST pin, micro controller will be back to initial state and clear this bit automatically. To read this bit, its alternate function to indicate the ISP hardware reboot mode is invoking when read it in high.

**LDAP:** This bit is Read Only. High: device is executing the program in LDFlash. Low: device is executing the program in APFlashes.

**LDSEL:** Loader program residence selection. Set to high to route the device fetching code from LDFlash.

**ENP:** In System Programming Mode Enable. Set this be to launch the ISP mode. Device will operate ISP procedures, such as Erase, Program and Read operations, according to correlative SFRs settings. During ISP mode, device achieves ISP operations by the way of IDLE state. In the other words, device is not indeed in IDLE mode is set bit PCON.1 while ISP is enabled. Clear this bit to disable ISP mode, device get back to normal operation including IDLE state.



## Software Reset

Set CHPCON = 0X83, timer and enter IDLE mode. CPU will reset and restart from APFlash after time out.

## Port 2

Bit:	7	6	5	4	3	2	1	0
	P2.7	P2.6	P2.5	P2.4	P2.3	P2.2	P2.1	P2.0

Mnemonic: P2

Address: A0h

P2.7-0: Port 2 is a bi-directional I/O port with internal pull-ups. This port also provides the upper address bits for accesses to external memory.

## Port 4 Chip-select Polarity

Bit:	7	6	5	4	3	2	1	0
	P43INV	P42INV	P42INV	P40INV	-	-	-	PUP0

6.1.1 Mnemonic: P4CSIN

Address: A2h

P4xINV: The active polarity of P4.x when set it as chip-select signal. High = Active High. Low = Active Low.

PUP0: Enable Port 0 weak pull up.

## Port 4

Bit:	7	6	5	4	3	2	1	0
	-	-	-	-	P4.3	P4.2	P4.1	P4.0

Mnemonic: P4

Address: A5h

P4.3-0: Port 4 is a bi-directional I/O port with internal pull-ups. Port 4 can not use bit-addressable instruction (SETB or CLR).

## Interrupt Enable

Bit:	7	6	5	4	3	2	1	0
	EA	ES1	ET2	ES	ET1	EX1	ET0	EX0

Mnemonic: IE

Address: A8h

EA: Global enable. Enable/disable all interrupts.

ET2: Enable Timer 2 interrupt.

ES: Enable Serial Port 0 interrupt.

ET1: Enable Timer 1 interrupt

EX1: Enable external interrupt 1

ET0: Enable Timer 0 interrupt

EX0: Enable external interrupt 0

# Preliminary W79E648



## Slave Address

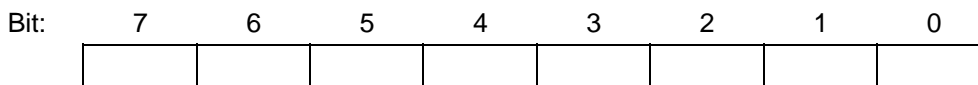

Mnemonic: SADDR

Address: A9h

SADDR: The SADDR should be programmed to the given or broadcast address for serial port 0 to which the slave processor is designated.

## ROM Banking Control

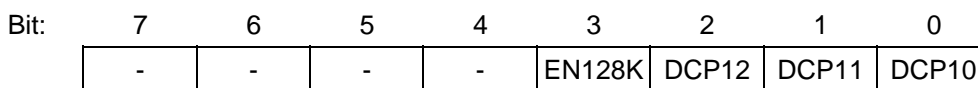

Mnemonic: ROMCON

Address: ABh

EN128K: On-chip ROM banking enable. Set this bit to enable APFlash0 and APFlash1 by banking mechanism. The P1.x is selected to be the auxiliary highest address line A16.

DCP1x: A16 selection. By default, P1.7 is defined as A16.

A16	P1.0	P1.1	P1.2	P1.3	P1.4	P1.5	P1.6	P1.7
DCP12	0	0	0	0	1	1	1	1
DCP11	0	0	1	1	0	0	1	1
DCP10	0	1	0	1	0	1	0	1

## ISP Address Low Byte

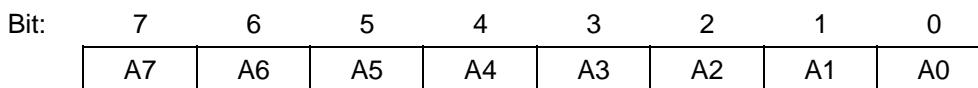

Mnemonic: SFRAL

Address: ACh

Low byte destination address for In System Programming operations. SFRAH and SFRAL address a specific ROM bytes for erasure, programming or read.

## ISP Address High Byte

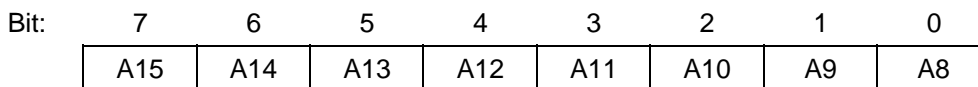

Mnemonic: SFRAH

Address: ADh

High byte destination address for In System Programming operations. SFRAH and SFRAL address a specific ROM bytes for erasure, programming or read.

## ISP Data Buffer

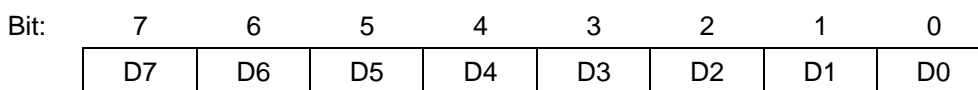

Mnemonic: SFRFD

Address: AEh

In ISP mode, read/write a specific byte ROM content must go through SFRFD register.

# Preliminary W79E648



## ISP Operation Modes

Bit:	7	6	5	4	3	2	1	0
	BANK	WFWIN	NOE	NCE	CTRL3	CTRL2	CTRL1	CTRL0

Mnemonic: SFRCN

Address: AFh

**BANK:** Select APFlash banks for ISP. Set it 1 access to APFlash1, clear it to APFlash0.

**WFWIN:** Destination ROM bank for programming, erasure and read. 0 = APFlashx, 1 = LDFlash.

**NOE:** Flash EPROM output enable.

**NCE:** Flash EPROM chip enable.

**CTRL[3:0]:** Mode Selection.

ISP Mode	BANK	WFWIN	NOE	NCE	CTRL<3:0>	SFRAH, SFRAL	SFRFD
Erase 4KB LDFlash	0	1	1	0	0010	X	X
Erase 64K APFlash0	0	0	1	0	0010	X	X
Erase 64K APFlash1	1	0	1	0	0010	X	X
Program 4KB LDFlash	0	1	1	0	0001	Address in	Data in
Program 64KB APFlash0	0	0	1	0	0001	Address in	Data in
Program 64KB APFlash1	1	0	1	0	0001	Address in	Data in
Read 4KB LDFlash	0	1	0	0	0000	Address in	Data out
Read 64KB APFlash0	0	0	0	0	0000	Address in	Data out
Read 64KB APFlash1	1	0	0	0	0000	Address in	Data out

## Port 3

Bit:	7	6	5	4	3	2	1	0
	P3.7	P3.6	P3.5	P3.4	P3.3	P3.2	P3.1	P3.0

Mnemonic: P3

Address: B0h

P3.7-0: General purpose I/O port. Each pin also has an alternate input or output function. The alternate functions are described below.

P3.7	$\overline{RD}$	Strobe for read from external RAM
P3.6	$\overline{WR}$	Strobe for write to external RAM
P3.5	T1	Timer/counter 1 external count input
P3.4	T0	Timer/counter 0 external count input
P3.3	$\overline{INT1}$	External interrupt 1
P3.2	$\overline{INT0}$	External interrupt 0
P3.1	TxD	Serial port 0 output
P3.0	RxD	Serial port 0 input

# Preliminary W79E648



## Port 5

Bit:	7	6	5	4	3	2	1	0
	P5.7	P5.6	P5.5	P5.4	P5.3	P5.2	P5.1	P5.0

Mnemonic: P5

Address: B1h

P5.7-0: General purpose I/O port. Port 5 can not use bit-addressable instruction (SETB or CLR).

Demo code:

ORL P5,#00000010B ; Set P5.1=H

ANL P5,#11111101B ; Clear P5.1=L

## Port 6

Bit:	7	6	5	4	3	2	1	0
	P6.7	P6.6	P6.5	P6.4	P6.3	P6.2	P6.1	P6.0

Mnemonic: P6

Address: B2h

P6.7-0: General purpose I/O port. Port 6 can not use bit-addressable instruction (SETB or CLR).

## Port 7

Bit:	7	6	5	4	3	2	1	0
	P7.7	P7.6	P7.5	P7.4	P7.3	P7.2	P7.1	P7.0

Mnemonic: P7

Address: B3h

P7.7-0: General purpose I/O port. Port 7 can not use bit-addressable instruction (SETB or CLR).



## Interrupt Priority

Bit:	7	6	5	4	3	2	1	0
	-	-	PT2	PS	PT1	PX1	PT0	PX0

Mnemonic: IP

Address: B8h

- IP.7: This bit is un-implemented and will read high.
- PT2: This bit defines the Timer 2 interrupt priority. PT2 = 1 sets it to higher priority level.
- PS: This bit defines the Serial port 0 interrupt priority. PS = 1 sets it to higher priority level.
- PT1: This bit defines the Timer 1 interrupt priority. PT1 = 1 sets it to higher priority level.
- PX1: This bit defines the External interrupt 1 priority. PX1 = 1 sets it to higher priority level.
- PT0: This bit defines the Timer 0 interrupt priority. PT0 = 1 sets it to higher priority level.
- PX0: This bit defines the External interrupt 0 priority. PX0 = 1 sets it to higher priority level.

## Slave Address Mask Enable

Bit:	7	6	5	4	3	2	1	0

Mnemonic: SADEN

Address: B9h

SADEN: This register enables the Automatic Address Recognition feature of the Serial port 0. When a bit in the SADEN is set to 1, the same bit location in SADDR will be compared with the incoming serial data. When SADEN.n is 0, then the bit becomes a "don't care" in the comparison. This register enables the Automatic Address Recognition feature of the Serial port 0. When all the bits of SADEN are 0, interrupt will occur for any incoming address.

## Power Management Register

Bit:	7	6	5	4	3	2	1	0
	-	-	-	-	-	ALE-OFF	-	DME0

Mnemonic: PMR

Address: C4h

ALEOFF: This bit disables the expression of the ALE signal on the device pin during all on-board program and data memory accesses. External memory accesses will automatically enable ALE independent of ALEOFF.

0 = ALE expression is enable; 1 = ALE expression is disable

DME0: This bit determines the on-chip MOVX SRAM to be enabled or disabled. Set this bit to 1 will enable the on-chip 1KB MOVX SRAM.

## Status Register

Bit:	7	6	5	4	3	2	1	0
	-	HIP	LIP	-	-	-	-	-

Mnemonic: STATUS

Address: C5h



**HIP:** High Priority Interrupt Status. When set, it indicates that software is servicing a high priority interrupt. This bit will be cleared when the program executes the corresponding RETI instruction.

**LIP:** Low Priority Interrupt Status. When set, it indicates that software is servicing a low priority interrupt. This bit will be cleared when the program executes the corresponding RETI instruction.

## Timed Access

Bit:	7	6	5	4	3	2	1	0
	TA.7	TA.6	TA.5	TA.4	TA.3	TA.2	TA.1	TfA.0

Mnemonic: TA

Address: C7h

**TA:** The Timed Access register controls the access to protected bits. To access protected bits, the user must first write AAH to the TA. This must be immediately followed by a write of 55H to TA. Now a window is opened in the protected bits for three machine cycles, during which the user can write to these bits.

## Timer 2 Control

Bit:	7	6	5	4	3	2	1	0
	TF2	EXF2	RCLK	TCLK	EXEN2	TR2	C / $\overline{T2}$	CP / $\overline{RL2}$

Mnemonic: T2CON

Address: C8h

**TF2:** Timer 2 overflow flag: This bit is set when Timer 2 overflows. It is also set when the count is equal to the capture register in down count mode. It can be set only if RCLK and TCLK are both 0. It is cleared only by software. Software can also set or clear this bit.

**EXF2:** Timer 2 External Flag: A negative transition on the T2EX pin (P1.1) or timer 2 overflow will cause this flag to set based on the CP /  $\overline{RL2}$ , EXEN2 and DCEN bits. If set by a negative transition, this flag must be cleared by software. Setting this bit in software or detection of a negative transition on T2EX pin will force a timer interrupt if enabled.

**RCLK:** Receive Clock Flag: This bit determines the serial port 0 time-base when receiving data in serial modes 1 or 3. If it is 0, then timer 1 overflow is used for baud rate generation, otherwise timer 2 overflow is used. Setting this bit forces timer 2 in baud rate generator mode.

**TCLK:** Transmit Clock Flag: This bit determines the serial port 0 time-base when transmitting data in modes 1 and 3. If it is set to 0, the timer 1 overflow is used to generate the baud rate clock otherwise timer 2 overflow is used. Setting this bit forces timer 2 in baud rate generator mode.

**EXEN2:** Timer 2 External Enable. This bit enables the capture/reload function on the T2EX pin if Timer 2 is not generating baud clocks for the serial port. If this bit is 0, then the T2EX pin will be ignored, otherwise a negative transition detected on the T2EX pin will result in capture or reload.

**TR2:** Timer 2 Run Control. This bit enables/disables the operation of timer 2. Clearing this bit will halt the timer 2 and preserve the current count in TH2, TL2.

**C /  $\overline{T2}$ :** Counter/Timer Select. This bit determines whether timer 2 will function as a timer or a counter. Independent of this bit, the timer will run at 2 clocks per tick when used in baud rate generator mode. If it is set to 0, then timer 2 operates as a timer at a speed depending on T2M bit (CKCON.5), otherwise it will count negative edges on T2 pin.



**CP/RL2**: Capture/Reload Select. This bit determines whether the capture or reload function will be used for timer 2. If either RCLK or TCLK is set, this bit will be ignored and the timer will function in an auto-reload mode following each overflow. If the bit is 0 then auto-reload will occur when timer 2 overflows or a falling edge is detected on T2EX pin if EXEN2 = 1. If this bit is 1, then timer 2 captures will occur when a falling edge is detected on T2EX pin if EXEN2 = 1.

### Timed 2 Mode Control

Bit:	7	6	5	4	3	2	1	0
	-	-	-	-	T2CR	-	-	DCEN

Mnemonic: T2MOD

Address: C9h

**T2CR**: Timer 2 Capture Reset. In the Timer 2 Capture Mode this bit enables/disables hardware automatically reset Timer 2 while the value in TL2 and TH2 have been transferred into the capture register.

**DCEN**: Down Count Enable: This bit, in conjunction with the T2EX pin, controls the direction that timer 2 counts in 16-bit auto-reload mode.

### Timer 2 Capture LSB

Bit:	7	6	5	4	3	2	1	0
	RCAP2L.7	RCAP2L.6	RCAP2L.5	RCAP2L.4	RCAP2L.3	RCAP2L.2	RCAP2L.1	RCAP2L.0

Mnemonic: RCAP2L

Address: CAh

**RCAP2L**: This register is used to capture the TL2 value when a timer 2 is configured in capture mode. RCAP2L is also used as the LSB of a 16-bit reload value when timer 2 is configured in auto-reload mode.

### Timer 2 Capture MSB

Bit:	7	6	5	4	3	2	1	0
	RCAP2H.7	RCAP2H.6	RCAP2H.5	RCAP2H.4	RCAP2H.3	RCAP2H.2	RCAP2H.1	RCAP2H.0

Mnemonic: RCAP2H

Address: CBh

**RCAP2H**: This register is used to capture the TH2 value when a timer 2 is configured in capture mode.

RCAP2H is also used as the MSB of a 16-bit reload value when timer 2 is configured in auto-reload mode.

### Timer 2 LSB

Bit:	7	6	5	4	3	2	1	0
	TL2.7	TL2.6	TL2.5	TL2.4	TL2.3	TL2.2	TL2.1	TL2.0

Mnemonic: TL2

Address: CCh

**TL2**: Timer 2 LSB



## Timer 2 MSB

Bit:	7	6	5	4	3	2	1	0
	TH2.7	TH2.6	TH2.5	TH2.4	TH2.3	TH2.2	TH2.1	TH2.0

Mnemonic: TH2

Address: CDh

TH2: Timer 2 MSB

## Program Status Word

Bit:	7	6	5	4	3	2	1	0
	CY	AC	F0	RS1	RS0	OV	F1	P

Mnemonic: PSW

Address: D0h

CY: Carry flag: Set for an arithmetic operation which results in a carry being generated from the ALU. It is also used as the accumulator for the bit operations.

AC: Auxiliary carry: Set when the previous operation resulted in a carry from the high order nibble.

F0: User flag 0: General purpose flag that can be set or cleared by the user.

RS.1-0: Register bank select bits:

RS1	RS0	Register bank	Address
0	0	0	00-07h
0	1	1	08-0Fh
1	0	2	10-17h
1	1	3	18-1Fh

OV: Overflow flag: Set when a carry was generated from the seventh bit but not from the 8th bit as a result of the previous operation, or vice-versa.

F1: User Flag 1: General purpose flag that can be set or cleared by the user by software.

P: Parity flag: Set/cleared by hardware to indicate odd/even number of 1's in the accumulator.

## Watchdog Control

Bit:	7	6	5	4	3	2	1	0
	-	POR	-	-	WDIF	WTRF	EWT	RWT

Mnemonic: WDCON

Address: D8h

POR: Power-on reset flag. Hardware will set this flag on a power up condition. This flag can be read or written by software. A write by software is the only way to clear this bit once it is set.

WDIF: Watchdog Timer Interrupt Flag. If the watchdog interrupt is enabled, hardware will set this bit to indicate that the watchdog interrupt has occurred. If the interrupt is not enabled, then this bit indicates that the time-out period has elapsed. This bit must be cleared by software.

WTRF: Watchdog Timer Reset Flag. Hardware will set this bit when the watchdog timer causes a reset. Software can read it but must clear it manually. A power-fail reset will also clear the bit. This bit helps software in determining the cause of a reset. If EWT = 0, the watchdog timer will have no affect on this bit.

EWT: Enable Watchdog timer Reset. Setting this bit will enable the Watchdog timer Reset function.





B.7-0: The B register is the standard 8052 register that serves as a second accumulator.

### Extended Interrupt Priority

Bit:	7	6	5	4	3	2	1	0
	-	-	-	PWDI	-	-	-	-

Mnemonic: EIP Address: F8h

EIP.7-5: Reserved bits.

PWDI: Watchdog timer interrupt priority.

## 7. INSTRUCTION

The W79E648 executes all the instructions of the standard 8032 family. The operation of these instructions, their effect on the flag bits and the status bits is exactly the same. However, timing of these instructions is different. The reason for this is two fold. Firstly, in the W79E648, each machine cycle consists of 4 clock periods, while in the standard 8032 it consists of 12 clock periods. Also, in the W79E648 there is only one fetch per machine cycle i.e. 4 clocks per fetch, while in the standard 8032 there can be two fetches per machine cycle, which works out to 6 clocks per fetch.

The advantage the W79E648 has is that since there is only one fetch per machine cycle, the number of machine cycles in most cases is equal to the number of operands that the instruction has. In case of jumps and calls there will be an additional cycle that will be needed to calculate the new address. But overall the W79E648 reduces the number of dummy fetches and wasted cycles, thereby improving efficiency as compared to the standard 8032.

### 7.1 Instruction Timing

The instruction timing for the W79E648 is an important aspect, especially for those users who wish to use software instructions to generate timing delays. Also, it provides the user with an insight into the timing differences between the W79E648 and the standard 8032. In the W79E648 each machine cycle is four clock periods long. Each clock period is designated a state. Thus each machine cycle is made up of four states, C1, C2 C3 and C4, in that order. Due to the reduced time for each instruction execution, both the clock edges are used for internal timing. Hence it is important that the duty cycle of the clock be as close to 50% as possible to avoid timing conflicts. As mentioned earlier, the W79E648 does one op-code fetch per machine cycle. Therefore, in most of the instructions, the number of machine cycles needed to execute the instruction is equal to the number of bytes in the instruction. Of the 256 available op-codes, 128 of them are single cycle instructions. Thus more than half of all op-codes in the W79E648 are executed in just four clock periods. Most of the two-cycle instructions are those that have two byte instruction codes. However there are some instructions that have only one byte instructions, yet they are two cycle instructions. One instruction which is of importance is the MOVX instruction. In the standard 8032, the MOVX instruction is always two machine cycles long. However in the W79E648, the user has a facility to stretch the duration of this instruction from 2 machine cycles to 9 machine cycles. The  $\overline{RD}$  and  $\overline{WR}$  strobe lines are also proportionately elongated. This gives the user flexibility in accessing both fast and slow peripherals without the use of external circuitry and with minimum software overhead. The rest of the instructions are either three, four or five machine cycle instructions. Note that in the W79E648, based on the number of machine cycles, there are five different types, while in the standard 8032 there are only three. However, in the W79E648 each machine cycle is made of only 4 clock periods compared to the 12 clock periods for

# Preliminary W79E648



the standard 8032. Therefore, even though the number of categories has increased, each instruction is at least 1.5 to 3 times faster than the standard 8032 in terms of clock periods.

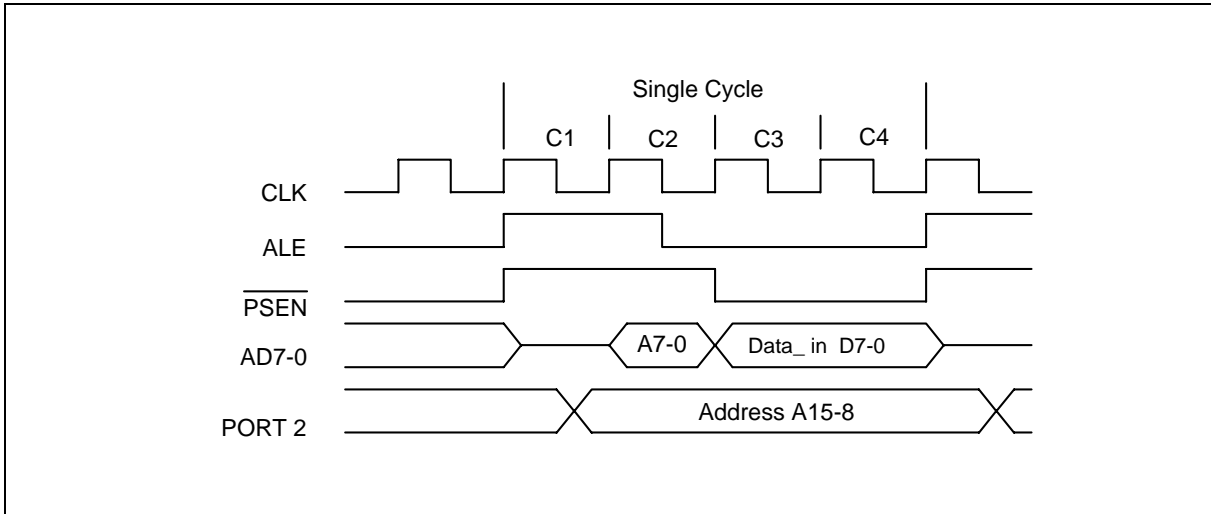

Figure 3. Single Cycle Instruction Timing

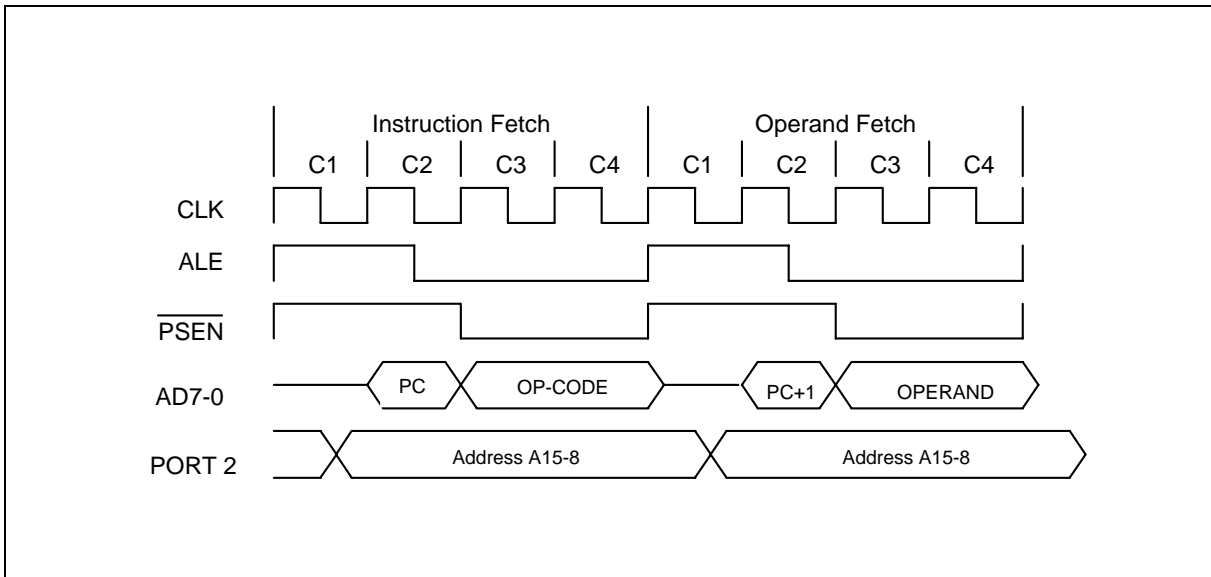

Figure 4. Two Cycle Instruction Timing

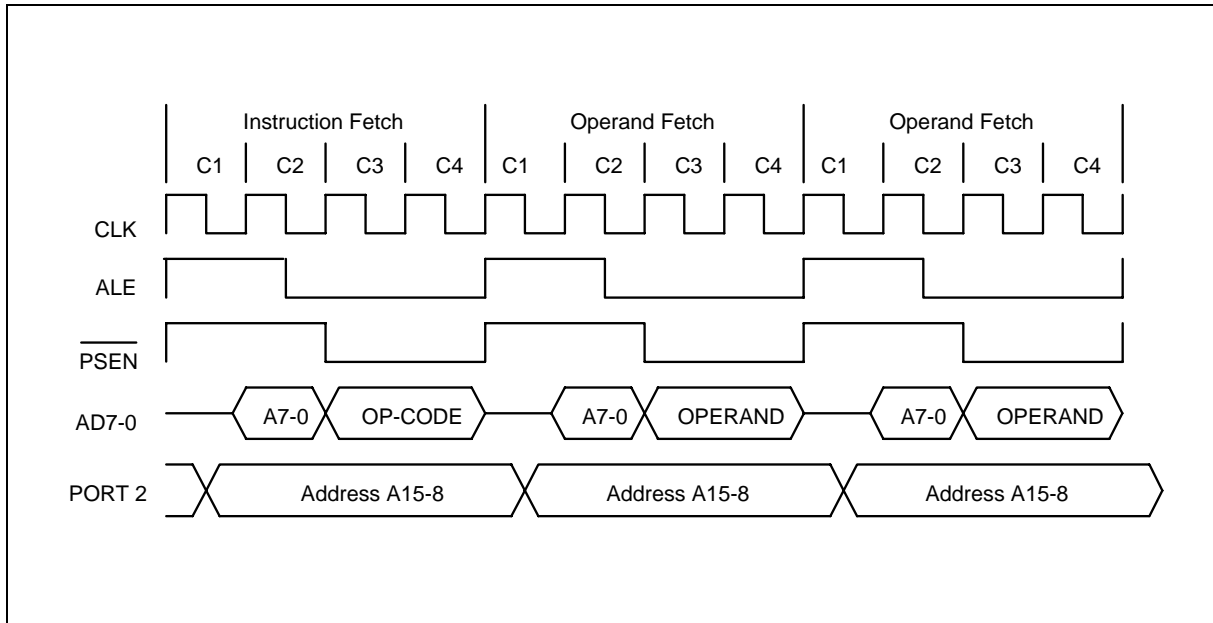

Figure 5. Three Cycle Instruction Timing

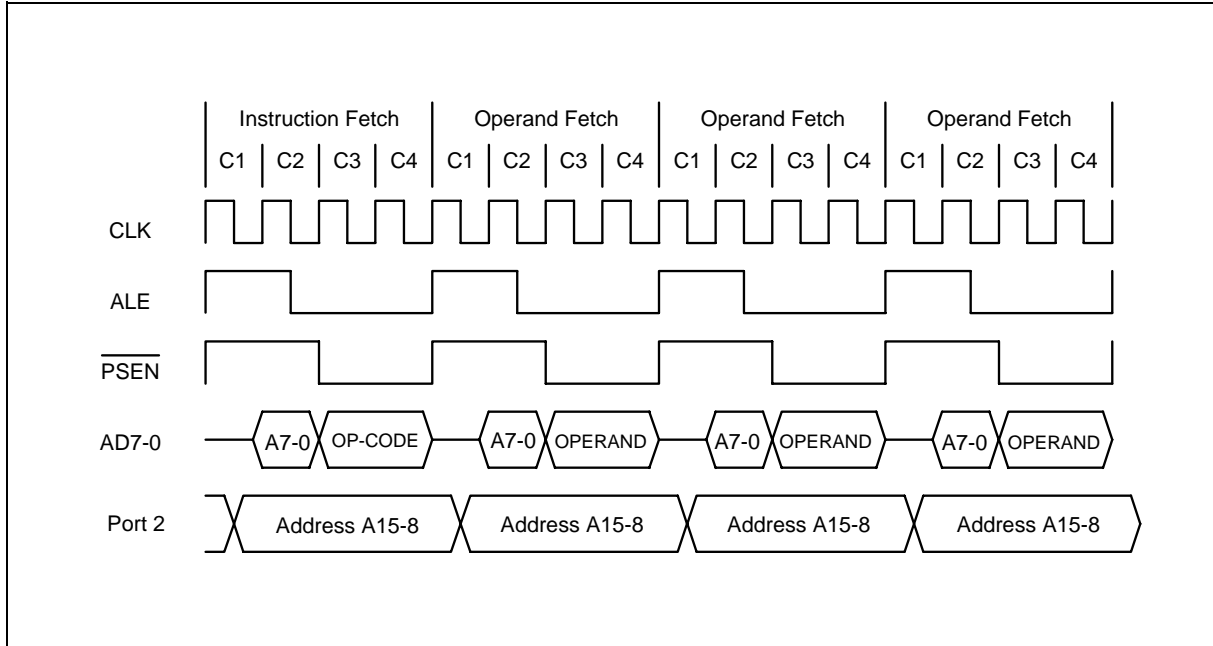

Figure 6. Four Cycle Instruction Timing

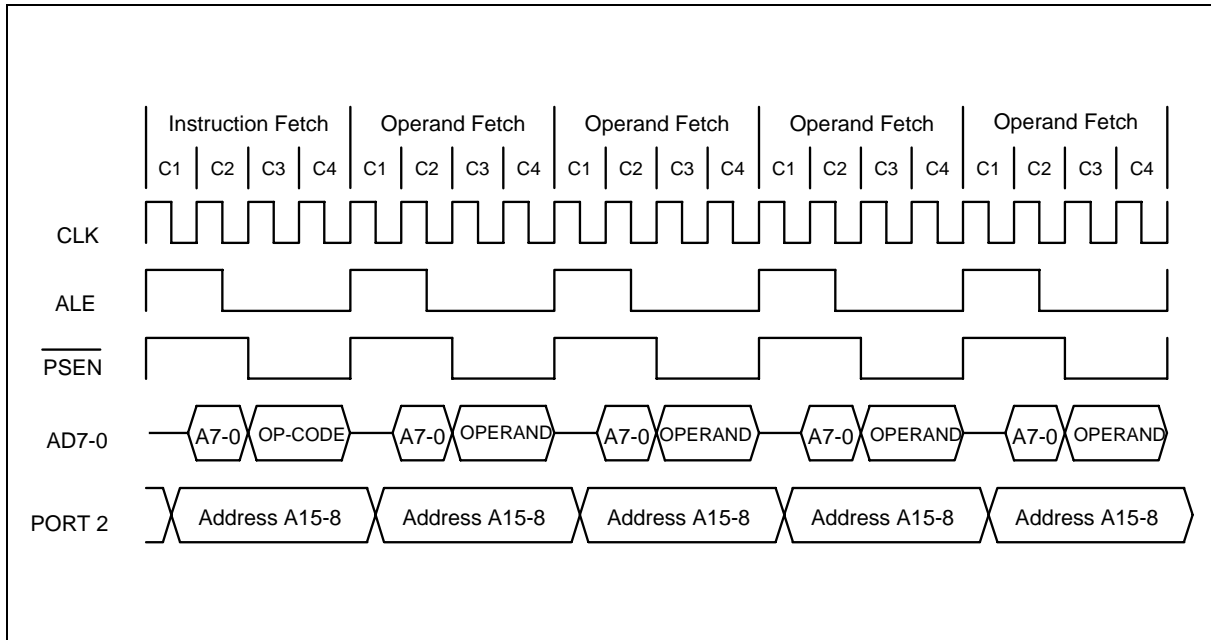

Figure 7. Five Cycle Instruction Timing

## 7.1.1 External Data Memory Access Timing

The timing for the MOVX instruction is another feature of the W79E648. In the standard 8032, the MOVX instruction has a fixed execution time of 2 machine cycles. However in the W79E648, the duration of the access can be varied by the user.

The instruction starts off as a normal op-code fetch of 4 clocks. In the next machine cycle, the W79E648 puts out the address of the external Data Memory and the actual access occurs here. The user can change the duration of this access time by setting the STRETCH value. The Clock Control SFR (CKCON) has three bits that control the stretch value. These three bits are M2-0 (bits 2-0 of CKCON). These three bits give the user 8 different access time options. The stretch can be varied from 0 to 7, resulting in MOVX instructions that last from 2 to 9 machine cycles in length. Note that the stretching of the instruction only results in the elongation of the MOVX instruction, as if the state of the CPU was held for the desired period. There is no effect on any other instruction or its timing. By default, the Stretch value is set at 1, giving a MOVX instruction of 3 machine cycles. If desired by the user the stretch value can be set to 0 to give the fastest MOVX instruction of only 2 machine cycles.

Table 4. Data Memory Cycle Stretch Values

M2	M1	M0	Machine Cycles	$\overline{RD}$ or $\overline{WR}$ strobe width in Clocks	$\overline{RD}$ or $\overline{WR}$ strobe width @ 25 MHz	$\overline{RD}$ or $\overline{WR}$ strobe width @ 40 MHz
0	0	0	2	2	80 nS	50 nS
0	0	1	3 (default)	4	160 nS	100 nS
0	1	0	4	8	320 nS	200 nS

# Preliminary W79E648



Continued

M2	M1	M0	Machine Cycles	$\overline{RD}$ or $\overline{WR}$ strobe width in Clocks	$\overline{RD}$ or $\overline{WR}$ strobe width @ 25 MHz	$\overline{RD}$ or $\overline{WR}$ strobe width @ 40 MHz
0	1	1	5	12	480 nS	300 nS
1	0	0	6	16	640 nS	400 nS
1	0	1	7	20	800 nS	500 nS
1	1	0	8	24	960 nS	600 nS
1	1	1	9	28	1120 nS	700 nS

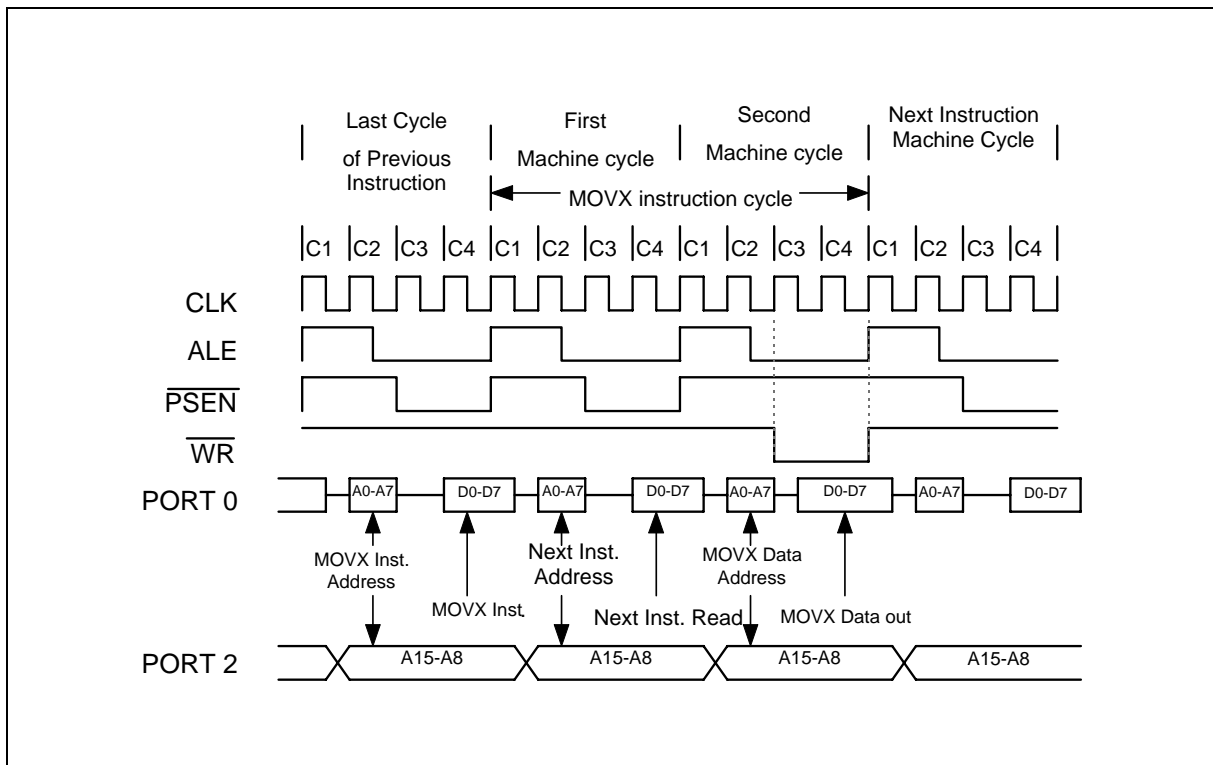

Figure 8. Data Memory Write with Stretch Value = 0

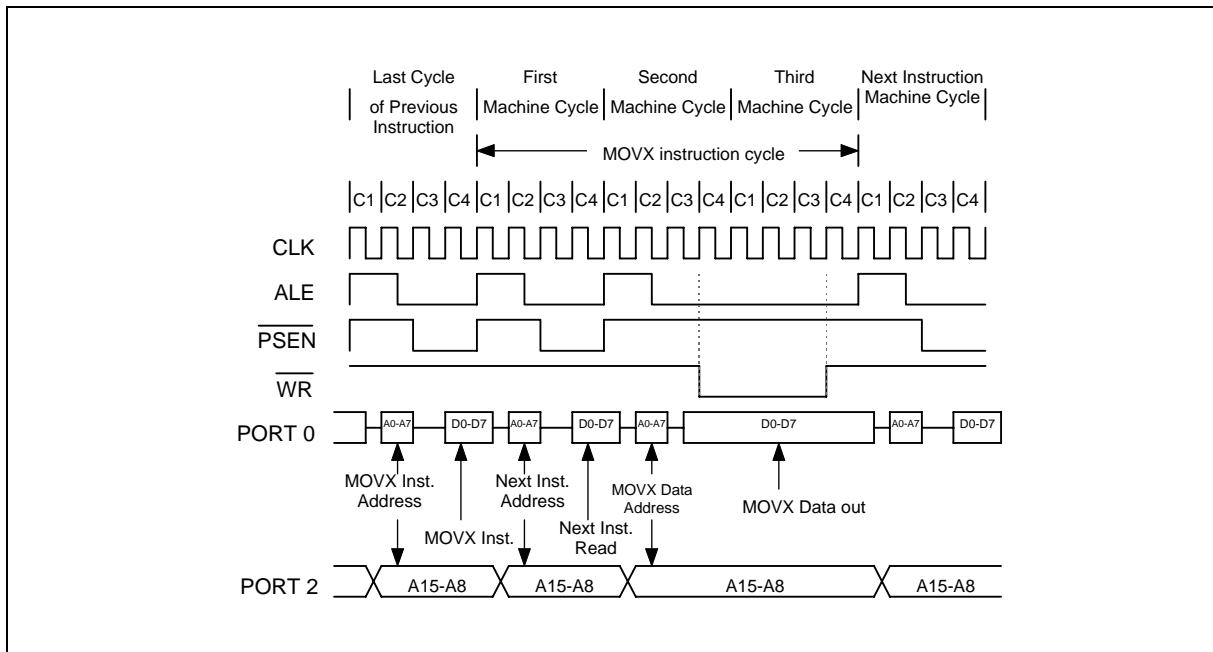

Figure 9. Data Memory Write with Stretch Value = 1

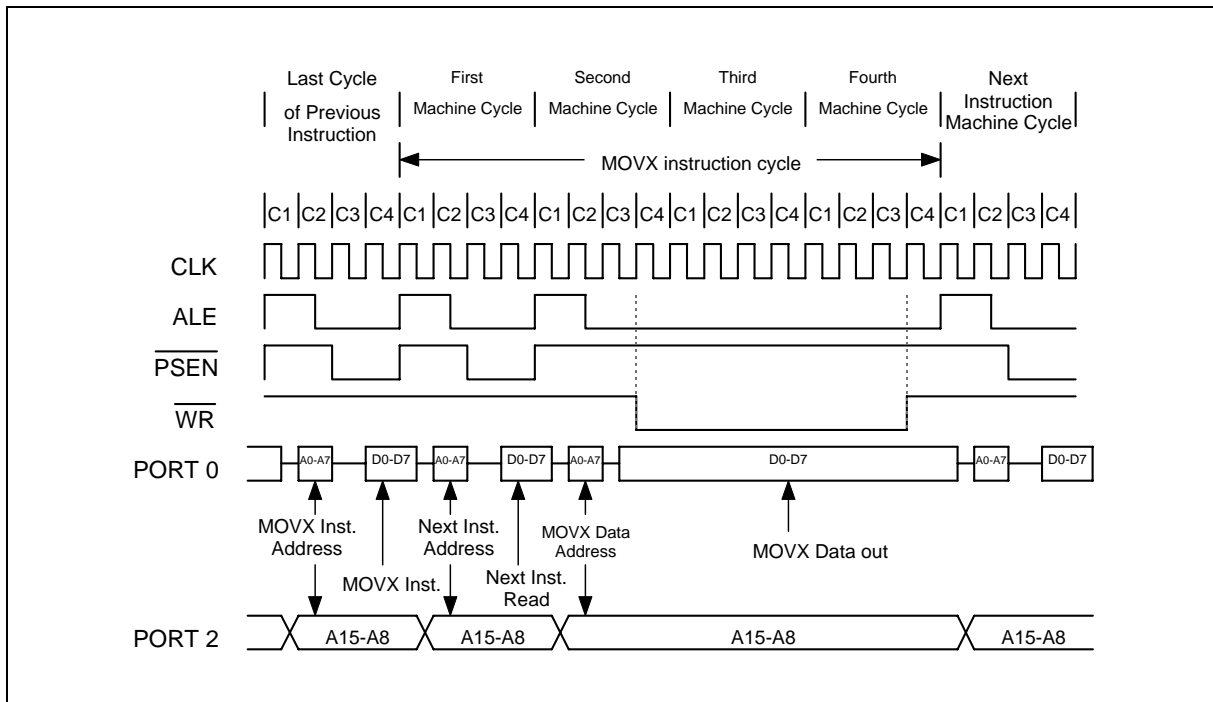

Figure 10. Data Memory Write with Stretch Value = 2



## 8. POWER MANAGEMENT

The W79E648 has several features that help the user to control the power consumption of the device. The power saving features are basically the POWER DOWN mode, ECONOMY mode and the IDLE mode of operation.

### Idle Mode

The user can put the device into idle mode by writing 1 to the bit PCON.0. The instruction that sets the idle bit is the last instruction that will be executed before the device goes into Idle Mode. In the Idle mode, the clock to the CPU is halted, but not to the Interrupt, Timer, Watchdog timer and Serial port blocks. This forces the CPU state to be frozen; the Program counter, the Stack Pointer, the Program Status Word, the Accumulator and the other registers hold their contents. The ALE and PSEN pins are held high during the Idle state. The port pins hold the logical states they had at the time Idle was activated. The Idle mode can be terminated in two ways. Since the interrupt controller is still active, the activation of any enabled interrupt can wake up the processor. This will automatically clear the Idle bit, terminate the Idle mode, and the Interrupt Service Routine (ISR) will be executed. After the ISR, execution of the program will continue from the instruction which put the device into Idle mode.

The Idle mode can also be exited by activating the reset. The device can be put into reset either by applying a high on the external RST pin, a Power on reset condition or a Watchdog timer reset. The external reset pin has to be held high for at least two machine cycles i.e. 8 clock periods to be recognized as a valid reset. In the reset condition the program counter is reset to 0000h and all the SFRs are set to the reset condition. Since the clock is already running there is no delay and execution starts immediately. In the Idle mode, the Watchdog timer continues to run, and if enabled, a time-out will cause a watchdog timer interrupt which will wake up the device. The software must reset the Watchdog timer in order to preempt the reset which will occur after 512 clock periods of the time-out. When the W79E648 is exiting from an Idle mode with a reset, the instruction following the one which put the device into Idle mode is not executed. So there is no danger of unexpected writes.

### Power Down Mode

The device can be put into Power Down mode by writing 1 to bit PCON.1. The instruction that does this will be the last instruction to be executed before the device goes into Power Down mode. In the Power Down mode, all the clocks are stopped and the device comes to a halt. All activity is completely stopped and the power consumption is reduced to the lowest possible value. In this state the ALE and PSEN pins are pulled low. The port pins output the values held by their respective SFRs.

The W79E648 will exit the Power Down mode with a reset or by an external interrupt pin enabled as level detect. An external reset can be used to exit the Power down state. The high on RST pin terminates the Power Down mode, and restarts the clock. The program execution will restart from 0000h. In the Power down mode, the clock is stopped, so the Watchdog timer cannot be used to provide the reset to exit Power down mode.

The W79E648 can be woken from the Power Down mode by forcing an external interrupt pin activated, provided the corresponding interrupt is enabled, while the global enable (EA) bit is set and the external input has been set to a level detect mode. If these conditions are met, then the low level on the external pin re-starts the oscillator. Then device executes the interrupt service routine for the corresponding external interrupt. After the interrupt service routine is completed, the program execution returns to the instruction after the one which put the device into Power Down mode and continues from there.



**Table 5. Status of external pins during Idle and Power Down**

Mode	Program Memory	ALE	$\overline{\text{PSEN}}$	PORT0	PORT1	PORT2	PORT3
Idle	Internal	1	1	Data	Data	Data	Data
Idle	External	1	1	Float	Data	Address	Data
Power Down	Internal	0	0	Data	Data	Data	Data
Power Down	External	0	0	Float	Data	Data	Data

## Reset Conditions

The user has several hardware related options for placing the W79E648 into reset condition. In general, most register bits go to their reset value irrespective of the reset condition, but there are a few flags whose state depends on the source of reset. The user can use these flags to determine the cause of reset using software. There are two ways of putting the device into reset state. They are External reset and Watchdog reset.

### External Reset

The device continuously samples the RST pin at state C4 of every machine cycle. Therefore the RST pin must be held for at least 2 machine cycles to ensure detection of a valid RST high. The reset circuitry then synchronously applies the internal reset signal. Thus the reset is a synchronous operation and requires the clock to be running to cause an external reset.

Once the device is in reset condition, it will remain so as long as RST is 1. Even after RST is deactivated, the device will continue to be in reset state for up to two machine cycles, and then begin program execution from 0000h. There is no flag associated with the external reset condition. However since the other two reset sources have flags, the external reset can be considered as the default reset if those two flags are cleared.

The software must clear the POR flag after reading it, otherwise it will not be possible to correctly determine future reset sources. If the power fails, i.e. falls below  $V_{rst}$ , then the device will once again go into reset state. When the power returns to the proper operating levels, the device will again perform a power on reset delay and set the POR flag.

### Watchdog Timer Reset

The Watchdog timer is a free running timer with programmable time-out intervals. The user can clear the watchdog timer at any time, causing it to restart the count. When the time-out interval is reached an interrupt flag is set. If the Watchdog reset is enabled and the watchdog timer is not cleared, then 512 clocks from the flag being set, the watchdog timer will generate a reset. This places the device into the reset condition. The reset condition is maintained by hardware for two machine cycles. Once the reset is removed the device will begin execution from 0000h.



## Reset State

Most of the SFRs and registers on the device will go to the same condition in the reset state. The Program Counter is forced to 0000h and is held there as long as the reset condition is applied. However, the reset state does not affect the on-chip RAM. The data in the RAM will be preserved during the reset. However, the stack pointer is reset to 07h, and therefore the stack contents will be lost. The RAM contents will be lost if the  $V_{DD}$  falls below approximately 2V, as this is the minimum voltage level required for the RAM to operate normally. Therefore after a first time power on reset the RAM contents will be indeterminate. During a power fail condition, if the power falls below 2V, the RAM contents are lost.

After a reset most SFRs are cleared. Interrupts and Timers are disabled. The Watchdog timer is disabled if the reset source was a POR. The port SFRs have FFh written into them which puts the port pins in a high state. Port 0 floats as it does not have on-chip pull-ups.

**Table 6. SFR Reset Value**

SFR Name	Reset Value	SFR Name	Reset Value
P0	11111111b	IE	00000000b
SP	0000111b	SADDR	00000000b
DPL	00000000b	P3	11111111b
DPH	00000000b	IP	x0000000b
PMR	010xx0x0b	SADEN	00000000b
STATUS	000x0000b	T2CON	00000000b
PC	00000000b	T2MOD	0000x00b
PCON	00xx0000b	RCAP2L	00000000b
TCON	00000000b	RCAP2H	00000000b
TMOD	00000000b	TL2	00000000b
TL0	00000000b	TH2	00000000b
TL1	00000000b	TA	11111111b
TH0	00000000b	PSW	00000000b
TH1	00000000b	WDCON	0x0x0xx0b
CKCON	0000001b	ACC	00000000b
P1	11111111b	EIE	xxx00000b
P4CONA	00000000b	P4CONB	00000000b
P40AL	00000000b	P40AH	00000000b
P41AL	00000000b	P41AH	00000000b
P42AL	00000000b	P42AH	00000000b
P43AI	00000000b	P43AH	00000000b
CHPCON	00000000b	P4CSIN	00000000b
ROMCON	0000111b	SFRAL	00000000b
SFRAH	00000000b	SFRFD	00000000b
SFRCN	00111111b	P4	xxxx1111b



Table 6. SFR Reset Value, continued

SFR Name	Reset Value	SFR Name	Reset Value
SCON	00000000b	B	00000000b
SBUF	xxxxxxx0b	EIP	xxx00000b
P2	11111111b	PWMCON1	00000000b
PWMCON2	00000000b	PWM0	00000000b
PWM1	00000000b	PWM2	00000000b
PWM3	00000000b	PWM4	00000000b
PWM5	00000000b		

The WDCON SFR bits are set/cleared in reset condition depending on the source of the reset.

	External reset	Watchdog reset	Power on reset
WDCON	0x0x0x0b	0x0x01x0b	01000000b

The POR bit WDCON.6 is set only by the power on reset. The WTRF bit WDCON.2 is set when the Watchdog timer causes a reset. A power on reset will also clear this bit. The EWT bit WDCON.1 is cleared by power on resets. This disables the Watchdog timer resets. A watchdog or external reset does not affect the EWT bit.

## 9. INTERRUPTS

The W79E648 has a two priority level interrupt structure with 11 interrupt sources. Each of the interrupt sources has an individual priority bit, flag, interrupt vector and enable bit. In addition, the interrupts can be globally enabled or disabled.

### Interrupt Sources

The External Interrupts  $\overline{INT0}$  and  $\overline{INT1}$  can be either edge triggered or level triggered, depending on bits IT0 and IT1. The bits IE0 and IE1 in the TCON register are the flags which are checked to generate the interrupt. In the edge triggered mode, the INTx inputs are sampled in every machine cycle. If the sample is high in one cycle and low in the next, then a high to low transition is detected and the interrupts request flag IEx in TCON is set. The flag bit requests the interrupt. Since the external interrupts are sampled every machine cycle, they have to be held high or low for at least one complete machine cycle. The IEx flag is automatically cleared when the service routine is called. If the level triggered mode is selected, then the requesting source has to hold the pin low till the interrupt is serviced. The IEx flag will not be cleared by the hardware on entering the service routine. If the interrupt continues to be held low even after the service routine is completed, then the processor may acknowledge another interrupt request from the same source.



The Timer 0 and 1 Interrupts are generated by the TF0 and TF1 flags. These flags are set by the overflow in the Timer 0 and Timer 1. The TF0 and TF1 flags are automatically cleared by the hardware when the timer interrupt is serviced. The Timer 2 interrupt is generated by a logical OR of the TF2 and the EXF2 flags. These flags are set by overflow or capture/reload events in the timer 2 operation. The hardware does not clear these flags when a timer 2 interrupt is executed. Software has to resolve the cause of the interrupt between TF2 and EXF2 and clear the appropriate flag.

The Watchdog timer can be used as a system monitor or a simple timer. In either case, when the time-out count is reached, the Watchdog timer interrupt flag WDIF (WDCON.3) is set. If the interrupt is enabled by the enable bit EIE.4, then an interrupt will occur.

All the bits that generate interrupts can be set or reset by hardware, and thereby software initiated interrupts can be generated. Each of the individual interrupts can be enabled or disabled by setting or clearing a bit in the IE SFR. IE also has a global enable/disable bit EA, which can be cleared to disable all the interrupts.

## Priority Level Structure

There are three priority levels for the interrupts, highest, high and low. The interrupt sources can be individually set to either high or low levels. Naturally, a higher priority interrupt cannot be interrupted by a lower priority interrupt. However there exists a pre-defined hierarchy amongst the interrupts themselves. This hierarchy comes into play when the interrupt controller has to resolve simultaneous requests having the same priority level. This hierarchy is defined as shown below; the interrupts are numbered starting from the highest priority to the lowest.

**Table 7. Priority structure of interrupts**

Source	Flag	Vector Address	Priority level
External Interrupt 0	IE0	0003h	1 (highest)
Timer 0 Overflow	TF0	000Bh	2
External Interrupt 1	IE1	0013h	3
Timer 1 Overflow	TF1	001Bh	4
Serial Port	RI + TI	0023h	5
Timer 2 Overflow	TF2 + EXF2	002Bh	6
Watchdog Timer	WDIF	0063h	7 (lowest)



## 10. PROGRAMMABLE TIMERS/COUNTERS

The W79E648 has three 16-bit programmable timer/counters and one programmable Watchdog timer. The Watchdog timer is operationally quite different from the other two timers.

### 10.1 Timer/Counters 0 & 1

The W79E648 has two 16-bit Timer/Counters. Each of these Timer/Counters has two 8 bit registers which form the 16 bit counting register. For Timer/Counter 0 they are TH0, the upper 8 bits register, and TL0, the lower 8 bit register. Similarly Timer/Counter 1 has two 8 bit registers, TH1 and TL1. The two can be configured to operate either as timers, counting machine cycles or as counters counting external inputs.

When configured as a "Timer", the timer counts clock cycles. The timer clock can be programmed to be thought of as 1/12 of the system clock or 1/4 of the system clock. In the "Counter" mode, the register is incremented on the falling edge of the external input pin, T0 in case of Timer 0, and T1 for Timer 1. The T0 and T1 inputs are sampled in every machine cycle at C4. If the sampled value is high in one machine cycle and low in the next, then a valid high to low transition on the pin is recognized and the count register is incremented. Since it takes two machine cycles to recognize a negative transition on the pin, the maximum rate at which counting will take place is 1/24 of the master clock frequency. In either the "Timer" or "Counter" mode, the count register will be updated at C3. Therefore, in the "Timer" mode, the recognized negative transition on pin T0 and T1 can cause the count register value to be updated only in the machine cycle following the one in which the negative edge was detected.

The "Timer" or "Counter" function is selected by the "C/ $\bar{T}$ " bit in the TMOD Special Function Register. Each Timer/Counter has one selection bit for its own; bit 2 of TMOD selects the function for Timer/Counter 0 and bit 6 of TMOD selects the function for Timer/Counter 1. In addition each Timer/Counter can be set to operate in any one of four possible modes. The mode selection is done by bits M0 and M1 in the TMOD SFR.

#### Time-Base Selection

The W79E648 gives the user two modes of operation for the timer. The timers can be programmed to operate like the standard 8051 family, counting at the rate of 1/12 of the clock speed. This will ensure that timing loops on the W79E648 and the standard 8051 can be matched. This is the default mode of operation of the W79E648 timers. The user also has the option to count in the turbo mode, where the timers will increment at the rate of 1/4 clock speed. This will straight-away increase the counting speed three times. This selection is done by the T0M and T1M bits in CKCON SFR. A reset sets these bits to 0, and the timers then operate in the standard 8051 mode. The user should set these bits to 1 if the timers are to operate in turbo mode.

#### Mode 0

In Mode 0, the timer/counters act as a 8 bit counter with a 5 bit, divide by 32 pre-scale. In this mode we have a 13 bit timer/counter. The 13 bit counter consists of 8 bits of THx and 5 lower bits of TLx. The upper 3 bits of TLx are ignored.

The negative edge of the clock increments the count in the TLx register. When the fifth bit in TLx moves from 1 to 0, then the count in the THx register is incremented. When the count in THx moves from FFh to 00h, then the overflow flag TFx in TCON SFR is set. The counted input is enabled only if



TRx is set and either GATE = 0 or  $\overline{\text{INTx}} = 1$ . When C/ $\overline{\text{T}}$  is set to 0, then it will count clock cycles, and if C/ $\overline{\text{T}}$  is set to 1, then it will count 1 to 0 transitions on T0 (P3.4) for timer 0 and T1 (P3.5) for timer 1. When the 13 bit count reaches 1FFFh the next count will cause it to roll-over to 0000h. The timer overflow flag TFx of the relevant timer is set and if enabled an interrupts will occur. Note that when used as a timer, the time-base may be either clock cycles/12 or clock cycles/4 as selected by the bits TxM of the CKCON SFR.

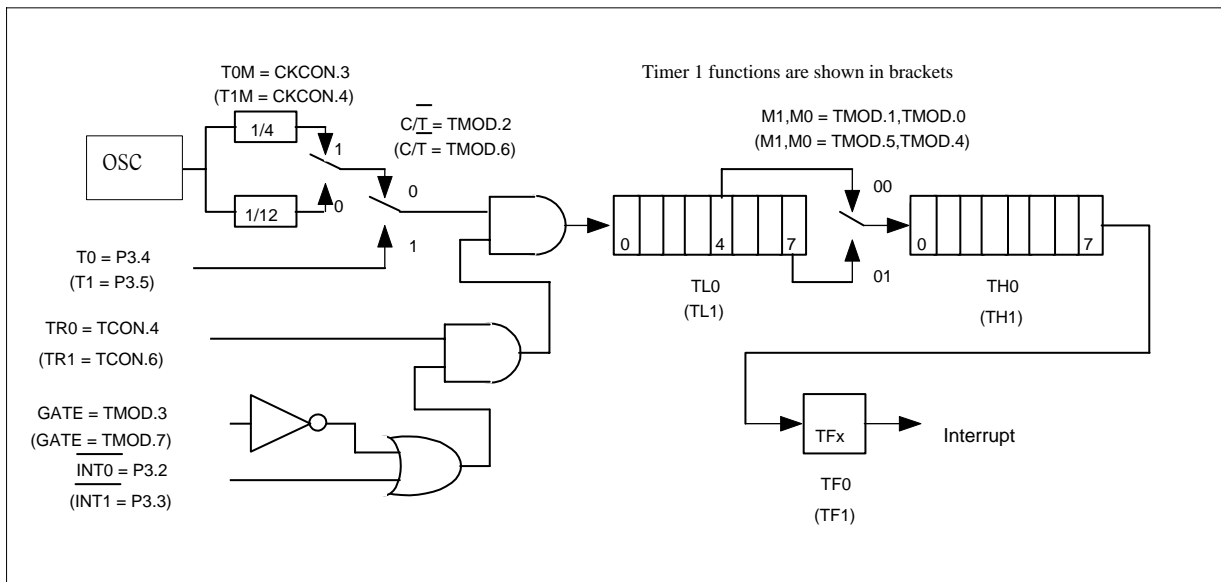

## Mode 1

Mode 1 is similar to Mode 0 except that the counting register forms a 16 bit counter, rather than a 13 bit counter. This means that all the bits of THx and TLx are used. Roll-over occurs when the timer moves from a count of FFFFh to 0000h. The timer overflow flag TFx of the relevant timer is set and if enabled an interrupt will occur. The selection of the time-base in the timer mode is similar to that in Mode 0. The gate function operates similarly to that in Mode 0.

## Mode 2

In Mode 2, the timer/counter is in the Auto Reload Mode. In this mode, TLx acts as a 8 bit count register, while THx holds the reload value. When the TLx register overflows from FFh to 00h, the TFx bit in TCON is set and TLx is reloaded with the contents of THx, and the counting process continues from here. The reload operation leaves the contents of the THx register unchanged. Counting is enabled by the TRx bit and proper setting of GATE and  $\overline{\text{INTx}}$  pins. As in the other two modes 0 and 1 mode 2 allows counting of either clock cycles (clock/12 or clock/4) or pulses on pin Tn.

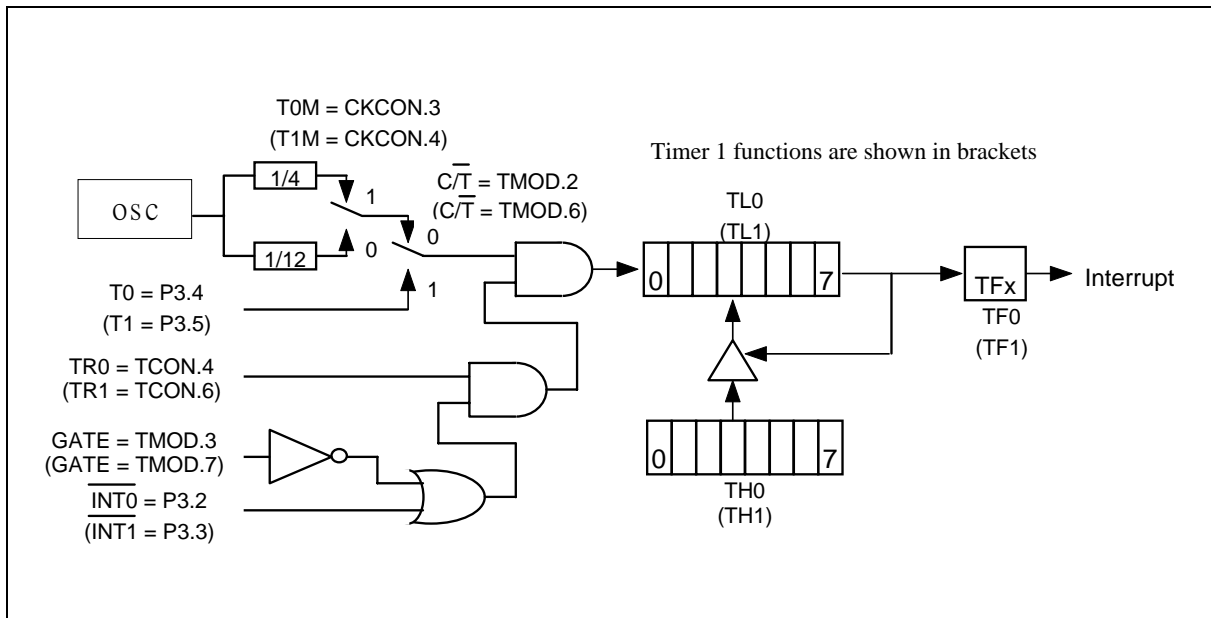

## Mode 3

Mode 3 has different operating methods for the two timer/counters. For timer/counter 1, mode 3 simply freezes the counter. Timer/Counter 0, however, configures TL0 and TH0 as two separate 8 bit count registers in this mode. The logic for this mode is shown in the figure. TL0 uses the Timer/Counter 0 control bits  $C/\bar{T}$ , GATE, TR0,  $\overline{INT0}$  and TF0. The TL0 can be used to count clock cycles (clock/12 or clock/4) or 1-to-0 transitions on pin T0 as determined by C/T (TMOD.2). TH0 is forced as a clock cycle counter (clock/12 or clock/4) and takes over the use of TR1 and TF1 from Timer/Counter 1. Mode 3 is used in cases where an extra 8 bit timer is needed. With Timer 0 in Mode 3, Timer 1 can still be used in Modes 0, 1 and 2., but its flexibility is somewhat limited. While its basic functionality is maintained, it no longer has control over its overflow flag TF1 and the enable bit TR1. Timer 1 can still be used as a timer/counter and retains the use of GATE and INT1 pin. In this condition it can be turned on and off by switching it out of and into its own Mode 3. It can also be used as a baud rate generator for the serial port.

## 10.2 Timer/Counter 2

Timer/Counter 2 is a 16 bit up/down counter which is configured by the T2MOD register and controlled by the T2CON register. Timer/Counter 2 is equipped with a capture/reload capability. As with the Timer 0 and Timer 1 counters, there exists considerable flexibility in selecting and controlling the clock, and in defining the operating mode. The clock source for Timer/Counter 2 may be selected for either the external T2 pin ( $C/T2 = 1$ ) or the crystal oscillator, which is divided by 12 or 4 ( $C/T2 = 0$ ). The clock is then enabled when TR2 is a 1, and disabled when TR2 is a 0.

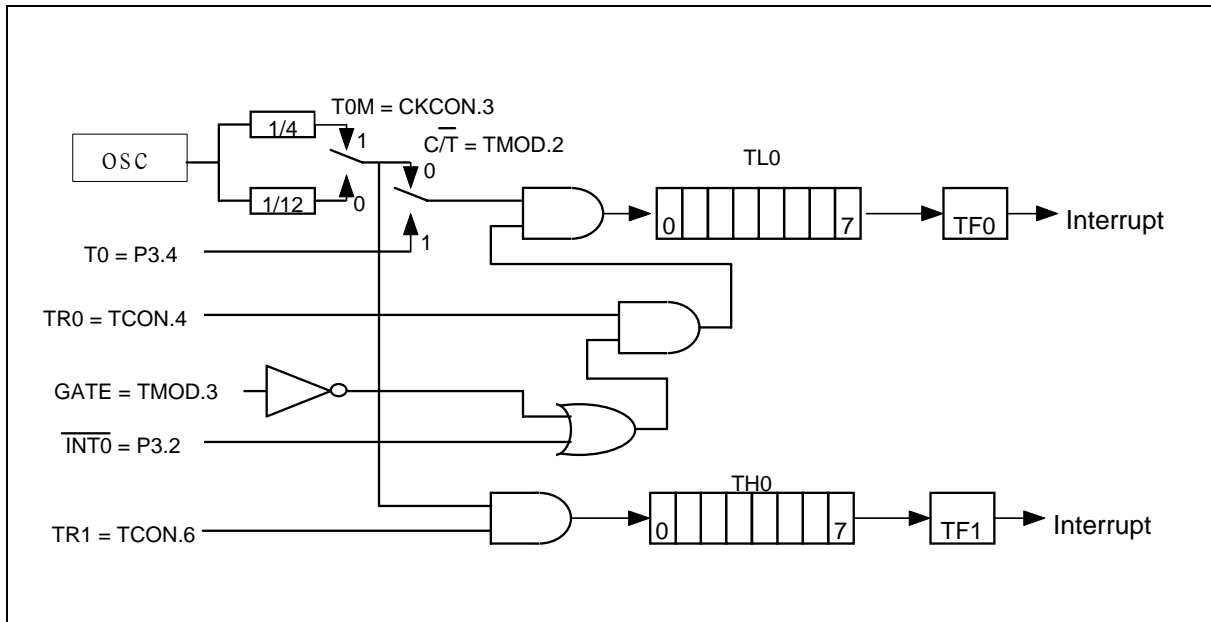

Figure 13. Timer/Counter 0 Mode 3

### Capture Mode

The capture mode is enabled by setting the  $CP / \overline{RL2}$  bit in the T2CON register to a 1. In the capture mode, Timer/Counter 2 serves as a 16 bit up counter. When the counter rolls over from FFFFh to 0000h, the TF2 bit is set, which will generate an interrupt request. If the EXEN2 bit is set, then a negative transition of T2EX pin will cause the value in the TL2 and TH2 register to be captured by the RCAP2L and RCAP2H registers. This action also causes the EXF2 bit in T2CON to be set, which will also generate an interrupt. Setting the T2CR bit (T2MOD.3), the W79E648 allows hardware to reset timer 2 automatically after the value of TL2 and TH2 have been captured.

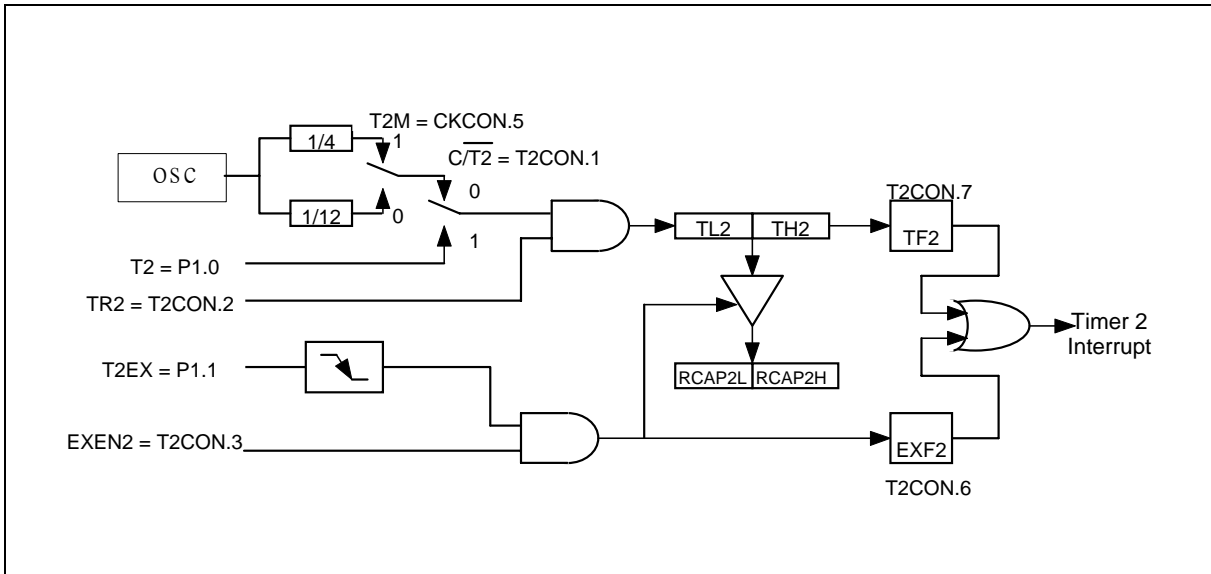

Figure 14. 16-Bit Capture Mode

**Auto-reload Mode, Counting up**

The auto-reload mode as an up counter is enabled by clearing the  $CP / \overline{RL2}$  bit in the T2CON register and clearing the DCEN bit in T2MOD register. In this mode, Timer/Counter 2 is a 16 bit up counter. When the counter rolls over from FFFFh, a reload is generated that causes the contents of the RCAP2L and RCAP2H registers to be reloaded into the TL2 and TH2 registers. The reload action also sets the TF2 bit. If the EXEN2 bit is set, then a negative transition of T2EX pin will also cause a reload. This action also sets the EXF2 bit in T2CON.

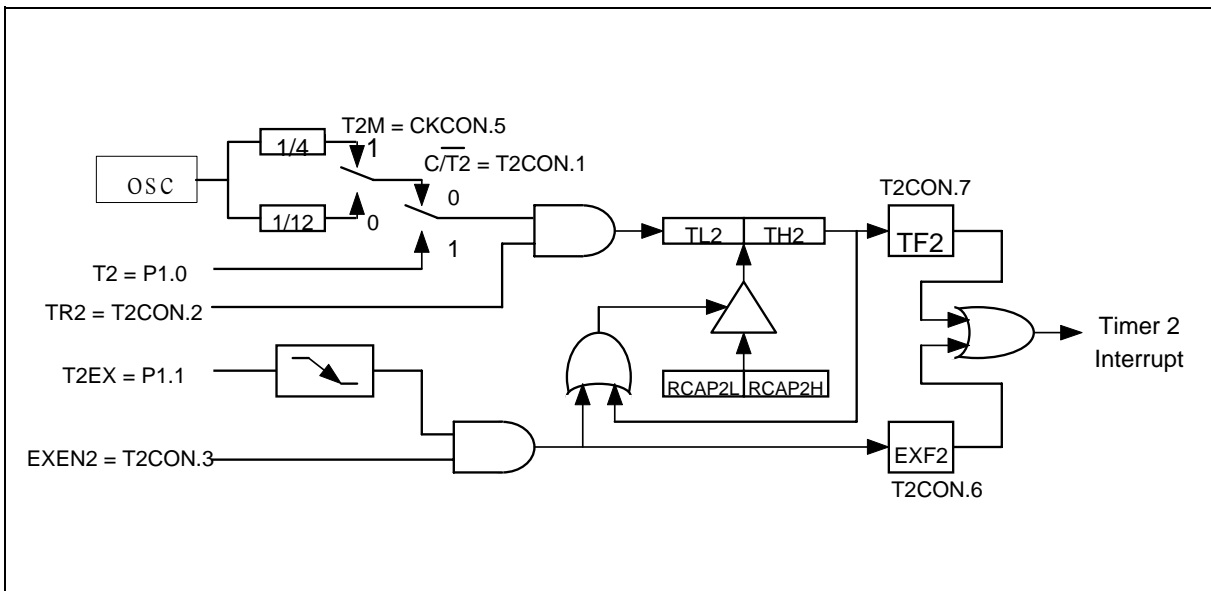

Figure 15. 16-Bit Auto-reload Mode, Counting Up



## Auto-reload Mode, Counting Up/Down

Timer/Counter 2 will be in auto-reload mode as an up/down counter if  $\overline{CP}/\overline{RL2}$  bit in T2CON is cleared and the DCEN bit in T2MOD is set. In this mode, Timer/Counter 2 is an up/down counter whose direction is controlled by the T2EX pin. A 1 on this pin cause the counter to count up. An overflow while counting up will cause the counter to be reloaded with the contents of the capture registers. The next down count following the case where the contents of Timer/Counter equal the capture registers will load an FFFFh into Timer/Counter 2. In either event a reload will set the TF2 bit. A reload will also toggle the EXF2 bit. However, the EXF2 bit can not generate an interrupt while in this mode.

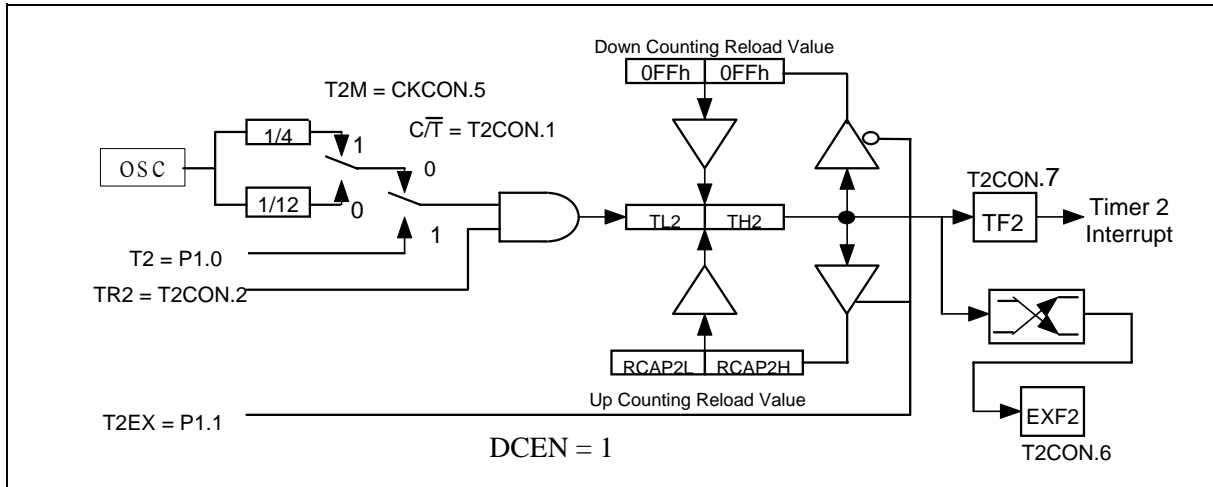

Figure 16. 16-Bit Auto-reload Up/Down Counter

## Baud Rate Generator Mode

The baud rate generator mode is enabled by setting either the RCLK or TCLK bits in T2CON register. While in the baud rate generator mode, Timer/Counter 2 is a 16 bit counter with auto reload when the count rolls over from FFFFh. However, rolling over does not set the TF2 bit. If EXEN2 bit is set, then a negative transition of the T2EX pin will set EXF2 bit in the T2CON register and cause an interrupt request.

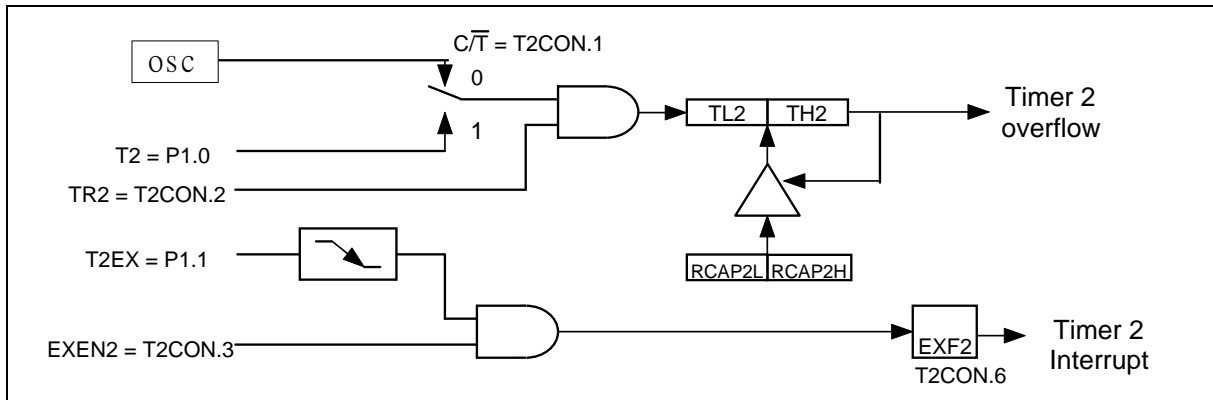

Figure 17. Baud Rate Generator Mode



## 10.3 Pulse Width Modulated Outputs (PWM)

There are six pulse width modulated output channels to generate pulses of programmable length and interval. The repetition frequency is defined by an 8-bit prescaler PWMP, which supplies the clock for the counter. The prescaler and counter are common to both PWM channels. The 8-bit counter counts modular 255 (0 ~ 254). The value of the 8-bit counter compared to the contents of six registers: PWM0, PWM1, PWM2, PWM3 and PWM4. Provided the contents of either these registers is greater than the counter value, the corresponding PWM0, PWM1, PWM2, PWM3, PWM4 or PWM5 output is set HIGH. If the contents of these registers are equal to, or less than the counter value, the output will be LOW. The pulse-width-ratio is defined by the contents of the registers PWM0, PWM1, PWM2, PWM3, PWM4 and PWM5. The pulse-width-ratio is in the range of 0 to 1 and may be programmed in increments of 1/255. ENPWM0, ENPWM1, ENPWM2, ENPWM3, ENPWM4 and ENPWM5 bit will enable or disable PWM output.

Buffered PWM outputs may be used to drive DC motors. The rotation speed of the motor would be proportional to the contents of PWM0/1/2/3/4/5. The repetition frequency  $f_{pwm}$ , at the PWM0/1/2/3/4/5 output is given by:

$$f_{pwm} = \frac{f_{osc}}{2 \times (1 + PWMP) \times 255}$$

Prescaler division factor = PWM + 1

$$\text{PWMn high/low ratio of PWMn} = \frac{(\text{PWMn})}{255 - (\text{PWMn})}$$

This gives a repetition frequency range of 123 Hz to 31.4K Hz ( $f_{osc} = 16\text{M Hz}$ ). By loading the PWM registers with either 00H or FFH, the PWM channels will output a constant HIGH or LOW level, respectively. Since the 8-bit counter counts modulo 255, it can never actually reach the value of the PWM registers when they are loaded with FFH.

When a compare register (PWM0, PWM1, PWM2, PWM3, PWM4, PWM5) is loaded with a new value, the associated output updated immediately. It does not have to wait until the end of the current counter period. There is weakly pulled high on PWM output.

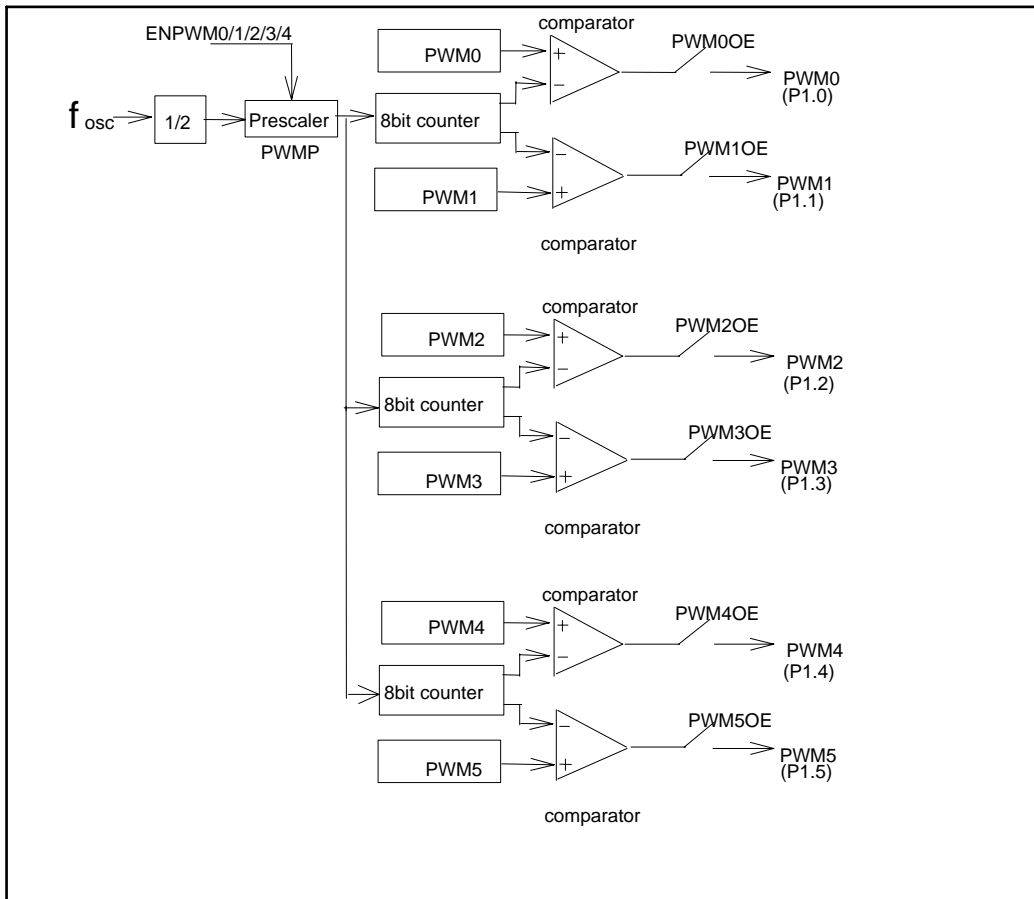

**FIGURE 1 PWM DIAGRAM**

Please refer as below code.

```

mov  pwmcon1, #00110011b      ; enable pwm3, 2, 1, 0
mov  pwmcon2, #00000101b      ; enable pwm4
mov  pwmp, #40h                ; Fpwm = XT/(2*(1+pwmp)*255)
mov  pwm0, #14h                ; duty cycle high/low = pwm0/(255-pmw0)
mov  pwm1, #18h
mov  pwm2, #20h
mov  pwm3, #b0h
mov  pwm4, #40h
mov  pwmcon1, #11111111b      ; output enable pwm3, 2, 1, 0
    
```





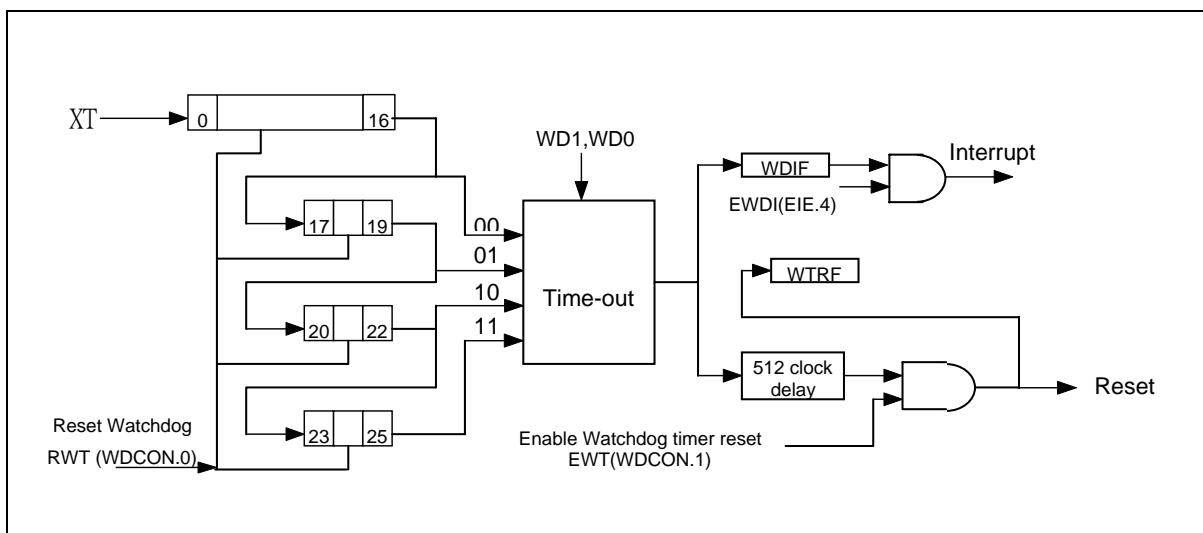

Figure 19. Watchdog Timer

The Watchdog timer should first be restarted by using RWT. This ensures that the timer starts from a known state. The RWT bit is used to restart the watchdog timer. This bit is self clearing, i.e. after writing a 1 to this bit the software will automatically clear it. The watchdog timer will now count clock cycles. The time-out interval is selected by the two bits WD1 and WD0 (CKCON.7 and CKCON.6). When the selected time-out occurs, the Watchdog interrupt flag WDIF (WDCON.3) is set. After the time-out has occurred, the watchdog timer waits for an additional 512 clock cycles. If the Watchdog Reset EWT (WDCON.1) is enabled, then 512 clocks after the time-out, if there is no RWT, a system reset due to Watchdog timer will occur. This will last for two machine cycles, and the Watchdog timer reset flag WTRF (WDCON.2) will be set. This indicates to the software that the watchdog was the cause of the reset.

When used as a simple timer, the reset and interrupt functions are disabled. The timer will set the WDIF flag each time the timer completes the selected time interval. The WDIF flag is polled to detect a time-out and the RWT allows software to restart the timer. The Watchdog timer can also be used as a very long timer. The interrupt feature is enabled in this case. Every time the time-out occurs an interrupt will occur if the global interrupt enable EA is set.

The main use of the Watchdog timer is as a system monitor. This is important in real-time control applications. In case of some power glitches or electro-magnetic interference, the processor may begin to execute errant code. If this is left unchecked the entire system may crash. Using the watchdog timer interrupt during software development will allow the user to select ideal watchdog reset locations. The code is first written without the watchdog interrupt or reset. Then the watchdog interrupt is enabled to identify code locations where interrupt occurs. The user can now insert instructions to reset the watchdog timer which will allow the code to run without any watchdog timer interrupts. Now the watchdog timer reset is enabled and the watchdog interrupt may be disabled. If any errant code is executed now, then the reset watchdog timer instructions will not be executed at the required instants and watchdog reset will occur.

The watchdog time-out selection will result in different time-out values depending on the clock speed. The reset, when enabled, will occur 512 clocks after the time-out has occurred.



**Table 9. Time-out values for the Watchdog timer**

WD1	WD0	Watchdog Interval	Number of Clocks	Time @ 1.8432 MHz	Time @ 10 MHz	Time @ 25 MHz
0	0	$2^{17}$	131072	71.11 mS	13.11 mS	5.24 mS
0	1	$2^{20}$	1048576	568.89 mS	104.86 mS	41.94 mS
1	0	$2^{23}$	8388608	4551.11 mS	838.86 mS	335.54 mS
1	1	$2^{26}$	67108864	36408.88 mS	6710.89 mS	2684.35 mS

The Watchdog timer will be disabled by a power-on/fail reset. The Watchdog timer reset does not disable the watchdog timer, but will restart it. In general, software should restart the timer to put it into a known state.

The control bits that support the Watchdog timer are discussed below.

## Watchdog Control

- WDIF: WDCON.3 - Watchdog Timer Interrupt flag. This bit is set whenever the time-out occurs in the watchdog timer. If the Watchdog interrupt is enabled (EIE.4), then an interrupt will occur (if the global interrupt enable is set and other interrupt requirements are met). Software or any reset can clear this bit.
- WTRF: WDCON.2 - Watchdog Timer Reset flag. This bit is set whenever a watchdog reset occurs. This bit is useful for determining the cause of a reset. Software must read it, and clear it manually. A Power-fail reset will clear this bit. If EWT = 0, then this bit will not be affected by the watchdog timer.
- EWT: WDCON.1 - Enable Watchdog timer Reset. This bit when set to 1 will enable the Watchdog timer reset function. Setting this bit to 0 will disable the Watchdog timer reset function, but will leave the timer running.
- RWT: WDCON.0 - Reset Watchdog Timer. This bit is used to clear the Watchdog timer and to restart it. This bit is self-clearing, so after the software writes 1 to it the hardware will automatically clear it. If the Watchdog timer reset is enabled, then the RWT has to be set by the user within 512 clocks of the time-out. If this is not done then a Watchdog timer reset will occur.



## Clock Control

WD1, WD0: CKCON.7, CKCON.6 - Watchdog Timer Mode select bits. These two bits select the time-out interval for the watchdog timer. The reset time is 512 clock longer than the interrupt time-out value.

The default Watchdog time-out is  $2^{17}$  clocks, which is the shortest time-out period. The EWT, WDIF and RWT bits are protected by the Timed Access procedure. This prevents software from accidentally enabling or disabling the watchdog timer. More importantly, it makes it highly improbable that errant code can enable or disable the watchdog timer. Please refer as below demo program.

```
org    63h
mov    TA,#AAH
mov    TA,#55H
clr    WDIF
jnb    execute_reset_flag,bypass_reset    ; Test if CPU need to reset.
jmp    $                                   ; Wait to reset

bypass_reset:
mov    TA,#AAH
mov    TA,#55H
setb   RWT
reti

org    300h
start:
mov    ckcon,#01h    ; select 2 ^ 17 timer
; mov    ckcon,#61h    ; select 2 ^ 20 timer
; mov    ckcon,#81h    ; select 2 ^ 23 timer
; mov    ckcon,#c1h    ; select 2 ^ 26 timer
mov    TA,#aah
mov    TA,#55h
mov    WDCON,#00000011B
setb   EWDI
setb   ea
jmp    $             ; wait time out
```



## 11. SERIAL PORT

Serial port in the W79E648 is a full duplex port. The W79E648 provides the user with additional features such as the Frame Error Detection and the Automatic Address Recognition. The serial ports are capable of synchronous as well as asynchronous communication. In Synchronous mode the W79E648 generates the clock and operates in a half duplex mode. In the asynchronous mode, full duplex operation is available. This means that it can simultaneously transmit and receive data. The transmit register and the receive buffer are both addressed as SBUF Special Function Register. However any write to SBUF will be to the transmit register, while a read from SBUF will be from the receive buffer register. The serial port can operate in four different modes as described below.

### Mode 0

This mode provides synchronous communication with external devices. In this mode serial data is transmitted and received on the RXD line. TXD is used to transmit the shift clock. The TxD clock is provided by the W79E648 whether the device is transmitting or receiving. This mode is therefore a half duplex mode of serial communication. In this mode, 8 bits are transmitted or received per frame. The LSB is transmitted/received first. The baud rate is fixed at 1/12 or 1/4 of the oscillator frequency. This baud rate is determined by the SM2 bit (SCON.5). When this bit is set to 0, then the serial port runs at 1/12 of the clock. When set to 1, the serial port runs at 1/4 of the clock. This additional facility of programmable baud rate in mode 0 is the only difference between the standard 8051 and the W79E648.

The functional block diagram is shown below. Data enters and leaves the Serial port on the RxD line. The TxD line is used to output the shift clock. The shift clock is used to shift data into and out of the W79E648 and the device at the other end of the line. Any instruction that causes a write to SBUF will start the transmission. The shift clock will be activated and data will be shifted out on the RxD pin till all 8 bits are transmitted. If SM2 = 1, then the data on RxD will appear 1 clock period before the falling edge of shift clock on TxD. The clock on TxD then remains low for 2 clock periods, and then goes high again. If SM2 = 0, the data on RxD will appear 3 clock periods before the falling edge of shift clock on TxD. The clock on TxD then remains low for 6 clock periods, and then goes high again. This ensures that at the receiving end the data on RxD line can either be clocked on the rising edge of the shift clock on TxD or latched when the TxD clock is low.





The 16 states of the counter effectively divide the bit time into 16 slices. The bit detection is done on a best of three basis. The bit detector samples the RxD pin, at the 8th, 9th and 10th counter states. By using a majority 2 of 3 voting system, the bit value is selected. This is done to improve the noise rejection feature of the serial port. If the first bit detected after the falling edge of RxD pin is not 0, then this indicates an invalid start bit, and the reception is immediately aborted. The serial port again looks for a falling edge in the RxD line. If a valid start bit is detected, then the rest of the bits are also detected and shifted into the SBUF.

After shifting in 8 data bits, there is one more shift to do, after which the SBUF and RB8 are loaded and RI is set. However certain conditions must be met before the loading and setting of RI can be done.

1. RI must be 0 and
2. Either SM2 = 0, or the received stop bit = 1.

If these conditions are met, then the stop bit goes to RB8, the 8 data bits go into SBUF and RI is set. Otherwise the received frame may be lost. After the middle of the stop bit, the receiver goes back to looking for a 1-to-0 transition on the RxD pin.

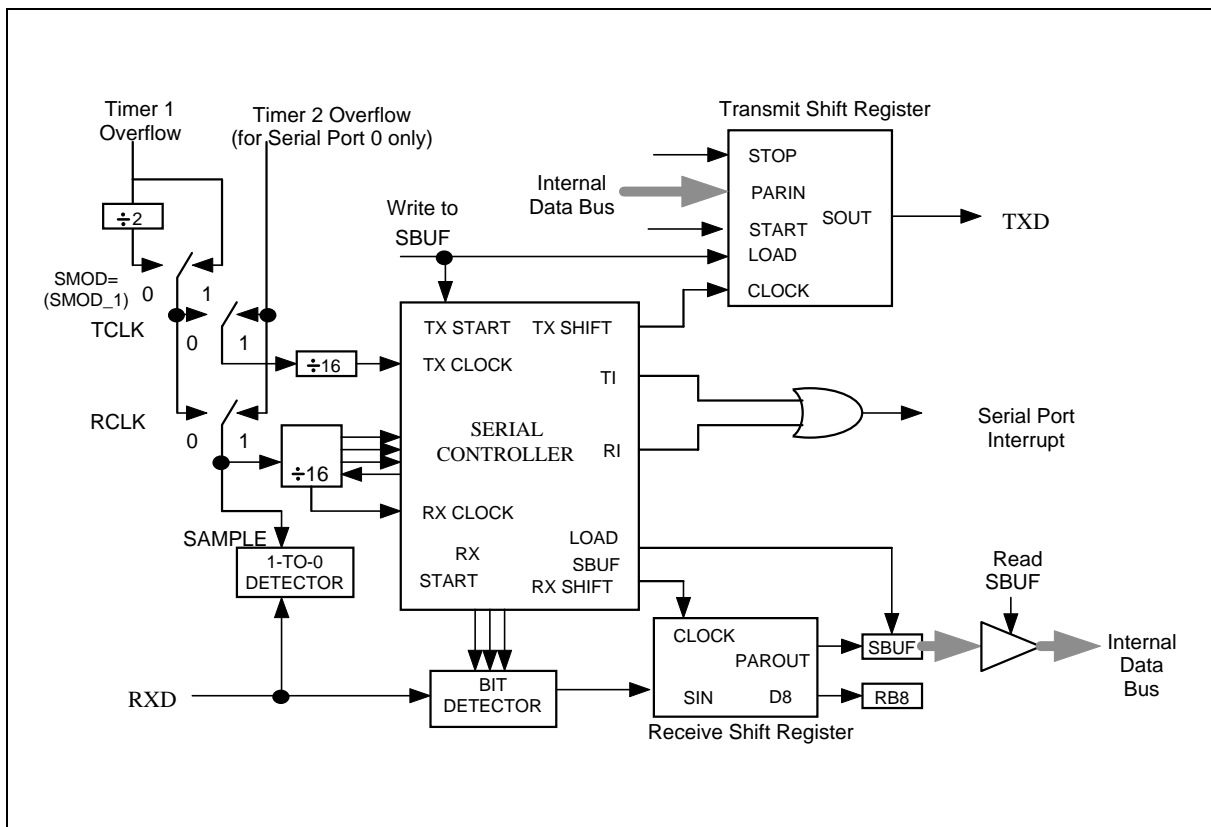

Figure 21. Serial Port Mode 1



## Mode 2

This mode uses a total of 11 bits in asynchronous full-duplex communication. The functional description is shown in the figure below. The frame consists of one start bit (0), 8 data bits (LSB first), a programmable 9th bit (TB8) and a stop bit (0). The 9th bit received is put into RB8. The baud rate is programmable to 1/32 or 1/64 of the oscillator frequency, which is determined by the SMOD bit in PCON SFR. Transmission begins with a write to SBUF. The serial data is brought out on to TxD pin at C1 following the first roll-over of the divide by 16 counter. The next bit is placed on TxD pin at C1 following the next rollover of the divide by 16 counter. Thus the transmission is synchronized to the divide by 16 counter, and not directly to the write to SBUF signal. After all 9 bits of data are transmitted, the stop bit is transmitted. The TI flag is set in the C1 state after the stop bit has been put out on TxD pin. This will be at the 11th rollover of the divide by 16 counter after a write to SBUF. Reception is enabled only if REN is high. The serial port actually starts the receiving of serial data, with the detection of a falling edge on the RxD pin. The 1-to-0 detector continuously monitors the RxD line, sampling it at the rate of 16 times the selected baud rate. When a falling edge is detected, the divide by 16 counter is immediately reset. This helps to align the bit boundaries with the rollovers of the divide by 16 counter. The 16 states of the counter effectively divide the bit time into 16 slices. The bit detection is done on a best of three basis. The bit detector samples the RxD pin, at the 8th, 9th and 10th counter states. By using a majority 2 of 3 voting system, the bit value is selected. This is done to improve the noise rejection feature of the serial port.

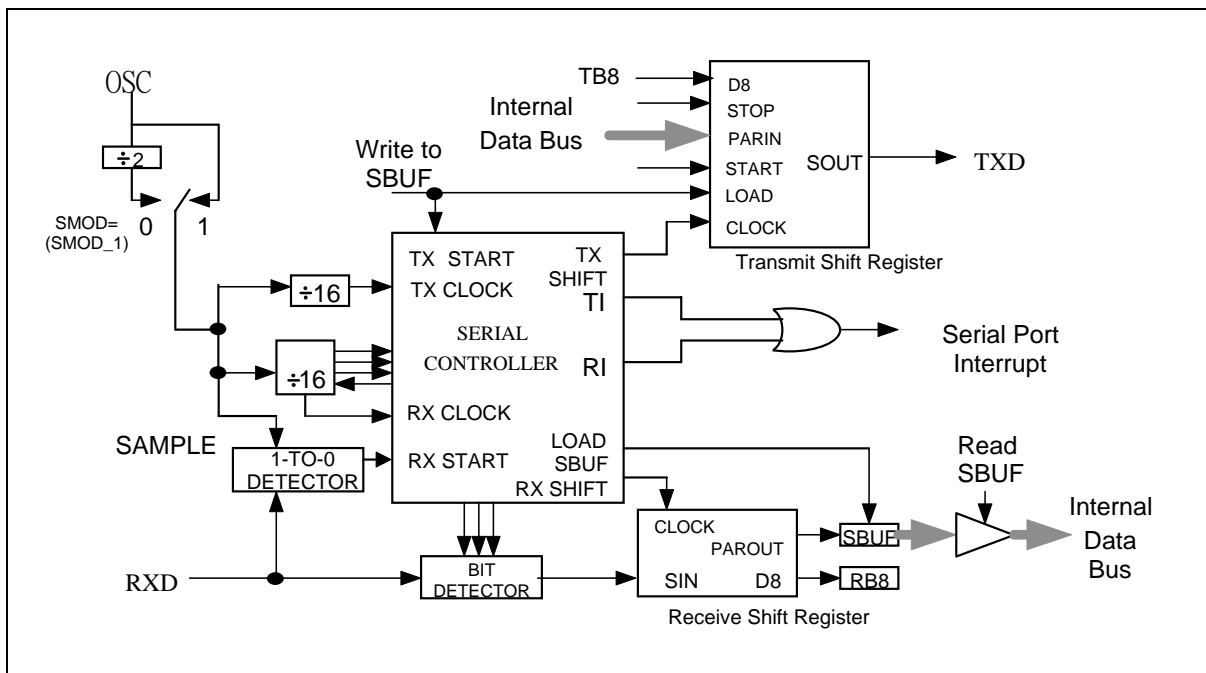

Figure 22. Serial Port Mode 2

If the first bit detected after the falling edge of RxD pin, is not 0, then this indicates an invalid start bit, and the reception is immediately aborted. The serial port again looks for a falling edge in the RxD line. If a valid start bit is detected, then the rest of the bits are also detected and shifted into the SBUF. After shifting in 9 data bits, there is one more shift to do, after which the SBUF and RB8 are loaded

## Preliminary W79E648



and RI is set. However certain conditions must be met before the loading and setting of RI can be done.

# Preliminary W79E648



1. RI must be 0 and
2. Either SM2 = 0, or the received stop bit = 1.

If these conditions are met, then the stop bit goes to RB8, the 8 data bits go into SBUF and RI is set. Otherwise the received frame may be lost. After the middle of the stop bit, the receiver goes back to looking for a 1-to-0 transition on the RxD pin.

### Mode 3

This mode is similar to Mode 2 in all respects, except that the baud rate is programmable. The user must first initialize the Serial related SFR SCON before any communication can take place. This involves selection of the Mode and baud rate. The Timer 1 should also be initialized if modes 1 and 3 are used. In all four modes, transmission is started by any instruction that uses SBUF as a destination register. Reception is initiated in Mode 0 by the condition RI = 0 and REN = 1. This will generate a clock on the TxD pin and shift in 8 bits on the RxD pin. Reception is initiated in the other modes by the incoming start bit if REN = 1. The external device will start the communication by transmitting the start bit.

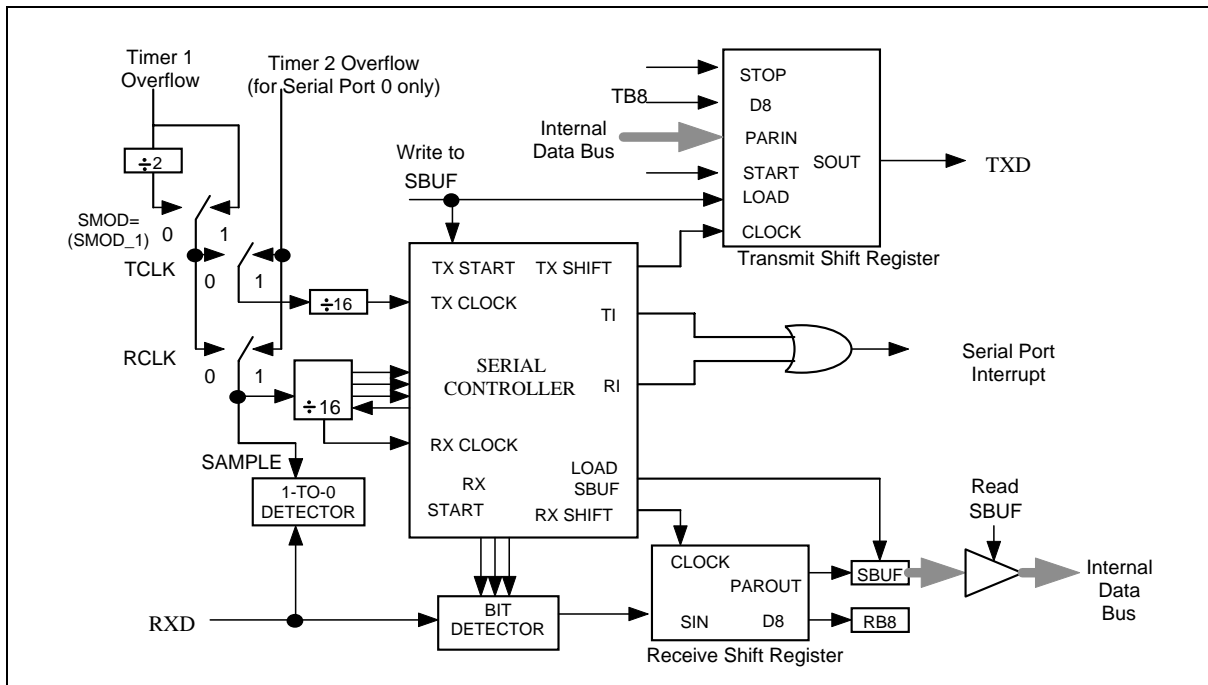

Figure 23. Serial Port Mode 3

Table 10. Serial Ports Modes

SM1	SM0	Mode	Type	Baud Clock	Frame Size	Start Bit	Stop Bit	9th bit Function
0	0	0	Synch.	4 or 12 TCLKS	8 bits	No	No	None
0	1	1	Asynch.	Timer 1 or 2	10 bits	1	1	None
1	0	2	Asynch.	32 or 64 TCLKS	11 bits	1	1	0, 1
1	1	3	Asynch.	Timer 1 or 2	11 bits	1	1	0, 1



## 11.1 Framing Error Detection

A Frame Error occurs when a valid stop bit is not detected. This could indicate incorrect serial data communication. Typically the frame error is due to noise and contention on the serial communication line. The W79E648 has the facility to detect such framing errors and set a flag which can be checked by software.

The Frame Error FE(FE\_1) bit is located in SCON.7. This bit is normally used as SM0 in the standard 8051 family. However, in the W79E648 it serves a dual function and is called SM0/FE. There are actually two separate flags, one for SM0 and the other for FE. The flag that is actually accessed as SCON.7 is determined by SMOD0 (PCON.6) bit. When SMOD0 is set to 1, then the FE flag is indicated in SM0/FE. When SMOD0 is set to 0, then the SM0 flag is indicated in SM0/FE.

The FE bit is set to 1 by hardware but must be cleared by software. Note that SMOD0 must be 1 while reading or writing to FE. If FE is set, then any following frames received without any error will not clear the FE flag. The clearing has to be done by software.

## 11.2 Multiprocessor Communications

Multiprocessor communications makes use of the 9th data bit in modes 2 and 3. In the W79E648, the RI flag is set only if the received byte corresponds to the Given or Broadcast address. This hardware feature eliminates the software overhead required in checking every received address, and greatly simplifies the software programmer task.

In the multiprocessor communication mode, the address bytes are distinguished from the data bytes by transmitting the address with the 9th bit set high. When the master processor wants to transmit a block of data to one of the slaves, it first sends out the address of the targeted slave (or slaves). All the slave processors should have their SM2 bit set high when waiting for an address byte. This ensures that they will be interrupted only by the reception of a address byte. The Automatic address recognition feature ensures that only the addressed slave will be interrupted. The address comparison is done in hardware not software.

The addressed slave clears the SM2 bit, thereby clearing the way to receive data bytes. With SM2 = 0, the slave will be interrupted on the reception of every single complete frame of data. The unaddressed slaves will be unaffected, as they will be still waiting for their address. In Mode 1, the 9th bit is the stop bit, which is 1 in case of a valid frame. If SM2 is 1, then RI is set only if a valid frame is received and the received byte matches the Given or Broadcast address.

The Master processor can selectively communicate with groups of slaves by using the Given Address. All the slaves can be addressed together using the Broadcast Address. The addresses for each slave are defined by the SADDR and SADEN SFRs. The slave address is an 8-bit value specified in the SADDR SFR. The SADEN SFR is actually a mask for the byte value in SADDR. If a bit position in SADEN is 0, then the corresponding bit position in SADDR is don't care. Only those bit positions in SADDR whose corresponding bits in SADEN are 1 are used to obtain the Given Address. This gives the user flexibility to address multiple slaves without changing the slave address in SADDR.

The following example shows how the user can define the Given Address to address different slaves.

Slave 1:

```
SADDR 1010 0100
SADEN 1111 1010
Given  1010 0x0x
```



Slave 2:

```
SADDR 1010 0111
SADEN 1111 1001
Given  1010 0xx1
```

The Given address for slave 1 and 2 differ in the LSB. For slave 1, it is a don't care, while for slave 2 it is 1. Thus to communicate only with slave 1, the master must send an address with LSB = 0 (1010 0000). Similarly the bit 1 position is 0 for slave 1 and don't care for slave 2. Hence to communicate only with slave 2 the master has to transmit an address with bit 1 = 1 (1010 0011). If the master wishes to communicate with both slaves simultaneously, then the address must have bit 0 = 1 and bit 1 = 0. The bit 3 position is don't care for both the slaves. This allows two different addresses to select both slaves (1010 0001 and 1010 0101).

The master can communicate with all the slaves simultaneously with the Broadcast Address. This address is formed from the logical ORing of the SADDR and SADEN SFRs. The zeros in the result are defined as don't cares. In most cases the Broadcast Address is FFh. In the previous case, the Broadcast Address is (1111111X) for slave 1 and (11111111) for slave 2.

The SADDR and SADEN SFRs are located at address A9h and B9h respectively. On reset, these two SFRs are initialized to 00h. This results in Given Address and Broadcast Address being set as XXXX XXXX (i.e. all bits don't care). This effectively removes the multiprocessor communications feature, since any selectivity is disabled.

## 12. TIMED ACCESS PROTECTION

The W79E648 has several new features, like the Watchdog timer, on-chip ROM size adjustment, wait state control signal and Power on/fail reset flag, which are crucial to proper operation of the system. If left unprotected, errant code may write to the Watchdog control bits resulting in incorrect operation and loss of control. In order to prevent this, the W79E648 has a protection scheme which controls the write access to critical bits. This protection scheme is done using a timed access.

In this method, the bits which are to be protected have a timed write enable window. A write is successful only if this window is active, otherwise the write will be discarded. This write enable window is open for 3 machine cycles if certain conditions are met. After 3 machine cycles, this window automatically closes. The window is opened by writing AAh and immediately 55h to the Timed Access (TA) SFR. This SFR is located at address C7h. The suggested code for opening the timed access window is

```
TA    REG    0C7h          ;define new register TA, located at 0C7h
MOV   TA, #0AAh
MOV   TA, #055h
```

When the software writes AAh to the TA SFR, a counter is started. This counter waits for 3 machine cycles looking for a write of 55h to TA. If the second write (55h) occurs within 3 machine cycles of the first write (AAh), then the timed access window is opened. It remains open for 3 machine cycles, during which the user may write to the protected bits. Once the window closes the procedure must be repeated to access the other protected bits.



## Examples of Timed Assessing are shown below.

### Example 1: Valid access

```
MOV  TA, #0AAh    3 M/C
MOV  TA, #055h    3 M/C
MOV  WDCON, #00h  3 M/C
```

Note: M/C = Machine Cycles

### Example 2: Valid access

```
MOV  TA, #0AAh    3 M/C
MOV  TA, #055h    3 M/C
NOP                      1 M/C
SETB EWT          2 M/C
```

### Example 3: Valid access

```
MOV  TA, #0Aah    3 M/C
MOV  TA, #055h    3 M/C
ORL  WDCON, #0000010B 3M/C
```

### Example 4: Invalid access

```
MOV  TA, #0AAh    3 M/C
MOV  TA, #055h    3 M/C
NOP                      1 M/C
NOP                      1 M/C
CLR  POR          2 M/C
```

### Example 5: Invalid Access

```
MOV  TA, #0AAh    3 M/C
NOP                      1 M/C
MOV  TA, #055h    3 M/C
SETB EWT          2 M/C
```

In the first two examples, the writing to the protected bits is done before the 3 machine cycle window closes. In Example 3, however, the writing to the protected bit occurs after the window has closed, and so there is effectively no change in the status of the protected bit. In Example 4, the second write to TA occurs 4 machine cycles after the first write, therefore the timed access window is not opened at all, and the write to the protected bit fails.



## 13. H/W REBOOT MODE (BOOT FROM 4K BYTES OF LDFLASH)

The W79E648 boots from APFlash program (64K bytes) by default at the external reset. On some occasions, user can force W79E648 to boot from the LDFlash program (4K bytes) at the external reset. The settings for this special mode is as follow. It is necessary to add 10K resistor on these P2.6, P2.7 and P4.3 pins.

### Reboot Mode

OPTION BITS	RST	P4.3	P2.7	P2.6	MODE
Bit4 L	H ↓	X	L	L	REBOOT
Bit5 L	H ↓	L	X	X	REBOOT

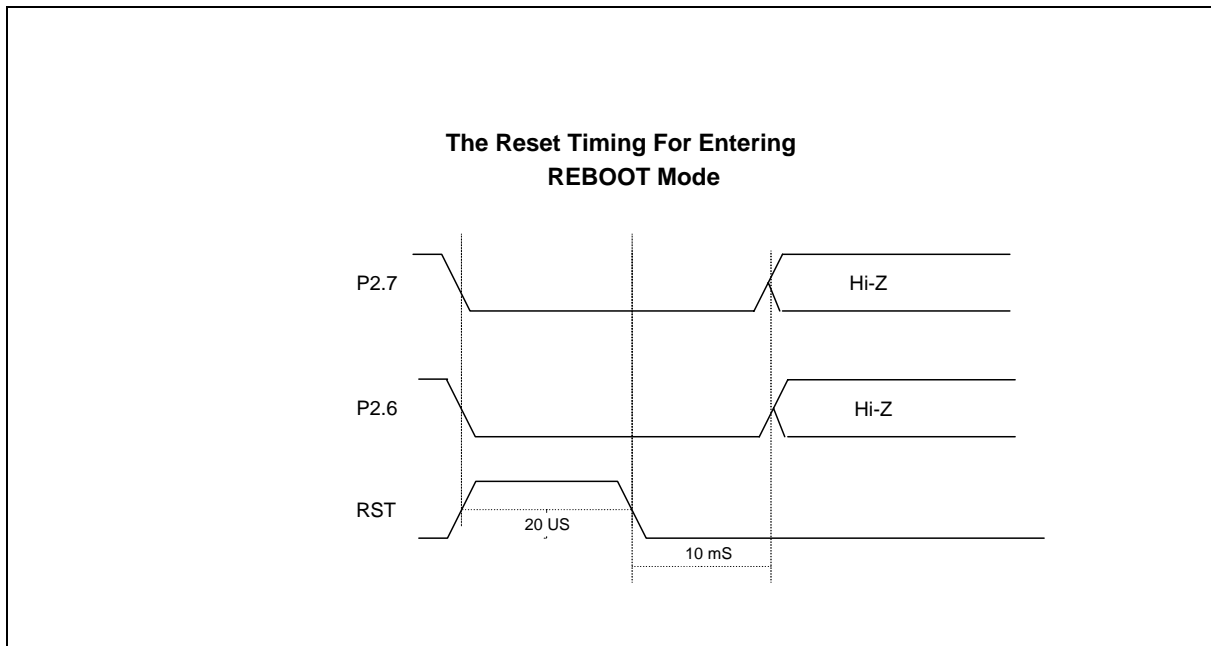

### Notes:

1. The possible situation that you need to enter REBOOT mode is when the APFlash program can not run normally and W79E648 can not jump to LDFlash to execute on chip programming function. Then you can use this REBOOT mode to force the CPU jump to LDFlash and run on chip programming procedure. When you design your system, you can connect the pins P26, P27 to switches or jumpers. For example in a CD ROM system, you can connect the P26 and P27 to PLAY and EJECT buttons on the panel. When the APFlash program is fail to execute the normal application program. User can press both two buttons at the same time and then switch on the power of the personal computer to force the W79E648 to enter the REBOOT mode. After power on of personal computer, you can release both PLAY and EJECT button. And re-run the on chip programming procedure to let the APFlash have the normal program code. Then you can back to normal condition of CD ROM.
2. In application system design, user must take care the P4.3, P2, P3, ALE, /EA and /PSEN pin value at reset to avoid W79E648 entering the programming mode or REBOOT mode in normal operation.



## 14. IN-SYSTEM PROGRAMMING

### 14.1 The Loader Program Locates at LDFlash Memory

CPU is Free Run at APFlash memory. CHPCON register had been set #03H value before CPU has entered idle state. CPU will switch to LDFlash memory and execute a reset action. H/W reboot mode will switch to LDFlash memory, too. Set SFRCN register where it locates at user's loader program to update APFlash bank 0 or bank 1 memory. Set a SWRESET ( CHPCON=#83H) to switch back APFlash after CPU has updated APFlash program. CPU will restart to run program from reset state.

### 14.2 The Loader Program Locates at APFlash Memory

CPU is Free Run at APFlash memory. CHPCON register had been set #01H value before CPU has entered idle state. Set SFRCN register to update LDFlash or another bank of APFlash program. CPU will continue to run user's APFlash program after CPU has updated program. Please refer demonstrative code to understand other detail description.

## 15. H/W WRITER MODE

This mode is for the writer to write / read Flash EPROM operation. A general user may not enter this mode.

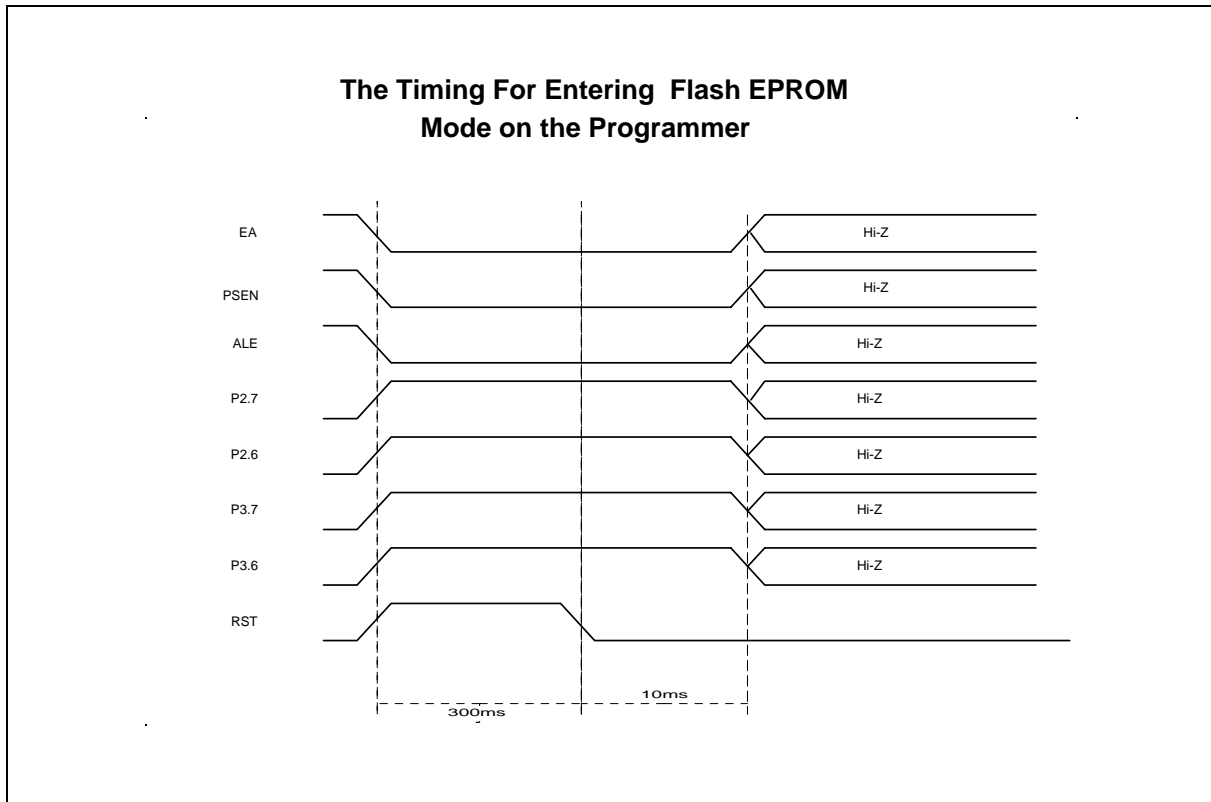



## 16. SECURITY BITS

1. Using device programmer, the Flash EPROM can be programmed and verified repeatedly. Until the code inside the Flash EPROM is confirmed OK, the code can be protected. The protection of Flash EPROM and those operations on it are described below. The W79E648 has Special Setting Register which can be accessed by device programmer. The register can only be accessed from the Flash EPROM operation mode. Those bits of the Security Registers can not be changed once they have been programmed from high to low. They can only be reset through erase-all operation. If you needn't have ISP function, please don't fill "FF" code on LD memory. The writer always writes AP and LD flashes every time.

B7	B6	B5	B4	B3	B2	B1	B0	Security Bits
----	----	----	----	----	----	----	----	---------------

B7: 1: XT > 24M hz, 0: XT < 24M hz.  
B5: 0 -> Eable H/W reboot with P4.3  
B4: 0 -> Enable H/W reboot with P2.6, P2.7  
B1: 0 -> Movc Inhibited  
B0 : 0-> Data out lock  
Default 1 for each bit.

## Option Bits

### **B0: Lock bit**

This bit is used to protect the customer's program code in the W79E648. It may be set after the programmer finishes the programming and verifies sequence. Once this bit is set to logic 0, both the Flash EPROM data and Special Setting Registers can not be accessed again.

### **B1: MOV C Inhibit**

This bit is used to restrict the accessible region of the MOV C instruction. It can prevent the MOV C instruction in external program memory from reading the internal program code. When this bit is set to logic 0, a MOV C instruction in external program memory space will be able to access code only in the external memory, not in the internal memory. A MOV C instruction in internal program memory space will always be able to access the ROM data in both internal and external memory. If this bit is logic 1, there are no restrictions on the MOV C instruction.

### **B4: H/W Reboot with P2.6 and P2.7**

If this bit is set to logic 0, enable to reboot 4k LDFlash mode while RST =H, P2.6 = L and P2.7 = L state. CPU will start from LDFlash to update the user's program.

### **B5: H/W Reboot with P4.3**

If this bit is set to logic 0, enable to reboot 4k LDFlash mode while RST =H and P4.3 = L state. CPU will start from LDFlash to update the user's program

### **B7: Select clock frequency.**

## Preliminary W79E648



---

If clock frequency is over 24M hz, then set this bit is H. If clock frequency is less than 24M hz, then clear this bit.



## 17. ELECTRICAL CHARACTERISTICS

### 17.1 Absolute Maximum Ratings

SYMBOL	PARAMETER	CONDITION	RATING	UNIT
DC Power Supply	VDD - VSS	-0.3	+7.0	V
Input Voltage	VIN	VSS -0.3	VDD +0.3	V
Operating Temperature	TA	0	+70	°C
Storage Temperature	Tst	-55	+150	°C

Note: Exposure to conditions beyond those listed under Absolute Maximum Ratings may adversely affect the life and reliability of the device.



## 17.2 DC Characteristics

(V<sub>DD</sub> – V<sub>SS</sub> = 5V ±10%, T<sub>A</sub> = 25°C, F<sub>osc</sub> = 20 MHz, unless otherwise specified.)

PARAMETER	SYMBOL	SPECIFICATION			TEST CONDITIONS
		MIN.	MAX.	UNIT	
Operating Voltage	V <sub>DD</sub>	4.5	5.5	V	
Operating Current	I <sub>DD</sub>	-	30	mA	No load V <sub>DD</sub> = RST = 5.5V
Idle Current	I <sub>IDLE</sub>	-	14	mA	Idle mode V <sub>DD</sub> = 5.5V
Power Down Current	I <sub>PWDN</sub>	-	10	μA	Power-down mode V <sub>DD</sub> = 5.5V
Input Current P1, P2, P3, P4, P5, P6, P7	I <sub>IN1</sub>	-50	+10	μA	V <sub>DD</sub> = 5.5V V <sub>IN</sub> = 0V or V <sub>DD</sub>
Input Current RST <sup>[*1]</sup>	I <sub>IN2</sub>	0	+1000	μA	V <sub>DD</sub> = 5.5V 0 < V <sub>IN</sub> < V <sub>DD</sub>
Input Leakage Current P0, $\overline{EA}$	I <sub>LK</sub>	-10	+10	μA	V <sub>DD</sub> = 5.5V 0V < V <sub>IN</sub> < V <sub>DD</sub>
Logic 1 to 0 Transition Current P1, P2, P3, P4, P5, P6, P7	I <sub>TL</sub> <sup>[*4]</sup>	-500	-200	μA	V <sub>DD</sub> = 5.5V V <sub>IN</sub> = 2.0V
Input Low Voltage P0, P1, P2, P3, $\overline{EA}$	V <sub>IL1</sub>	0	0.8	V	V <sub>DD</sub> = 4.5V
Input Low Voltage RST <sup>[*1]</sup>	V <sub>IL2</sub>	0	0.8	V	V <sub>DD</sub> = 4.5V
Input Low Voltage XTAL1 <sup>[*3]</sup>	V <sub>IL3</sub>	0	0.8	V	V <sub>DD</sub> = 4.5V
Input High Voltage P0, P1, P2, P3, P4, P5, P6, P7, $\overline{EA}$	V <sub>IH1</sub>	2.4	V <sub>DD</sub> + 0.2	V	V <sub>DD</sub> = 5.5V
Input High Voltage RST	V <sub>IH2</sub>	3.5	V <sub>DD</sub> + 0.2	V	V <sub>DD</sub> = 5.5V
Input High Voltage XTAL1 <sup>[*3]</sup>	V <sub>IH3</sub>	3.5	V <sub>DD</sub> + 0.2	V	V <sub>DD</sub> = 5.5V

# Preliminary W79E648



DC Characteristics, continued

PARAMETER	SYMBOL	SPECIFICATION			TEST CONDITIONS
		MIN.	MAX.	UNIT	
Sink current P1, P3, P4, P5, P6, P7	Isk1	4	8	mA	VDD = 4.5V Vs = 0.45V
Sink current P0, P2, ALE, $\overline{\text{PSEN}}$	Isk2	10	14	mA	VDD = 4.5V VOL = 0.45V
Source current P1, P3, P4, P5, P6, P7	Isr1	-180	-360	uA	VDD = 4.5V VOL = 2.4V
Source current P0, P2, ALE, $\overline{\text{PSEN}}$	Isr2	-10	-14	mA	VDD = 4.5V VOL = 2.4V
Output Low Voltage P1, P3, P4, P5, P6, P7	VOL1	-	0.45	V	VDD = 4.5V IOL = +6 mA
Output Low Voltage P0, P2, ALE, $\overline{\text{PSEN}}$ [2]	VOL2	-	0.45	V	VDD = 4.5V IOL = +10 mA
Output High Voltage P1, P3, P4, P5, P6, P7	VOH1	2.4	-	V	VDD = 4.5V IOH = -180 $\mu$ A
Output High Voltage P0, P2, ALE, $\overline{\text{PSEN}}$ [2]	VOH2	2.4	-	V	VDD = 4.5V IOH = -10mA

Notes:

- \*1. RST pin is a Schmitt trigger input.
- \*2. P0, ALE and  $\overline{\text{PSEN}}$  are tested in the external access mode.
- \*3. XTAL1 is a CMOS input.
- \*4. Pins of P1, P2, P3 can source a transition current when they are being externally driven from 1 to 0. The transition current reaches its maximum value when VIN approximates to 2V.

## 17.3 AC Characteristics

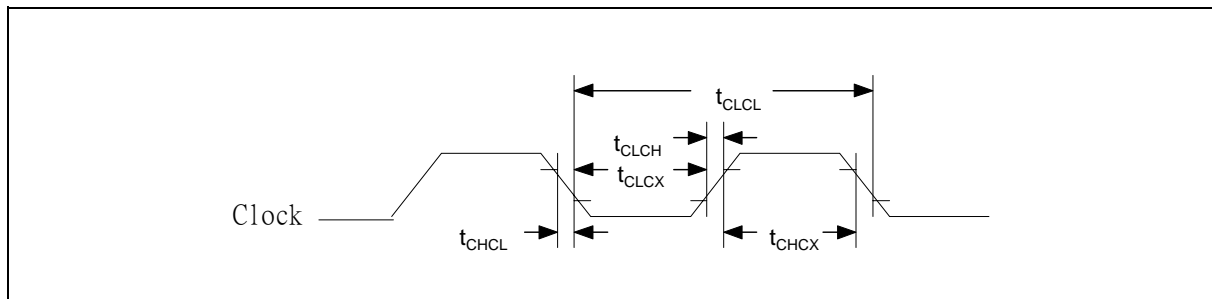

Note: Duty cycle is 50%.



## External Clock Characteristics

PARAMETER	SYMBOL	MIN.	TYP.	MAX.	UNITS	NOTES
Clock High Time	$t_{CHCX}$	12	-	-	nS	
Clock Low Time	$t_{CLCX}$	12	-	-	nS	
Clock Rise Time	$t_{CLCH}$	-	-	10	nS	
Clock Fall Time	$t_{CHCL}$	-	-	10	nS	

### 17.3.1 AC Specification

PARAMETER	SYMBOL	VARIABLE CLOCK MIN.	VARIABLE CLOCK MAX.	UNITS
Oscillator Frequency	$1/t_{CLCL}$	0	40	MHz
ALE Pulse Width	$t_{LHLL}$	$1.5t_{CLCL} - 5$		nS
Address Valid to ALE Low	$t_{AVLL}$	$0.5t_{CLCL} - 5$		nS
Address Hold After ALE Low	$t_{LLAX1}$	$0.5t_{CLCL} - 5$		nS
Address Hold After ALE Low for MOVX Write	$t_{LLAX2}$	$0.5t_{CLCL} - 5$		nS
ALE Low to Valid Instruction In	$t_{LLIV}$		$2.5t_{CLCL} - 20$	nS
ALE Low to PSEN Low	$t_{LLPL}$	$0.5t_{CLCL} - 5$		nS
$\overline{PSEN}$ Pulse Width	$t_{PLPH}$	$2.0t_{CLCL} - 5$		nS
$\overline{PSEN}$ Low to Valid Instruction In	$t_{PLIV}$		$2.0t_{CLCL} - 20$	nS
Input Instruction Hold After PSEN	$t_{PXIX}$	0		nS
Input Instruction Float After PSEN	$t_{PXIZ}$		$t_{CLCL} - 5$	nS
Port 0 Address to Valid Instr. In	$t_{AVIV1}$		$3.0t_{CLCL} - 20$	nS
Port 2 Address to Valid Instr. In	$t_{AVIV2}$		$3.5t_{CLCL} - 20$	nS
$\overline{PSEN}$ Low to Address Float	$t_{PLAZ}$	0		nS
Data Hold After Read	$t_{RHDX}$	0		nS
Data Float After Read	$t_{RHDZ}$		$t_{CLCL} - 5$	nS
$\overline{RD}$ Low to Address Float	$t_{RLAZ}$		$0.5t_{CLCL} - 5$	nS



## 17.3.2 MOVX Characteristics Using Stretch Memory Cycle

PARAMETER	SYMBOL	VARIABLE CLOCK MIN.	VARIABLE CLOCK MAX.	UNITS	STRECH
Data Access ALE Pulse Width	$t_{LLHL2}$	$1.5t_{CLCL} - 5$ $2.0t_{CLCL} - 5$		nS	$t_{MCS} = 0$ $t_{MCS} > 0$
Address Hold After ALE Low for MOVX write	$t_{LLAX2}$	$0.5t_{CLCL} - 5$		nS	
$\overline{RD}$ Pulse Width	$t_{RLRH}$	$2.0t_{CLCL} - 5$ $t_{MCS} - 10$		nS	$t_{MCS} = 0$ $t_{MCS} > 0$
$\overline{WR}$ Pulse Width	$t_{WLWH}$	$2.0t_{CLCL} - 5$ $t_{MCS} - 10$		nS	$t_{MCS} = 0$ $t_{MCS} > 0$
$\overline{RD}$ Low to Valid Data In	$t_{RLDV}$		$2.0t_{CLCL} - 20$ $t_{MCS} - 20$	nS	$t_{MCS} = 0$ $t_{MCS} > 0$
Data Hold after Read	$t_{RHDX}$	0		nS	
Data Float after Read	$t_{RHDZ}$		$t_{CLCL} - 5$ $2.0t_{CLCL} - 5$	nS	$t_{MCS} = 0$ $t_{MCS} > 0$
ALE Low to Valid Data In	$t_{LLDV}$		$2.5t_{CLCL} - 5$ $t_{MCS} + 2t_{CLCL} - 40$	nS	$t_{MCS} = 0$ $t_{MCS} > 0$
Port 0 Address to Valid Data In	$t_{AVDV1}$		$3.0t_{CLCL} - 20$ $2.0t_{CLCL} - 5$	nS	$t_{MCS} = 0$ $t_{MCS} > 0$
ALE Low to $\overline{RD}$ or $\overline{WR}$ Low	$t_{LLWL}$	$0.5t_{CLCL} - 5$ $1.5t_{CLCL} - 5$	$0.5t_{CLCL} + 5$ $1.5t_{CLCL} + 5$	nS	$t_{MCS} = 0$ $t_{MCS} > 0$
Port 0 Address to $\overline{RD}$ or $\overline{WR}$ Low	$t_{AVWL}$	$t_{CLCL} - 5$ $2.0t_{CLCL} - 5$		nS	$t_{MCS} = 0$ $t_{MCS} > 0$
Port 2 Address to $\overline{RD}$ or $\overline{WR}$ Low	$t_{AVWL2}$	$1.5t_{CLCL} - 5$ $2.5t_{CLCL} - 5$		nS	$t_{MCS} = 0$ $t_{MCS} > 0$
Data Valid to WR Transition	$t_{QVWX}$	-5 $1.0t_{CLCL} - 5$		nS	$t_{MCS} = 0$ $t_{MCS} > 0$
Data Hold after Write	$t_{WHQX}$	$t_{CLCL} - 5$ $2.0t_{CLCL} - 5$		nS	$t_{MCS} = 0$ $t_{MCS} > 0$
$\overline{RD}$ Low to Address Float	$t_{RLAZ}$		$0.5t_{CLCL} - 5$	nS	
$\overline{RD}$ or WR high to ALE high	$t_{WHLH}$	0 $1.0t_{CLCL} - 5$	10 $1.0t_{CLCL} + 5$	nS	$t_{MCS} = 0$ $t_{MCS} > 0$

Note:  $t_{MCS}$  is a time period related to the Stretch memory cycle selection. The following table shows the time period of  $t_{MCS}$  for each selection of the Stretch value.

M2	M1	M0	MOVX Cycles	$t_{MCS}$
0	0	0	2 machine cycles	0
0	0	1	3 machine cycles	$4 t_{CLCL}$
0	1	0	4 machine cycles	$8 t_{CLCL}$
0	1	1	5 machine cycles	$12 t_{CLCL}$
1	0	0	6 machine cycles	$16 t_{CLCL}$
1	0	1	7 machine cycles	$20 t_{CLCL}$
1	1	0	8 machine cycles	$24 t_{CLCL}$
1	1	1	9 machine cycles	$28 t_{CLCL}$

### Explanation of Logics Symbols

In order to maintain compatibility with the original 8051 family, this device specifies the same parameter for each device, using the same symbols. The explanation of the symbols is as follows.

t	Time	A	Address
C	Clock	D	Input Data
H	Logic level high	L	Logic level low
I	Instruction	P	$\overline{PSEN}$
Q	Output Data	R	$\overline{RD}$ signal
V	Valid	W	$\overline{WR}$ signal
X	No longer a valid state	Z	Tri-state

### 17.3.3 Program Memory Read Cycle

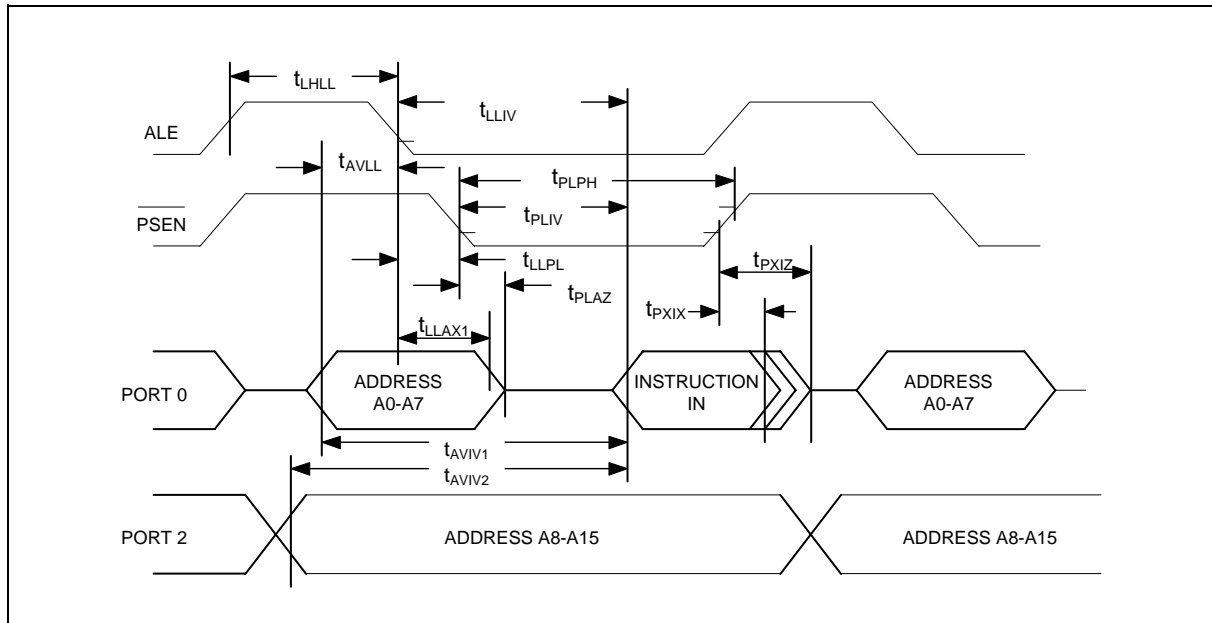



## 17.3.4 Data Memory Read Cycle

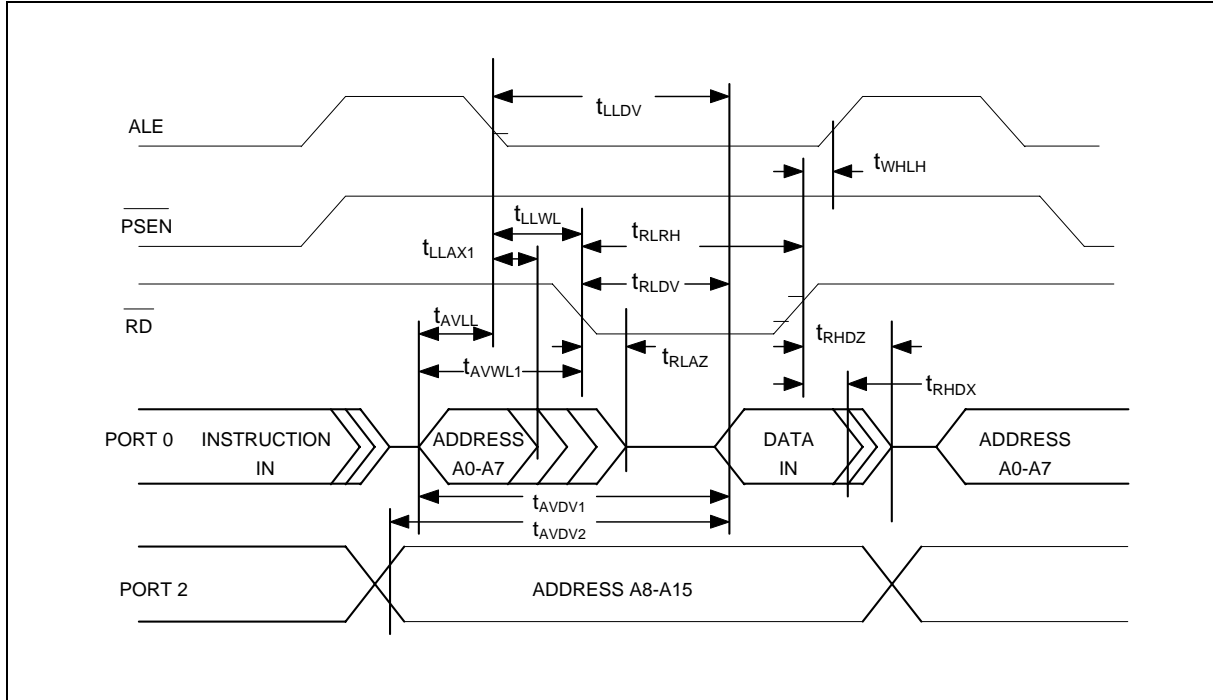

## 17.3.5 Data Memory Write Cycle

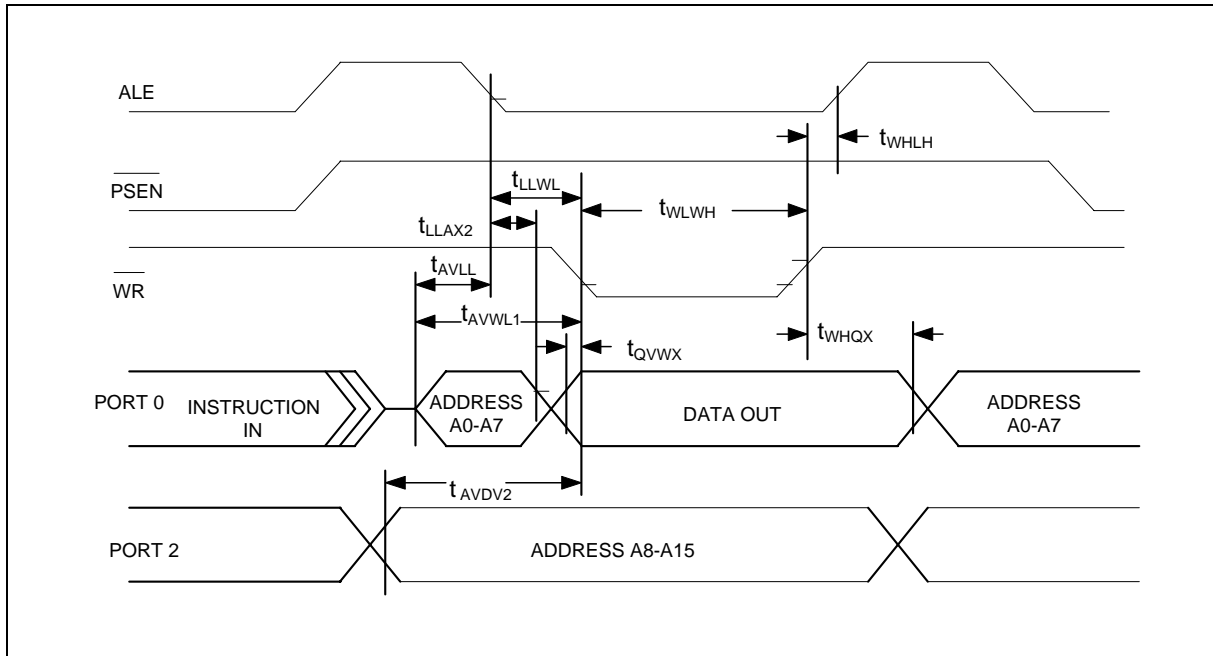





Typical Application Circuits, continued

## Expanded External Data Memory and Oscillator

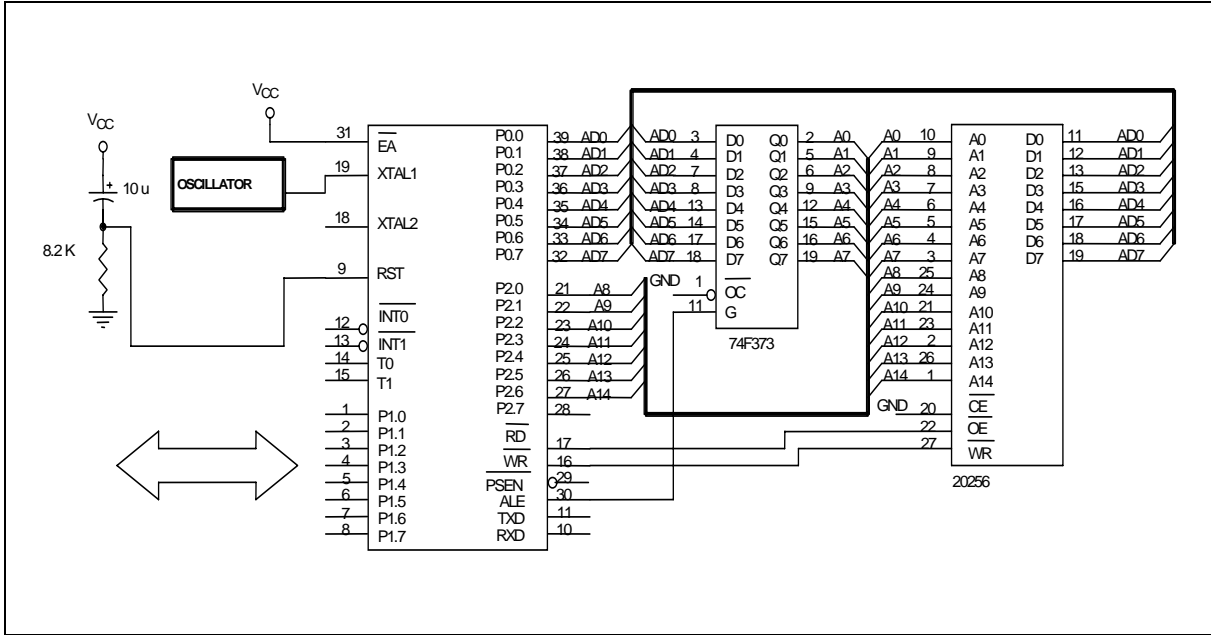
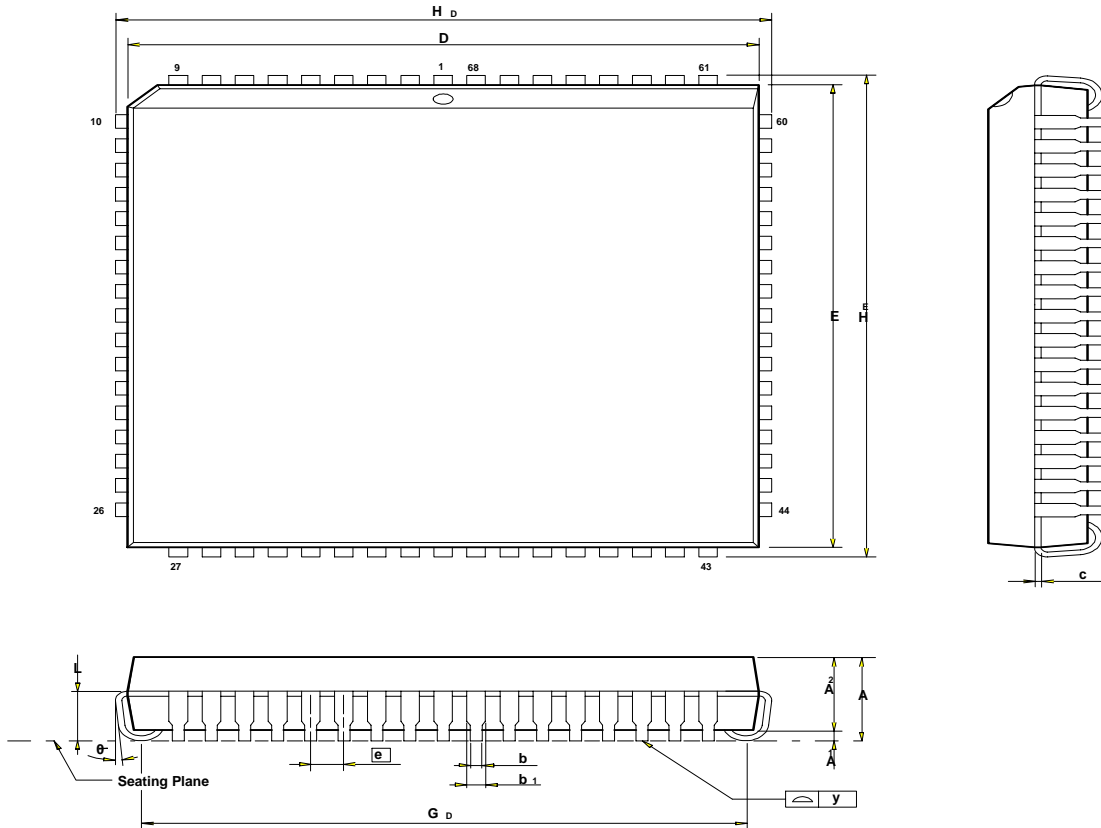

Figure B

## 19. PACKAGE DIMENSIONS

## 68 pin PLCC



Symbol	Dimension in inch			Dimension in mm		
	Min	Nom	Max	Min	Nom	Max
<b>A</b>	—	—	0.185	—	—	4.70
<b>A<sub>1</sub></b>	0.020	—	—	0.51	—	—
<b>A<sub>2</sub></b>	0.143	0.148	0.153	3.63	3.76	3.89
<b>b<sub>1</sub></b>	0.026	0.028	0.032	0.66	0.71	0.81
<b>b</b>	0.016	0.018	0.022	0.41	0.46	0.56
<b>c</b>	0.006	0.008	0.012	0.15	0.20	0.30
<b>D</b>	0.949	0.954	0.959	24.10	24.23	24.36
<b>E</b>	0.949	0.954	0.959	24.10	24.23	24.36
<b>e</b>	0.044	0.050	0.056	1.12	1.27	1.42
<b>G<sub>D</sub></b>	0.895	0.915	0.935	22.73	23.24	23.75
<b>G<sub>E</sub></b>	0.895	0.915	0.935	22.73	23.24	23.75
<b>H<sub>D</sub></b>	0.980	0.990	1.000	24.90	25.15	25.40
<b>H<sub>E</sub></b>	0.980	0.990	1.000	24.90	25.15	25.40
<b>L</b>	0.090	0.100	0.110	2.29	2.54	2.79
<b>y</b>	—	—	0.004	—	—	0.10
<b>θ</b>	0	—	10	0	—	10



## 20. APPLICATION NOTE

### In-system Programming Software Examples

This application note illustrates the in-system programmability of the Winbond W79E648 Flash EPROM microcontroller. In this example, microcontroller will boot from 64 KB APFlash bank and waiting for a key to enter in-system programming mode for re-programming the contents of 64 KB APFlash. While entering in-system programming mode, microcontroller executes the loader program in 4KB LDFlash bank. The loader program erases the 64 KB APFlash then reads the new code data from external SRAM buffer (or through other interfaces) to update the 64KB APFlash.

If the customer uses the reboot mode to update his program, please enable this b3 or b4 of security bits from the writer. Please refer security bits for detail description

#### EXAMPLE 1:

```

;*****
;
;* Example of 64K APFlash program: Program will scan the P1.0. if P1.0 = 0, enters in-system
;* programming mode for updating the content of APFlash code else executes the current ROM code.
;* XTAL = 24 MHz
;*****
;
    .chip 8052
    .RAMCHK OFF
    .symbols

CHPCON    EQU        9FH
TA        EQU        C7H
SFRAL     EQU        ACH
SFRAH     EQU        ADH
SFRFD     EQU        AEH
SFRCN     EQU        AFH

    ORG    0H
    LJMP  100H          ; JUMP TO MAIN PROGRAM
;*****
;* TIMER0 SERVICE VECTOR ORG = 000BH
;*****
;
    ORG 00BH
    CLR TR0            ; TR0 = 0, STOP TIMER0
    MOV TL0,R6
    MOV TH0,R7
    RETI
;*****
;* 64K APFlash MAIN PROGRAM
;*****
;
    ORG    100H

MAIN_64K:
    MOV A,P1          ; SCAN P1.0
    ANL A,#01H
    CJNE A,#01H,PROGRAM_64K ; IF P1.0 = 0, ENTER IN-SYSTEM PROGRAMMING MODE
    JMP NORMAL_MODE

```



```

PROGRAM_64:
    MOV TA, #AAH          ; CHPCON register is written protect by TA register.
    MOV TA, #55H
    MOV CHPCON, #03H     ; CHPCON = 03H, ENTER IN-SYSTEM PROGRAMMING MODE
    MOV SFRCN, #0H
    MOV TCON, #00H       ; TR = 0 TIMER0 STOP
    MOV IP, #00H         ; IP = 00H
    MOV IE, #82H         ; TIMER0 INTERRUPT ENABLE FOR WAKE-UP FROM IDLE MODE
    MOV R6, #F0H         ; TL0 = F0H
    MOV R7, #FFH         ; TH0 = FFH
    MOV TL0, R6
    MOV TH0, R7
    MOV TMOD, #01H       ; TMOD = 01H, SET TIMER0 A 16-BIT TIMER
    MOV TCON, #10H       ; TCON = 10H, TR0 = 1,GO
    MOV PCON, #01H      ; ENTER IDLE MODE FOR LAUNCHING THE IN-SYSTEM PROGRAMMING

```

```

;*****
;
;* Normal mode 64KB APFlash program: depending user's application
;*****
;

```

**NORMAL\_MODE:**

```

;
; User's application program
;
;
;

```

**EXAMPLE 2:**

```

;*****
;
Example of 4KB LDFlash program: This loader program will erase the 64KB APFlash first, then reads the new ;*
code from external SRAM and program them into 64KB APFlash bank. XTAL = 24 MHz
;*****
;

```

```

.chip 8052
.RAMCHK OFF
.symbols

```

```

CHPCON    EQU        9FH
TA        EQU        C7H
SFRAL     EQU        ACH
SFRAH     EQU        ADH
SFRFD     EQU        AEH
SFRCN     EQU        AFH

```

```

    ORG 000H
    LJMP 100H          ; JUMP TO MAIN PROGRAM

```

```

;*****
;
;* 1. TIMER0 SERVICE VECTOR ORG = 0BH
;*****
;

```

```

    ORG 000BH
    CLR TR0           ; TR0 = 0, STOP TIMER0
    MOV TL0, R6
    MOV TH0, R7

```

# Preliminary W79E648



## RETI

```
.*****
;
;* 4KB LDFlash MAIN PROGRAM
.*****
;
      ORG 100H
MAIN_4K:
      MOV TA,#AAH
      MOV TA,#55H
      MOV CHPCON,#03H      ; CHPCON = 03H, ENABLE IN-SYSTEM PROGRAMMING.
      MOV SFRCN,#0H
      MOV TCON,#00H      ; TCON = 00H, TR = 0 TIMER0 STOP
      MOV TMOD,#01H      ; TMOD = 01H, SET TIMER0 A 16BIT TIMER
      MOV IP,#00H        ; IP = 00H
      MOV IE,#82H        ; IE = 82H, TIMER0 INTERRUPT ENABLED
      MOV R6,#F0H
      MOV R7,#FFH
      MOV TL0,R6
      MOV TH0,R7
      MOV TCON,#10H      ; TCON = 10H, TR0 = 1, GO
      MOV PCON,#01H      ; ENTER IDLE MODE

UPDATE_64K:
      MOV TCON,#00H      ; TCON = 00H , TR = 0 TIM0 STOP
      MOV IP,#00H        ; IP = 00H
      MOV IE,#82H        ; IE = 82H, TIMER0 INTERRUPT ENABLED
      MOV TMOD,#01H      ; TMOD = 01H, MODE1
      MOV R6,#D0H        ; SET WAKE-UP TIME FOR ERASE OPERATION, ABOUT 15 ms
                          ; DEPENDING ON USER'S SYSTEM CLOCK RATE.

      MOV R7,#8AH
      MOV TL0,R6
      MOV TH0,R7

ERASE_P_4K:
      MOV SFRCN,#22H      ; SFRCN = 22H, ERASE 64K APFlash0
                          ; SFRCN = A2H, ERASE 64K APFlash1
      MOV TCON,#10H      ; TCON = 10H, TR0 = 1,GO
      MOV PCON,#01H      ; ENTER IDLE MODE (FOR ERASE OPERATION)

.*****
;
;* BLANK CHECK
.*****
;
      MOV SFRCN,#0H      ; SFRCN = 00H, READ 64KB APFlash0
                          ; SFRCN = 80H, READ 64KB APFlash1
      MOV SFRAH,#0H      ; START ADDRESS = 0H
      MOV SFRAL,#0H
      MOV R6,#FDH        ; SET TIMER FOR READ OPERATION, ABOUT 1.5 μS.
      MOV R7,#FFH
      MOV TL0,R6
      MOV TH0,R7

BLANK_CHECK_LOOP:
      SETB TR0           ; ENABLE TIMER 0
      MOV PCON,#01H      ; ENTER IDLE MODE
      MOV A,SFRFD        ; READ ONE BYTE
```

# Preliminary W79E648



```
CJNE A,#FFH,BLANK_CHECK_ERROR
INC SFRAL          ; NEXT ADDRESS
MOV A,SFRAL
JNZ BLANK_CHECK_LOOP
INC SFRAH
MOV A,SFRAH
CJNE A,#0H,BLANK_CHECK_LOOP ; END ADDRESS = FFFFH
JMP PROGRAM_64KROM
```

BLANK\_CHECK\_ERROR:

```
JMP $
```

```
*****
;
;* RE-PROGRAMMING 64KB APFlash BANK
*****
```

PROGRAM\_64KROM:

```
MOV R2,#00H          ; TARGET LOW BYTE ADDRESS
MOV R1,#00H          ; TARGET HIGH BYTE ADDRESS
MOV DPTR,#0H
MOV SFRAH,R1         ; SFRAH, TARGET HIGH ADDRESS
MOV SFRCN,#21H       ; SFRCN = 21H, PROGRAM 64K APFLASH0
                       ; SFRCN = A1H, PROGRAM 64K APFLASH1
MOV R6,#9CH          ; SET TIMER FOR PROGRAMMING, ABOUT 50 μS.
MOV R7,#FFH
MOV TL0,R6
MOV TH0,R7
```

PROG\_D\_64K:

```
MOV SFRAL,R2         ; SFRAL = LOW BYTE ADDRESS
CALL GET_BYTE_FROM_PC_TO_ACC ; THIS PROGRAM IS BASED ON USER'S CIRCUIT.
MOV @DPTR,A          ; SAVE DATA INTO SRAM TO VERIFY CODE.
MOV SFRFD,A          ; SFRFD = DATA IN
MOV TCON,#10H        ; TCON = 10H, TR0 = 1,GO
MOV PCON,#01H        ; ENTER IDLE MODE (PROGRAMMING)
INC DPTR
INC R2
CJNE R2,#0H,PROG_D_64K
INC R1
MOV SFRAH,R1
CJNE R1,#0H,PROG_D_64K
```

```
*****
;
;* VERIFY 64KB APFLASH BANK
*****
```

```
MOV R4,#03H          ; ERROR COUNTER
MOV R6,#FDH          ; SET TIMER FOR READ VERIFY, ABOUT 1.5 μS.
MOV R7,#FFH
MOV TL0,R6
MOV TH0,R7
MOV DPTR,#0H         ; The start address of sample code
MOV R2,#0H           ; Target low byte address
MOV R1,#0H           ; Target high byte address
MOV SFRAH,R1         ; SFRAH, Target high address
MOV SFRCN,#00H       ; SFRCN = 00H, Read APFlash0
```

# Preliminary W79E648



```
                                ; SFRCN = 80H , Read APFlash1

READ_VERIFY_64K:
    MOV SFRAL,R2                ; SFRAL = LOW ADDRESS
    MOV TCON,#10H              ; TCON = 10H, TR0 = 1,GO
    MOV PCON,#01H
    INC R2
    MOVX A,@DPTR
    INC DPTR
    CJNE A,SFRFD,ERROR_64K
    CJNE R2,#0H,READ_VERIFY_64K
    INC R1
    MOV SFRAH,R1
    CJNE R1,#0H,READ_VERIFY_64K

;*****
;
;* PROGRAMMING COMPLETELY, SOFTWARE RESET CPU
;*****
;
    MOV TA,#AAH
    MOV TA,#55H
    MOV CHPCON,#83H           ; SOFTWARE RESET. CPU will restart from APFlash0

ERROR_64K:
    DJNZ R4,UPDATE_64K       ; IF ERROR OCCURS, REPEAT 3 TIMES.
                                ; IN-SYST PROGRAMMING FAIL, USER'S PROCESS TO DEAL WITH IT.
    .
    .
    .
```

# Preliminary W79E648



## 21. REVISION HISTORY

VERSION	DATE	PAGE	DESCRIPTION
A1	July 8, 2003	-	Initial Issued



### Headquarters

No. 4, Creation Rd. III,  
Science-Based Industrial Park,  
Hsinchu, Taiwan  
TEL: 886-3-5770066  
FAX: 886-3-5665577  
<http://www.winbond.com.tw/>

### Taipei Office

9F, No.480, Rueiguang Rd.,  
Neihu District, Taipei, 114,  
Taiwan, R.O.C.  
TEL: 886-2-8177-7168  
FAX: 886-2-8751-3579

### Winbond Electronics Corporation America

2727 North First Street, San Jose,  
CA 95134, U.S.A.  
TEL: 1-408-9436666  
FAX: 1-408-5441798

### Winbond Electronics Corporation Japan

7F Daini-ueno BLDG, 3-7-18  
Shinyokohama Kohoku-ku,  
Yokohama, 222-0033  
TEL: 81-45-4781881  
FAX: 81-45-4781800

### Winbond Electronics (Shanghai) Ltd.

27F, 2299 Yan An W. Rd. Shanghai,  
200336 China  
TEL: 86-21-62365999  
FAX: 86-21-62365998

### Winbond Electronics (H.K.) Ltd.

Unit 9-15, 22F, Millennium City,  
No. 378 Kwun Tong Rd.,  
Kowloon, Hong Kong  
TEL: 852-27513100  
FAX: 852-27552064

*Please note that all data and specifications are subject to change without notice.  
All the trade marks of products and companies mentioned in this data sheet belong to their respective owners.*