

Features

- Epitaxial Planar Die Construction
- Low Noise
- High Current Gain
- Matched Pair of Transistors

Mechanical Data

- Case: SOT-363, Molded Plastic
- Terminals: Solderable per MIL-STD-202, Method 208
- Terminal Connections: See Diagram
- Marking: K3S
- Weight: .006 grams (approx.)

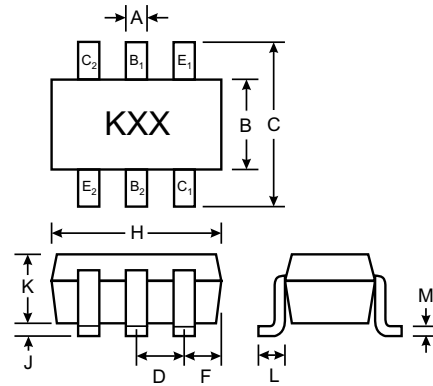

SOT-363		
Dim	Min	Max
A	0.10	0.30
B	1.15	1.35
C	2.00	2.20
D	0.65 Nominal	
F	0.30	0.40
H	1.80	2.20
J	—	0.10
K	0.90	1.00
L	0.25	0.40
M	0.10	0.25
All Dimensions in mm		

Maximum Ratings @ T_A = 25°C unless otherwise specified

Characteristic	Symbol	DMDT9922	Unit
Collector-Base Voltage	V _{CBO}	-50	V
Collector-Emitter Voltage	V _{CEO}	-40	V
Emitter-Base Voltage	V _{EBO}	-5.0	V
Collector-Collector Voltage	V _{CCO}	-50	V
Emitter-Emitter Voltage	V _{EEO}	-50	V
Collector Current - Continuous (Note 1)	I _C	-100	mA
Power Dissipation (Note 1)	P _d	200	mW
Thermal Resistance, Junction to Ambient (Note 1)	R _{θJA}	625	K/W
Operating and Storage and Temperature Range	T _j , T _{STG}	-55 to +125	°C

UNAPPROVED
NOT FOR
DISTRIBUTION

Electrical Characteristics @ $T_A = 25^\circ\text{C}$ unless otherwise specified

Characteristic	Symbol	Min	Typ	Max	Unit	Test Condition
OFF CHARACTERISTICS (Note 2)						
Collector-Base Breakdown Voltage	$V_{(BR)CBO}$	-50	—	—	V	$I_C = -50\mu\text{A}, I_E = 0$
Collector-Emitter Breakdown Voltage	$V_{(BR)CEO}$	-40	—	—	V	$I_C = -1.0\text{mA}, I_B = 0$
Emitter-Base Breakdown Voltage	$V_{(BR)EBO}$	-5.0	—	—	V	$I_E = -50\mu\text{A}, I_C = 0$
Collector-Base Leakage Current	I_{CBO}	—	-0.3	-500	nA	$V_{CB} = -30\text{V}$
Emitter-Base Leakage Current	I_{EBO}	—	—	-500	nA	$V_{EB} = -4.0\text{V}$
Collector-Emitter Leakage Current	I_{CES}	—	-4	-1000	nA	$V_{CE} = -40\text{V}$
ON CHARACTERISTICS (Note 2)						
DC Current Gain	h_{FE}	300	450	555	—	$I_C = -1.0\text{mA}, V_{CE} = -6.0\text{V}$
Collector-Emitter Saturation Voltage	$V_{CE(SAT)}$ $V_{CE(SAT)}$	—	-0.1 -0.1	-0.5 —	V V	$I_C = -50\text{mA}, I_B = -5.0\text{mA}$ $I_C = -1\text{mA}, I_B = -0.1\text{mA}$
Base-Emitter Impedance	r_{be}	—	-0.5	—	Ω	$I_C = -10\mu\text{A}$ to -1mA
Emitter-Base Offset Voltage	V_{OS}	—	10	—	μV	$V_{CB} = 0\text{V}, I_C = -1\mu\text{A}$ to -1mA
Change in Emitter-Base Offset Voltage vs. Collector-Base Voltage (CMRR)	$\frac{\Delta V_{OS}}{\Delta V_{CB}}$	—	10	—	μV	$V_{CB} = 0\text{V}, I_C = -1\mu\text{A}$ to -1mA
Change in Emitter-Base Offset Voltage vs. Collector-Current	$\frac{\Delta V_{OS}}{\Delta I_C}$	—	5	—	μV	$V_{CB} = 0\text{V}, I_C = -10\mu\text{A}$ to -1mA
Average Offset Voltage Drift	$TC V_{OS}$	—	0.5	—	$\mu\text{V}/^\circ\text{C}$	$I_C = -10\mu\text{A}$ to -1mA
Emitter-Base Offset Current	I_{OS}	—	8	—	nA	$I_C = -10\mu\text{A}, V_{CB} = 0\text{V}$
Change in Emitter-Base Offset Current vs. Collector-Base Voltage	$\frac{\Delta I_{OS}}{\Delta V_{CB}}$	—	30	—	nA	$V_{CB} = 0$ to -50V
Average Offset Current Drift	$TC I_{OS}$	—	50	—	$\text{pA}/^\circ\text{C}$	$I_C = -10\mu\text{A}$
Collector-Collector Leakage Current	I_{CC}	—	35	—	pA	$V_{CE} = -40\text{V}$
SMALL SIGNAL CHARACTERISTICS						
Output Capacitance	C_{obo}		-4	15	pF	$V_{CB} = -10\text{V}, f = 1.0\text{MHz}, I_E = 0$
Input Capacitance	C_{ibo}	—	—	70	pF	$V_{EB} = -0.5\text{V}, I_C = 0, f = 1\text{MHz}$
Output Conductance	h_{OE}	—	10	—	μS	$I_C = -1\text{mA}, V_{CE} = -5\text{V}$
Current Gain-Bandwidth Product	f_T		170	—	MHz	$V_{CE} = -12\text{V}, I_C = -2.0\text{mA}, f = 100\text{MHz}$

- Notes: 1. Valid provided that terminals are kept at ambient temperature.
2. Pulse test: Pulse width $\leq 300\mu\text{s}$, duty cycle $\leq 2\%$.

UNAPPROVED
NOT FOR
DISTRIBUTION