



## Features

- Superior voice solution with low noise and excellent part-to-part gain accuracy
- 3 kV<sub>RMS</sub> line isolation
- Simultaneous ringing detection and CID monitoring for worldwide applications
- Provides both full-wave ringing detect and half-wave ringing detect for maximum versatility
- Transmit power of up to +10 dBm into 600 Ω
- Data access arrangement (DAA) solution for modem speeds up to V.92
- 3.3V or 5 V power supply operation
- Easy interface with modem ICs and voice CODECs
- Worldwide dial-up telephone network compatibility
- CPC5622 can be used in circuits that comply with the requirements of TIA/EIA/IS-968 (FCC part 68), UL60950 (UL1950), EN60950, IEC60950, EN55022B, CISPR22B, EN55024, and TBR-21
- Line-side circuit powered from telephone line
- Compared to other silicon DAA solutions, LITELINK:
  - Uses fewer passive components
  - Takes up less printed-circuit board space
  - Uses less telephone line power
  - Is a single-IC solution

## Applications

- Computer telephony and gateways, such as VoIP
- PBXs
- Satellite and cable set-top boxes
- V.92 (and other standard) modems
- Fax machines
- Voicemail systems

- Embedded modems for POS terminals, automated banking, remote metering, vending machines, security, and surveillance

## Description

LITELINK III is a single-package silicon phone line interface (PLI) DAA used in voice and data communication applications to make connections between host equipment and telephone networks.

LITELINK uses on-chip optical components and a few inexpensive external components to form the required high voltage isolation barrier. LITELINK eliminates the need for large isolation transformers or capacitors used in other phone line interface configurations.

LITELINK also provides AC and DC phone line terminations, switchhook, 2-wire to 4-wire hybrid, ringing detection, and full time receive on-hook transmission capability.

The CPC5622 is a member of and builds upon Clare's third generation of LITELINK products with improved insertion loss performance and lower minimum current draw from the phone line. The CPC5622 version of LITELINK III provides concurrent ringing detection and CID monitoring for world wide applications. Both half-wave and full-wave ringing detection are provided for maximum versatility.

## Ordering Information

Part Number	Description
CPC5622A	32-pin Phone Line Interface, 50/tube
CPC5622ATR	32-pin Phone Line Interface, tape and reel, 1000/reel

**Figure 1. CPC5622 Block Diagram**

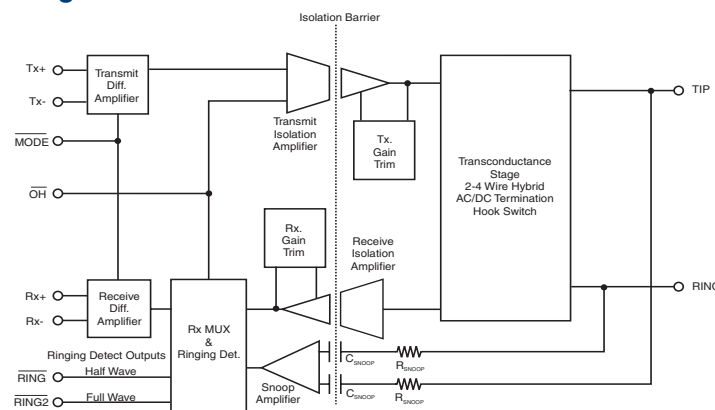



<b>1. Electrical Specifications</b> .....	<b>3</b>
1.1 Absolute Maximum Ratings .....	3
1.2 Performance .....	3
1.3 Pin Description .....	5
<b>2. Application Circuits</b> .....	<b>6</b>
2.1 Resistive Termination Application Circuit .....	6
2.1.1 Resistive Termination Application Circuit Part List .....	7
2.2 Reactive Termination Application Circuit .....	8
2.2.1 Reactive Termination Application Circuit Part List .....	9
<b>3. Using LITELINK</b> .....	<b>10</b>
3.1 Switch Hook Control (On-hook and Off-hook States) .....	10
3.2 On-hook Operation: $\overline{OH}=1$ .....	10
3.2.1 Ringing Signal Reception via the Snoop Circuit .....	10
3.3 Off-Hook Operation: $\overline{OH}=0$ .....	12
3.3.1 Receive Signal Path .....	12
3.3.2 Transmit Signal Path .....	12
3.4 Initialization Requirement Following Power-up .....	13
3.5 DC Characteristics .....	13
3.5.1 Setting a Current Limit .....	13
3.6 AC Characteristics .....	13
3.6.1 Resistive Termination Applications .....	13
3.6.2 Reactive Termination Applications .....	13
3.6.3 Mode Pin Usage .....	13
<b>4. Regulatory Information</b> .....	<b>14</b>
<b>5. LITELINK Design Resources</b> .....	<b>14</b>
5.1 Clare, Inc. Design Resources .....	14
<b>6. LITELINK Performance</b> .....	<b>15</b>
<b>7. Manufacturing Information</b> .....	<b>17</b>
7.1 Mechanical Dimensions .....	17
7.2 Tape and Reel Packaging .....	18
7.3 Manufacturing Assembly Processes .....	18
7.3.1 Moisture Reflow Sensitivity .....	18
7.3.2 Reflow Profile .....	18



# 1. Electrical Specifications

www.DataSheet4U.com

## 1.1 Absolute Maximum Ratings

Parameter	Minimum	Maximum	Unit
Isolation Voltage	-	3000	$V_{RMS}$
Continuous Tip to Ring Current ( $R_{ZDC} = 5.2\Omega$ )		150	mA
Total Package Power Dissipation		1	W
$V_{DD}$	-0.3	6	V
Logic Inputs	-0.3	$V_{DD} + 0.3$	V
Operating temperature	-40	+85	$^{\circ}C$
Storage temperature	-40	+125	$^{\circ}C$

Absolute maximum ratings are stress ratings. Stresses in excess of these ratings can cause permanent damage to the device. Functional operation of the device at conditions beyond those indicated in the operational sections of this data sheet is not implied.

Unless otherwise specified all specifications are at 25 $^{\circ}C$  and  $V_{DD}=5.0V$ .

## 1.2 Performance

Parameter	Minimum	Typical	Maximum	Unit	Conditions
<b>DC Characteristics</b>					
Operating Voltage $V_{DD}$	3.0	-	5.5	V	Host side
Operating Current $I_{DD}$	-	9	13	mA	Host side
Operating Voltage $V_{DDL}$	2.8	-	3.2	V	Line side, derived from tip and ring
Operating Current $I_{DDL}$	-	7	8	mA	Line side, drawn from tip and ring while off-hook
<b>On-hook Characteristics</b>					
Metallic DC Resistance	10	-	-	$M\Omega$	Tip to ring, 100 Vdc applied
Longitudinal DC Resistance	10	-	-	$M\Omega$	150 Vdc applied from tip and ring to Earth ground
Ring Signal Detect Level	5	-	-	$V_{RMS}$	68 Hz ringing signal applied to tip and ring
Ring Signal Detect Level	28	-	-	$V_{RMS}$	15 Hz ringing signal applied across tip and ring
Snoop Circuit Frequency Response	166	-	>4000	Hz	-3 dB corner frequency @ 166 Hz, in Clare application circuit
Snoop Circuit CMRR <sup>1</sup>	-	40	-	dB	120 $V_{RMS}$ 60 Hz common-mode signal across tip and ring
Ringer Equivalence	-	0.01B	-	REN	
Longitudinal Balance <sup>1</sup>	60	-	-	dB	Per FCC part 68
<b>Off-Hook Characteristics</b>					
AC Impedance	-	600	-	$\Omega$	Tip to ring, using resistive termination application circuit
Longitudinal Balance <sup>1</sup>	60	-	-	dB	Per FCC part 68
Return Loss	-	26	-	dB	Into 600 $\Omega$ at 1800 Hz
<b>Transmit and Receive Characteristics</b>					
Frequency Response	30	-	4000	Hz	-3 dB corner frequency 30 Hz

Parameter	Minimum	Typical	Maximum	Unit	Conditions
Transhybrid Loss	-	36	-	dB	Into 600 $\Omega$ at 1800 Hz, with C18 in the resistive termination application circuit
Transmit and Receive Insertion Loss	-0.4	0	0.4	dB	30 Hz to 4 kHz, Resistive termination application circuit with $\overline{\text{MODE}}$ de-asserted. Reactive termination application circuit with $\overline{\text{MODE}}$ asserted.
Average In-band Noise	-	-126	-	dBm/Hz	4 kHz flat bandwidth
Harmonic Distortion	-	-80	-	dB	-3 dBm, 600 Hz, 2 <sup>nd</sup> harmonic
Transmit Level	-	-	2.2	V <sub>P-P</sub>	Single-tone sine wave. Or 0 dBm into 600 $\Omega$ .
Receive Level	-	-	2.2	V <sub>P-P</sub>	Single-tone sine wave. Or 0 dBm into 600 $\Omega$ .
RX+/RX- Output Drive Current	-	-	0.5	mA	Sink and source
TX+/TX- Input Impedance	60	90	120	k $\Omega$	
<b>Isolation Characteristics</b>					
Isolation Voltage	3000	-	-	V <sub>rms</sub>	Line side to host side, one minute duration
Surge Rise Time	2000	-	-	V/ $\mu$ S	No damage via tip and ring
<b><math>\overline{\text{MODE}}</math> and <math>\overline{\text{OH}}</math> Control Logic Inputs</b>					
Input Low Voltage	-	-	0.8	V <sub>IL</sub>	
Input High Voltage	2.0	-	-	V <sub>IH</sub>	
High Level Input Current	-	-	-120	$\mu$ A	V <sub>IN</sub> $\leq$ V <sub>DD</sub>
Low Level Input Current	-	-	-120	$\mu$ A	V <sub>IN</sub> = GND
<b><math>\overline{\text{RING}}</math> and <math>\overline{\text{RING2}}</math> Output Logic Levels</b>					
Output High Voltage	V <sub>DD</sub> -0.4	-	-	V	I <sub>OUT</sub> = -400 $\mu$ A
Output Low Voltage	-	-	0.4	V	I <sub>OUT</sub> = 1 mA
<i>Specifications subject to change without notice. All performance characteristics based on the use of Clare application circuits. Functional operation of the device at conditions beyond those specified here is not implied.</i>					

## NOTES:

1) This parameter is layout and component tolerance dependent.

### 1.3 Pin Description

Pin	Name	Function
1	V <sub>DD</sub>	Host (CPE) side power supply
2	TXSM	Transmit summing junction
3	TX-	Negative differential transmit signal to DAA from host
4	TX+	Positive differential transmit signal to DAA from host
5	TX	Transmit differential amplifier output
6	MODE	When asserted low, changes gain of TX path (-7 dB) and RX path (+7 dB) to accommodate reactive termination networks
7	GND	Host (CPE) side analog ground
8	OH	Assert logic low for off-hook operation
9	RING	Half wave ringing detect output signal
10	RING2	Full wave ringing detect output signal
11	RX-	Negative differential analog signal received from the telephone line. Must be AC coupled with 0.1 μF.
12	RX+	Positive differential analog signal received from the telephone line. Must be AC coupled with 0.1 μF.
13	SNP+	Positive differential snoop input
14	SNP-	Negative differential snoop input
15	RXF	Receive photodiode amplifier output
16	RX	Receive photodiode summing junction
17	V <sub>DDL</sub>	Power supply for line side, regulated from tip and ring.
18	RXS	Receive isolation amp summing junction
19	RPB	Receive LED pre-bias current set
20	BR-	Bridge rectifier return
21	ZDC	Electronic inductor DCR/current limit
22	DCS2	DC feedback output
23	DCS1	V to I slope control
24	NTF	Network amplifier feedback
25	GAT	External MOSFET gate control
26	NTS	Receive signal input
27	BR-	Bridge rectifier return
28	TXSL	Transmit photodiode summing junction
29	ZNT	Receiver impedance set
30	ZTX	Transmit transconductance gain set
31	TXF	Transmit photodiode amplifier output
32	REFL	1.25 Vdc reference

Figure 2. Pinout

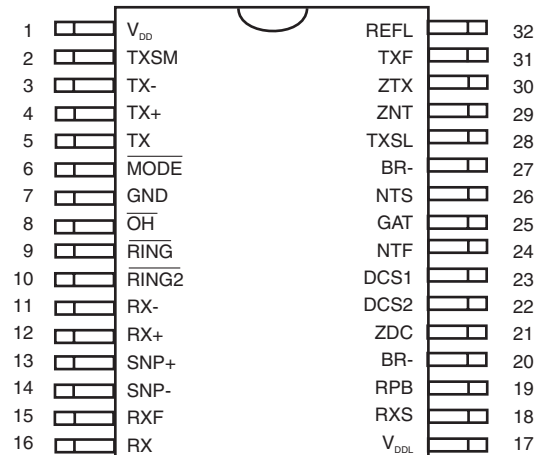

## 2. Application Circuits

www.DataSheet4U.com

LITELINK can be used with telephone networks worldwide. Some public telephone networks, notably in North America and Japan require a resistive line termination. Other telephone networks as in Europe, China and elsewhere require reactive line termination.

The application circuits that follow address both types of line termination models. A reactive termination application circuit that describes a TBR-21 implementation is shown in **Figure 2.2 on page 8**. This circuit can be easily adapted for other reactive termination needs.

### 2.1 Resistive Termination Application Circuit

**Figure 3. Resistive Termination Application Circuit Schematic**

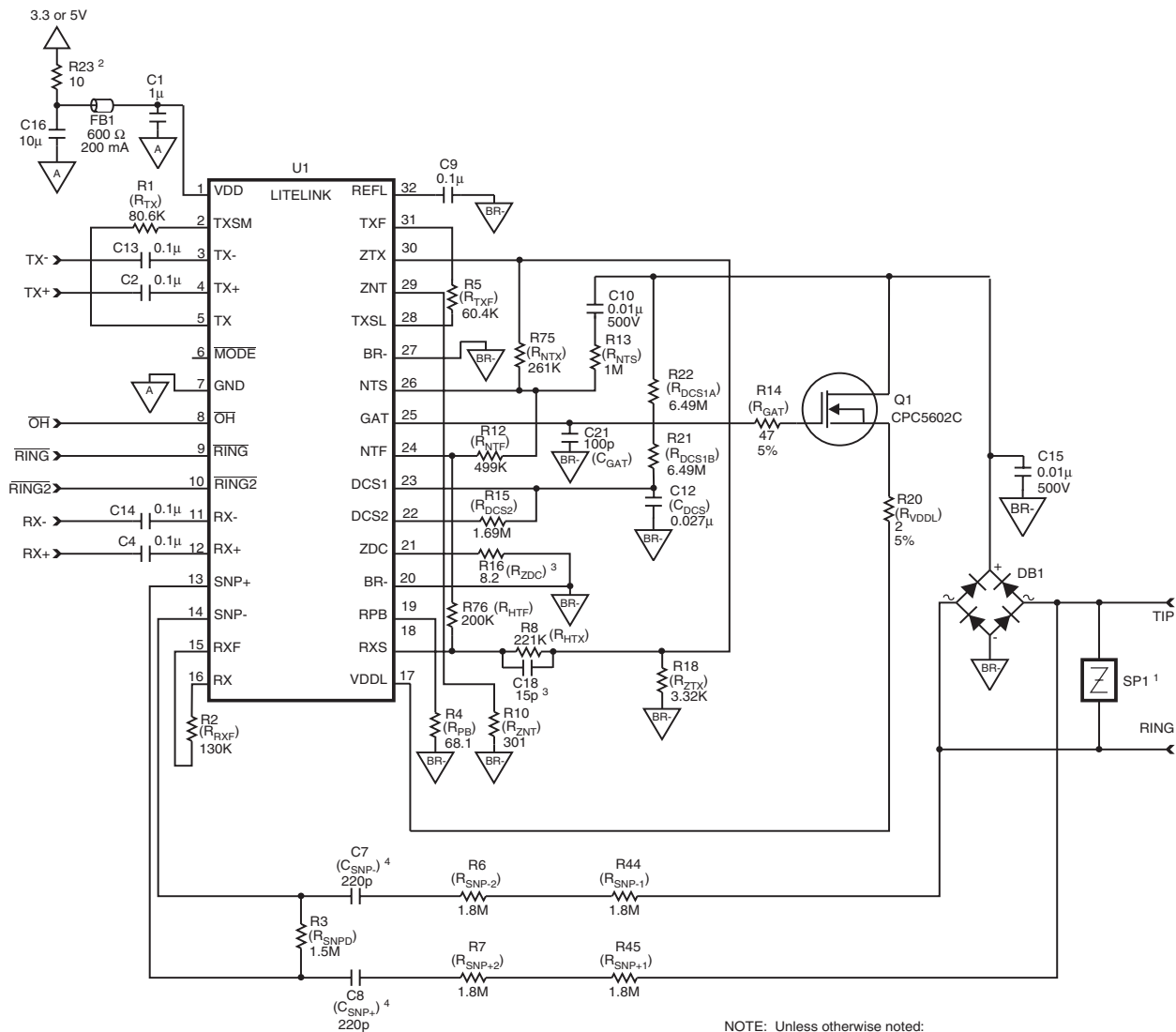

<sup>1</sup>This design was tested and found to comply with FCC Part 68 with this Sidactor. Other compliance requirements may require a different part.  
<sup>2</sup>Higher-noise power supplies may require substitution of a 220 µH inductor, Toko 380HB-2215 or similar. See the Power Quality section of Clare application note AN-146, [Guidelines for Effective LITELINK Designs](#) for more information.  
<sup>3</sup>Optional for enhanced transhybrid loss.

<sup>4</sup>Use voltage ratings based on the isolation requirements of your application.



## 2.1.1 Resistive Termination Application Circuit Part List

Quantity	Reference Designator	Description	Supplier(s)
1	C1	1 $\mu$ F, 16 V, $\pm$ 10%	AVX, Murata, Novacap, Panasonic, SMEC, Tecate, etc.
5	C2, C4, C9, C13, C14	0.1 $\mu$ F, 16 V, $\pm$ 10%	
2	C7, C8 <sup>1</sup>	220 pF, $\pm$ 5%	
2	C10, C15	0.01 $\mu$ F, 500 V, $\pm$ 10%	
1	C12	0.027 $\mu$ F, 16 V, $\pm$ 10%	
1	C16	10 $\mu$ F, 16 V, $\pm$ 10%	
1	C18 (optional)	15 pF, 16 V, $\pm$ 10%	
1	C21	100 pF, 16 V, 10%	
1	R1	80.6 k $\Omega$ , 1/16 W, $\pm$ 1%	Panasonic, Electro Films, FMI, Vishay, etc.
1	R2	130 k $\Omega$ , 1/16 W, $\pm$ 1%	
1	R3	1.5 M $\Omega$ , 1/16 W, $\pm$ 1%	
1	R4	68.1 $\Omega$ , 1/16 W, $\pm$ 1%	
1	R5	60.4 k $\Omega$ , 1/16 W, $\pm$ 1%	
4	R6, R7, R44, R45 <sup>2</sup>	1.8 M $\Omega$ , 1/10 W, $\pm$ 1%	
1	R8	221 k $\Omega$ , 1/16 W, $\pm$ 1%	
1	R10	301 $\Omega$ , 1/16 W, $\pm$ 1%	
1	R12	499 k $\Omega$ , 1/16 W, $\pm$ 1%	
1	R13	1 M $\Omega$ , 1/16 W, $\pm$ 1%	
1	R14	47 $\Omega$ , 1/16 W, $\pm$ 5%	
1	R15	1.69 M $\Omega$ , 1/16 W, $\pm$ 1%	
1	R16	8.2 $\Omega$ , 1/8 W, $\pm$ 1%	
1	R18	3.32 k $\Omega$ , 1/16 W, $\pm$ 1%	
1	R20	2 $\Omega$ , 1/16 W, $\pm$ 5%	
1	R21, R22	6.49 M $\Omega$ , 1/16 W, $\pm$ 1%	
1	R23	10 $\Omega$ , 1/16 W, $\pm$ 5%, or 220 $\mu$ H inductor	
1	R75	261 k $\Omega$ , 1/16 W, $\pm$ 1%	
1	R76	200 k $\Omega$ , 1/16 W, $\pm$ 1%	
1	FB1	600 $\Omega$ , 200 mA ferrite bead	Murata BLM11A601S or similar
1	DB1	S1ZB60 bridge rectifier	Shindengen, Diodes, Inc.
1	SP1	350 V	Bourns (TISP4350H3) or Teccor (P3100SC)
1	Q1	CPC5602 FET	Clare
1	U1	CPC5622 LITELINK	Clare

<sup>1</sup>Use voltage ratings based on the isolation requirements of your application. Typical applications will require 2kV to safely hold off the isolation voltage.

<sup>2</sup>Use components that allow enough space to account for the possibility of high-voltage arcing.

## 2.2 Reactive Termination Application Circuit

www.DataSheet4U.com

Figure 4. Reactive Termination Application Circuit Schematic

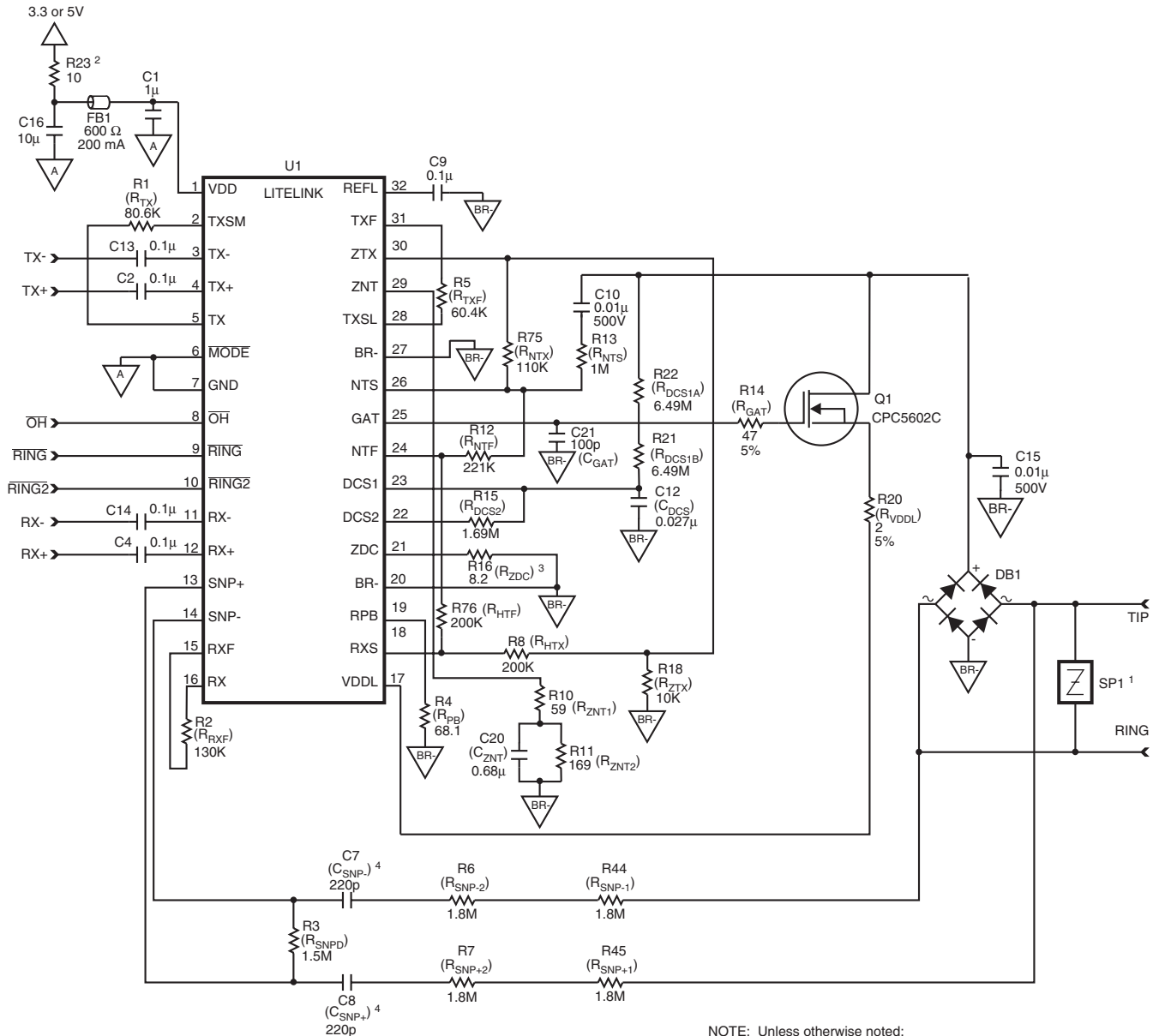

NOTE: Unless otherwise noted:  
Resistor values are in Ohms  
All resistors are 1%.  
Capacitor values are in Farads.

<sup>1</sup>This design was tested and found to comply with FCC Part 68 with this Sidactor. Other compliance requirements may require a different part.

<sup>2</sup>Higher-noise power supplies may require substitution of a 220  $\mu$ H inductor, Toko 380HB-2215 or similar. See the Power Quality section of Clare application note AN-146, [Guidelines for Effective LITELINK Designs](#) for more information.

<sup>3</sup> $R_{ZDC}$  sets the loop-current limit, see ["Setting a Current Limit" on page 13](#). Also see Clare application note AN-146 for heat sinking recommendations for the CPC5602C FET.

<sup>4</sup>Use voltage ratings based on the isolation requirements of your application.

### 2.2.1 Reactive Termination Application Circuit Part List

Quantity	Reference Designator	Description	Supplier
1	C1	1 $\mu$ F, 16 V, $\pm$ 10%	AVX, Murata, Novacap, Panasonic, SMEC, Tecate, etc.
5	C2, C4, C9, C13, C14	0.1 $\mu$ F, 16 V, $\pm$ 10%	
2	C7, C8 <sup>1</sup>	220 pF, $\pm$ 5%	
2	C10, C15	0.01 $\mu$ F, 500 V, $\pm$ 10%	
1	C12	0.027 $\mu$ F, 16 V, $\pm$ 10%	
1	C16	10 $\mu$ F, 16 V, $\pm$ 10%	
1	C20	0.68 $\mu$ F, 16 V, $\pm$ 10%	
1	C21	100 pF, 16 V, 10%	
1	R1	80.6 k $\Omega$ , 1/16 W, $\pm$ 1%	Panasonic, Electro Films, FMI, Vishay, etc.
1	R2	130 k $\Omega$ , 1/16 W, $\pm$ 1%	
1	R3	1.5 M $\Omega$ , 1/16 W, $\pm$ 1%	
1	R4	68.1 $\Omega$ , 1/16 W, $\pm$ 1%	
1	R5	60.4 k $\Omega$ , 1/16 W, $\pm$ 1%	
4	R6, R7, R44, R45 <sup>2</sup>	1.8 M $\Omega$ , 1/10 W, $\pm$ 1%	
1	R8	200 k $\Omega$ , 1/16 W, $\pm$ 1%	
1	R10	59 $\Omega$ , 1/16 W, $\pm$ 1%	
1	R11	169 $\Omega$ , 1/16 W, $\pm$ 1%	
1	R12	221 k $\Omega$ , 1/16 W, $\pm$ 1%	
1	R13	1 M $\Omega$ , 1/16 W, $\pm$ 1%	
1	R14	47 $\Omega$ , 1/16 W, $\pm$ 5%	
1	R15	1.69 M $\Omega$ , 1/16 W, $\pm$ 1%	
1	R16	8.2 $\Omega$ , 1/8 W, $\pm$ 1%	
1	R18	10 k $\Omega$ , 1/16 W, $\pm$ 1%	
1	R20	2 $\Omega$ , 1/16 W, $\pm$ 5%	
1	R21, R22	6.49 M $\Omega$ , 1/16 W, $\pm$ 1%	
1	R23	10 $\Omega$ , 1/16 W, $\pm$ 5%, or 220 $\mu$ H inductor	
1	R75	110 k $\Omega$ , 1/16 W, $\pm$ 1%	
1	R76	200 k $\Omega$ , 1/16 W, $\pm$ 1%	
1	FB1	600 $\Omega$ , 200 mA ferrite bead	Murata BLM11A601S or similar
1	DB1	S1ZB60 bridge rectifier	Shindengen, Diodes, Inc.
1	SP1	350 V	Bourns (TISP4350H3) or Teccor (P3100SC)
1	Q1	CPC5602 FET	Clare
1	U1	CPC5622 LITELINK	

<sup>1</sup>Use voltage ratings based on the isolation requirements of your application. Typical applications will require 2kV to safely hold off the isolation voltage.

<sup>2</sup>Use components that allow enough space to account for the possibility of high-voltage arcing.

### 3. Using LITELINK

[www.DataSheet4U.com](http://www.DataSheet4U.com)

As a full-featured telephone line interface, LITELINK performs the following functions:

- DC termination and V/I slope control
- AC impedance control
- 2-wire to 4-wire conversion (hybrid)
- Current limiting
- Ringing detect signalling reception
- Caller ID signalling reception
- Switch hook

LITELINK can accommodate specific application features without sacrificing basic functionality or performance. Application features include, but are not limited to:

- High transmit power operation
- Pulse dialing
- Ground start
- Loop start
- Parallel telephone off-hook detection (line intrusion)
- Battery reversal detection
- Line presence detection
- World-wide programmable operation

This section of the data sheet describes LITELINK operation in standard configuration for usual operation. Clare offers additional application information on-line ([see Section 5 on page 14](#)) for the following topics:

- Circuit isolation considerations
- Optimizing LITELINK performance
- Data Access Arrangement architecture
- LITELINK circuit descriptions
- Surge protection
- EMI considerations

Other specific application materials are also referenced in this section as appropriate.

#### 3.1 Switch Hook Control (On-hook and Off-hook States)

LITELINK operates in one of two conditions, on-hook and off-hook. In the on-hook condition the telephone line is available for calls. In the off-hook condition the telephone line is engaged. The  $\overline{OH}$  control input is used to place LITELINK in one of these two states.

With  $\overline{OH}$  high, LITELINK is on-hook and ready to make or receive a call. Also while on-hook,

LITELINK's ringing detector and CID amplifiers are both active.

Asserting  $\overline{OH}$  low causes LITELINK to answer or originate a call by entering the off-hook state. In the off-hook state, loop current flows through LITELINK.

#### 3.2 On-hook Operation: $\overline{OH}=1$

The LITELINK application circuit leakage current is less than 10  $\mu\text{A}$  with 100 V across ring and tip, equivalent to greater than 10 M $\Omega$  on-hook resistance.

##### 3.2.1 Ringing Signal Reception via the Snoop Circuit

In the on-hook state ( $\overline{OH}$  not asserted), an internal multiplexer engages the snoop circuitry. This circuit simultaneously monitors the telephone line for two conditions; incoming ringing signal and caller ID data bursts.

Refer to the application schematic diagram ([see Figure 3 on page 6](#)). C7 ( $C_{\text{SNP-}}$ ) and C8 ( $C_{\text{SNP+}}$ ) provide a high-voltage isolation barrier between the telephone line and SNP- and SNP+ input pins of the LITELINK while coupling AC signals to the snoop amplifier. The snoop circuit "snoops" the telephone line continuously while drawing no dc current. In the LITELINK, the incoming ringing signals are compared to a reference level. When the ringing signal exceeds the preset threshold, the internal comparators generate the  $\overline{\text{RING}}$  and  $\overline{\text{RING2}}$  signals which are output from LITELINK at pins 9 and 10, respectively. Selection of which output to use is dependent upon the support logic responsible for monitoring and filtering the ringing detect signals. To reduce or eliminate false ringing detects this signal should be digitally filtered and qualified by the system as a valid ringing signal. A logic low output on  $\overline{\text{RING}}$  or  $\overline{\text{RING2}}$  indicates that the LITELINK ringing signal detect threshold has been exceeded. In the absence of any incoming ac signal the  $\overline{\text{RING}}$  and  $\overline{\text{RING2}}$  outputs are held high.

The CPC5622  $\overline{\text{RING}}$  output signal is generated by a half-wave ringing detector while the  $\overline{\text{RING2}}$  output is generated by a full-wave ringing detector. A half-wave ringing detector's output frequency follows the frequency of the incoming ringing signal from the Central Office (CO) while a full-wave ringing detector's output frequency is twice that of the incoming signal. Because  $\overline{\text{RING}}$  is the output of a half-wave detector, it will output **one** logic low pulse per cycle of the ringing frequency. Also, because the  $\overline{\text{RING2}}$  is the output of a



full-wave detector it will output **two** logic low pulses per cycle of the ringing frequency. Hence, the nomenclature  $\overline{\text{RING2}}$  for twice the output pulses.

The set-up of the ringing detector comparator causes the  $\overline{\text{RING}}$  output pulses to remain low for most of one half-cycle of the ringing signal and remains high for the entire second half-cycle of the ringing signal. For the  $\overline{\text{RING2}}$  output, the pulses remain low during most of both halves of the ringing cycle and returns high for only a short period near the zero-crossing of the ringing signal. Both of the ringing outputs remain high during the silent interval between ringing bursts. Hysteresis is employed in the LITELINK ringing detector circuit to improve noise immunity.

The ringing detection threshold depends on the values of R3 ( $R_{\text{SNPD}}$ ), R6 & R44 ( $R_{\text{SNP-}}$ ), R7 & R45 ( $R_{\text{SNP+}}$ ), C7 ( $C_{\text{SNP-}}$ ), and C8 ( $C_{\text{SNP+}}$ ). The value of these components shown in the application circuits are recommended for typical operation. The ringing detection threshold can be changed according to the following formula:

$$V_{\text{RINGPK}} = \left( \frac{750\text{mV}}{R_{\text{SNPD}}} \right) \sqrt{\left[ (R_{\text{SNP\_TOTAL}} + R_{\text{SNPD}})^2 + \frac{1}{(\pi f_{\text{RING}} C_{\text{SNP}})^2} \right]}$$

Where:

- $R_{\text{SNPD}} = R3$  in the application circuits shown in this data sheet.
- $R_{\text{SNP\_TOTAL}}$  = the total of R6, R7, R44, and R45 in the application circuits shown in this data sheet.
- $C_{\text{SNP}} = C7 = C8$  in the application circuits shown in this data sheet.
- And  $f_{\text{RING}}$  is the frequency of the ringing signal.

Clare Application Note AN-117 **Customize Caller ID Gain and Ring Detect Voltage Threshold** is a spreadsheet for trying different component values in this circuit. Changing the ringing detection threshold will also change the caller ID gain and the timing of the polarity reversal detection pulse, if used.

### 3.2.2 Polarity Reversal Detection in On-hook State

The full-wave ringing detector in the CPC5622 makes it possible to detect tip and ring battery polarity reversal using the  $\overline{\text{RING2}}$  output. When the polarity of the battery voltage applied to tip and ring reverses, a pulse on  $\overline{\text{RING2}}$  indicates the event. The system logic must be able to discriminate a single pulse of approximately 1 msec when using the recommended

external snoop circuit components from a valid ringing signal.

### 3.2.3 On-hook Caller ID Signal Reception

On-hook Caller IDentity (CID) data burst signals are coupled through the snoop components, buffered through LITELINK and output at the RX+ and RX- pins.

In North America, CID data signals are typically sent between the first and second ringing signal while in other countries the CID information may arrive prior to any other signalling state.

In applications that transmit CID after the first ringing burst such as in North American, follow these steps to receive on-hook caller ID data via the LITELINK RX outputs:

1. Detect the first full ringing signal burst on  $\overline{\text{RING}}$  or  $\overline{\text{RING2}}$ .
2. Monitor and process the CID data from the RX outputs.

For applications as in China and Brazil where CID may arrive prior to ringing, follow these steps to receive on-hook caller ID data via the LITELINK RX outputs:

1. Simultaneously monitor for CID data from the RX outputs and for ringing on  $\overline{\text{RING}}$  or  $\overline{\text{RING2}}$ .
2. Process the appropriate signalling data.

Note: Taking LITELINK off-hook (via the  $\overline{\text{OH}}$  pin) disconnects the snoop path from the receive outputs and disables the ringing detector outputs  $\overline{\text{RING}}$  and  $\overline{\text{RING2}}$ .

CID gain from tip and ring to RX+ and RX- is determined by:

$$\text{GAIN}_{\text{CID}}(\text{dB}) = 20\log \left[ \frac{6R_{\text{SNPD}}}{\sqrt{\left[ (R_{\text{SNP\_TOTAL}} + R_{\text{SNPD}})^2 + \frac{1}{(\pi f C_{\text{SNP}})^2} \right]}} \right]$$

Where:

- $R_{\text{SNPD}} = R3$  in the application circuits in this data sheet.
- $R_{\text{SNP\_TOTAL}}$  = the total of R6, R7, R44, and R45 in the application circuits in this data sheet.
- $C_{\text{SNP}} = C7 = C8$  in the application circuits in this data sheet.
- and  $f$  is the frequency of the CID signal

The recommended components in the application circuits yield a gain 0.26 dB at 2000 Hz. Clare Application Note AN-117 [Customize Caller ID Gain and Ring Detect Voltage Threshold](#) is a spreadsheet for trying different component values in this circuit. Changing the CID gain will also change the ringing detection threshold and the timing of the polarity reversal detection pulse, if used.

For single-ended receive applications where only one RX output is used, the snoop circuit gain can be adjusted back to 0 dB by changing the value of the snoop series resistors R6, R7, R44 and R45 from 1.8M $\Omega$  to 715k $\Omega$ . This change results in negligible modification to the ringing detect threshold.

### 3.3 Off-Hook Operation: $\overline{OH}=0$

#### 3.3.1 Receive Signal Path

Signals to and from the telephone network appear on the tip and ring connections of the application circuit. Receive signals are extracted from transmit signals by the LITELINK two-wire to four-wire hybrid then converted to infrared light by the receive path LED. The intensity of the light is modulated by the receive signal and coupled across the electrical isolation barrier to the SELV side photodiode.

On the host equipment (low voltage) side of the barrier, the receive signal is converted by a photodiode into photocurrent. The photocurrent, a linear representation of the receive signal, is amplified and converted to a differential voltage output on RX+ and RX-.

Variations in gain are controlled to within  $\pm 0.4$  dB by factory gain trim.

To accommodate single-supply operation, LITELINK includes a small DC bias on the RX+ and RX- outputs of 1.0 Vdc. Most applications should AC couple the receive outputs as shown in Figure 5.

LITELINK may be used for differential or single-ended output as shown in Figure 5. Single-ended use will produce 6 dB less signal output amplitude. Do not exceed 0 dBm referenced to 600  $\Omega$  (2.2 V<sub>P-P</sub>) signal output level with the standard application circuits. See

application note AN-157, [Increased LITELINK III Transmit Power](#) for more information.

**Figure 5. Differential and Single-ended Receive Path Connections to LITELINK**

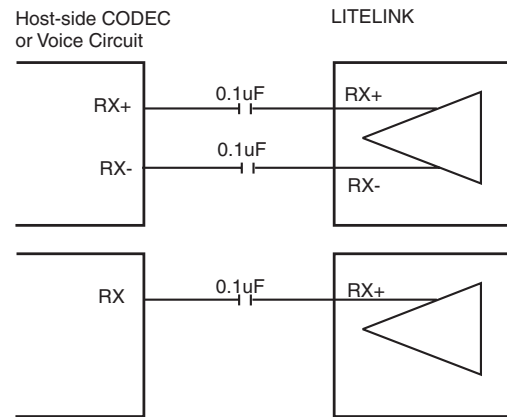

#### 3.3.2 Transmit Signal Path

Transmit signals from the CODEC to the TX+ and TX- pins of LITELINK should be coupled through capacitors as shown in Figure 6 to minimize dc offset errors. Differential transmit signals are converted to single-ended signals within LITELINK then coupled to the optical transmit amplifier in a manner similar to the receive path.

The output of the optical amplifier is coupled to a voltage-to-current converter via a transconductance stage where the transmit signal modulates the telephone line loop current. As in the receive path, the transmit gain is calibrated at the factory, limiting insertion loss to 0  $\pm$  0.4 dB.

Differential and single-ended transmit signals into LITELINK should not exceed a signal level of 0 dBm referenced to 600  $\Omega$  (or 2.2 V<sub>P-P</sub>). For output power levels above 0dBm consult the application note AN-157, [Increased LITELINK III Transmit Power](#) for more information.

**Figure 6. Differential and Single-ended Transmit Path Connections to LITELINK**

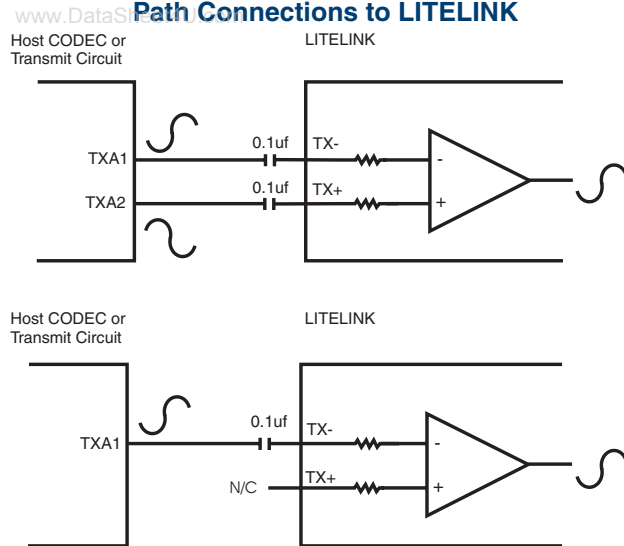

### 3.4 Initialization Requirement Following Power-up

$\overline{\text{OH}}$  must be de-asserted (set logic high) once after power-up for at least 50ms to transfer internal gain trim values within LITELINK. This would be normal operation in most applications. Failure to comply with this requirement will result in transmission gain errors and possibly distortion.

### 3.5 DC Characteristics

The CPC5622 is designed for worldwide applications. Modification of the values of the components at the ZDC, DCS1, and DCS2 pins allow for control of the VI slope characteristics of LITELINK. Selecting appropriate resistor values for  $R_{ZDC}$  (R16) and  $R_{DCS2}$  (R15) in the provided application circuits enable compliance with various DC requirements.

#### 3.5.1 Setting a Current Limit

LITELINK includes a telephone line current limit feature that is selectable by choosing the desired value for  $R_{ZDC}$  (R16) using the following formula:

$$I_{CL} \text{ Amps} = \frac{1V}{R_{ZDC}} + 0.008A$$

Clare recommends using  $8.2 \Omega$  for  $R_{ZDC}$  for most applications, limiting telephone line current to 130 mA.

Whether using the recommended value above or when setting  $R_{ZDC}$  higher for a lower loop current limit

refer to the guidelines for FET thermal management provided in AN-146, [Guidelines for Effective LITELINK Designs](#).

### 3.6 AC Characteristics

#### 3.6.1 Resistive Termination Applications

North American and Japanese telephone line AC termination requirements are met with a resistive  $600 \Omega$  ac 2-wire termination. For these applications LITELINK's 2-wire network termination impedance is set by the resistor  $R_{ZNT}$  (R10) located at the ZNT pin (pin 29) with a value of  $301 \Omega$ .

#### 3.6.2 Reactive Termination Applications

Many countries use a single-pole complex impedance to model the telephone network transmission line characteristic impedance as shown in the table below.

Line Impedance Model

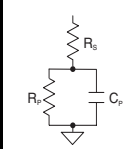
		Australia	China	TBR 21
	$R_S$	220 $\Omega$	200 $\Omega$	270 $\Omega$
	$R_P$	820 $\Omega$	680 $\Omega$	750 $\Omega$
	$C_P$	120 nF	100 nF	150 nF

Proper gain and termination impedance circuits for a complex impedance requires the use of complex network on ZNT as shown in the "[Reactive Termination Application Circuit](#)" on page 8.

#### 3.6.3 $\overline{\text{MODE}}$ Pin Usage

Assert the  $\overline{\text{MODE}}$  pin low ( $\overline{\text{MODE}} = 0$ ) introduces a 7 dB pad into the transmit path and adds 7 dB of gain to the receive path. These changes compensate for the gain changes made to the transmit and receive paths necessary for reactive termination implementations. Overall insertion loss with the reactive termination application circuit and  $\overline{\text{MODE}}$  asserted is 0 dB.

Overall insertion loss with  $\overline{\text{MODE}}$  de-asserted ( $\overline{\text{MODE}} = 1$ ) for the resistive termination application circuit is 0 dB.



## 4. Regulatory Information

[www.DataSheet4U.com](http://www.DataSheet4U.com)

LITELINK III can be used to build products that comply with the requirements of TIA/EIA/IS-968 (formerly FCC part 68), FCC part 15B, TBR-21, EN60950, UL1950, EN55022B, IEC950/IEC60950, CISPR22B, EN55024, and many other standards. LITELINK provides supplementary isolation. Metallic surge requirements are met through the inclusion of a crow bar protection device in the application circuit. Longitudinal surge protection is provided by LITELINK's optical-across-the-barrier technology and the use of high-voltage components in the application circuit as needed.

The information provided in this document is intended to inform the equipment designer but it is not sufficient to assure proper system design or regulatory compliance. Since it is the equipment manufacturer's responsibility to have their equipment properly designed to conform to all relevant regulations, designers using LITELINK are advised to carefully verify that their end-product design complies with all applicable safety, EMC, and other relevant standards and regulations. Semiconductor components are not rated to withstand electrical overstress or electrostatic discharges resulting from inadequate protection measures at the board or system level.

## 5. LITELINK Design Resources

### 5.1 Clare, Inc. Design Resources

The Clare, Inc. web site has a wealth of information useful for designing with LITELINK, including application notes and reference designs that already meet all applicable regulatory requirements. LITELINK data sheets also contains additional application and design information. See the following links:

#### LITELINK datasheets and reference designs

Application note AN-117 **Customize Caller ID Gain and Ring Detect Voltage Threshold**

Application note AN-146, **Guidelines for Effective LITELINK Designs**

Application note AN-155 **Understanding LITELINK Display Feature Signal Routing and Applications**



# 6. LITELINK Performance

www.DataSheet4U.com

The following graphs show LITELINK performance using the North American application circuit shown in this data sheet.

Figure 7. Receive Frequency Response at RX

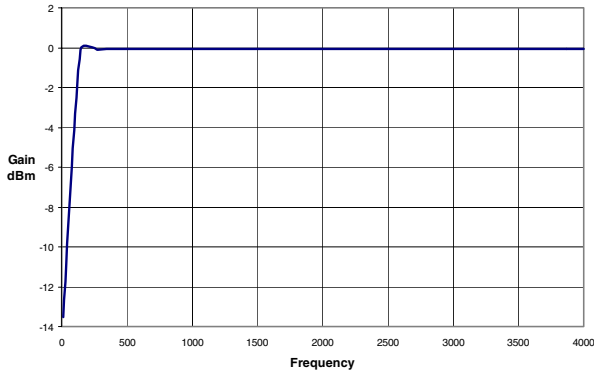

Figure 10. Transmit THD on Tip and Ring

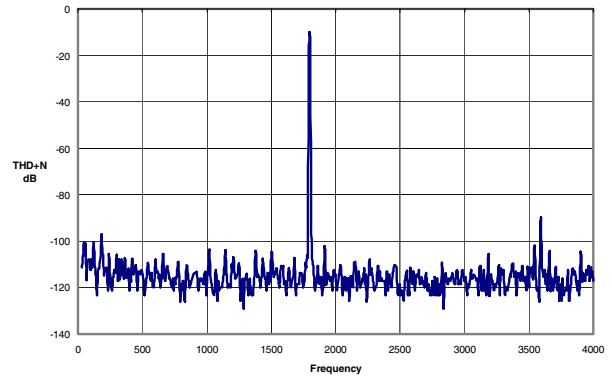

Figure 8. Transmit Frequency Response at TX

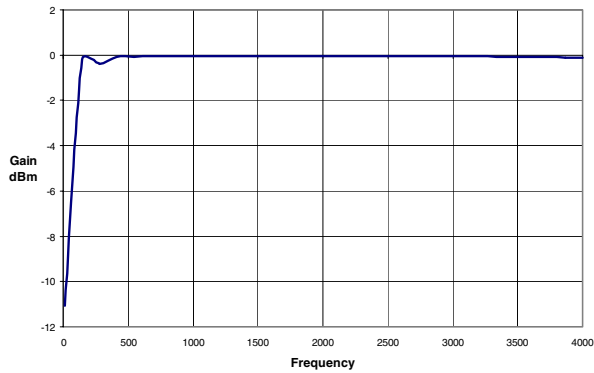

Figure 11. Transhybrid Loss

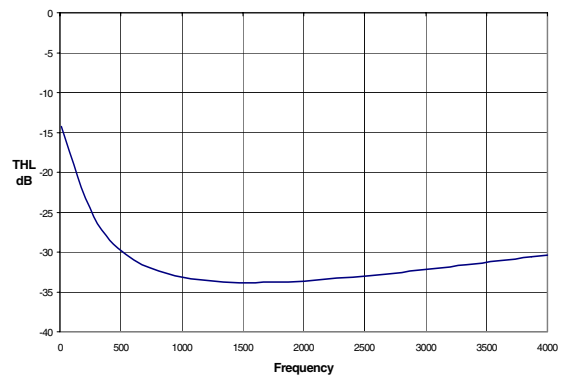

Figure 9. Receive THD on RX

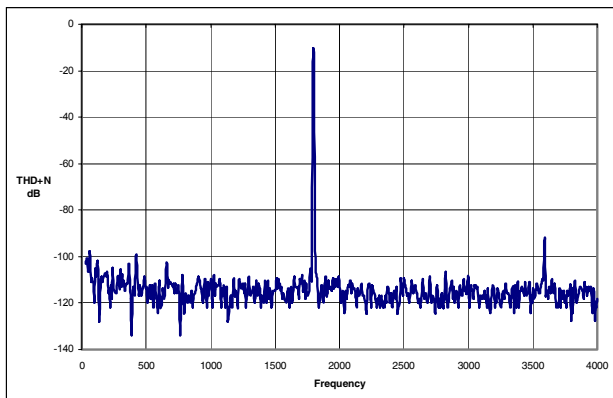
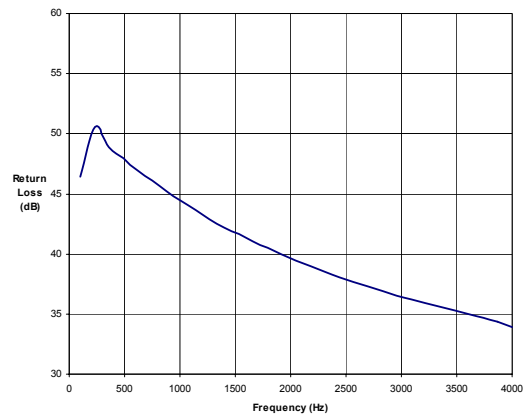
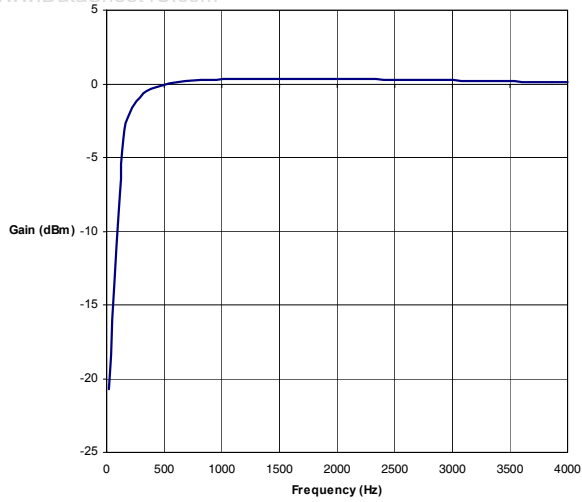

Figure 12. Return Loss

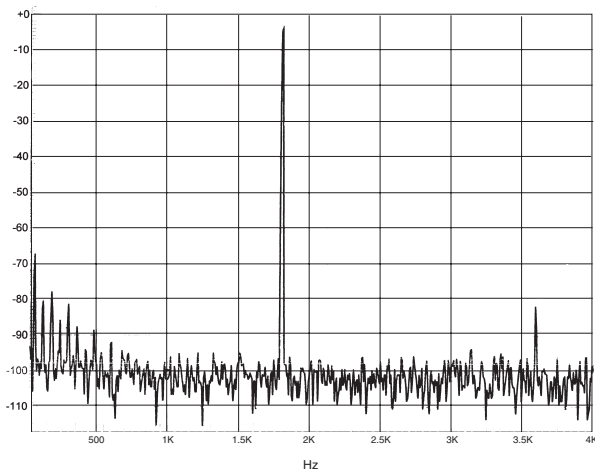

**Figure 13. Snoop Circuit Frequency Response**

www.DataSheet4U.com



**Figure 14. Snoop Circuit THD + N**



**Figure 15. Snoop Circuit Common Mode Rejection**

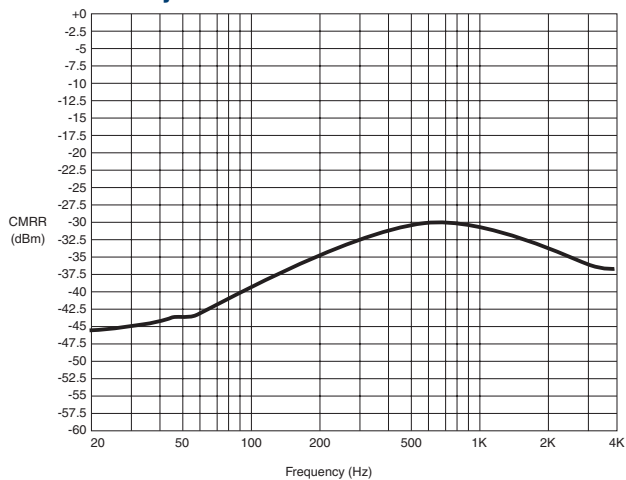

# 7. Manufacturing Information

www.DataSheet4U.com

## 7.1 Mechanical Dimensions

Figure 16. Dimensions

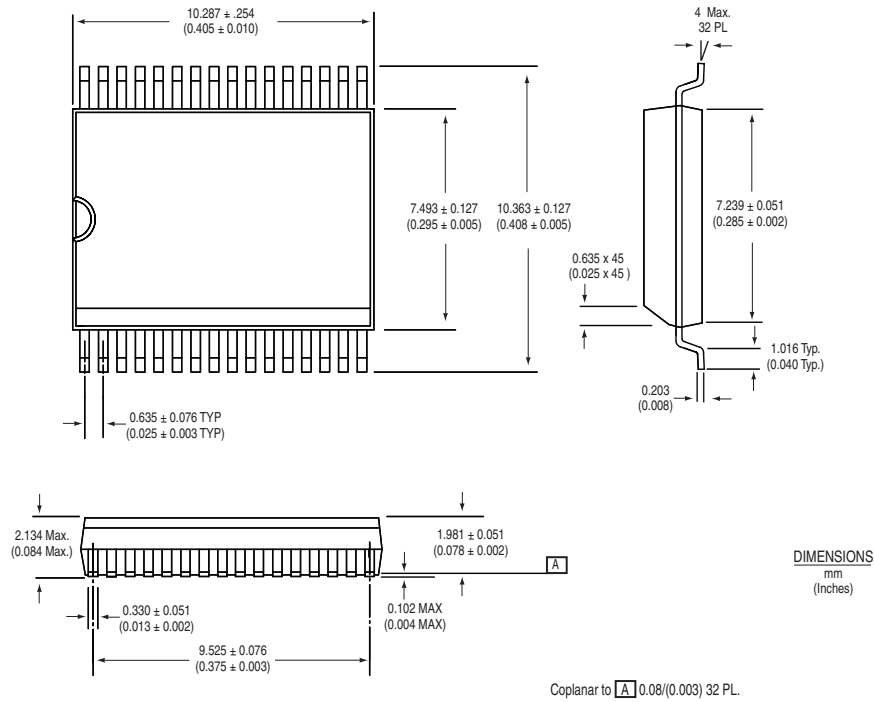
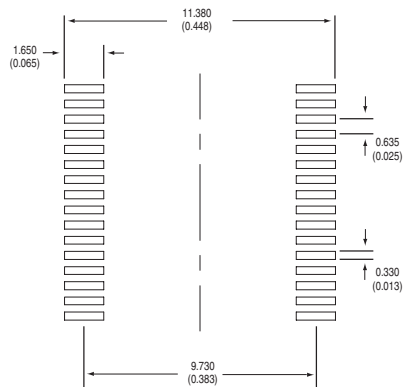

Figure 17. Recommended Printed Circuit Board Layout



## 7.2 Tape and Reel Packaging

www.DataSheet4U.com

Figure 18. Tape and Reel Dimensions

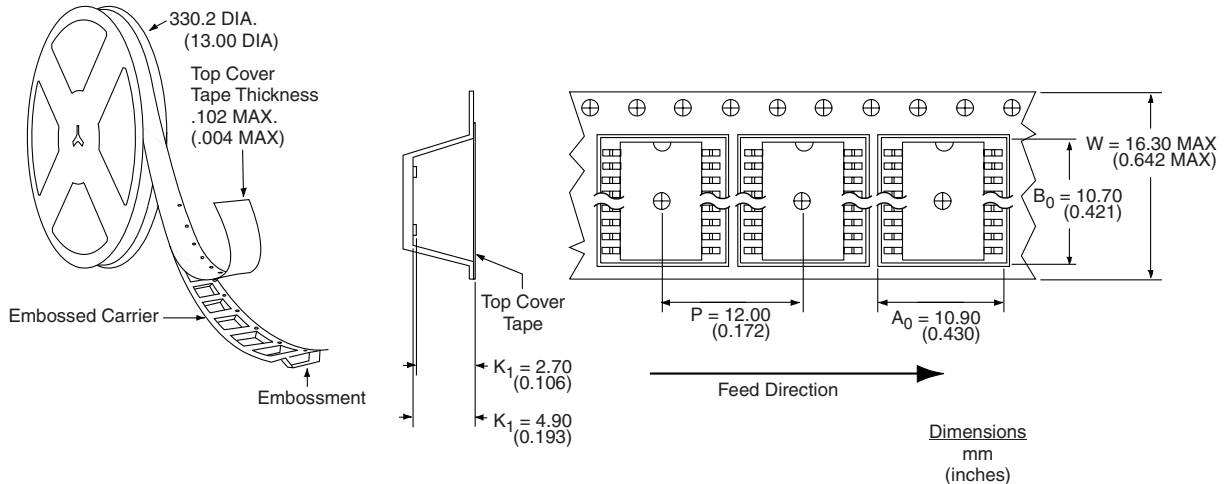

## 7.3 Manufacturing Assembly Processes

### 7.3.1 Moisture Reflow Sensitivity

Clare has characterized the moisture reflow sensitivity of LITELINK using IPC/JEDEC standard J-STD-020. Moisture uptake from atmospheric humidity occurs by diffusion. During the solder reflow process, in which the component is attached to the PCB, the whole body of the component is exposed to high process temperatures. The combination of moisture uptake and high reflow soldering temperatures may lead to moisture induced delamination and cracking of the component. To prevent this, this component must be handled in accordance with IPC/JEDEC standard J-STD-020 per the labelled moisture sensitivity level (MSL), level 3.

### 7.3.2 Reflow Profile

Recommended soldering processes are limited to 245°C component body temperature for 10 seconds.

### 7.3.3 Washing

Ultrasonic cleaning of LITELINK will cause permanent damage to the device. Clare does not recommend ultrasonic cleaning or the use of chlorinated solvents.

For additional information please visit [www.clare.com](http://www.clare.com)

*Clare, Inc. makes no representations or warranties with respect to the accuracy or completeness of the contents of this publication and reserves the right to make changes to specifications and product descriptions at any time without notice. Neither circuit patent licenses or indemnity are expressed or implied. Except as set forth in Clare's Standard Terms and Conditions of Sale, Clare, Inc. assumes no liability whatsoever, and disclaims any express or implied warranty relating to its products, including, but not limited to, the implied warranty of merchantability, fitness for a particular purpose, or infringement of any intellectual property right.*

*The products described in this document are not designed, intended, authorized, or warranted for use as components in systems intended for surgical implant into the body, or in other applications intended to support or sustain life, or where malfunction of Clare's product may result in direct physical harm, injury, or death to a person or severe property or environmental damage. Clare, Inc. reserves the right to discontinue or make changes to its products at any time without notice.*

Specification: DS-CPC5622 - Rev. 1.0

Copyright © 2005, Clare, Inc.

LITELINK® is a registered trademark of Clare, Inc.

All rights reserved. Printed in USA.

2/18/2005

[www.DataSheet4U.com](http://www.DataSheet4U.com)