

eKK6511

**RF Keyboard
Encoder**

**Product
Specification**

DOC. VERSION 1.0

ELAN MICROELECTRONICS CORP.
November 2002

PRELIMINARY

Trademark Acknowledgments:

IBM is a registered trademark and PS/2 is a trademark of IBM.

Windows is a trademark of Microsoft Corporation.

ELAN and ELAN logo  are trademarks of ELAN Microelectronics Corporation.

Copyright © 2005 by ELAN Microelectronics Corporation

All Rights Reserved

Printed in Taiwan

The contents of this specification are subject to change without further notice. ELAN Microelectronics assumes no responsibility concerning the accuracy, adequacy, or completeness of this specification. ELAN Microelectronics makes no commitment to update, or to keep current the information and material contained in this specification. Such information and material may change to conform to each confirmed order.

In no event shall ELAN Microelectronics be made responsible for any claims attributed to errors, omissions, or other inaccuracies in the information or material contained in this specification. ELAN Microelectronics shall not be liable for direct, indirect, special incidental, or consequential damages arising from the use of such information or material.

The software (if any) described in this specification is furnished under a license or nondisclosure agreement, and may be used or copied only in accordance with the terms of such agreement.

ELAN Microelectronics products are not intended for use in life support appliances, devices, or systems. Use of ELAN Microelectronics product in such applications is not supported and is prohibited.

NO PART OF THIS SPECIFICATION MAY BE REPRODUCED OR TRANSMITTED IN ANY FORM OR BY ANY MEANS WITHOUT THE EXPRESSED WRITTEN PERMISSION OF ELAN MICROELECTRONICS.

ELAN MICROELECTRONICS CORPORATION
Headquarters:

No. 12, Innovation Road 1
Hsinchu Science Park
Hsinchu, Taiwan 30077
Tel: +886 3 563-9977
Fax: +886 3 563-9966
<http://www.emc.com.tw>

Hong Kong:

Elan (HK) Microelectronics Corporation, Ltd.
Rm. 1005B, 10/F Empire Centre
68 Mody Road, Tsimshatsui
Kowloon, HONG KONG
Tel: +852 2723-3376
Fax: +852 2723-7780
elanhk@emc.com.hk

USA:

Elan Information Technology Group
1821 Saratoga Ave., Suite 250
Saratoga, CA 95070
USA
Tel: +1 408 366-8223
Fax: +1 408 366-8220

Europe:

Elan Microelectronics Corp. (Europe)
Siewerdtstrasse 105
8050 Zurich, SWITZERLAND
Tel: +41 43 299-4060
Fax: +41 43 299-4079
<http://www.elan-europe.com>

Shenzhen:

Elan Microelectronics Shenzhen, Ltd.
SSMEC Bldg., 3F, Gaoxin S. Ave.
Shenzhen Hi-Tech Industrial Park
Shenzhen, Guangdong, CHINA
Tel: +86 755 2601-0565
Fax: +86 755 2601-0500

Shanghai:

Elan Microelectronics Shanghai Corporation, Ltd.
23/Bldg. #115 Lane 572, Bibo Road
Zhangjiang Hi-Tech Park
Shanghai, CHINA
Tel: +86 021 5080-3866
Fax: +86 021 5080-4600



Contents

1	General Description	1
2	Features	1
3	Application	2
4	Pin Assignment	2
5	Pin Descriptions	3
6	Function Description	4
6.1	Encoder Buffer	4
6.2	Device ID	4
7	Absolute Maximum Ratings	4
8	DC Electrical Characteristics	5
9	AC Electrical Characteristic(Ta=0 ~70 , Vdd=5v, Vss=0v)	5
10	Application Circuit	6
11	Keyboard Arrange Map	8
12	Keyboard Layout	9



Specification Revision History

Doc. Version	Revision Description	Date
1.0	Preliminary version	2002/11/15

PRELIMINARY

1 General Description

In RF keyboard system, that is divided into two parts (the transmitter and the receiver). The eKK6511 micro-controller is dedicated to a RF keyboard encoder for single channel RF transmitter module. The eKK6511 is scanning keyboard state, encode key data and rely on RF Tx module to transmit data.

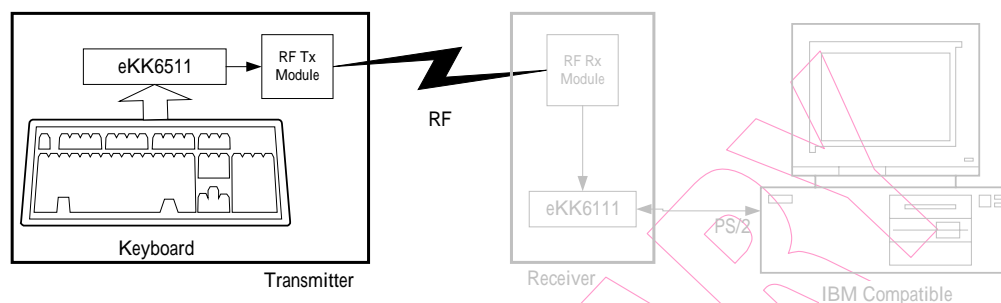

2 Features

- Low cost – eliminate need external components.
- Phantom key detect.
- Resonator oscillator (2.00 MHz)
- Low power CMOS device technology
- Internal pull-up resistor.
- Tri-state outputs for easy board application.
- Built-in 4K ROM.
- Support WINDOWSTM 95, 98, 2000 keys.
- 104/107 keys with multi-media or other special keyboard encoder.
- Support RF transmit module sleep mode (Sleep current under 10 μ A).
- Warm-up time of RF Tx modules: 7.2 μ sec
- Using the device ID to identify which receiver was connected.
 - DIP switch to select. (8 sets ID)
 - Random generate ID (255 sets ID) and store in EEPROM (93LC46)
- Package: 40-pins PDIP, 44-pins QFP

3 Application

- Support the single channel or two channels RF transmitter module.
- IBM PC AT or compatible machine keyboard.
- IBM PS/2 model 30,50,60,80 or compatible machine keyboard.
- Japanese keyboard.
- Korean keyboard.
- Brazilian keyboard.
- European keyboard.

4 Pin Assignment

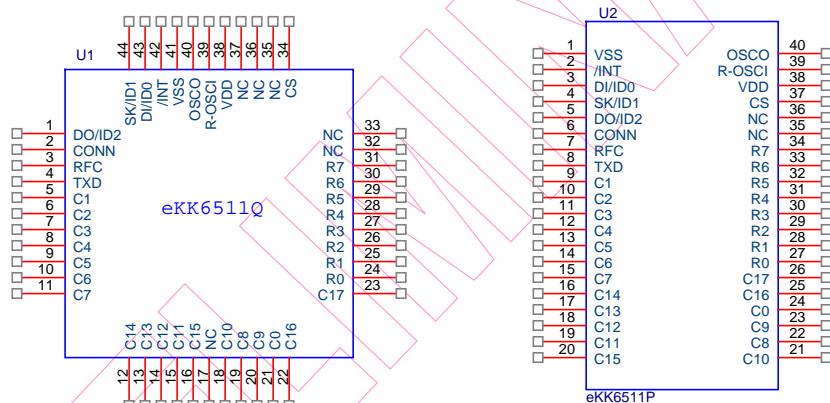



5 Pin Descriptions

Symbol	I/O	Function
P50	O	Column 3 Low output scan line, 3-state
P51	O	Column 4 Low output scan line, 3-state
P52	O	Column 5 Low output scan line, 3-state
P53	O	Column 6 Low output scan line, 3-state
P54	O	Column 7 Low output scan line, 3-state
P55	O	Column 14 Low output scan line, 3-state
P56	O	Column 13 Low output scan line, 3-state
P57	O	Column 12 Low output scan line, 3-state
P80	O	Column 11 Low output scan line, 3-state
P81	O	Column 15 Low output scan line, 3-state
P82	O	Column 10 Low output scan line, 3-state
P83	O	Column 8 Low output scan line, 3-state
P84	O	Column 9 Low output scan line, 3-state
P85	O	Column 0 Low output scan line, 3-state
P86	O	Column 16 Low output scan line, 3-state
P87	O	Column 17 Low output scan line, 3-state
P91	O	Switch DIP control line or Random ID connect bottom
P90	I	Switch DIP for Device ID bit 2 or connect with DO pin of EEPROM
P70	O	Connect with CS pin of EEPROM
P74	I/O	Switch DIP for Device ID bit 1 or connect with SK pin of EEPROM
P75	I/O	Switch DIP for Device ID bit 0 or connect with DI pin of EEPROM
P92	O	Control line for RF Transmitter Module
P93	O	Data Output for RF Transmitter Module connection
P94	O	Column 1 Low output scan line, 3-state
P95	O	Column 2 Low output scan line, 3-state
VSS	I	Ground
P60	I	Row 0 Input Scan line, internal pull high (17K)
P61	I	Row 1 Input Scan line, internal pull high (17K)
P62	I	Row 2 Input Scan line, internal pull high (17K)
P63	I	Row 3 Input Scan line, internal pull high (17K)
P64	I	Row 4 Input Scan line, internal pull high (17K)
P65	I	Row 5 Input Scan line, internal pull high (17K)
P66	I	Row 6 Input Scan line, internal pull high (17K)
P67	I	Row 7 Input Scan line, internal pull high (17K)
VDD	I	+3V Battery power supply
OSCO	O	CLOCK output
OSCI	I	Connect with 2.00MHz Resonator Oscillation



6 Function Description

6.1 Encoder Buffer

The eKK6511 will buffer 24 bytes first-in-first-out order when the system is able to receive scan codes from the keyboard. The eKK6511 generate RF data frame according to FIFO and keyboard status. Then, modulation the data frame into serial signal to RF Tx module. When key pressed, the EKK6511 will generate a make code into FIFO. If key not released, eKK6511 will generate a make code into FIFO every 200ms. When key released, the eKK6511 will generate a break code into FIFO.

6.2 Device ID

The eKK6511 has support two device ID mode:

Controllable ID mode: Using the 3 bits DIP switch to control the device ID.

Random generate ID mode: Using the push bottom to generates a random device ID (255 sets) and restores in EEPROM (93LC46). The eKK6511 will broadcast 10 seconds the new device ID after push bottom released. When battery exchange or reset, the device ID will recovery from EEPROM.

7 Absolute Maximum Ratings

Parameter	Sym.	Ratings
Temperature under bias	TOPR	0 to 70
Storage temperature	TSTR	-65 to 150
Input Voltage	VIN	-0.3V to +6V
Output Voltage	VOUT	-0.3V to +6V



8 DC Electrical Characteristics

Symbol	Parameter	Condition	Min.	Typ.	Max.	Unit
I _{IL}	Input Leakage current	V _{IN} =V _{DD} , V _{SS}			±1	mA
V _{IH}	Input High Voltage		2.0			V
V _{IL}	Input Low Voltage				0.8	V
V _{IHX}	Clock Input High voltage	OSCI	3.5			V
V _{ILX}	Clock Input Low voltage	OSCI			1.5	V
V _{OH1}	Output High voltage (Ports 5,6,8,9 and P74,P75)	I _{OH} =-12.0mA	2.4			V
V _{OH2}	Output High voltage (P70~P72)(S7=0)	I _{OH} =-10.0mA		2		V
V _{OH3}	Output High Voltage (P70~P72)(S7=0)	I _{OH} =-10.0mA	2.4			V
V _{OL1}	Output Low Voltage (ports 5,6,8,9 and P74~P75)	I _{OL} =5.0mA			0.4	V
V _{OL2}	Output Low voltage (P70~P72)(S7=0)	I _{OL} =12.0mA			0.4	V
V _{OL3}	Output Low Voltage (P70~P72)(S7=1)(P76~P77)	I _{OL} =10.0mA		3		V
I _{PH}	Pull-high current	Pull-high active, input pin at V _{SS}	-250	-400	-500	μA
I _{SB}	Power-down current	All input and I/O pin at V _{DD} , output pin floating, WDT enabled			10	mA
I _{CC1}	Operating supply current (V _{DD} =5.0V) at two cycles/two clocks	/RESET=High Fosc=2.00Mhz(CK2="0"), output pin floating			3	mA

9 AC Electrical Characteristic(Ta=0 ~70 , Vdd=5v, Vss=0v)

Symbol	Parameter	Condition	Min.	Typ.	Max.	Unit
D _{CLK}	Input CLK duty cycle		45	50	55	%
T _{TCC}	TCC input period		(T _{ins} +20)/N			ns
T _{WDT}	Watchdog timer period	Ta=25		18		ns
T _{DRH}	Device reset hold period	Ta=25		18		ns

10 Application Circuit

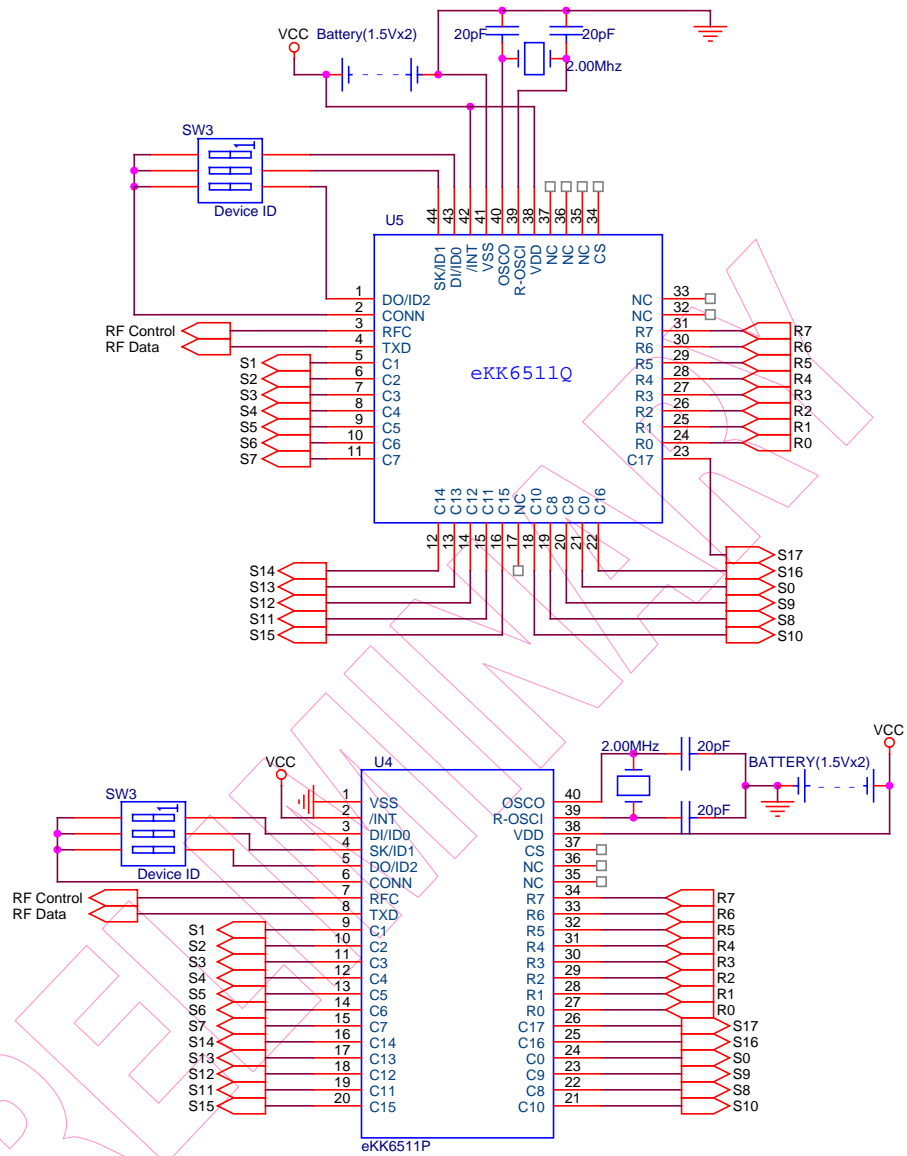

Fig.1 DIP Switch ID mode

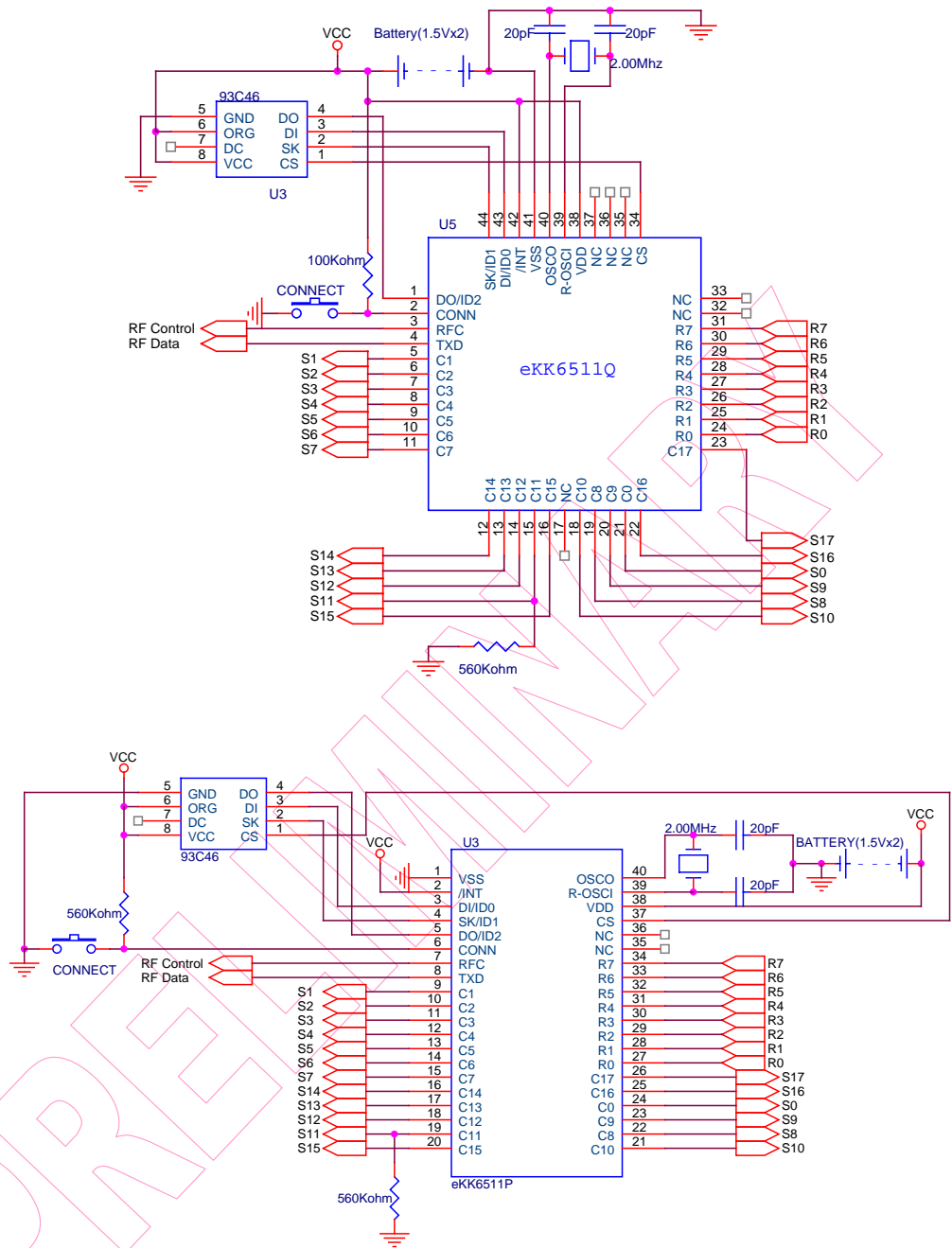

Fig.2 Random generate ID mode



11 Keyboard Arrange Map

	R0	R1	R2	R3	R4	R5	R6	R7
C0	PAUSE 126	POWER		SLEEP	CTRL-R 064	WAKE UP	CTRL-L 058	F5 116
C1	Q 017	TAB 016	A 031	ESC 110	Z 046	N-CHG 131	` (~) 001	1 (!) 002
C2	W 018	CAP 030	S 032	K45 045	X 047	CHG 132	F1 112	2 (@) 003
C3	E 019	F3 114	D 033	F4 115	C 048	ROMA 133	F2 113	3 (#) 004
C4	R 020	T 021	F 034	G 035	V 049	B 050	5 (%) 006	4 (\$) 005
C5	U 023	Y 022	J 037	H 036	M 052	N 051	6 (^) 007	7 (&) 008
C6	I 024] () 028	K 038	F6 117	, (<) 052	K56 056	+ ' (=) 013	8 (*) 009
C7	O 025	F7 118	L 039		. (>) 054	APP APP	F8 119	9 (' ') 010
C8	P 026	[({) 027	; (:) 040	' (") 041	K42 042	/ (?) 055	_ (-) 012	0 (' ') 011
C9	SCROLL 125			ALT-L 060		ALT-R 062		PRINT 124
C10	K14 014	BACK 015	\ () 029	F11 122	ENTER 043	F12 123	F9 120	F10 121
C11	7 (K) 091	4 (K) 092	1 (K) 093	SPACE 061	NUM 090		DEL 076	POWER
C12	8 (K) 096	5 (K) 097	2 (K) 098	0 (K) 099	/ (K) 095		INS	SLEEP
C13	9 (K) 101	6 (K) 102	3 (K) 103	. (K) 104	* (K) 100	- (K) 105	PageUp 085	PageDown 086
C14	+ (K) 106	K107	ENTER (K) 108		Play/Pause 083		HOME 080	END 081
C15	WAKEUP	SHIFT-L 004	SHIFT-R 057	Volume- 057	Volume+ 057	NextTrack 079	PrevTrack 080	Media 081
C16	Mail	WIN-L	WWWForward	WWWStop	WWWBack	WWWRefresh	Mute	WWWSearch
C17	K150 (KC-L)	WWWFavorites	WIN-R	MyComputer	Stop	Calculator	Web/Home	K151 (KC-R)

12 Keyboard Layout

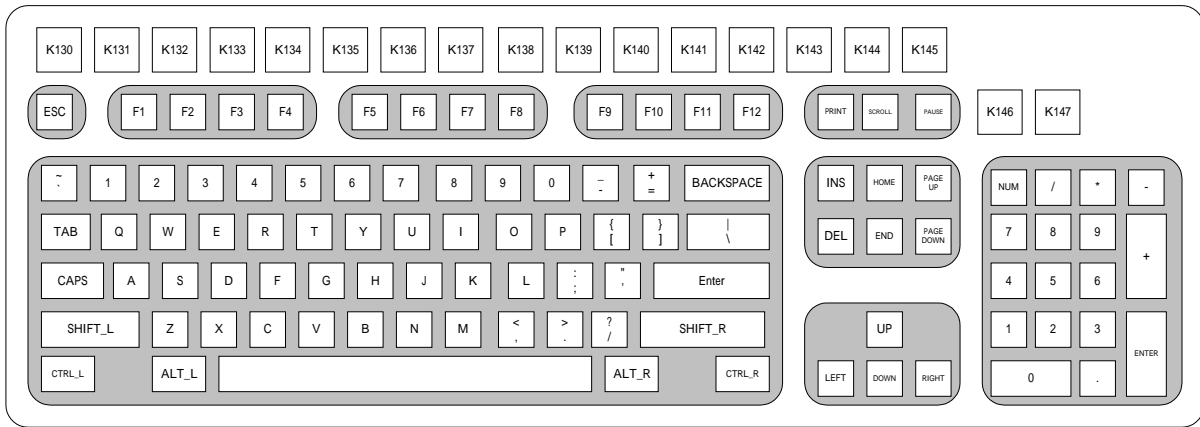

Fig.1 The Windows 2000 keyboard layout.

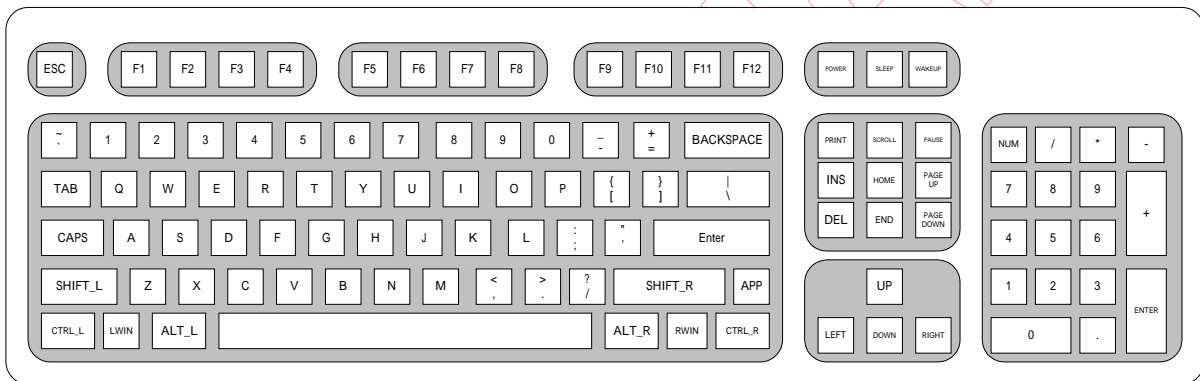

Fig.2 The 107-key keyboard layout

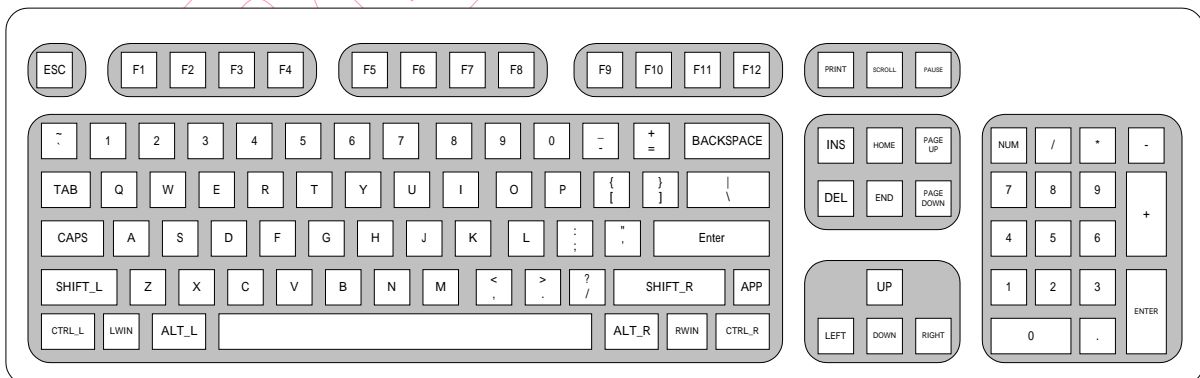

Fig.3. The 104-key keyboard layout



PRELIMINARY