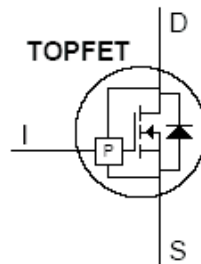
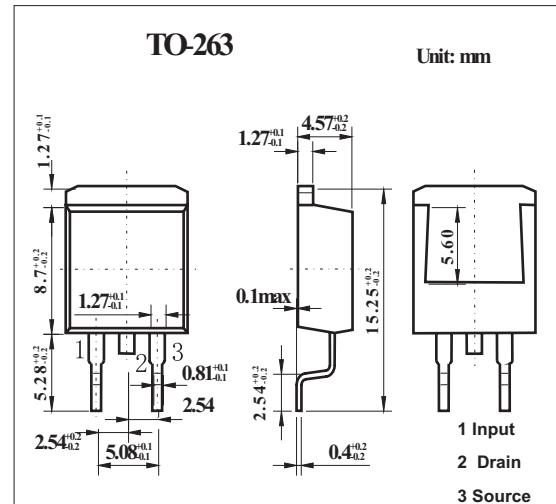

PowerMOS transistor Logic level TOPFET

KUK110-50GL

■ Features

- Vertical power DMOS output stage
- Low on-state resistance
- Overload protection against over temperature
- Overload protection against short circuit load
- Latched overload protection reset by input
- 5 V input level
- Low threshold voltage also allows 5 V control
- Control of power MOSFET
- and supply of overload protection circuits derived from input
- ESD protection on input pin
- Overvoltage clamping for turn off of inductive loads

■ Absolute Maximum Ratings $T_a = 25^\circ\text{C}$

Parameter	Symbol	Rating	Unit
Continuous off-state drain source voltage ¹ $V_{IS} = 0\text{ V}$	V_{DSS}	50	V
Continuous input voltage	V_{IS}	6	V
Continuous drain current *	I_D	45	A
Continuous drain current $T_{mb} \leq 100^\circ\text{C}$; $V_{IS} = 5\text{ V}$	I_D	28	A
Repetitive peak on-state drain current *	I_{DRM}	180	A
Total power dissipation $T_{mb} \leq 25^\circ\text{C}$	P_D	125	W
Storage temperature	T_{stg}	-55 to 150	$^\circ\text{C}$
Continuous junction temperature ²	T_j	150	$^\circ\text{C}$
Lead temperature	T_{sold}	250	$^\circ\text{C}$
Protection supply voltage ³ for valid protection	V_{ISP}	4	V
Protected drain source supply voltage $V_{IS} = 5\text{ V}$	$V_{DDP(T)}$	50	V
Protected drain source supply voltage ⁴ $V_{IS} = 5\text{ V}$	$V_{DDP(P)}$	24	V
Instantaneous overload dissipation $T_{mb} = 25\text{ }^\circ\text{C}$	P_{DSM}	2.1	kW

* $T_{mb} \leq 25^\circ\text{C}$; $V_{IS} = 5\text{ V}$

KUK110-50GL

■ Electrical Characteristics Ta = 25°C

Parameter	Symbol	Testconditions	Min	Typ	Max	Unit
Repetitive peak clamping current	I_{DROM}	$V_{IS} = 0\text{ V}$			45	A
Non-repetitive clamping energy	E_{DSM}	$T_{mb} \leq 25^\circ\text{C}$; $I_{DM} = 25\text{ A}$; $V \leq 25\text{ V}$; inductive load			1	J
Repetitive clamping energy	E_{DRM}	$T_{mb} \leq 85^\circ\text{C}$; $I_{DM} = 16\text{ A}$; $V_{DD} \leq 20\text{ V}$; $f = 250\text{ Hz}$			80	mJ
Electrostatic discharge capacitor voltage	V_C	Human body model; $C = 250\text{ pF}$; $R = 1.5\text{ k}\Omega$			2	kV
Drain-source clamping voltage	$V_{(CL)DSS}$	$V_{IS} = 0\text{ V}$; $I_D = 10\text{ mA}$	50			V
Drain-source clamping voltage	$V_{(CL)DSS}$	$V_{IS} = 0\text{ V}$; $I_{DM} = 4\text{ A}$; $t_p \leq 300\text{ }\mu\text{s}$; $\delta \leq 0.01$			70	V
Zero input voltage drain current	I_{DSS}	$V_{DS} = 12\text{ V}$; $V_{IS} = 0\text{ V}$		0.5	10	μA
Zero input voltage drain current	I_{DSS}	$V_{DS} = 50\text{ V}$; $V_{IS} = 0\text{ V}$		1	20	μA
Zero input voltage drain current	I_{DSS}	$V_{DS} = 40\text{ V}$; $V_{IS} = 0\text{ V}$; $T_j = 125^\circ\text{C}$		10	100	μA
Drain-source on-state resistance	$R_{DS(ON)}$	$I_{DM} = 25\text{ A}$; $V_{IS} = 5\text{ V}$; $t_p \leq 300\text{ }\mu\text{s}$; $\delta \leq 0.01$		30	35	$\text{m}\Omega$
Overload threshold energy	$E_{DS(TO)}$	$T_{mb} = 25^\circ\text{C}$; $L \leq 10\text{ mH}$; $V_{DD} = 13\text{ V}$; $V_{IS} = 5\text{ V}$		1.1		J
Response time	t_{dsc}	$T_{mb} = 25^\circ\text{C}$; $L \leq 10\text{ mH}$; $V_{DD} = 13\text{ V}$; $V_{IS} = 5\text{ V}$		0.8		ms
Threshold junction temperature	$T_{j(TO)}$	$V_{IS} = 5\text{ V}$; from $I_D \geq 2\text{ A}$	150			$^\circ\text{C}$
Input threshold voltage	$V_{IS(TO)}$	$V_{DS} = 5\text{ V}$; $I_D = 1\text{ mA}$	1.0	1.5	2.0	V
Input supply current	I_{IS}	$V_{IS} = 5\text{ V}$; normal operation		0.2	0.35	mA
Protection reset voltage	V_{ISR}		2.0	2.6	3.5	V
Protection reset voltage	V_{ISR}	$T_j = 150^\circ\text{C}$	1.0			
Input supply current	I_{ISL}	$V_{IS} = 5\text{ V}$; protection latched	2	3.8	10	mA
Input clamp voltage	$V_{(BR)IS}$	$I_I = 10\text{ mA}$	6			V
Input series resistance	R_{IG}	to gate of power MOSFET		1.5		$\text{k}\Omega$
Forward transconductance	g_{fs}	$V_{DS} = 10\text{ V}$; $I_{DM} = 25\text{ A}$ $t_p \leq 300\text{ }\mu\text{s}$; $\delta \leq 0.01$	17	28		S
Drain current1	$I_{D(SC)}$	$V_{DS} = 13\text{ V}$; $V_{IS} = 5\text{ V}$		60		A
Turn-on delay time	t_{don}	$V_{DD} = 13\text{ V}$; $V_{IS} = 5\text{ V}$		2		μs
Rise time	t_r	resistive load $R_L = 1.1\text{ }\Omega$		8		
Turn-off delay time	t_{doff}	$V_{DD} = 13\text{ V}$; $V_{IS} = 0\text{ V}$		8		
Fall time	t_f	resistive load $R_L = 1.1\text{ }\Omega$		8		
Turn-on delay time	t_{don}	$V_{DD} = 13\text{ V}$; $V_{IS} = 5\text{ V}$		3.7		
Rise time	t_r	inductive load $I_{DM} = 11\text{ A}$		3.7		
Turn-off delay time	t_{doff}	$V_{DD} = 13\text{ V}$; $V_{IS} = 0\text{ V}$		13		
Fall time	t_f	inductive load $I_{DM} = 11\text{ A}$		1.4		
Continuous forward current	I_S	$T_{mb} \leq 25^\circ\text{C}$; $V_{IS} = 0\text{ V}$			50	A
Forward voltage	V_{SDS}	$I_S = 50\text{ A}$; $V_{IS} = 0\text{ V}$; $t_p = 300\text{ }\mu\text{s}$		1.0	1.5	V
Reverse recovery time	t_{rr}	not applicable				
Internal drain inductance	L_d	Measured from upper edge of tab to centre of die		2.5		nH
Internal source inductance	L_s	Measured from source lead soldering point to source bond pad		7.5		nH
Junction to mounting base	$R_{th\ j-mb}$			0.8	1.0	K/W
Junction to ambient	$R_{th\ j-a}$	minimum footprint FR4 PCB		50		K/W

KUK110-50GL

■ Electrical Characteristics Ta = 25°C

Parameter	Symbol	Testconditons	Min	Typ	Max	Unit
Continuous forward current	I _s	T _{mb} ≤ 25°C; V _{is} = 0 V			26	A
Forward voltage	V _{sDO}	I _s = 26 A; V _{is} = 0 V; t _p = 300 μs		1.0	1.5	V
Reverse recovery time	t _{rr}	not applicable				
Internal drain inductance	L _d	Measured from upper edge of tab to centre of die		2.5		nH
Internal source inductance	L _s	Measured from source lead soldering point to source bond pad		7.5		nH

*1 Continuous input voltage. The specified pulse width is for the drain current.

*2 Continuous drain-source supply voltage. Pulsed input voltage.

*3 Continuous input voltage. Momentary short circuit load connection.