

**Product Specification**  
**S5540340**

GaAs Push Pull, 40 – 550MHz, 34.0dB min. Gain @ 550MHz, 280mA max. @ 24VDC



**FEATURES**

- Excellent linearity
- Superior return loss performance
- Extremely low distortion
- Optimal reliability
- Extremely low noise
- Unconditionally stable under all terminations

**APPLICATION**

- 40 to 550 MHz CATV amplifier systems

**DESCRIPTION**

www.DataSheet4U.com

- Hybrid Push Pull amplifier module employing GaAs die

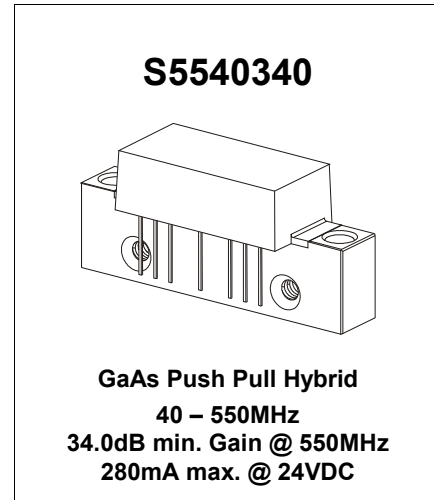

**LIMITING VALUES**

In accordance with the Absolute Maximum Rating System (IEC 60134)

SYMBOL	PARAMETER	MIN.	MAX.	UNIT
$V_i$	RF input voltage (single tone)	-	75	dBmV
$V_{ov}$	DC supply over-voltage (5 minutes)	-	30	V
$T_{stg}$	storage temperature	- 40	+ 100	°C
$T_{mb}$	operating mounting base temperature	- 30	+ 100	°C

**CHARACTERISTICS**

Table 1: S-Parameter, Noise Figure, DC Current;  $V_B = 24V$ ;  $T_{mb} = 30^\circ C$ ;  $Z_S = Z_L = 75 \Omega$

SYMBOL	PARAMETER	CONDITIONS	MIN.	TYP.	MAX.	UNIT
$G_p$	power gain	f = 50 MHz		34.0		dB
		f = 550 MHz	34.0		36.0	dB
SL	slope <sup>1)</sup>	f = 40 to 550 MHz	0.5	1.5	2.0	dB
FL	flatness of frequency response	f = 40 to 550 MHz (Peak to Valley)	-		1.0	dB
$S_{11}$	input return loss	f = 40 to 160 MHz	20.0		-	dB
		f = 160 to 550 MHz	16.0		-	dB
$S_{22}$	output return loss	f = 40 to 160 MHz	20.0		-	dB
		f = 160 to 550 MHz	16.0		-	dB
F	noise figure	f = 50 to 550 MHz	-	-	4.5	dB
$I_{tot}$	total current consumption (DC)			240.0	280.0	mA

Notes:

1) The slope is defined as the difference between the gain at the start frequency and the gain at the stop frequency.

Product Specification  
**S5540340**

GaAs Push Pull, 40 – 550MHz, 34.0dB min. Gain @ 550MHz, 280mA max. @ 24VDC



**CHARACTERISTICS**

Table 2: Distortion data 40 – 550 MHz;  $V_B = 24V$ ;  $T_{mb} = 30^{\circ}C$ ;  $Z_S = Z_L = 75 \Omega$

SYMBOL	CONDITIONS	MIN.	TYP.	MAX.	UNIT
CTB	79 ch. flat; $V_o = 44 \text{ dBmV}^{1)}$	-	-66	- 64	dBc
XMOD	79 ch. flat; $V_o = 44 \text{ dBmV}^{1)}$	-	-62	- 60	dBc
CSO	79 ch. flat; $V_o = 44 \text{ dBmV}^{1)}$	-	-65	- 63	dBc

Notes:

1) 79 channels, NTSC frequency raster: 55.25 MHz to 547.25 MHz, +44 dBmV flat output level.

**Composite Second Order (CSO)**

The CSO parameter (both sum and difference products) is defined by the NCTA.

www.DataSheet4U.com

**Composite Triple Beat (CTB)**

The CTB parameter is defined by the NCTA.

**Cross Modulation (XMOD)**

Cross modulation (XMOD) is measured at baseband (selective voltmeter method), referenced to 100% modulation of the carrier being tested.

Product Specification  
**S5540340**

GaAs Push Pull, 40 – 550MHz, 34.0dB min. Gain @ 550MHz, 280mA max. @ 24VDC

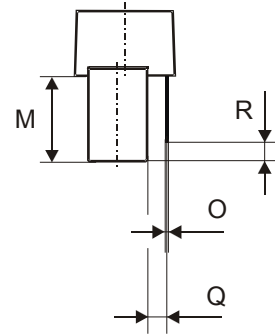
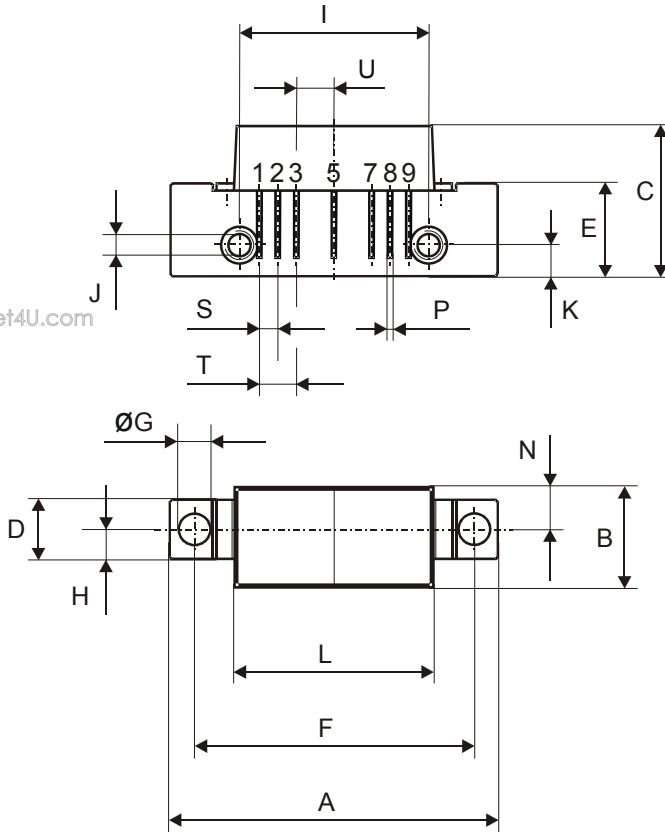

www.DataSheet4U.com

All Dimensions in mm:

	nominal	min	max
A	44,6 ±0,2	44,4	44,8
B	13,6 ±0,2	13,4	13,8
C	20,4 ±0,5	19,9	20,9
D	8 ±0,15	7,85	8,15
E	12,6 ±0,15	12,45	12,75
F	38,1 ±0,2	37,9	38,3
G	4 <sup>+0,2 / -0,05</sup>	3,95	4,2
H	4 ±0,2	3,8	4,2
I	25,4 ±0,2	25,2	25,6
J	UNC 6-32	-	-
K	4,2 ±0,2	4,0	4,4
L	27,2 ±0,2	27,0	27,4
M	11,6 ±0,5	11,1	12,1
N	5,8 ±0,4	5,4	6,2
O	0,25 ±0,02	0,23	0,27
P	0,45 ±0,03	0,42	0,48
Q	2,54 ±0,3	2,24	2,84
R	2,54 ±0,5	2,04	3,04
S	2,54 ±0,25	2,29	2,79
T	5,08 ±0,25	4,83	5,33
U	5,08 ±0,25	4,83	5,33

Pinning:

	1	2	3	4	5	6	7	8	9
INPUT									
GND									
GND									
+VB									
GND									
GND									
OUTPUT									

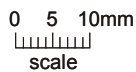

Notes:

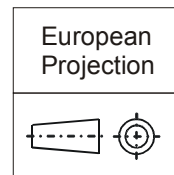

**Product Specification**  
**S5540340**

GaAs Push Pull, 40 – 550MHz, 34.0dB min. Gain @ 550MHz, 280mA max. @ 24VDC



**DEFINITIONS**

<b>Data Sheet Status</b>	
Objective Product Specification	This data sheet contains target or goal specifications for product development.
Preliminary Product Specification	This data sheet contains preliminary data; supplementary data may be published later.
Product Specification	This data sheet contains final product specifications.
<b>Limiting values</b>	
Limiting values given are in accordance with the Absolute Maximum Rating System (IEC 60134). Stress above one or more of the limiting values may cause permanent damage to the device. These are stress ratings only and operation of the device at these or at any other conditions above those given in the Characteristics sections of the specification is not implied. Exposure to limiting values for extended periods may affect device reliability.	
<b>Application information</b>	
Where application information is given, it is advisory and does not form part of the specification.	

Premier Devices reserves the right to make changes without further notice to any products herein. Premier Devices makes no warranty representation or guarantee regarding the suitability of its products for any particular purpose, nor does Premier Devices assume any liability arising out of the application or use of any product or circuit, and specifically disclaims any and all liability, including without limitation consequential or incidental damages. "Typical" parameters which may be provided in Premier Devices datasheets and/or specifications can and do vary in different applications and actual performance may vary over time. All operating parameters, including "Typicals" must be validated for each customer application by customer's technical experts. Premier Devices does not convey any license under its patent rights nor the rights of others. Premier Devices products are not designed, intended, or authorized for use as components in systems intended for surgical implant into the body, or other applications intended to support or sustain life, or for any other application in which the failure of the Premier Devices product could create a situation where personal injury or death may occur. Should Buyer purchase or use Premier Devices products for any such unintended or unauthorized application, Buyer shall indemnify and hold Premier Devices and its officers, employees, subsidiaries, affiliates, and distributors harmless against all claims, costs, damages, and expenses, and reasonable attorney fees arising out of, directly or indirectly, and claim of personal injury or death associated with such unintended or unauthorized use, even if such claim alleges that Premier Devices was negligent regarding the design or manufacture of the part.

© Premier Devices Germany GmbH 2004

How to contact us:



Premier Devices Germany GmbH

Loeffelholzstrasse 20, D-90441 Nuernberg, Germany  
Phone: +49 (0) 911 9411 233, FAX: +49 (0) 911 9411 198,  
Email: [sales.germany@premierdevices.com](mailto:sales.germany@premierdevices.com), Internet: <http://www.premierdevices.de/>