

1. GENERAL DESCRIPTION

The W541C260 is fully compatible with W741C260 in the terms of pin assignment and IC function. It is a high-performance 4-bit microcontroller (μC) with an LCD driver. The device contains a 4-bit ALU, two 8-bit timers, two dividers, a 32×4 LCD driver, and five 4-bit I/O ports (including 1 output port to drive the LEDs). There are also five interrupt sources and 8-level subroutine nesting for interrupt applications. The W541C260 has one power reduction mode to help minimize power dissipation.

The W541C260 has two oscillator circuits and can work in dual-clock or single-clock operation mode. It is suitable for remote controllers, watches and clocks, speech synthesis LSI controllers, and other products.

2. FEATURES

- Operating voltage: 2.4V–5.5V (LCD drive voltage: 3.0V, or 4.5V)
- Single or Dual Clock Mode
 - Single (main oscillator only) or dual clock (both main and sub-oscillator) by mask option .
 - Sub-oscillator is only 32.768 KHz crystal for dual clock mode.
 - Main oscillator is crystal or RC oscillation by mask code option .
 - Main clock : High-frequency clock (400 KHz to 4 MHz) or low-frequency clock (32.768 KHz) is selected by mask code option
- Memory
 - 2048 \times 16 bit program ROM (including 2K \times 4 bit look-up table)
 - 128 \times 4 bit data RAM (including 16 working registers)
 - 32 \times 4 LCD data RAM
- 21 input/output pins
 - Ports for input only: 2 ports/8 pins
 - Input/output ports: 2 ports/8 pins
 - Port for output only: 1 port /4 pins (high sink current to drive LEDs)
 - MFP output pin: 1 pin (MFP)
 - Do not be floating when it is as input or output open-drain (NMOS type).
- Power-down mode
 - Hold function: no operation (except for oscillator)
 - Stop function: no operation (including main clock)
- Five types of interrupts
 - Four internal interrupts (Divider 0, Divider 1, Timer 0, Timer 1)
 - One external interrupt (Port RC)



- LCD driver output
 - 32 segment × 4 common
 - Static, 1/2 duty (1/2 bias), 1/3 duty (1/2 or 1/3 bias), 1/4 duty (1/3 bias) driving mode can be selected
 - LCD driver output pins can be used as DC output ports; selectable by code option
- MFP output pin
 - Output is software selectable as modulating or nonmodulating frequency
 - Works as frequency output specified by Timer 1
- Two built-in 14-bit clock frequency divider circuit (divider 0 and divider 1)
- Two built-in 8-bit programmable countdown timers
 - Timer 0: one of two internal clock frequencies ($F_{osc}/4$ or $F_{osc}/1024$) can be selected
 - Timer 1: includes an auto-reload function; and one of two internal clock frequencies (F_{osc} or $F_{osc}/64$) can be selected or falling edge of pin RC.0 can be selected (output through MFP pin)
- Built-in 18/14-bit watchdog timer selectable for system reset
- Powerful instruction set: 115 instructions
- 8-level subroutine (include interrupt) nesting
- Up to 1 μ S instruction cycle (with 4 MHz operating frequency)
- Packaged in 80-pin QFP

3. BLOCK DIAGRAM

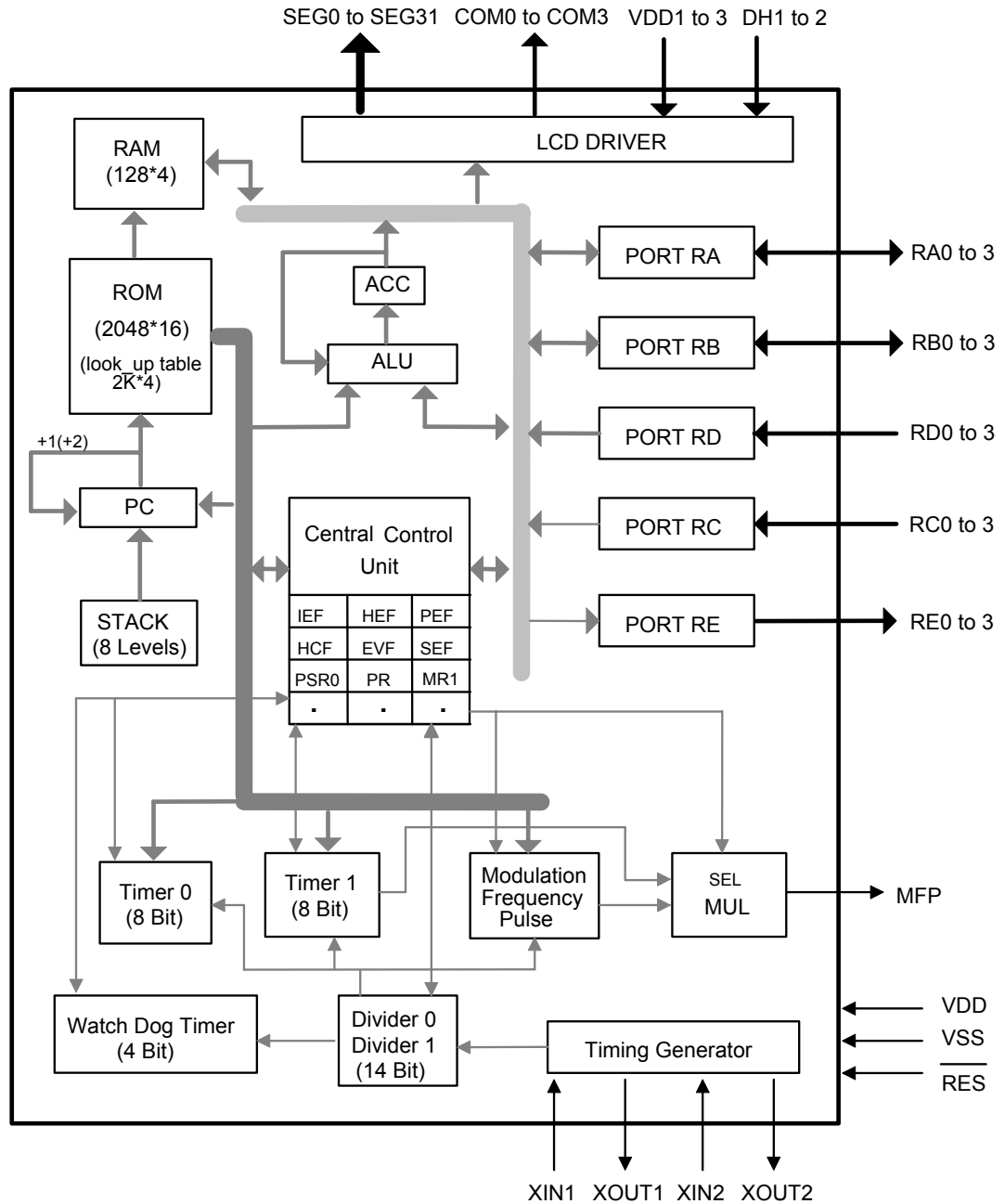

5. PIN DESCRIPTION

SYMBOL	I/O	FUNCTION																									
XIN1	I	Input pin for oscillator. Connected to crystal or resistor to generate system clock by code option. External 10~20pF capacitor uses to get accurate freq in crystal mode.																									
XOUT1	O	Output pin for oscillator. Connected to crystal or resistor to generate system clock by code option. 20pF capacitor is built in internal for crystal mode.																									
XIN2	I	Input pin for sub-oscillator. Connected to a 32.768 KHz crystal. External 10~20pF capacitor uses to get accurate freq in crystal mode.																									
XOUT2	O	Output pin for sub-oscillator. Connected to a 32.768 KHz crystal. 20pF capacitor is built in internal for crystal mode.																									
RA0–RA3	I/O	Input/Output port. Input/output mode specified by port mode 1 register (PM1).																									
RB0–RB3	I/O	Input/Output port. Input/output mode specified by port mode 2 register (PM2).																									
RC0–RC3	I	4-bit port for input only. Each pin has an independent interrupt capability. And Build-in schmitt trigger																									
RD0–RD3	I	4-bit port for input only.																									
RE0–RE3	O	Output port only. This port provides high sink current to drive LEDs.																									
MFP	O	Output pin only. This pin can output modulating or nonmodulating frequency, or Timer 1 clock output specified by mode register 1 (MR1).																									
$\overline{\text{RES}}$	I	System reset pin with pull-high resistor.																									
SEG0–SEG31	O	LCD segment output pins. Can also be used as DC output ports specified by code option.																									
COM0–COM3	O	LCD common signal output pins. <table border="1" data-bbox="527 1396 1117 1606"> <thead> <tr> <th></th> <th>Static</th> <th>1/2 Duty</th> <th>1/3 Duty</th> <th>1/4 Duty</th> </tr> </thead> <tbody> <tr> <td>COM0</td> <td>Used</td> <td>Used</td> <td>Used</td> <td>Used</td> </tr> <tr> <td>COM1</td> <td>Not Used</td> <td>Used</td> <td>Used</td> <td>Used</td> </tr> <tr> <td>COM2</td> <td>Not Used</td> <td>Not Used</td> <td>Used</td> <td>Used</td> </tr> <tr> <td>COM3</td> <td>Not Used</td> <td>Not Used</td> <td>Not Used</td> <td>Used</td> </tr> </tbody> </table> <p>The LCD alternating frequency can be selected by code option.</p>		Static	1/2 Duty	1/3 Duty	1/4 Duty	COM0	Used	Used	Used	Used	COM1	Not Used	Used	Used	Used	COM2	Not Used	Not Used	Used	Used	COM3	Not Used	Not Used	Not Used	Used
	Static	1/2 Duty	1/3 Duty	1/4 Duty																							
COM0	Used	Used	Used	Used																							
COM1	Not Used	Used	Used	Used																							
COM2	Not Used	Not Used	Used	Used																							
COM3	Not Used	Not Used	Not Used	Used																							
DH1, DH2	I	Connection terminals for voltage doubler (halver) capacitor.																									
VDD1, VDD2 VDD3	I	Positive (+) supply voltage terminal. Refer to Functional Description.																									
VDD	I	Positive power supply (+).																									
VSS	I	Negative power supply (-).																									

6. ELECTRICAL CHARACTERISTICS

6.1 Absolute Maximum Ratings

PARAMETER	RATING	UNIT
Supply Voltage to Ground Potential	-0.3 to +7.0	V
Applied Input/Output Voltage	-0.3 to +7.0	V
Power Dissipation	120	mW
Ambient Operating Temperature	0 to +70	°C
Storage Temperature	-55 to +150	°C

Note: Exposure to conditions beyond those listed under Absolute Maximum Ratings may adversely affect the life and reliability of the device.

6.2 DC Characteristics

($V_{DD}-V_{SS} = 3.0V$, $F_m = 4\text{ MHz}$, $F_s = 32.768\text{ KHz}$, $T_A = 25^\circ\text{ C}$, LCD on; unless otherwise specified)

PARAMETER	SYM.	CONDITIONS	MIN.	TYP.	MAX.	UNIT
Op. Voltage	VDD	-	2.4	-	5.5	V
Op. Current (Crystal Type)	IOP1	No load (Ext-V) In dual-clock normal operation	-	0.6	2.5	mA
Op. Current (RC Type)	IOP2	No load (Ext-V) In dual-clock normal operation	-	1	4	mA
Op. Current (Crystal Type)	IOP3	No load (Ext-V) In dual-clock slow operation and F_m is stopped	-	8.5	20	μA
Hold Current (Crystal Type)	IHM1	Hold mode No load (Ext-V) In dual-clock normal operation	-	280	450	μA
Hold Current (RC Type)	IHM2	Hold mode No load (Ext-V) In dual-clock normal operation	-	500	600	μA
Hold Current (Crystal Type)	IHM3	Hold mode No load (Ext-V) In dual-clock slow operation and F_m is stopped	-	4.0	6	μA
Stop Current (Crystal)	ISM	Stop mode No load (Ext-V) In single-clock operating	-	0.1	2	μA
Input Low Voltage	VIL	-	VSS	-	0.3VDD	V
Input High Voltage	VIH	-	0.7VDD	-	VDD	V

DC Characteristics, continue

PARAMETER	SYM.	CONDITIONS	MIN.	TYP.	MAX.	UNIT
MFP Output Low Voltage	VML	IOL = 2.7 mA	-	-	0.4	V
MFP Output High Voltage	VMH	IOH = 3.5 mA	2.4	-	-	V
Port RA, RB Output Low Voltage	VABL	IOL = 2.0 mA	-	-	0.4	V
Port RA, RB Output High Voltage	VABH	IOH = 2.0 mA	2.4	-	-	V
LCD Supply Current	ILCD	All Seg. ON	-	-	6	μA
SEG0–SEG31 Sink Current (Used as LCD Output)	IOL1	VOL = 0.4V VLCD = 0.0V	0.4	-	-	μA
SEG0–SEG31 Drive Current (Used as LCD Output)	IOH1	VOH = 2.4V VLCD = 3.0V	0.3	-	-	μA
Segment Output Low Voltage (Used as DC Output)	VSL	IOL = 0.6 mA	-	-	0.4	V
Segment Output High Voltage (Used as DC Output)	VSH	IOH = 3 μA	2.4	-	-	V
Port RE Sink Current	IEL	VOL = 0.9V	7.5	-	-	mA
Port RE Source Current	IEH	VOH = 2.4V	0.4	1.2	-	mA
Pull-up Resistor	RCD	Port RC, RD	100	350	1000	KΩ
RES Pull-up Resistor	RRES	-	20	100	500	KΩ

6.3 AC Characteristics

(VDD–VSS = 3.0V, Fm = 4 MHz, Fs = 32.768 KHz, TA = 25° C, LCD on; unless otherwise specified)

PARAMETER	SYM.	CONDITIONS	MIN.	TYP.	MAX.	UNIT
Op. Frequency	FOSC	RC type	-	-	4000	KHz
		Crystal type 1 (Option low speed type)	-	32.768	-	
		Crystal type 2 (Option high speed type)	400	-	3580	
Frequency Deviation by Voltage Drop for RC Oscillator	$\frac{\Delta f}{f}$	$\frac{f(3V) - f(2.4V)}{f(3V)}$	-	-	10	%
Instruction Cycle Time	Ti	One machine cycle	-	4/FOSC	-	mS
Reset Active Width	TRAW	FOSC = 32.768 KHz	1	-	-	μS
Interrupt Active Width	TIAW	FOSC = 32.768 KHz	1	-	-	μS

7. APPLICATION CIRCUIT

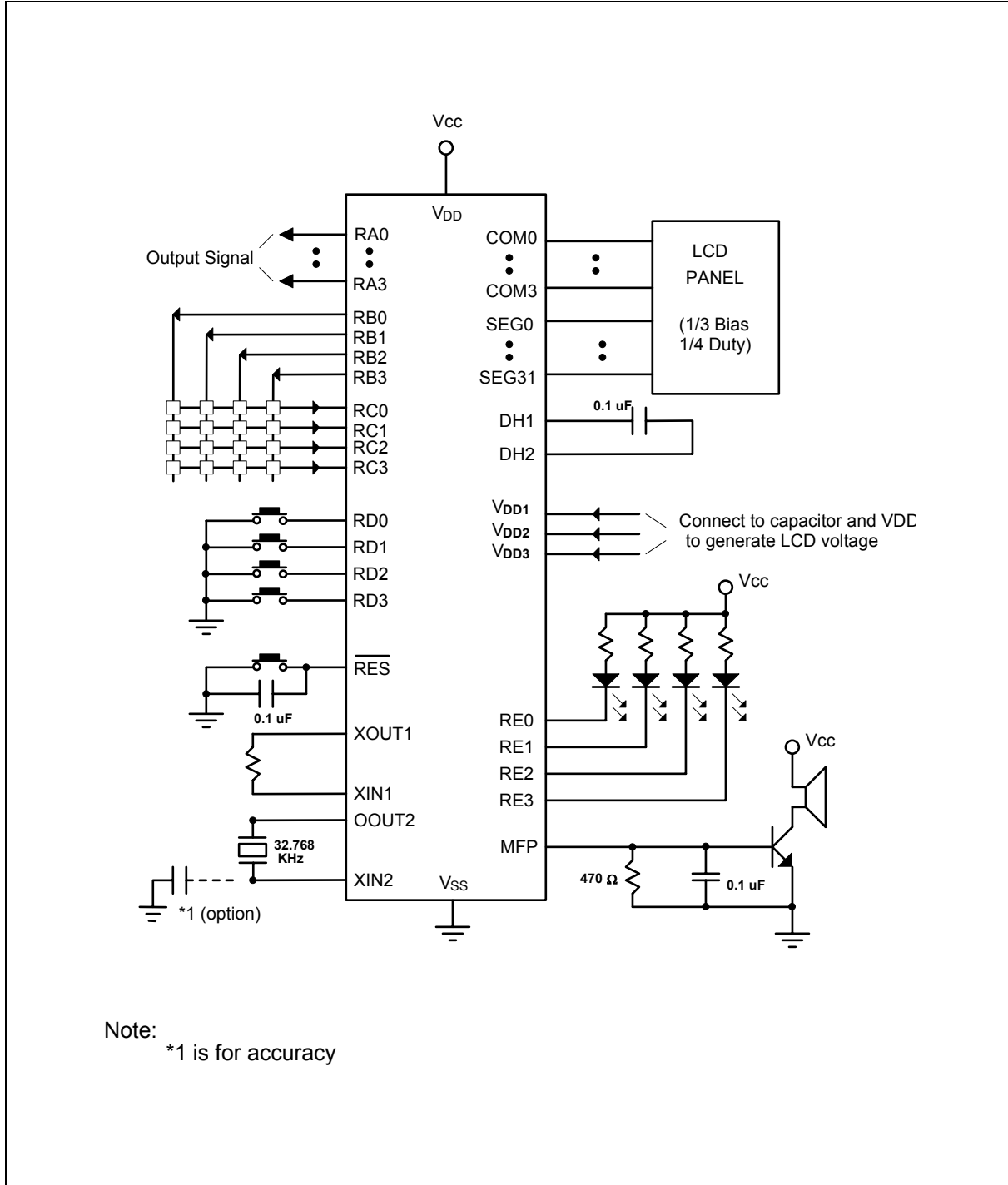



8. REVISION HISTORY

VERSION	DATE	DESCRIPTION
A2	-	Note: Update Hi freq range from 4.19 3.58 MHz
A3	-	Note: RC is built-in schmitt trigger
A4	May 29, 2003	Note: Do not be floating when it is as input or output open-drain (NMOS type)



Headquarters
 No. 4, Creation Rd. III,
 Science-Based Industrial Park,
 Hsinchu, Taiwan
 TEL: 886-3-5770066
 FAX: 886-3-5665577
<http://www.winbond.com.tw/>

Taipei Office
 9F, No.480, Rueiguang Rd.,
 Neihu District, Taipei, 114,
 Taiwan, R.O.C.
 TEL: 886-2-8177-7168
 FAX: 886-2-8751-3579

Winbond Electronics Corporation America
 2727 North First Street, San Jose,
 CA 95134, U.S.A.
 TEL: 1-408-9436666
 FAX: 1-408-5441798

Winbond Electronics Corporation Japan
 7F Daini-ueno BLDG, 3-7-18
 Shinyokohama Kohoku-ku,
 Yokohama, 222-0033
 TEL: 81-45-4781881
 FAX: 81-45-4781800

Winbond Electronics (Shanghai) Ltd.
 27F, 2299 Yan An W. Rd. Shanghai,
 200336 China
 TEL: 86-21-62365999
 FAX: 86-21-62365998

Winbond Electronics (H.K.) Ltd.
 Unit 9-15, 22F, Millennium City,
 No. 378 Kwun Tong Rd.,
 Kowloon, Hong Kong
 TEL: 852-27513100
 FAX: 852-27552064

*Please note that all data and specifications are subject to change without notice.
 All the trade marks of products and companies mentioned in this data sheet belong to their respective owners.*