

# XC6603 Series

ETR03070-003

1A, 0.5V Low Input Voltage, High Speed LDO Regulator  
(Adjustable Soft-start time with an external component)

## ■ GENERAL DESCRIPTION

The XC6603 series is a low voltage input (0.5V) operation and provides high accuracy  $\pm 15\text{mV} / \pm 20\text{mV}$  and can supply large current efficiently due to its ultra low on-resistance even at low output voltages.

The series is ideally suited to the applications which require high current in low input/output voltages and consists of a N-ch driver transistor, a voltage reference, an error amplifier, a current limiter, a foldback circuit, a thermal shutdown (TSD) circuit, an under voltage lock out (UVLO) circuit, a soft-start circuit and a phase compensation circuit.

Output voltage is selectable in 0.1V increments within a range of 0.5V to 1.8V using laser trimming technology and ceramic capacitors can be used for the output stabilization capacitor ( $C_L$ ). The inrush current ( $I_{RUSH}$ ) from  $V_{IN}$  to  $V_{OUT}$  for charging  $C_L$  at start-up can be reduced and makes the  $V_{IN}$  stable. Soft-start time can be adjustable with connecting a capacitor to the SS pin. The inrush current conflicts with the soft-start time, therefore if soft-start is set longer, the inrush current is decreased.

The CE function enables the output to be turned off and the series to be put in stand-by mode resulting in greatly reduced power consumption. At the time of entering the stand-by mode, the series enables the electric charge at the output capacitor ( $C_L$ ) to be discharged via the internal switch. As a result the  $V_{OUT}$  pin quickly returns to the  $V_{SS}$  level.

The CE pull-down function keeps the IC to be in stand-by mode even if the CE pin is left open.

## ■ APPLICATIONS

- Smart phones / Mobile phones
- Digital still cameras / Camcorders
- Note PCs / Tablet PCs
- E-book Readers / Electronic dictionaries
- Wireless LAN

## ■ FEATURES

Maximum Output Current	: 1A (1.3A Limit)
ON Resistance	: $0.15\Omega @ V_{BIAS}=3.6\text{V}, V_{OUT}=1.2\text{V}$
Bias Voltage Range	: 2.5V ~ 6.0V
Input Voltage Range	: 0.5V ~ 3.0V
Output Voltage Range	: 0.5V ~ 1.8V (0.1V increments)
Output Voltage Accuracy	: $\pm 0.015\text{V} @ V_{OUT} < 1.2\text{V}$ $\pm 0.020\text{V} @ V_{OUT} \geq 1.2\text{V}$
Ripple Rejection	: $60\text{dB} @ f=1\text{kHz} (V_{BIAS\_PSRR})$ $75\text{dB} @ f=1\text{kHz} (V_{IN\_PSRR})$
Low Power Consumption	: $100\mu\text{A} (V_{BIAS}), 6.5\mu\text{A} (V_{IN}) @ V_{OUT}=1.2\text{V}$
Stand-by Current	: $0.01\mu\text{A} (V_{BIAS}), 0.01\mu\text{A} (V_{IN})$
Under-voltage Lockout	: 1.8V ( $V_{BIAS}$ ), 0.4V ( $V_{IN}$ )
Thermal Shutdown	: $150^\circ\text{C} @ \text{detect}, 125^\circ\text{C} @ \text{release}$
Protection Circuit	: Foldback Current Limit, TSD, UVLO
Function	: Adjustable Soft-start time with an external component CE Pull-Down (Active High) $C_L$ Auto Discharge
Output Capacitor	: Ceramic Capacitor Compatible ( $2.2\mu\text{F}$ )
Operating Ambient Temperature	: $-40^\circ\text{C} \sim 85^\circ\text{C}$
Packages	: USP-6C, SOT-26W
Environmentally Friendly	: EU RoHS Compliant, Pb Free

## ■ TYPICAL APPLICATION CIRCUIT

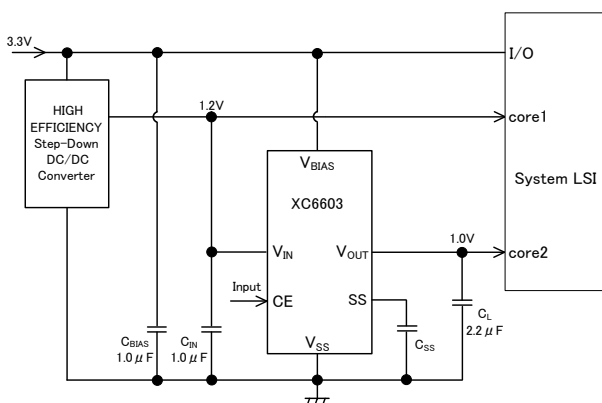

## ■ TYPICAL PERFORMANCE CHARACTERISTICS

XC6603A121xR-G

$V_{BIAS}=3.6\text{V}, V_{CE}=0\text{V} \rightarrow 3.6\text{V} (tr=5\mu\text{s}), V_{IN}=1.5\text{V}$   
 $I_{OUT}=100\text{mA}, C_{BIAS}=C_{IN}=1.0\mu\text{F}, C_L=2.2\mu\text{F}, T_a=25^\circ\text{C}$

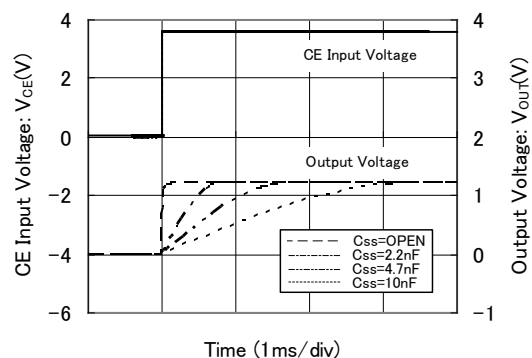

## ■ BLOCK DIAGRAMS

Type A

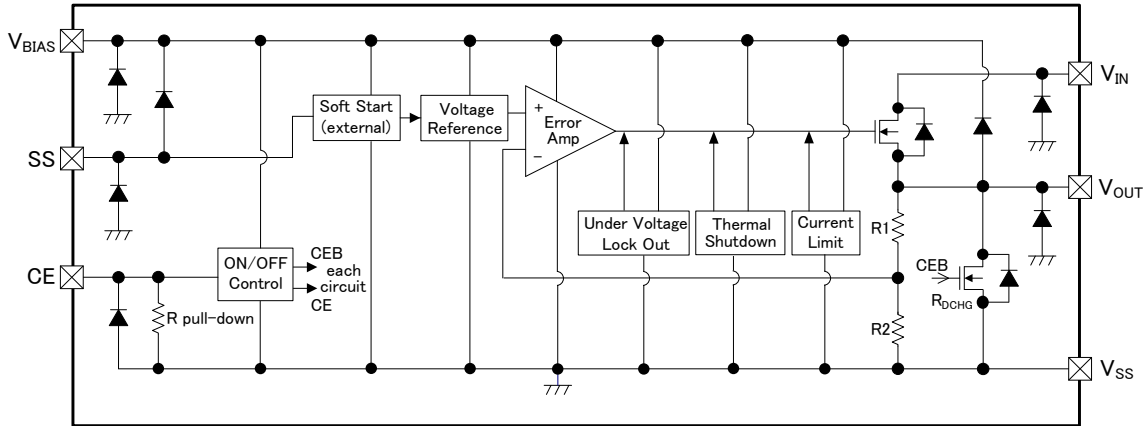

## ■ PRODUCT CLASSIFICATION

### ● Ordering Information

XC6603①②③④⑤⑥-⑦

DESIGNATOR	ITEM	SYMBOL	DESCRIPTION
①	Type	A	Refer to Selection Guide
②③	Output Voltage	05~18	e.g. 1.2V → ②=1, ③=2
④	Output Voltage Accuracy	1	±0.015V (V <sub>OUT</sub> <1.2V), ±0.020V (V <sub>OUT</sub> ≥1.2V)
⑤⑥-⑦ (*1)	Packages (Order Unit)	ER-G	USP-6C (3,000/Reel)
		MR-G	SOT-26W (3,000/Reel)

(\*1) The "-G" suffix denotes Halogen and Antimony free as well as being fully EU RoHS compliant.

### ● Selection Guide

TYPE	SOFT-START	CURRENT LIMITER	THERMAL SHUTDOWN	UVLO	CE PULL-DOWN RESISTOR	C <sub>L</sub> AUTO DISCHARGE
A	Adjustable	Yes	Yes	Yes	Yes	Yes

## ■ PIN CONFIGURATION

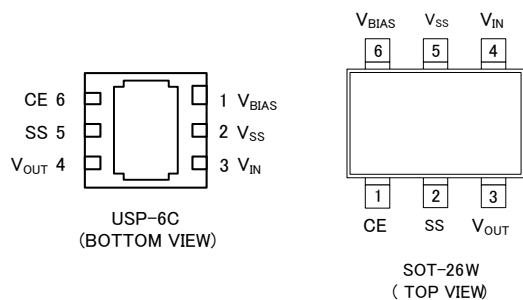

\*The dissipation pad for the USP-6C package should be solder-plated in recommended mount pattern and metal masking so as to enhance mounting strength and heat release. If the pad needs to be connected to other pins, it should be connected to the  $V_{SS}$  (No. 2) pin.

## ■ PIN ASSIGNMENT

PIN NUMBER		PIN NAME	FUNCTIONS
USP-6C	SOT-26W		
1	6	$V_{BIAS}$	Power Supply Input
3	4	$V_{IN}$	Driver Transistor Input
4	3	$V_{OUT}$	Output
5	2	SS	Soft-Start Capacitor Connection
2	5	$V_{SS}$	Ground
6	1	CE	ON/OFF Control

## ■ FUNCTION CHART

PIN NAME	SIGNAL	STATUS
CE	L	Stand-by
	H	Active
	OPEN	Stand-by

## ■ ABSOLUTE MAXIMUM RATINGS

Ta=25°C

PARAMETER		SYMBOL	RATINGS	UNITS
Bias Voltage		V <sub>BIAS</sub>	-0.3 ~ 6.5	V
Input Voltage		V <sub>IN</sub>	-0.3 ~ 6.5	V
Output Current		I <sub>OUT</sub>	1.65 <sup>(*1)</sup>	A
Output Voltage <sup>(*2)</sup>		V <sub>OUT</sub>	-0.3 ~ V <sub>BIAS</sub> +0.3 or 6.5	V
			-0.3 ~ V <sub>IN</sub> +0.3 or 6.5	
CE Input Voltage		V <sub>CE</sub>	-0.3 ~ 6.5	V
SS Pin Voltage <sup>(*3)</sup>		SS	-0.3 ~ V <sub>BIAS</sub> +0.3 or 6.5	V
Power Dissipation	USP-6C	Pd	120	mW
			1000 (PCB mounted) <sup>(*4)</sup>	
	SOT-26W		250	
			600 (PCB mounted) <sup>(*4)</sup>	
Operating Ambient Temperature		T <sub>opr</sub>	-40 ~ 85	°C
Storage Temperature		T <sub>stg</sub>	-55 ~ 125	°C

\* All voltages are described based on the V<sub>SS</sub> pin.

(\*1)  $I_{OUT} \leq Pd / (V_{IN} - V_{OUT})$

(\*2) The maximum value should be either V<sub>BIAS</sub>+0.3V, V<sub>IN</sub>+0.3V or 6.5V in the lowest.

(\*3) The maximum value should be either V<sub>BIAS</sub>+0.3V or +6.5V in the lowest.

(\*4) The power dissipation measured with the test board condition is listed as reference data.

## ELECTRICAL CHARACTERISTICS

Ta=25°C

PARAMETER	SYMBOL	CONDITIONS	MIN.	TYP.	MAX.	UNITS	CIRCUIT	
Bias Voltage	V <sub>BIAS</sub>		2.5	-	6.0	V	①	
Input Voltage	V <sub>IN</sub>		0.5	-	3.0	V	①	
Output Voltage	V <sub>OUT(E)</sub> <sup>(*1)</sup>	I <sub>OUT</sub> =100mA						
			V <sub>OUT(T)</sub> <1.2V	-0.015	V <sub>OUT(T)</sub> <sup>(*2)</sup>	+0.015	V	①
			V <sub>OUT(T)</sub> ≥1.2V	-0.020		+0.020		
Maximum Output Current <sup>(*3)</sup>	I <sub>OUTMAX</sub>	V <sub>OUT(T)</sub> <1.2V, V <sub>BIAS</sub> =V <sub>CE</sub> =2.5V		1.0	-	-	A	①
		V <sub>OUT(T)</sub> ≥1.2V, V <sub>BIAS</sub> =V <sub>CE</sub> =V <sub>OUT(T)</sub> +1.3V						
Load Regulation	ΔV <sub>OUT</sub>	1mA≤I <sub>OUT</sub> ≤1A		-	37	68	mV	①
Dropout Voltage	V <sub>dif</sub> <sup>(*4)</sup>	I <sub>OUT</sub> =1A		-	E-1 <sup>(*5)</sup>		mV	①
Supply Current 1 <sup>(*6)</sup>	I <sub>BIAS</sub>	I <sub>OUT</sub> =0A		76	100	143	μA	②
Supply Current 2	I <sub>IN</sub>	I <sub>OUT</sub> =0A	V <sub>OUT(T)</sub> <1.2V	0.1	-	8.7	μA	②
			V <sub>OUT(T)</sub> ≥1.2V	3.9	-	14.2		
Stand-by Current 1	I <sub>BIAS_STB</sub>	V <sub>BIAS</sub> =6.0V, V <sub>IN</sub> =3.0V, V <sub>CE</sub> =V <sub>SS</sub>		-	0.01	0.10	μA	②
Stand-by Current 2	I <sub>IN_STB</sub>	V <sub>BIAS</sub> =6.0V, V <sub>IN</sub> =3.0V, V <sub>CE</sub> =V <sub>SS</sub>		-	0.01	0.15	μA	②
Bias Line Regulation	ΔV <sub>OUT</sub> / (ΔV <sub>BIAS</sub> ·V <sub>OUT</sub> )	V <sub>OUT(T)</sub> <1.2V, V <sub>CE</sub> =V <sub>BIAS</sub> , 2.5V≤V <sub>BIAS</sub> ≤6.0V		-	0.01	0.10	%V	①
		V <sub>OUT(T)</sub> ≥1.2V, V <sub>CE</sub> =V <sub>BIAS</sub> , V <sub>OUT(T)</sub> +1.3V≤V <sub>BIAS</sub> ≤6.0V						
Input Line Regulation	ΔV <sub>OUT</sub> / (ΔV <sub>IN</sub> ·V <sub>OUT</sub> )	V <sub>OUT(T)</sub> +0.1V≤V <sub>IN</sub> ≤3.0V		-	0.01	0.10	%V	①
Bias UVLO Voltage	V <sub>BIAS_UVL0D</sub>		V <sub>SS</sub>	-	1.28	V	①	
Bias UVLO Release Voltage	V <sub>BIAS_UVL0R</sub>		2.5	-	6.0	V	①	
Input UVLO Voltage	V <sub>IN_UVL0D</sub>		V <sub>SS</sub>	-	0.23	V	①	
Input UVLO Release Voltage	V <sub>IN_UVL0R</sub>		0.5	-	3.0	V	①	
Output Voltage Temperature Characteristics	ΔV <sub>OUT</sub> / (ΔT <sub>OP</sub> ·V <sub>OUT</sub> )	I <sub>OUT</sub> =100mA -40°C≤T <sub>OP</sub> ≤85°C		-	±30	-	ppm/°C	①
Bias Ripple Rejection Ratio	V <sub>BIAS_PSR</sub>	V <sub>BIAS</sub> =V <sub>CE</sub> =3.6V <sub>DC</sub> +0.2V <sub>p-PAC</sub> I <sub>OUT</sub> =100mA, f=1kHz, C <sub>BIAS</sub> =OPEN		-	60	-	dB	③
Input Ripple Rejection Ratio	V <sub>IN_PSR</sub>	V <sub>IN</sub> =V <sub>OUT(T)</sub> +0.3V <sub>DC</sub> +0.2V <sub>p-PAC</sub> I <sub>OUT</sub> =100mA, f=1kHz, C <sub>IN</sub> =OPEN		-	75	-	dB	③
Current Limit <sup>(*3)</sup>	I <sub>LIM</sub>	V <sub>OUT</sub> ={V <sub>OUT</sub> @I <sub>OUT</sub> =1A}×0.95		1.0	1.3	-	A	①
Short - Circuit Current	I <sub>SHORT</sub>	V <sub>OUT</sub> =V <sub>SS</sub>		-	90	-	mA	①
Thermal Shutdown Detect Temperature	T <sub>TSD</sub>	Junction Temperature		-	150	-	°C	①
Thermal Shutdown Release Temperature	T <sub>TSR</sub>	Junction Temperature		-	125	-	°C	①
Thermal Shutdown Hysteresis Width	T <sub>TSD</sub> -T <sub>TSR</sub>	Junction Temperature		-	25	-	°C	①
C <sub>L</sub> Auto-Discharge Resistance	R <sub>DCHG</sub>	V <sub>CE</sub> =V <sub>SS</sub> , V <sub>OUT</sub> =V <sub>OUT(T)</sub>		130	190	255	Ω	①
CE "H" Level Voltage	V <sub>CEH</sub>		0.65	-	6.00	V	④	
CE "L" Level Voltage	V <sub>CEL</sub>		V <sub>SS</sub>	-	0.41	V	④	
CE "H" Level Current	I <sub>CEH</sub>	V <sub>BIAS</sub> =V <sub>CE</sub> =6.0V		3.2	6.0	10.6	μA	④
CE "L" Level Current	I <sub>CEL</sub>	V <sub>BIAS</sub> =6.0V, V <sub>CE</sub> =V <sub>SS</sub>		-0.1	-	0.1	μA	④
SS Pin Current	I <sub>soft</sub>	SS Pin=V <sub>SS</sub>		3.60	5.00	6.55	μA	⑤
Soft-Start Threshold Voltage <sup>(*7)</sup>	V <sub>soft</sub>		(0.927)	(1.085)	(1.243)	V	-	

**NOTE:**

Unless otherwise stated, V<sub>BIAS</sub>=V<sub>CE</sub>=3.6V, V<sub>IN</sub>=V<sub>OUT(T)</sub>+0.3V, I<sub>OUT</sub>=1mA, C<sub>BIAS</sub>=C<sub>IN</sub>=1.0 μF, C<sub>L</sub>=2.2 μF, SS Pin=OPEN

(\*1) V<sub>OUT(E)</sub> = Effective output voltage

(\*2) V<sub>OUT(T)</sub> = Nominal output voltage

(\*3) Mount conditions affect heat dissipation. Maximum output current is not guaranteed when TSD starts to operate earlier.

(\*4) V<sub>dif</sub>={V<sub>IN1</sub>-V<sub>OUT1</sub>}

V<sub>IN1</sub> is an input voltage when V<sub>OUT1</sub> appears at the output during decreasing input voltage gradually.

V<sub>OUT1</sub> is a voltage equal to 98% of the output voltage where V<sub>BIAS</sub>=V<sub>CE</sub>=3.6 and V<sub>IN</sub>=V<sub>OUT(T)</sub>+0.3V at I<sub>OUT</sub>=1A is input to the V<sub>IN</sub> pin.

(\*5) Please refer to the table E-1 named DROPOUT VOLTAGE CHART

(\*6) Supply current 1 (I<sub>BIAS</sub>) may be fluctuated because that some bias current flows into the output.

(\*7) Design value

## ■ ELECTRICAL CHARACTERISTICS (Continued)

### ● Dropout Voltage Chart

NOMINAL OUTPUT VOLTAGE  $V_{OUT(T)}$	E-1														
	DROPOUT VOLTAGE (mV)														
	$V_{BIAS}=3.0V$			$V_{BIAS}=3.3V$			$V_{BIAS}=3.6V$			$V_{BIAS}=4.2V$			$V_{BIAS}=5.0V$		
	$V_{GS}$	Vdif(mV)		$V_{GS}$	Vdif(mV)		$V_{GS}$	Vdif(mV)		$V_{GS}$	Vdif(mV)		$V_{GS}$	Vdif(mV)	
(V)	TYP.	MAX.	(V)	TYP.	MAX.	(V)	TYP.	MAX.	(V)	TYP.	MAX.	(V)	TYP.	MAX.	
0.5	2.5	152	218	2.8	146	213	3.1	146	213	3.7	140	208	4.5	137	206
0.6	2.4	155	223	2.7			3.0			3.6			4.4		
0.7	2.3			2.6	2.9	3.5	4.3								
0.8	2.2	158	228	2.5	152	218	2.8			3.4			4.2		
0.9	2.1	162	233	2.4	155	223	2.7			3.3			4.1		
1.0	2.0	165	238	2.3			2.6	3.2	4.0						
1.1	1.9	167	243	2.2	158	228	2.5	152	218	3.1	146	213	3.9	140	208
1.2	1.8	169	253	2.1	162	233	2.4	3.0	3.8						
1.3	1.7	179	268	2.0	165	238	2.3	2.9	3.7						
1.4	1.6	189	283	1.9	167	243	2.2	158	228	2.8			3.6		
1.5	1.5	202	303	1.8	169	253	2.1	162	233	2.7			3.5		
1.6	1.4	213	328	1.7	179	268	2.0	165	238	2.6	3.4				
1.7	1.3	225	373	1.6	189	283	1.9	167	243	2.5	152	218	3.3	146	213
1.8	1.2	255	423	1.5	202	303	1.8	169	253	2.4	155	223	3.2		

\* Dropout voltage is defined as the  $V_{GS}(=V_{BIAS}-V_{OUT(E)})$  of the driver transistor.

■ TEST CIRCUITS

CIRCUIT①

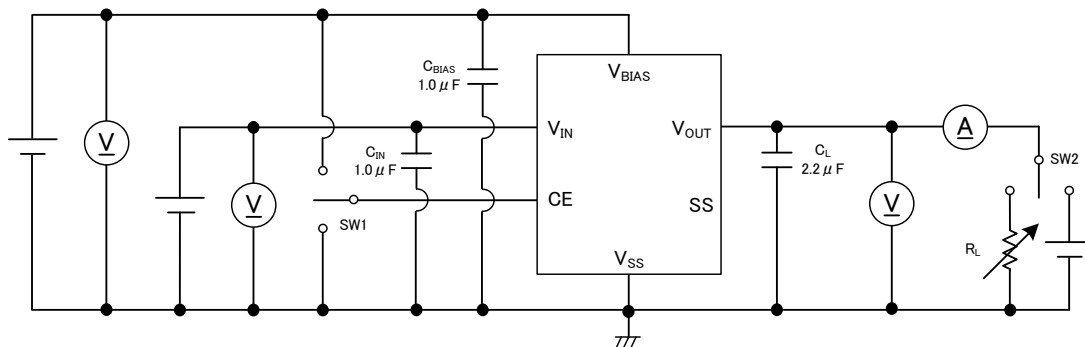

CIRCUIT②

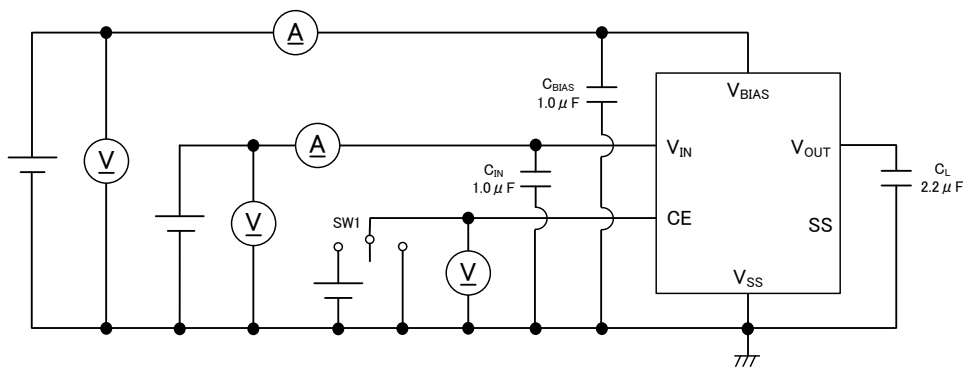

CIRCUIT③

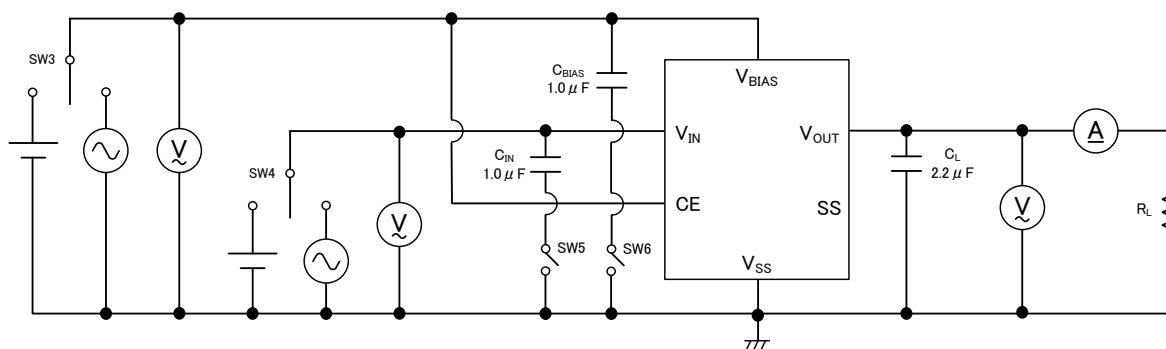

■ **TEST CIRCUITS (Continued)**

CIRCUIT④

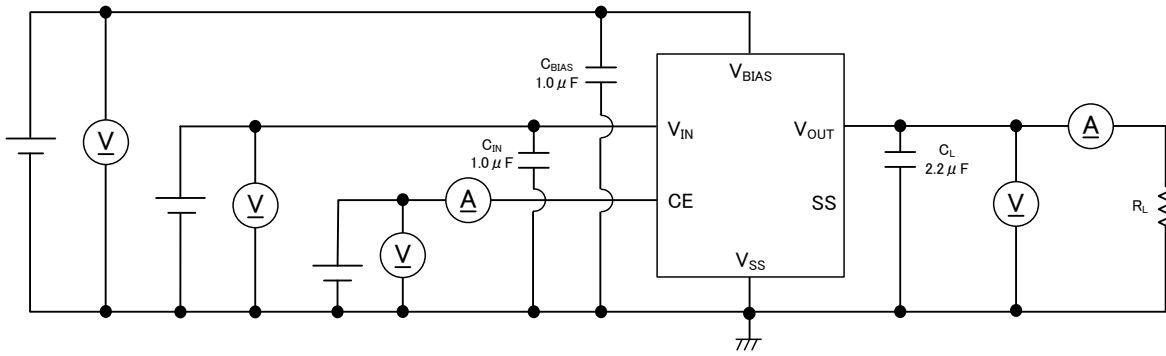

CIRCUIT⑤

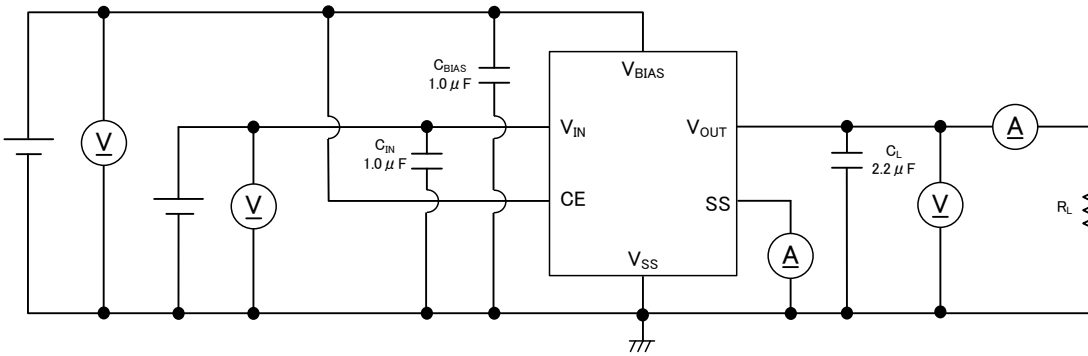

## ■ OPERATIONAL DESCRIPTION

The voltage divided by resistors R1 and R2 is compared with the internal reference voltage by the error amplifier. The  $V_{OUT}$  pin is then driven by the subsequent output signal. The output voltage at the  $V_{OUT}$  pin is controlled and stabilized by a system of negative feedback.

$V_{BIAS}$  pin is power supply pin for output voltage control circuit, protection circuit and CE circuit. Also, the  $V_{BIAS}$  pin supplies some current as output current.  $V_{IN}$  pin is connected to a driver transistor and provides output current.

In order to obtain high efficient output current through low on-resistance, please take enough  $V_{GS} (=V_{BIAS} - V_{OUT(E)})$  of the driver transistor.

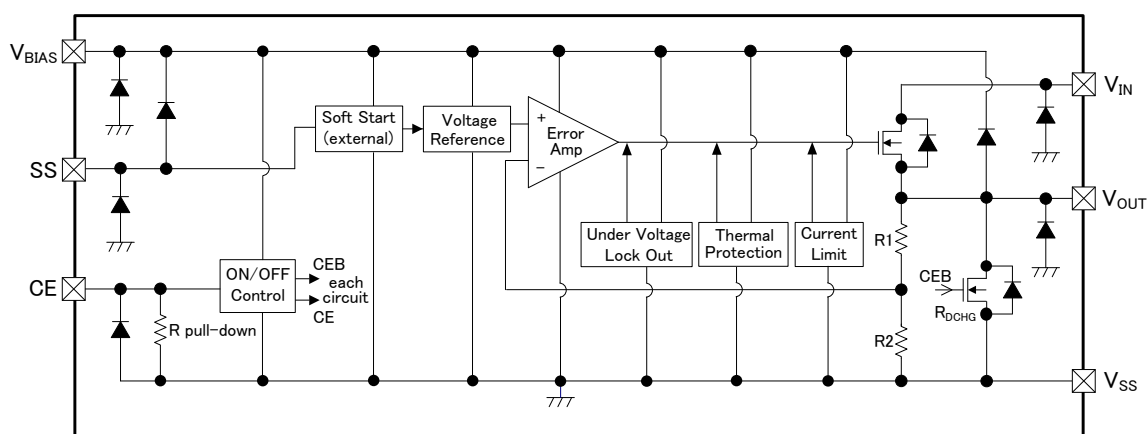

Figure1: XC6603 Series, Type A

### <Soft-Start Function>

With the XC6603 (Type A), the inrush current ( $I_{RUSH}$ ) from  $V_{IN}$  to  $V_{OUT}$  for charging  $C_L$  at start-up can be reduced and makes the  $V_{IN}$  stable.

With connecting a soft-start capacitor to the SS pin, rise time of the reference voltage ( $V_{ref}$ ) is adjusted, then soft-start time can be set freely. The inrush current conflicts with the soft-start time, so that the inrush current is decreased if the soft-start time is set longer.

Please also note that the inrush current is depended on  $C_L$  or  $V_{BIAS}$ . When  $C_L$  or  $V_{BIAS}$  is larger, the inrush current becomes larger. Please set an appropriate soft-start time under the conditions of use.

When the SS pin is left open, soft-start circuit will not operate.

Soft-start time is calculated by the following formulas.

$$t_{SS} = C_{SS} \times V_{soft} / I_{soft}$$

$t_{SS}$ : Soft-start time

$C_{SS}$ : Soft-start capacitance

$V_{soft}$ : Soft-start threshold voltage

$I_{soft}$ : SS pin current

Figure2: XC6603 Series,  $C_{SS}$  Range of use

SOFT-START CAPACITOR	SOFT-START TIME
$C_{SS}$	$t_{SS}$ (TYP.)
~0.01 $\mu$ F	~2.17ms

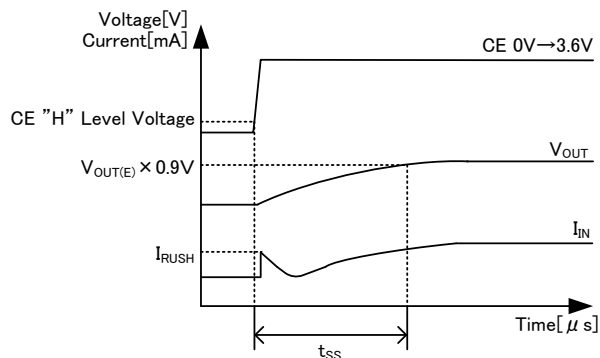

## ■ OPERATIONAL DESCRIPTION (Continued)

### <Current Limiter, Short-Circuit Protection>

The XC6603 series includes a combination of a fixed current limiter circuit and a foldback short-circuit protection. When the output current reaches the current limit, the output voltage drops and this operation makes the output current foldback to be decreased.

### <Thermal Shutdown Circuit (TSD) >

When the junction temperature of the built-in driver transistor reaches the temperature limit, the thermal shutdown circuit operates and the driver transistor will be set to OFF. The IC resumes its operation when the thermal shutdown function is released and the IC's operation is automatically restored because the junction temperature drops to the level of the thermal shutdown release temperature.

### <Under Voltage Lock Out (UVLO) >

When the  $V_{BIAS}$  pin and  $V_{IN}$  pin voltage drops, the output driver transistor is set to OFF by UVLO function to prevent false output caused by unstable operation of the internal circuitry. When the  $V_{BIAS}$  pin voltage and the  $V_{IN}$  pin voltage rises at release voltage, the UVLO function is released. The driver transistor is turned ON and start to operate voltage regulation.

### <CE Pin>

The XC6603 internal circuitry can be shutdown via the signal to the CE pin. In shutdown mode with CE low level voltage, the  $V_{OUT}$  pin will be pulled down to the  $V_{SS}$  level via  $C_L$  discharge resistance ( $R_{DCHG}$ ) placed in parallel to R1 and R2.

The CE pin has pull-down circuitry so that CE input current flows during IC operation. If the CE pin voltage is taken from  $V_{BIAS}$  pin or  $V_{SS}$  pin then logic is fixed and the IC will operate normally. However, supply current may increase as a result of through current in the IC's internal circuitry when medium voltage is input.

### < $C_L$ High Speed Auto-Discharge>

XC6603 series can quickly discharge the electric charge at the output capacitor ( $C_L$ ) via the internal transistor located between the  $V_{OUT}$  pin and the  $V_{SS}$  pin when a low signal to the CE pin which enables a whole IC circuit put into OFF state. When the IC is disabled, electric charge at the output capacitor ( $C_L$ ) is quickly discharged so that it could avoid malfunction. Discharge time of the output capacitor ( $C_L$ ) is set by the  $C_L$  auto-discharge resistance ( $R_{DCHG}$ ) and the output capacitor ( $C_L$ ). By setting time constant of a  $C_L$  auto-discharge resistance value ( $R_{DCHG}$ ) and an output capacitor value ( $C_L$ ) as  $\tau$  ( $\tau = C_L \times R_{DCHG}$ ), the output voltage after discharge via the internal transistor is calculated by the following formula. Please also note  $R_{DCHG}$  is depended on  $V_{BIAS}$ . When  $V_{BIAS}$  is larger,  $R_{DCHG}$  is smaller.

$$V = V_{OUT(E)} \times e^{-t/\tau} \text{ or } t = \tau \ln (V_{OUT(E)} / V)$$

V: Output voltage during discharge

$V_{OUT(E)}$ : Initial Output voltage

t: Discharge time

$\tau$ :  $C_L \times R_{DCHG}$

### <Low ESR Capacitor>

With the XC6603 series, a stable output voltage is achievable even if used with low ESR capacitors, as a phase compensation circuit is built-in. The output capacitor ( $C_L$ ) should be connected as close to  $V_{OUT}$  pin and  $V_{SS}$  pin to obtain stable phase compensation. Values required for the phase compensation are as the table below.

For a stable power input, please connect a bias capacitor ( $C_{BIAS}$ ) between the  $V_{BIAS}$  pin and the  $V_{SS}$  pin. Also, please connect an input capacitor ( $C_{IN}$ ) between the  $V_{IN}$  pin and the  $V_{SS}$  pin. In order to ensure the stable phase compensation while avoiding run-out of values, please use the capacitor ( $C_{BIAS}$ ,  $C_{IN}$  and  $C_L$ ) which does not depend on bias or temperature too much. The table below (Figure 3) shows recommended values of  $C_{BIAS}$ ,  $C_{IN}$  and  $C_L$ .

Figure 3: Recommended Values of  $C_{BIAS}$ ,  $C_{IN}$  and  $C_L$  (MIN.)

OUTPUT VOLTAGE RANGE	BIAS CAPACITOR	INPUT CAPACITOR	OUTPUT CAPACITOR
$V_{OUT(T)}$	$C_{BIAS}$	$C_{IN}$	$C_L$
0.5V~1.8V	1.0 $\mu$ F	1.0 $\mu$ F	2.2 $\mu$ F

## ■NOTES ON USE

1. For temporary, transitional voltage drop or voltage rising phenomenon, the IC is liable to malfunction should the ratings be exceeded.
2. Where wiring impedance is high, operations may become unstable due to noise and/or phase lag depending on output current. Please keep the resistance low for the  $V_{BIAS}$ ,  $V_{IN}$  and  $V_{SS}$  wiring in particular.
3. Please wire the  $C_{BIAS}$ ,  $C_{IN}$  and  $C_L$  as close to the IC as possible.
4. Capacitances of these capacitors ( $C_{BIAS}$ ,  $C_{IN}$ ,  $C_L$ ) are decreased by the influences of bias voltage and ambient temperature. Care shall be taken for capacitor selection to ensure stability of phase compensation from the point of ESR influence.
5. When it is used in a quite small input / output dropout voltage, output may go into unstable operation. Please test it thoroughly before using it in production.
6. Torex places an importance on improving our products and their reliability.  
We request that users incorporate fail-safe designs and post-aging protection treatment when using Torex products in their systems.

## TYPICAL PERFORMANCE CHARACTERISTICS

\* Unless otherwise stated,  $V_{BIAS}=V_{CE}=3.6V$ ,  $V_{IN}=V_{OUT(T)}+0.3V$ ,  $I_{OUT}=1mA$ , SS Pin=OPEN,  $C_{BIAS}=C_{IN}=1.0\mu F$ ,  $C_L=2.2\mu F$ ,  $T_a=25^\circ C$

(1) Output Voltage vs. Output Current

XC6603A051MR-G

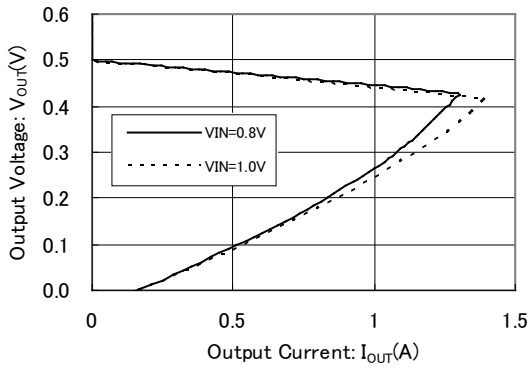

(2) Output Voltage vs. Bias Voltage

XC6603A051xR-G

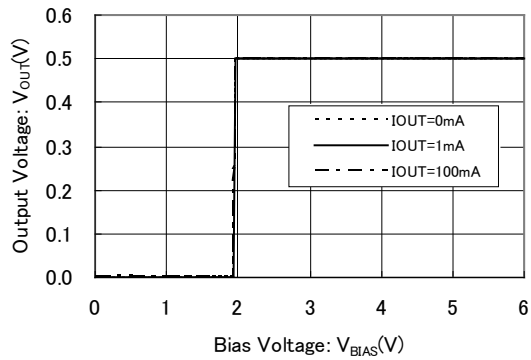

XC6603A121MR-G

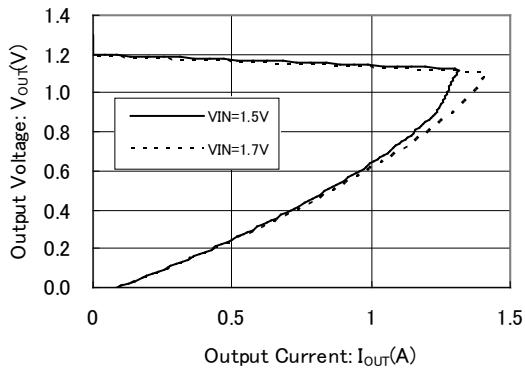

XC6603A121xR-G

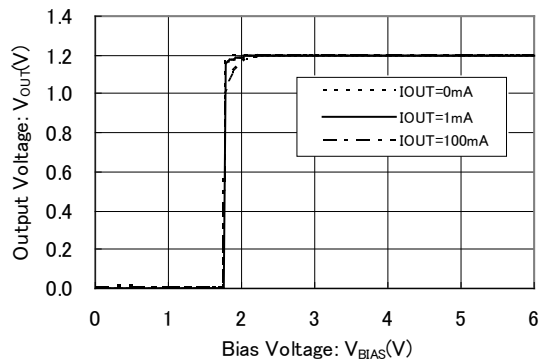

XC6603A181MR-G

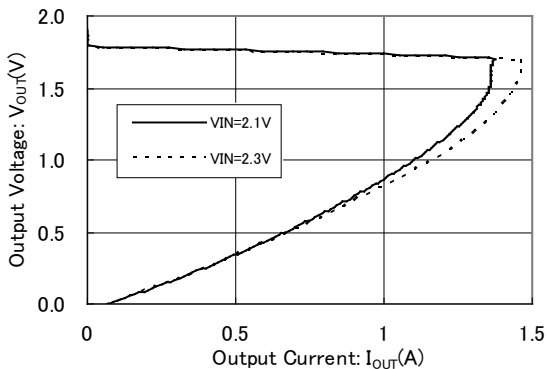

XC6603A181xR-G

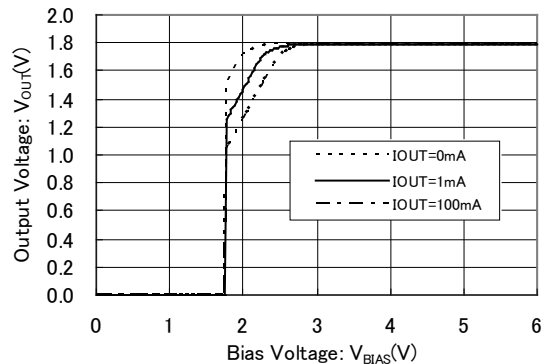

\* Mount conditions affect heat dissipation. Thermal shutdown may start to operate before reaching the current limit.

## TYPICAL PERFORMANCE CHARACTERISTICS (Continued)

\* Unless otherwise stated,  $V_{BIAS}=V_{CE}=3.6V$ ,  $V_{IN}=V_{OUT(T)}+0.3V$ ,  $I_{OUT}=1mA$ , SS Pin=OPEN,  $C_{BIAS}=C_{IN}=1.0\mu F$ ,  $C_L=2.2\mu F$ ,  $T_a=25^\circ C$

(3) Output Voltage vs. Input Voltage

XC6603A051xR-G

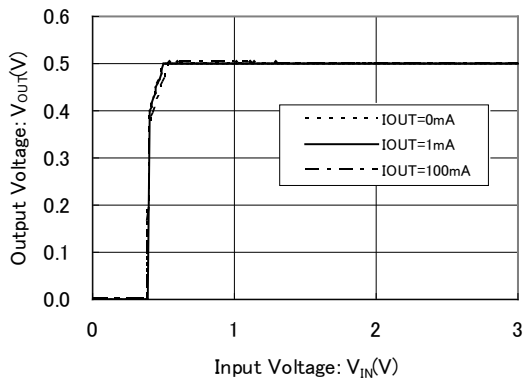

XC6603A121xR-G

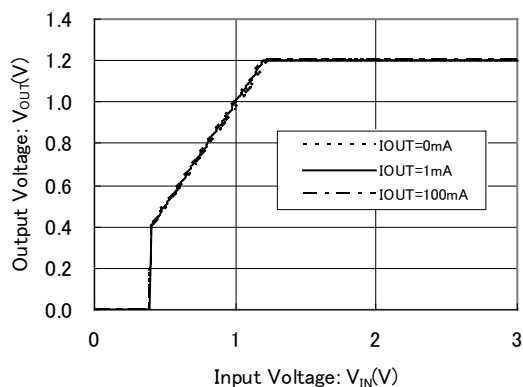

XC6603A181xR-G

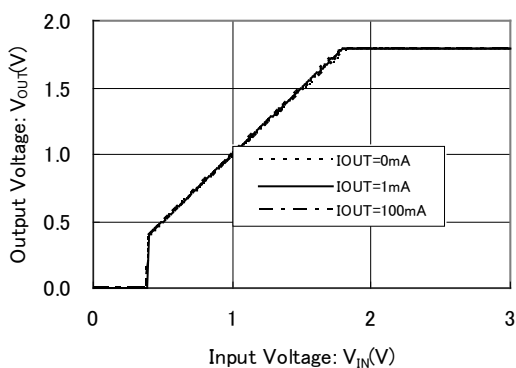

(4) Dropout Voltage vs. Output Current

XC6603A121MR-G

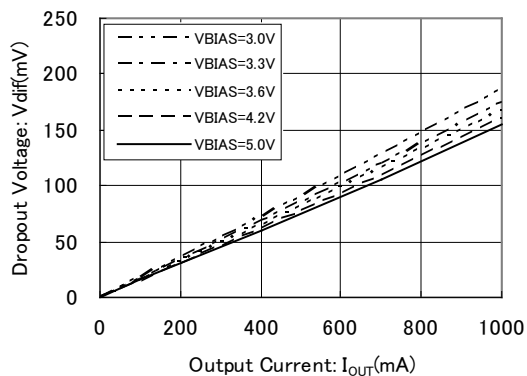

XC6603Axx1MR-G

$I_{OUT}=1A$

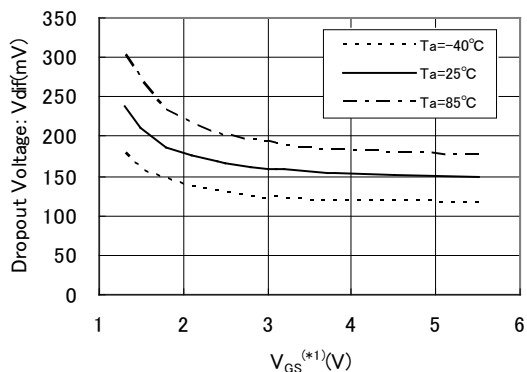

(\*)  $V_{GS}$  is a Gate-Source voltage of the driver transistor that is defined as the value of  $V_{BIAS} - V_{OUT(E)}$ .

A value of the dropout voltage is determined by the value of the  $V_{GS}$ .

## TYPICAL PERFORMANCE CHARACTERISTICS (Continued)

\* Unless otherwise stated,  $V_{BIAS}=V_{CE}=3.6V$ ,  $V_{IN}=V_{OUT(T)}+0.3V$ ,  $I_{OUT}=1mA$ , SS Pin=OPEN,  $C_{BIAS}=C_{IN}=1.0\mu F$ ,  $C_L=2.2\mu F$ ,  $T_a=25^\circ C$

(5) Supply Bias Current vs. Bias Voltage

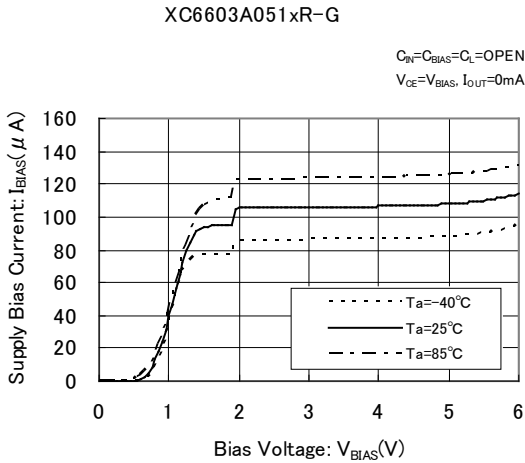

(6) Supply Input Current vs. Input Voltage

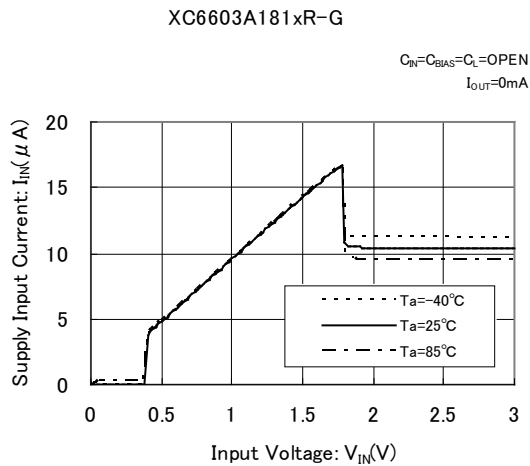
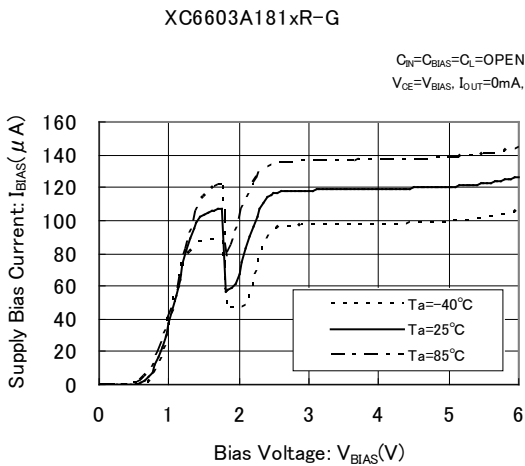
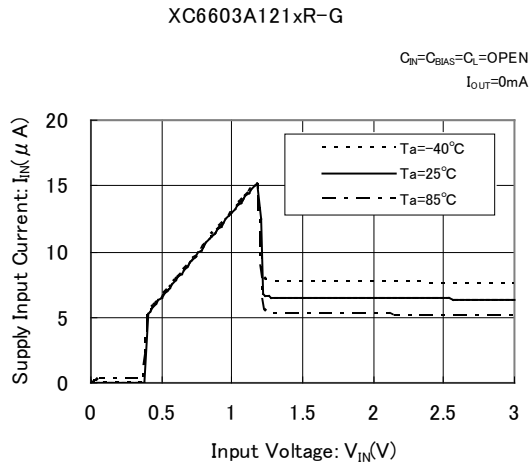
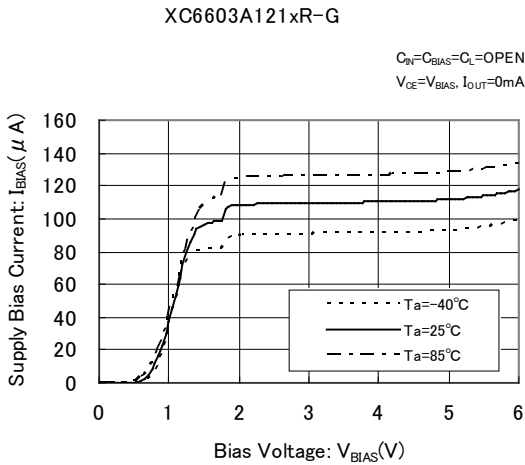
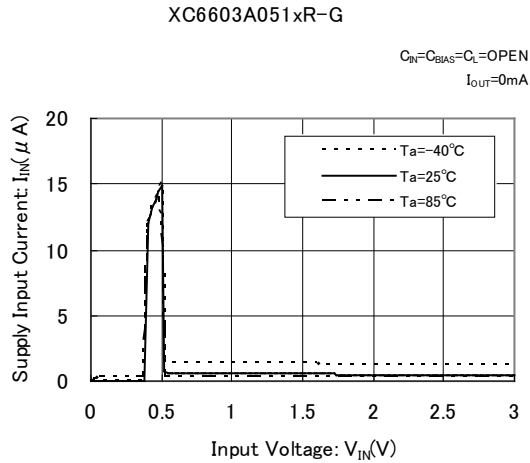

## ■ TYPICAL PERFORMANCE CHARACTERISTICS (Continued)

\* Unless otherwise stated,  $V_{BIAS}=V_{CE}=3.6V$ ,  $V_{IN}=V_{OUT(T)}+0.3V$ ,  $I_{OUT}=1mA$ , SS Pin=OPEN,  $C_{BIAS}=C_{IN}=1.0\mu F$ ,  $C_L=2.2\mu F$ ,  $T_a=25^\circ C$

(7) Output Voltage vs. Ambient Temperature

XC6603A051xR-G

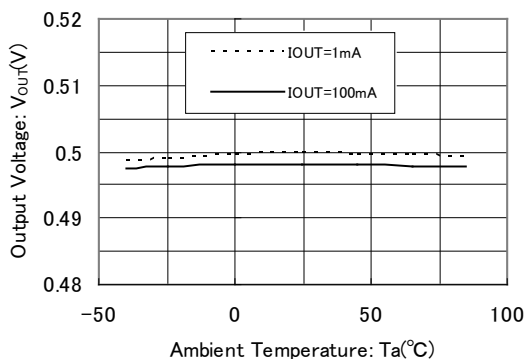

(8) Supply Bias Current vs. Ambient Temperature

XC6603A051xR-G

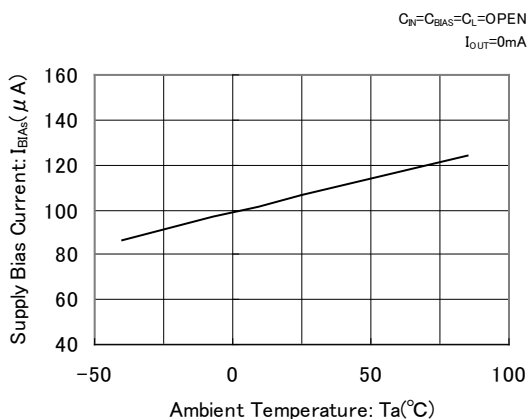

XC6603A121xR-G

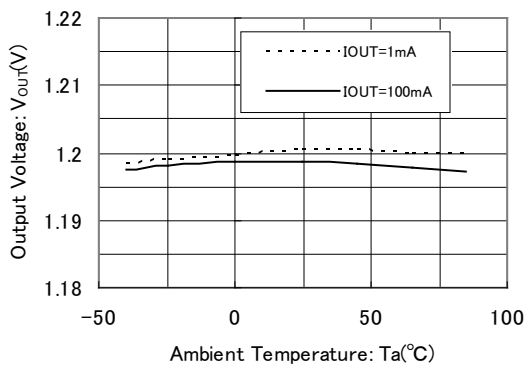

XC6603A121xR-G

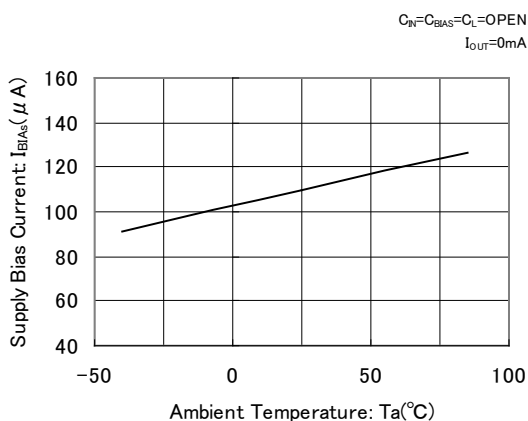

XC6603A181xR-G

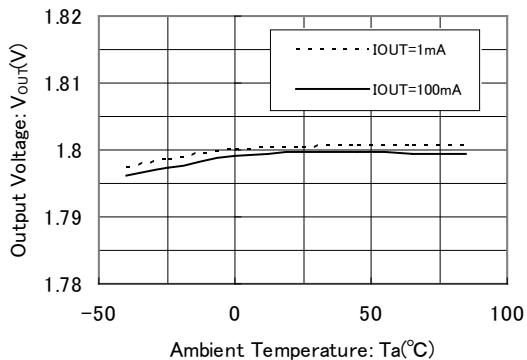

XC6603A181xR-G

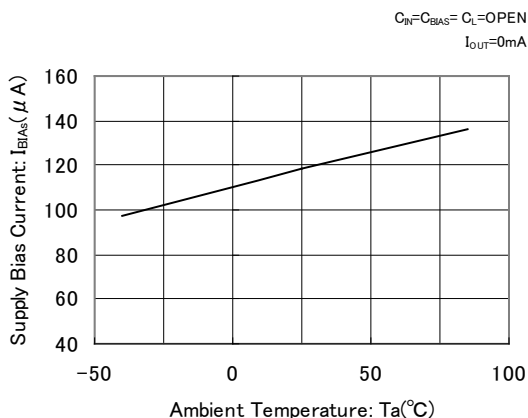

## TYPICAL PERFORMANCE CHARACTERISTICS (Continued)

\* Unless otherwise stated,  $V_{BIAS}=V_{CE}=3.6V$ ,  $V_{IN}=V_{OUT(T)}+0.3V$ ,  $I_{OUT}=1mA$ , SS Pin=OPEN,  $C_{BIAS}=C_{IN}=1.0\mu F$ ,  $C_L=2.2\mu F$ ,  $T_a=25^\circ C$

### (9) Supply Input Current vs. Ambient Temperature

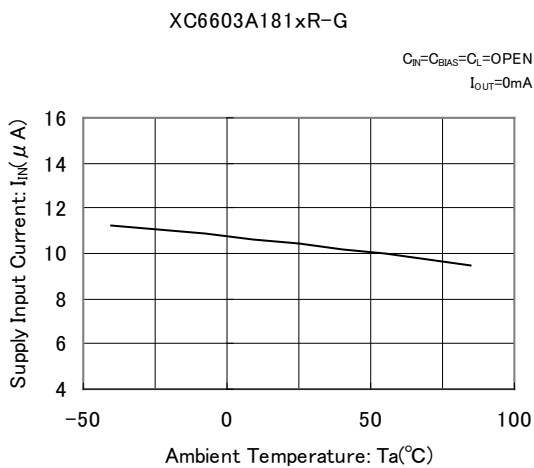
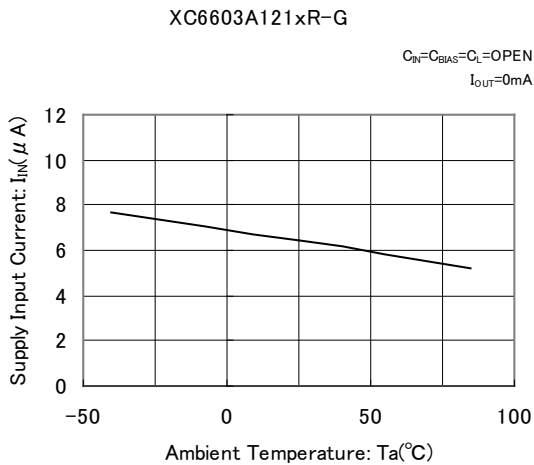
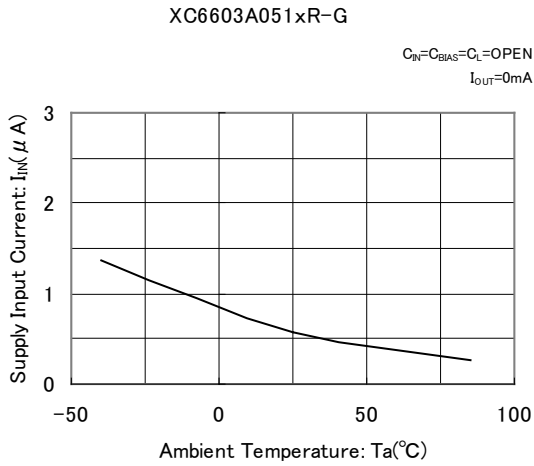

## ■ TYPICAL PERFORMANCE CHARACTERISTICS (Continued)

\* Unless otherwise stated,  $V_{BIAS}=V_{CE}=3.6V$ ,  $V_{IN}=V_{OUT(T)}+0.3V$ ,  $I_{OUT}=1mA$ , SS Pin=OPEN,  $C_{BIAS}=C_{IN}=1.0\mu F$ ,  $C_L=2.2\mu F$ ,  $T_a=25^\circ C$

(10) Bias Transient Response

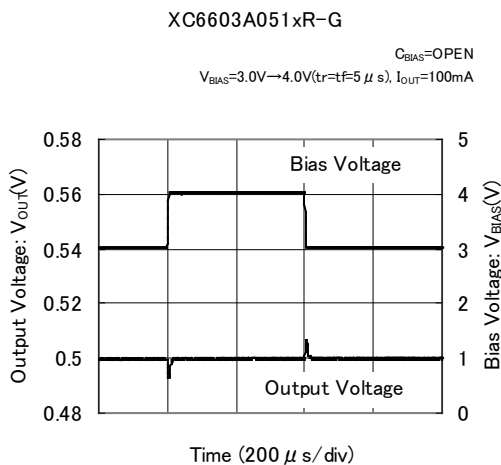

(11) Input Transient Response

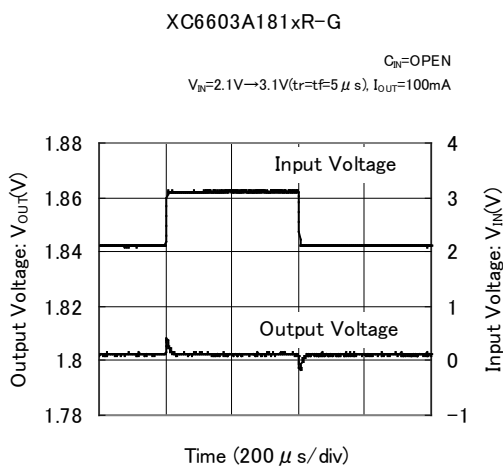
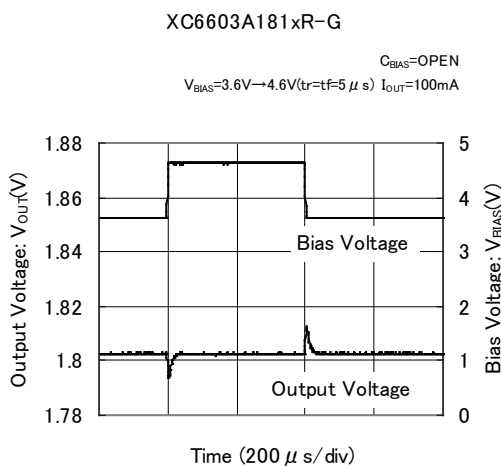
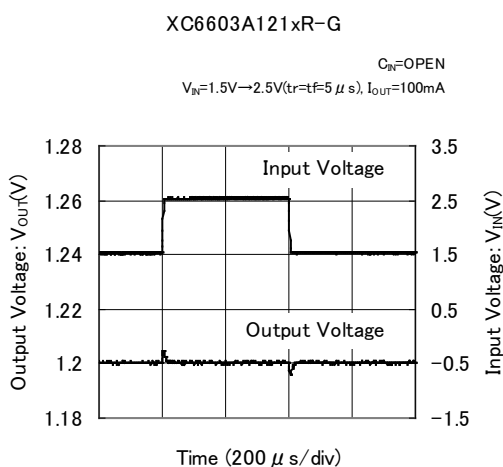
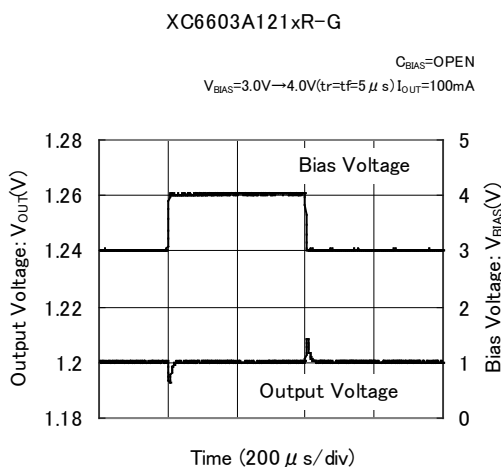
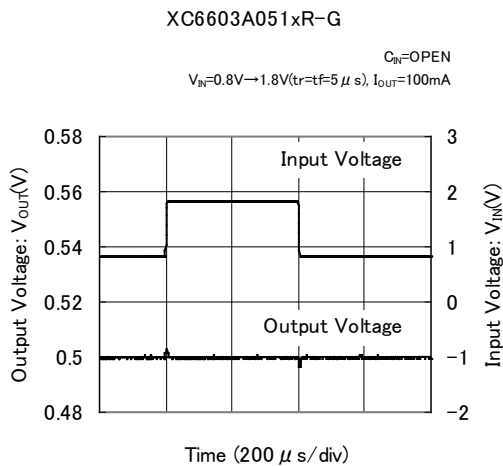

## TYPICAL PERFORMANCE CHARACTERISTICS (Continued)

\* Unless otherwise stated,  $V_{BIAS}=V_{CE}=3.6V$ ,  $V_{IN}=V_{OUT(T)}+0.3V$ ,  $I_{OUT}=1mA$ , SS Pin=OPEN,  $C_{BIAS}=C_{IN}=1.0\mu F$ ,  $C_L=2.2\mu F$ ,  $T_a=25^\circ C$

### (12) Load Transient Response

XC6603A051xR-G

$I_{OUT}=1mA \leftrightarrow 100mA (tr=tf=5\mu s)$

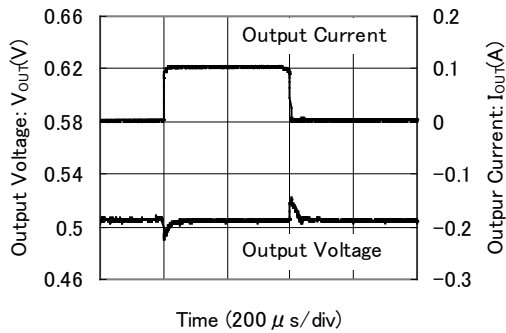

XC6603A121xR-G

$I_{OUT}=1mA \leftrightarrow 100mA (tr=tf=5\mu s)$

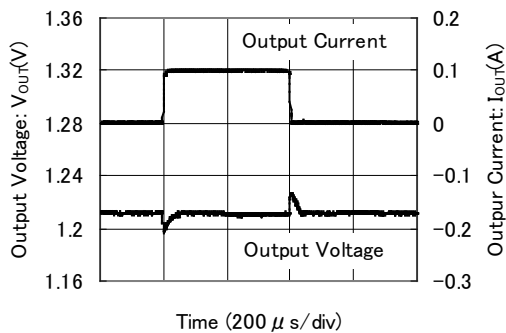

XC6603A181xR-G

$I_{OUT}=1mA \leftrightarrow 100mA (tr=tf=5\mu s)$

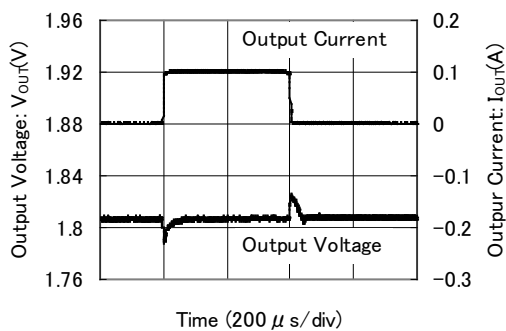

## TYPICAL PERFORMANCE CHARACTERISTICS (Continued)

\* Unless otherwise stated,  $V_{BIAS}=V_{CE}=3.6V$ ,  $V_{IN}=V_{OUT(T)}+0.3V$ ,  $I_{OUT}=1mA$ , SS Pin=OPEN,  $C_{BIAS}=C_{IN}=1.0\mu F$ ,  $C_L=2.2\mu F$ ,  $T_a=25^\circ C$

### (13) CE Input Response

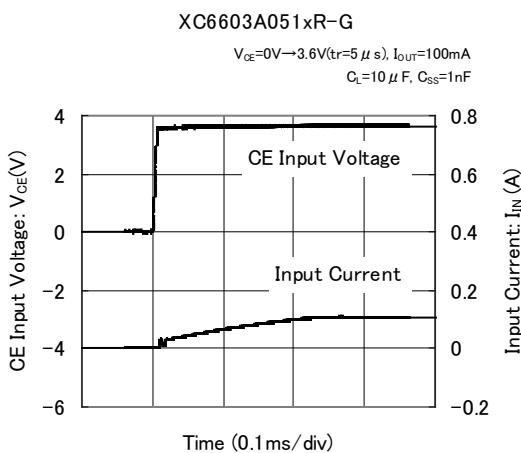
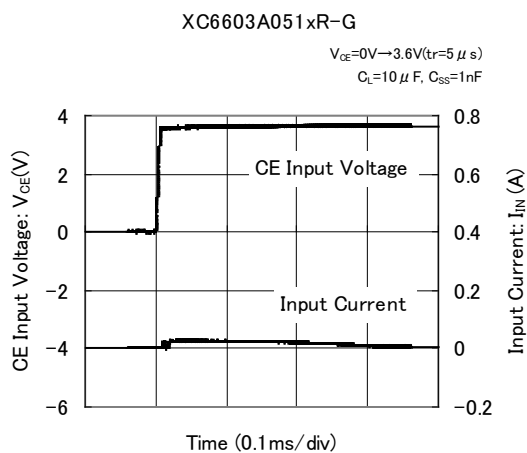
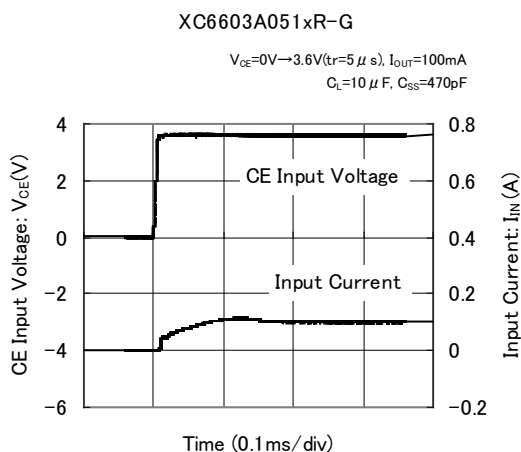
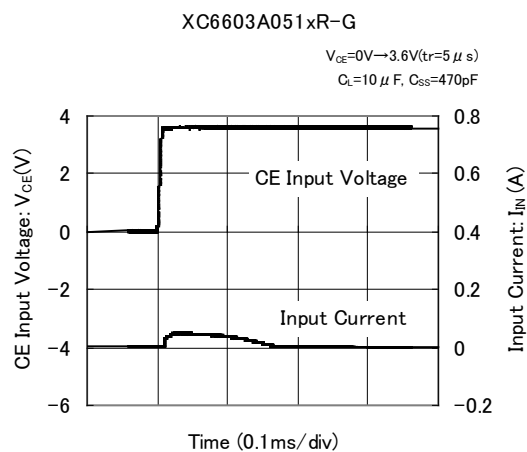
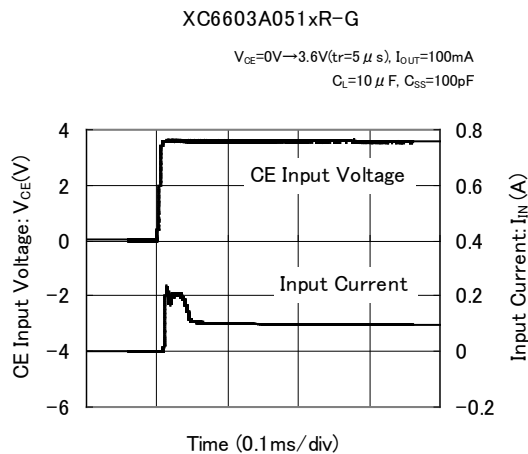
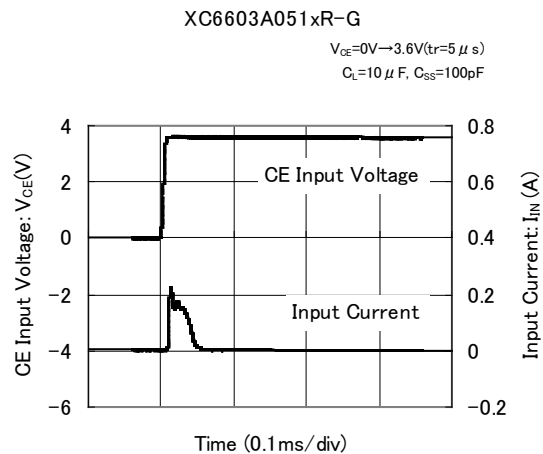

## TYPICAL PERFORMANCE CHARACTERISTICS (Continued)

\* Unless otherwise stated,  $V_{BIAS}=V_{CE}=3.6V$ ,  $V_{IN}=V_{OUT(T)}+0.3V$ ,  $I_{OUT}=1mA$ , SS Pin=OPEN,  $C_{BIAS}=C_{IN}=1.0\mu F$ ,  $C_L=2.2\mu F$ ,  $T_a=25^\circ C$

### (13) CE Input Response (Continued)

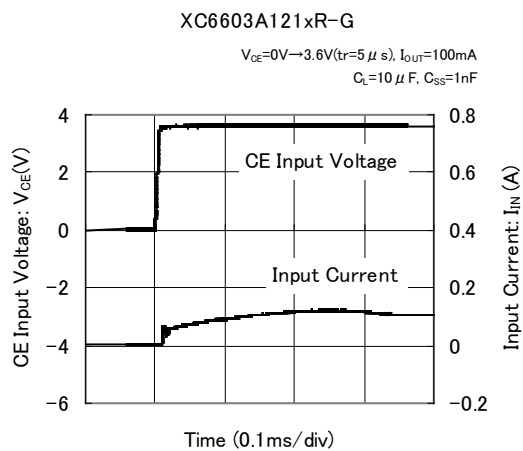
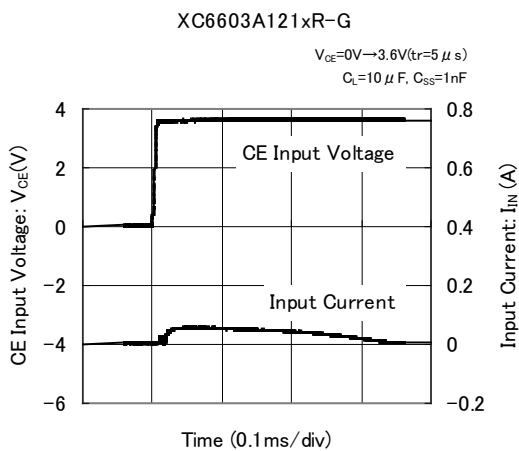
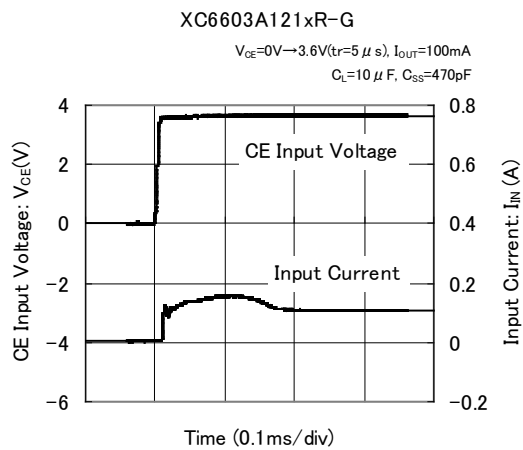
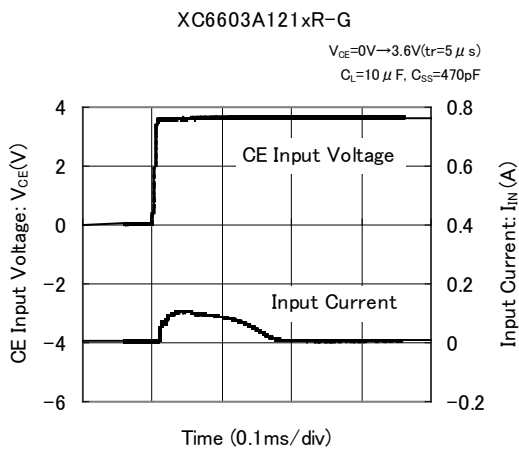
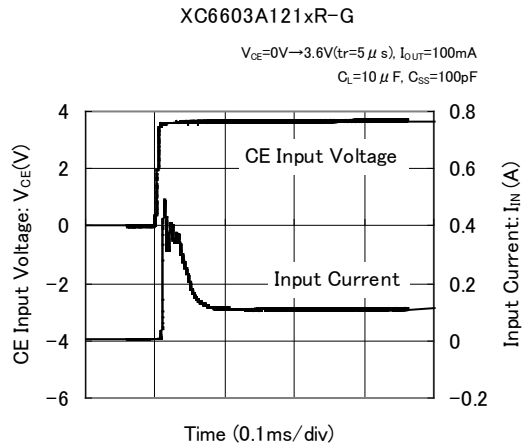
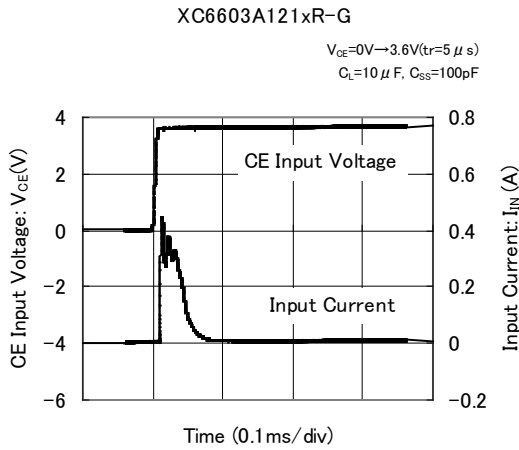

## ■ TYPICAL PERFORMANCE CHARACTERISTICS (Continued)

\* Unless otherwise stated,  $V_{BIAS}=V_{CE}=3.6V$ ,  $V_{IN}=V_{OUT(T)}+0.3V$ ,  $I_{OUT}=1mA$ , SS Pin=OPEN,  $C_{BIAS}=C_{IN}=1.0\mu F$ ,  $C_L=2.2\mu F$ ,  $T_a=25^\circ C$

### (13) CE Input Response (Continued)

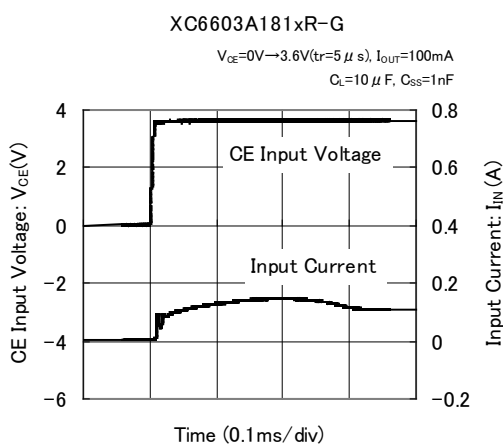
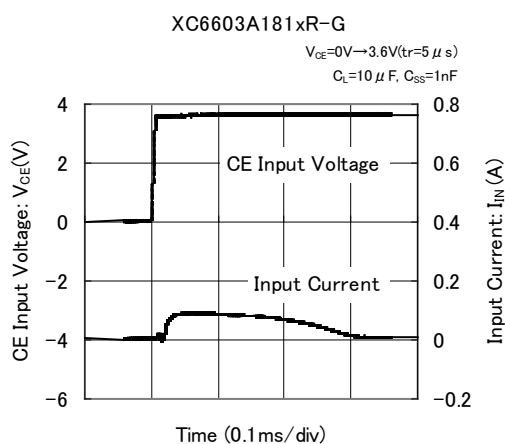
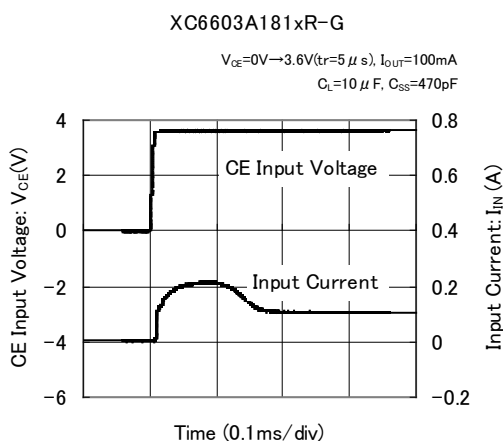
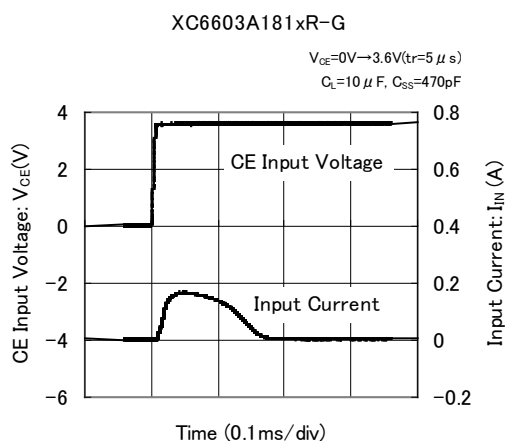
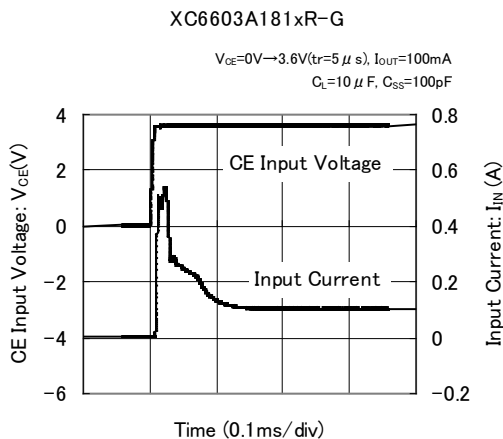
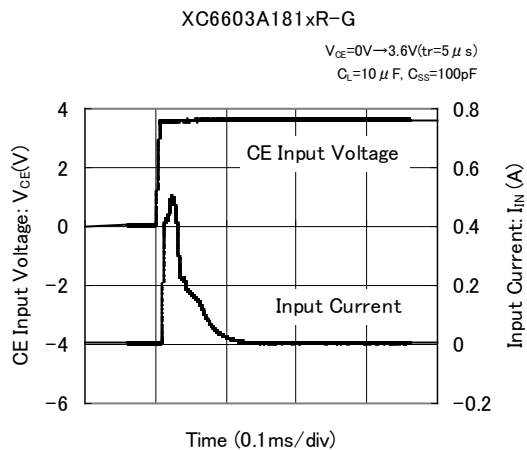

## TYPICAL PERFORMANCE CHARACTERISTICS (Continued)

\* Unless otherwise stated,  $V_{BIAS}=V_{CE}=3.6V$ ,  $V_{IN}=V_{OUT(T)}+0.3V$ ,  $I_{OUT}=1mA$ , SS Pin=OPEN,  $C_{BIAS}=C_{IN}=1.0\mu F$ ,  $C_L=2.2\mu F$ ,  $T_a=25^\circ C$

(14) CE Rising Response Time

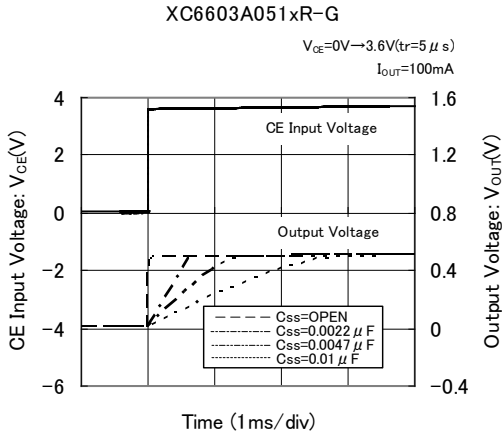

(15) Adjustable Soft-start Time

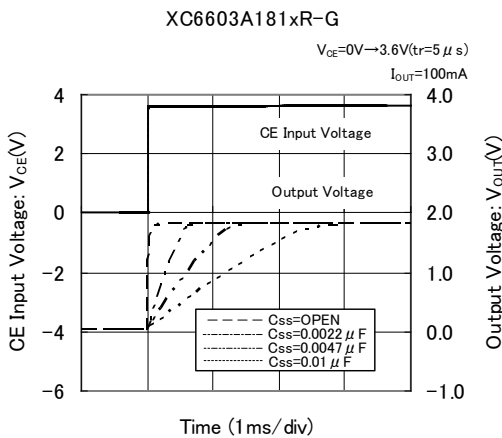
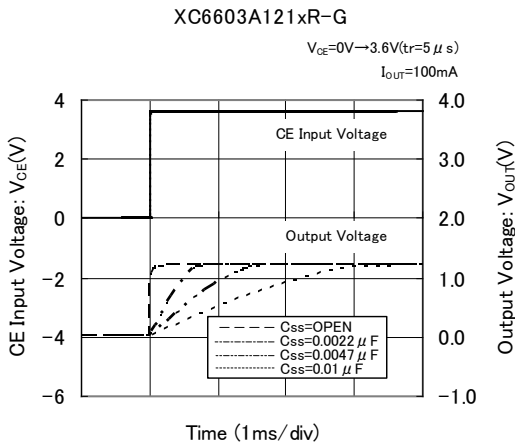
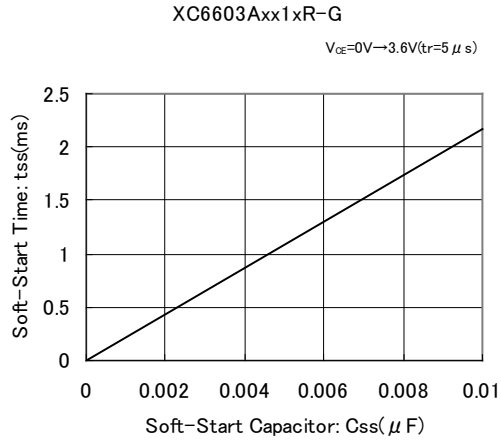

## ■ TYPICAL PERFORMANCE CHARACTERISTICS (Continued)

\* Unless otherwise stated,  $V_{BIAS}=V_{CE}=3.6V$ ,  $V_{IN}=V_{OUT(T)}+0.3V$ ,  $I_{OUT}=1mA$ , SS Pin=OPEN,  $C_{BIAS}=C_{IN}=1.0\mu F$ ,  $C_L=2.2\mu F$ ,  $T_a=25^\circ C$

(16) Bias Voltage Ripple Rejection Rate

XC6603A051xR-G

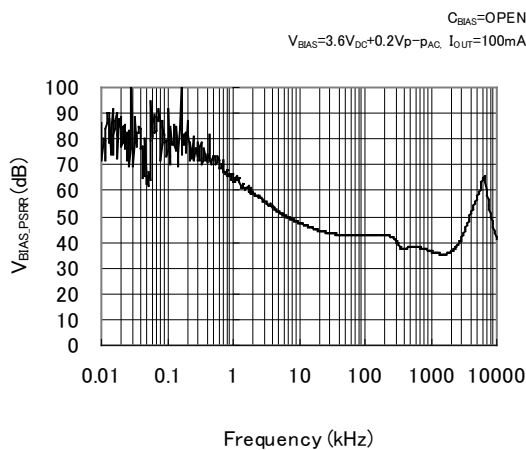

(17) Input Voltage Ripple Rejection Rate

XC6603A051xR-G

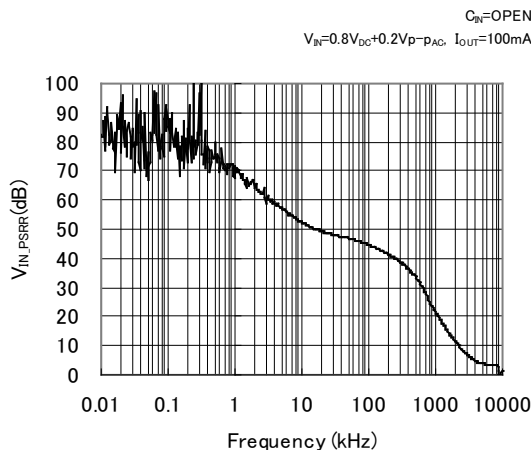

XC6603A121xR-G

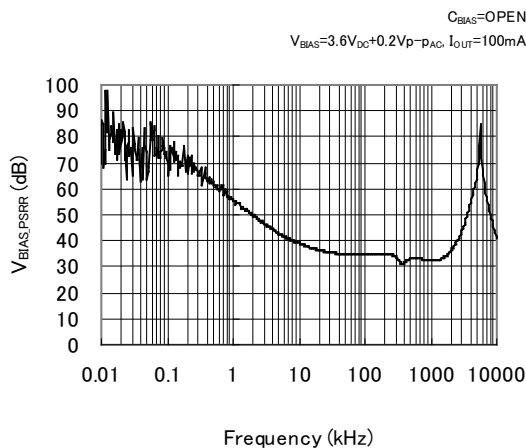

XC6603A121xR-G

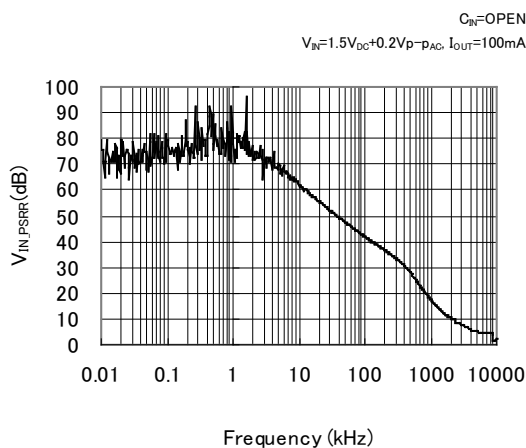

XC6603A181xR-G

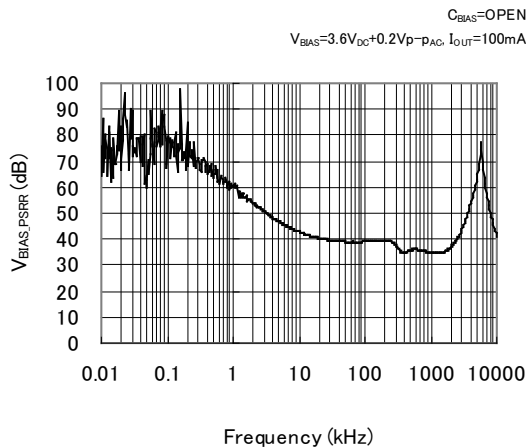

XC6603A181xR-G

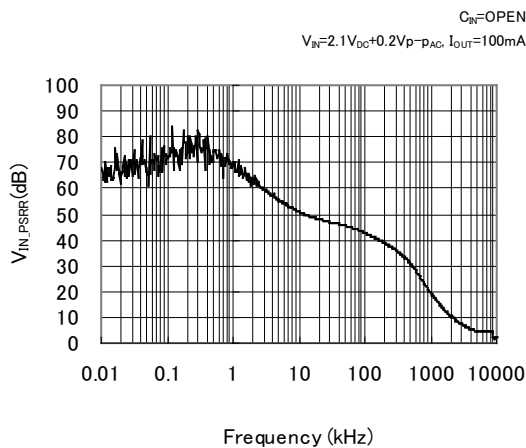

## ■ PACKAGING INFORMATION

For the latest package information go to, [www.torexsemi.com/technical-support/packages](http://www.torexsemi.com/technical-support/packages)

PACKAGE	OUTLINE / LAND PATTERN	THERMAL CHARACTERISTICS
SOT-26W	<a href="#">SOT-26W PKG</a>	<a href="#">SOT-26W Power Dissipation</a>
USP-6C	<a href="#">USP-6C PKG</a>	<a href="#">USP-6C Power Dissipation</a>

## MARKING RULE

① represents product series

MARK	PRODUCT SERIES
S	XC6603A****-G

SOT-26W

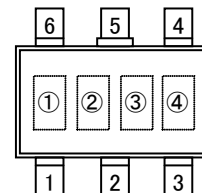

② represents output voltage

MARK	OUTPUT VOLTAGE (V)	MARK	OUTPUT VOLTAGE (V)
A	0.5	K	1.2
B	0.6	L	1.3
C	0.7	M	1.4
D	0.8	N	1.5
E	0.9	P	1.6
F	1.0	R	1.7
H	1.1	S	1.8

③④ represents production lot number  
01 to 09, 0A to 0Z, 11 to 9Z, A1 to A9, AA to Z9, B1 to ZZ in order.  
(G, I, J, O, Q, W excluded)

\*No character inversion used.

## ■ MARKING RULE (Continued)

① represents product series

MARK	PRODUCT SERIES
S	XC6603*****-G

② represents regulator type

MARK	PRODUCT SERIES
A	XC6603A*****-G

③ represents output voltage

MARK	OUTPUT VOLTAGE (V)	MARK	OUTPUT VOLTAGE (V)
A	0.5	K	1.2
B	0.6	L	1.3
C	0.7	M	1.4
D	0.8	N	1.5
E	0.9	P	1.6
F	1.0	R	1.7
H	1.1	S	1.8

④⑤ represents production lot number

01 to 09, 0A to 0Z, 11 to 9Z, A1 to A9, AA to Z9, B1 to ZZ in order.  
(G, I, J, O, Q, W excluded)

\*No character inversion used.

1. The product and product specifications contained herein are subject to change without notice to improve performance characteristics. Consult us, or our representatives before use, to confirm that the information in this datasheet is up to date.
2. The information in this datasheet is intended to illustrate the operation and characteristics of our products. We neither make warranties or representations with respect to the accuracy or completeness of the information contained in this datasheet nor grant any license to any intellectual property rights of ours or any third party concerning with the information in this datasheet.
3. Applicable export control laws and regulations should be complied and the procedures required by such laws and regulations should also be followed, when the product or any information contained in this datasheet is exported.
4. The product is neither intended nor warranted for use in equipment of systems which require extremely high levels of quality and/or reliability and/or a malfunction or failure which may cause loss of human life, bodily injury, serious property damage including but not limited to devices or equipment used in 1) nuclear facilities, 2) aerospace industry, 3) medical facilities, 4) automobile industry and other transportation industry and 5) safety devices and safety equipment to control combustions and explosions. Do not use the product for the above use unless agreed by us in writing in advance.
5. Although we make continuous efforts to improve the quality and reliability of our products; nevertheless Semiconductors are likely to fail with a certain probability. So in order to prevent personal injury and/or property damage resulting from such failure, customers are required to incorporate adequate safety measures in their designs, such as system fail safes, redundancy and fire prevention features.
6. Our products are not designed to be Radiation-resistant.
7. Please use the product listed in this datasheet within the specified ranges.
8. We assume no responsibility for damage or loss due to abnormal use.
9. All rights reserved. No part of this datasheet may be copied or reproduced unless agreed by Torex Semiconductor Ltd in writing in advance.

TOREX SEMICONDUCTOR LTD.