



Doc. version :2.3
Total pages : 29
Date :2014/12/05

Product Specification

10.1" COLOR TFT-LCD MODULE

< >Preliminary Specification

< >Final Specification

Note: The content of this specification is subject to change.

© 2014 AU Optronics
All Rights Reserved,
Do Not Copy.

A. General Information

This product is for portable DVD and digital photo frame application.

NO.	Item	Unit	Specification	Remark
1	Screen Size	inch	10.1(Diagonal)	
2	Display Resolution	dot	800 RGB (W) x 480(H)	
3	Overall Dimension	mm	235(W) x 145.9(H) x 5.4(D)	Note 1
4	Active Area	mm	219.6(W) x 131.76(H)	
5	Pixel Pitch	mm	0.2745(W) x 0.2745(H)	
6	Color Configuration	--	R. G. B. stripe	Note 2
7	Color Depth	--	262k Colors	Note 3
8	NTSC Ratio	%	48%	
9	Display Mode	--	Normally White	
10	Panel surface Treatment	--	Anti-Glare	
11	Weight	g	315g	
12	LCD Module Power Consumption	W	2.64W	
13	Viewing direction		6 o'clock (gray inversion)	

Note 1: Not include backlight cable and FPC. Refer next page to get further information.

Note 2: Below figure shows dot stripe arrangement.

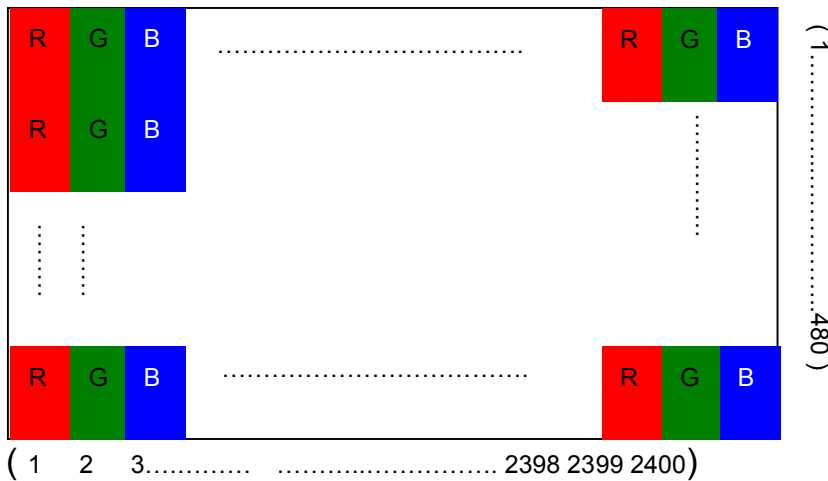

Note 3: The full color display depends on 18-bit data signal (pin 44~67).



B. Outline Dimension
1. TFT-LCD Module – Front View

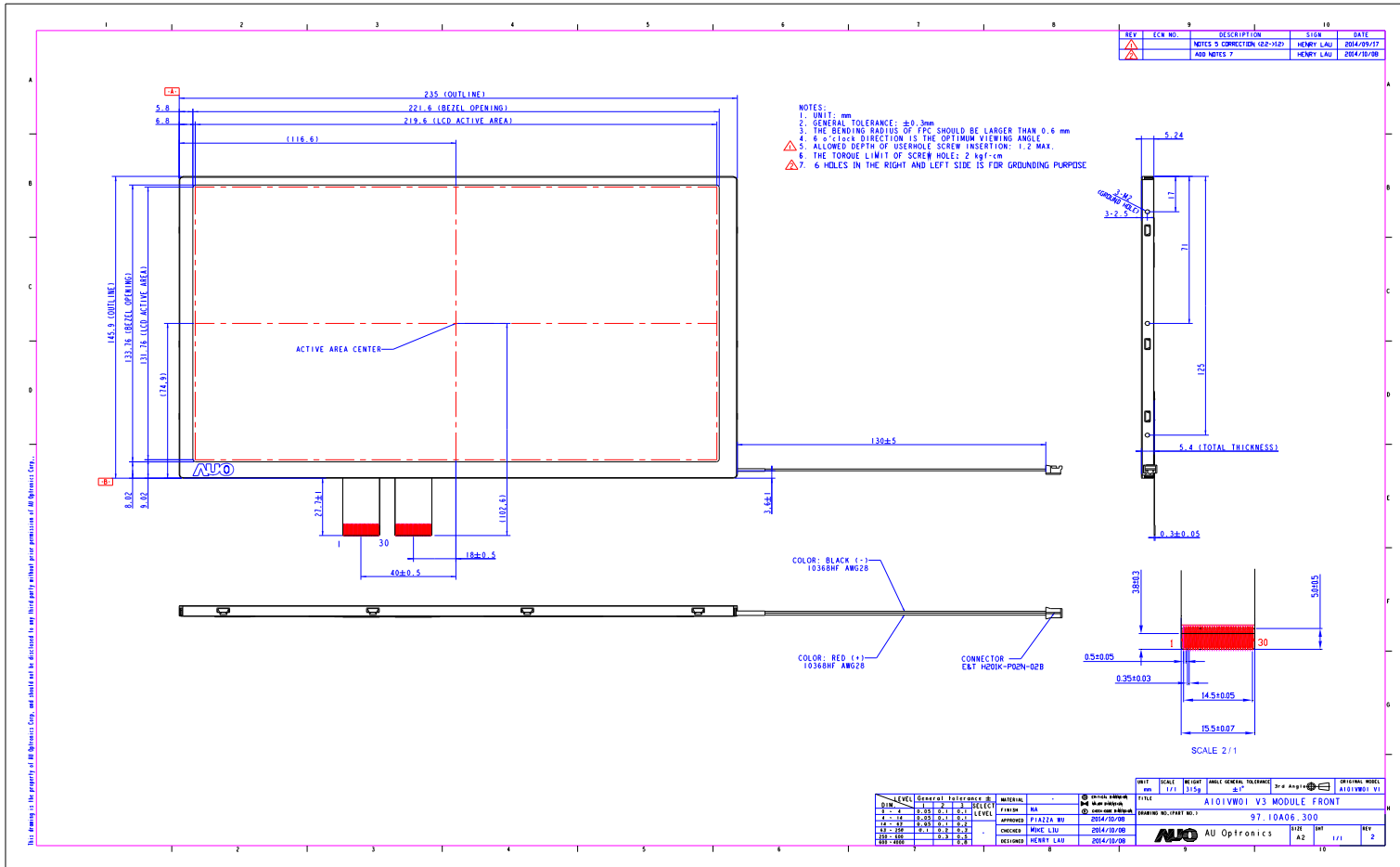

ALL RIGHTS STRICTLY RESERVED. ANY PORTION OF THIS PAPER SHALL NOT BE REPRODUCED, COPIED, OR TRANSFORMED TO ANY OTHER FORMS WITHOUT PERMISSION FROM AU OPTRONICS CORP.

C. Electrical Specifications

1. TFT LCD Panel Pin Assignment

Recommended connector :

Pin no	Symbol	I/O	Description	Remark
1	POL	I	Polarity selection	
2	STVD	I/O	Vertical start pulse signal input or output	Note 1
3	OE	I	Output enable. active low. The gate driver outputs are disable when OE = "H".	
4	CKV	I	Vertical clock	
5	STVU	I/O	Vertical start pulse signal input or output	Note 1
6	GND	P	Power ground	
7	EDGSL	I	Select raising edge or raising/falling edge When EDGSL = "0", Latching source data onto the line latches at the rising edge. When EDGSL = "1", Latching source data onto the line latches at the rising edge and falling edge.	
8	VCC	P	Digital voltage for source driver	
9	V9	I	Gamma voltage level 9	
10	VGL	P	TFT low voltage	
11	V2	I	Gamma voltage level 2	
12	VGH	P	TFT high voltage	
13	V6	I	Gamma voltage level 6	
14	U/D	I	Up/down selection	
15	VCOM	I	Common voltage	
16	GND	P	Power ground	
17	AVDD	P	Analog voltage	
18	V14	I	Gamma voltage level 14	
19	V11	I	Gamma voltage level 11	
20	V8	I	Gamma voltage level 8	
21	V5	I	Gamma voltage level 5	
22	V3	I	Gamma voltage level 3	
23	GND	P	Power ground	
24	R5	I	Red data(MSB)	
25	R4	I	Red data	
26	R3	I	Red data	
27	R2	I	Red data	
28	R1	I	Red data	
29	R0	I	Red data(LSB)	

30	GND	P	Power ground	
31	GND	P	Power ground	
32	G5	I	Green data (MSB)	
33	G4	I	Green data	
34	G3	I	Green data	
35	G2	I	Green data	
36	G1	I	Green data	
37	G0	I	Green data (LSB)	
38	DIO2	I/O	Horizontal start pulse signal input or output	
39	INV	I	Control Whether RGB data are inverted or not When "INV" = 1 these data will be inverted. Ex. "00"→"3F", "07"→"38", and so on.	
40	GND	P	Power ground	
41	DCLK	I	Pixel clock	
42	VCC	P	Voltage for digital circuit	
43	DIO1	I/O	Horizontal start pulse signal input or output	
44	LD	I	Latches the polarity of outputs and switches the new data to outputs	
45	B5	I	Blue data (MSB)	
46	B4	I	Blue data	
47	B3	I	Blue data	
48	B2	I	Blue data	
49	B1	I	Blue data	
50	B0	I	Blue data (LSB)	
51	R/L	I	Right/ left selection	
52	V1	I	Gamma voltage level 1	
53	V4	I	Gamma voltage level 4	
54	V7	I	Gamma voltage level 7	
55	V10	I	Gamma voltage level 10	
56	V12	I	Gamma voltage level 12	
57	V13	I	Gamma voltage level 13	
58	AVDD	P	Analog voltage	
59	GND	P	Power ground	
60	VCOM	I	Common voltage	

I: Input pin; P: Power pin; G: Ground pin; C: capacitor pin

Note 1:

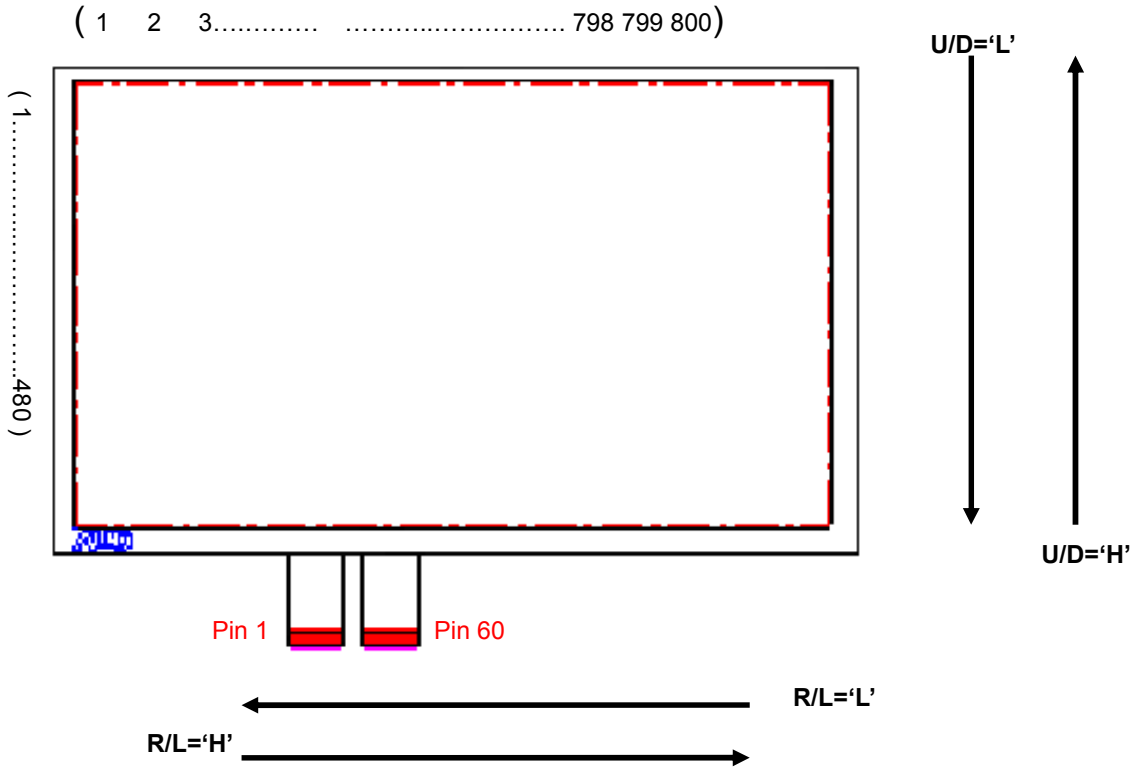

U/D	STVU	STVD	Direction
L	Input	Output	U→D
H	Output	Input	D→U

R/L	DIO1	DIO2	Direction
H	Input	Output	L→R
L	Output	Input	R→L

Note 2: LD

Latches the polarity of outputs and switches the new data to outputs.

1. At the rising edge, latches the "POL" signal to control the polarity of the outputs.
2. The pin also controls the switch of the line registers that switches the new incoming data to outputs.

Note 3: POL

"POL" value is latched at the rising edge of "LD" to control the polarity of the even or odd outputs.

POL=1: Even outputs range from V1 ~ V7, and Odd outputs range from V8 ~ V14

POL=0: Even outputs range from V8 ~ V14, and Odd outputs range from V1 ~ V7

2. Backlight Pin Assignment

Recommended connector :

Manufacturer	Entery
Connector Model Number	E&T H201K-P02N-02B
Mating Connector Model Number	3802-E02N-01R(90degree) or 3801-E02N-01R(180degree)

Pin no	Symbol	I/O	Description	Remark
1	VLED	P	LED power supply	
2	GNDLED	P	LED ground	

3. Absolute Maximum Ratings

Item	Symbol	Condition	Min.	Max.	Unit	Remark
Power voltage	VCC	GND=0	-0.5	5	V	Pin8.42
	AVDD	GND=0	-0.5	12	V	Pin17.58
	VGH	GND=0	-0.3	18	V	Pin12
	VGL	GND=0	-15	+0.3	V	Pin10
	VGH - VGL	GND=0		33	V	
Input signal voltage	Vi	GND=0	-0.3	VCC+0.3	V	Note 2
	Vref(V1~V7)	GND=0	0.4AVDD	AVDD+0.3	V	
	Vref(V8~V14)	GND=0	-0.3	0.6AVDD	V	
	VCOM	GND=0	3.2	4.2	V	Pin15.60
Operating Temperature	Topa	GND=0	-10	60		
Storage Temperature	Tstg	GND=0	-20	70		

Note 1: Functional operation should be restricted under ambient temperature (25).

Note 2: Vi denotes digital input signal voltage (Pins 1~5, 7, 14, 24~29, 32~37, 38, 39, 41, 43, 44, and 45~51).

Note 3: Maximum ratings are those values beyond which damages to the device may occur. Functional



operation should be restricted to the limits in the Electrical Characteristics chapter.

3. Electrical DC Characteristics

a. Typical Operation Condition (AGND =GND = 0V)

Item		Symbol	Min.	Typ.	Max.	Unit	Remark
Power Voltage		VCC	3.0	3.3	3.6	V	Pin8.42
		AVDD	8.4	8.8	9.2	V	Pin17.58
		VGH	14	15	16	V	Pin12
		VGL	-6.8	-7.0	-7.2	V	Pin10
Output Signal Voltage	H Level	VOH	VCCx0.8	--	VCC	V	
	L Level	VOL	GND	--	GNDx0.2	V	
Input Signal Voltage	H Level	VIH	0.7xVCC	--	VCC	V	
	L Level	VIL	GND	--	0.3xVCC	V	
Gamma reference voltage		VCOM	3.5	3.7	3.9	V	Note,Pin15.60
		V1	--	8.60	--	V	Detail Gamma voltage please refer to page 27.
		V2	--	8.48	--		
		V3	--	7.32	--		
		V4	--	6.72	--		
		V5	--	6.27	--		
		V6	--	5.73	--		
		V7	--	5.15	--		
		V8	--	4.29	--		
		V9	--	3.35	--		
		V10	--	2.50	--		
		V11	--	2.03	--		
		V12	--	1.57	--		
		V13	--	0.36	--		
		V14	--	0.15	--		

Note : The VCOM voltage is determined based on gamma 2.2. VCOM should be adjusted to minimize LCM display flicker.

b. Current Consumption (AGND=GND=0V)

Parameter	Symbol	Condition	Min.	Typ.	Max.	Unit	Remark
Input current for VCC	I_{VDD}	VCC=3.3V	-	3.0	5.0	mA	
Input current for VGH	I_{VGH}	VGH=14V	-	231	242	uA	
Input current for VGL	I_{VGL}	VGL= -7V		-244	-256	uA	
Input current for AVDD	I_{VDD}	AVDD=8.8V		32.5	35.0	mA	

Note : Test pattern is the following picture.



c. Backlight Driving Conditions

The backlight (LED module, Note 1) is suggested to drive by constant Voltage with typical value.

Parameter	Symbol	Min.	Typ.	Max.	Unit	Remark
LED light bar Voltage	V_f	--	12	--	Volt	Typ. $I_f=220$ mA
BL Power Consumption	P_{BL}	--	2.64	--	W	Note 1
LED Life Time	L_L	20.000	--	--	Hr	Note 2, 3

Note 1: The LED driving condition is defined for LED module (33 LED). The current range will be 198 to 242mA based on suggested driving voltage set as 12V.

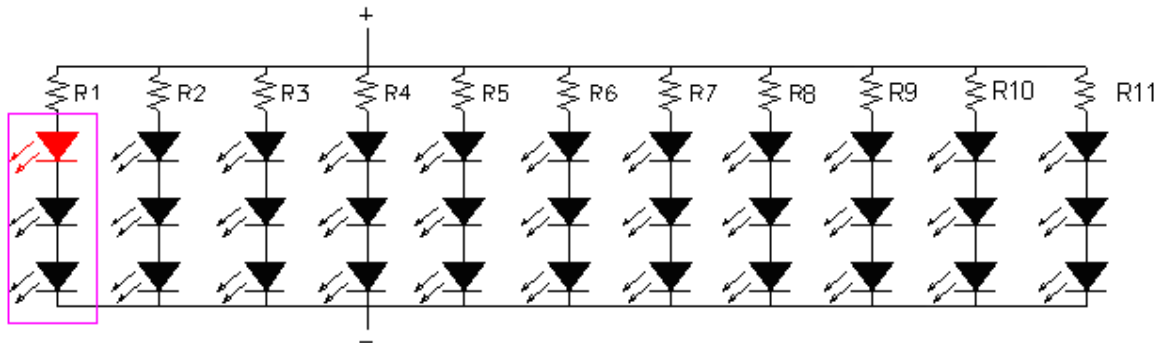

Note 2: Define "LED Lifetime": brightness is decreased to 50% of the initial value. LED Lifetime is restricted under normal condition, ambient temperature = 25 and LED lightbar voltage = 12V.

Note 3: If it uses larger LED lightbar voltage more than 12V, it maybe decreases the LED lifetime.

4. Electrical AC Characteristics

a. Signal AC Characteristics

PARAMETER	SYMBOL	MIN.	TYP.	MAX.	UNIT
DCLK cycle time	Tcph	22.8	30	-	ns
DCLK pulse width	Tcw	40%		60%	Tcph
Data set-up time	Tsu	4			ns
Data hold time	Thd	2			ns
Propagation delay of DIO2/1	Tphl	6	10	15	ns
Time that the last data to LD	Tld	1			Tcph
Pulse width of LD	Twld	2			Tcph
Time that LD to DIO1/2	Tlds	5			Tcph
POL set-up time	Tpsu	6			ns
POL hold time	Tphd	6			ns
STV setup time	Tsuv	200			ns
STV hold time	Thdv	300			ns
CKV pulse width	Tckv	500			ns
Output stable time	Tst			15	us
STV(R/L) width (Note.2)	Tstv	-	1	-	Tpckv
Charging time1 (Note.3)	Tch1	20			us
Charging time2 (Note.3)	Tch2	20			us
OEV cover CKV time1	TOEV1	1			Tcph
OEV cover CKV time2	TOEV2	1			Tcph
Time CKV rising to LD falling	TCTL	2			us
Time OEV rising to LD falling	TOTL	2			us

Note 1: Due to panel is a passive component and no leakage current allowed for better performance, it may need extra circuit to make sure the TFT LCD panel storage capacitor's shorter discharge time when system power off. Customers should study the discharge circuit according to system design.

Note.2: Pulse width of STV(R/L) should be set 1 Tpckv (Time period of CKV).

Note.3: If OEV is used, charging time must be followed to Tch1 setting, at least 20 us. Otherwise, if OEV is unused, charging time must be followed to Tch2 setting, at least 20 us.

Note.4: If OEV is used, TOTL(time from OEV rising edge to LD falling edge) should be set more than 2us to prevent panel from displaying wrong data.

If OEV is unused, TCTL(time from CKV rising edge to LD falling edge) should be set more than 2us to prevent panel from displaying wrong data.

Note.5: If OEV is used, pulse of OEV must cover the rising area of CKV. Therefore, TOEV1 and TOEV2 must be more than 1 Tcph.

Figure : Operation Mode

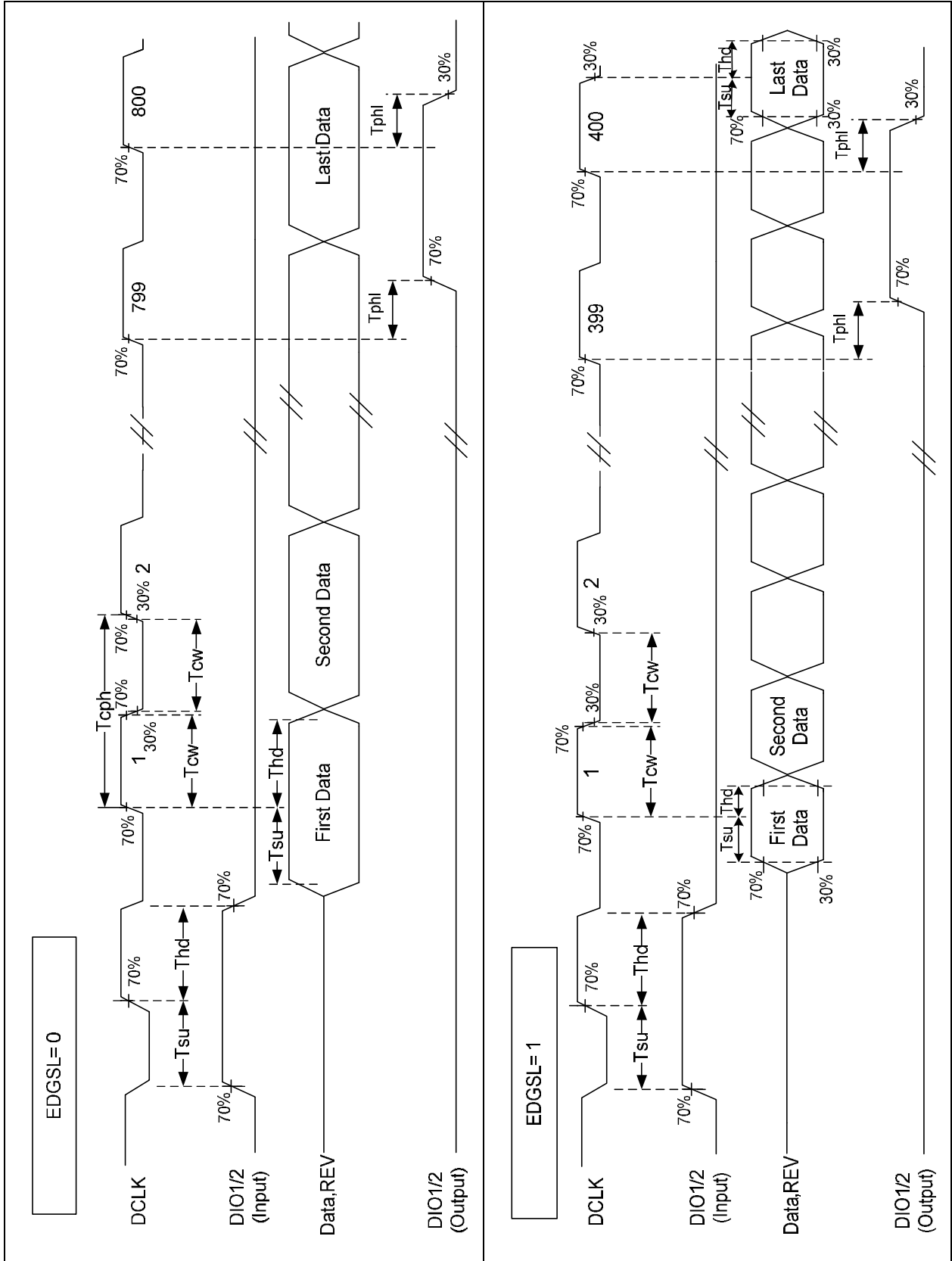

Figure : Horizontal timing

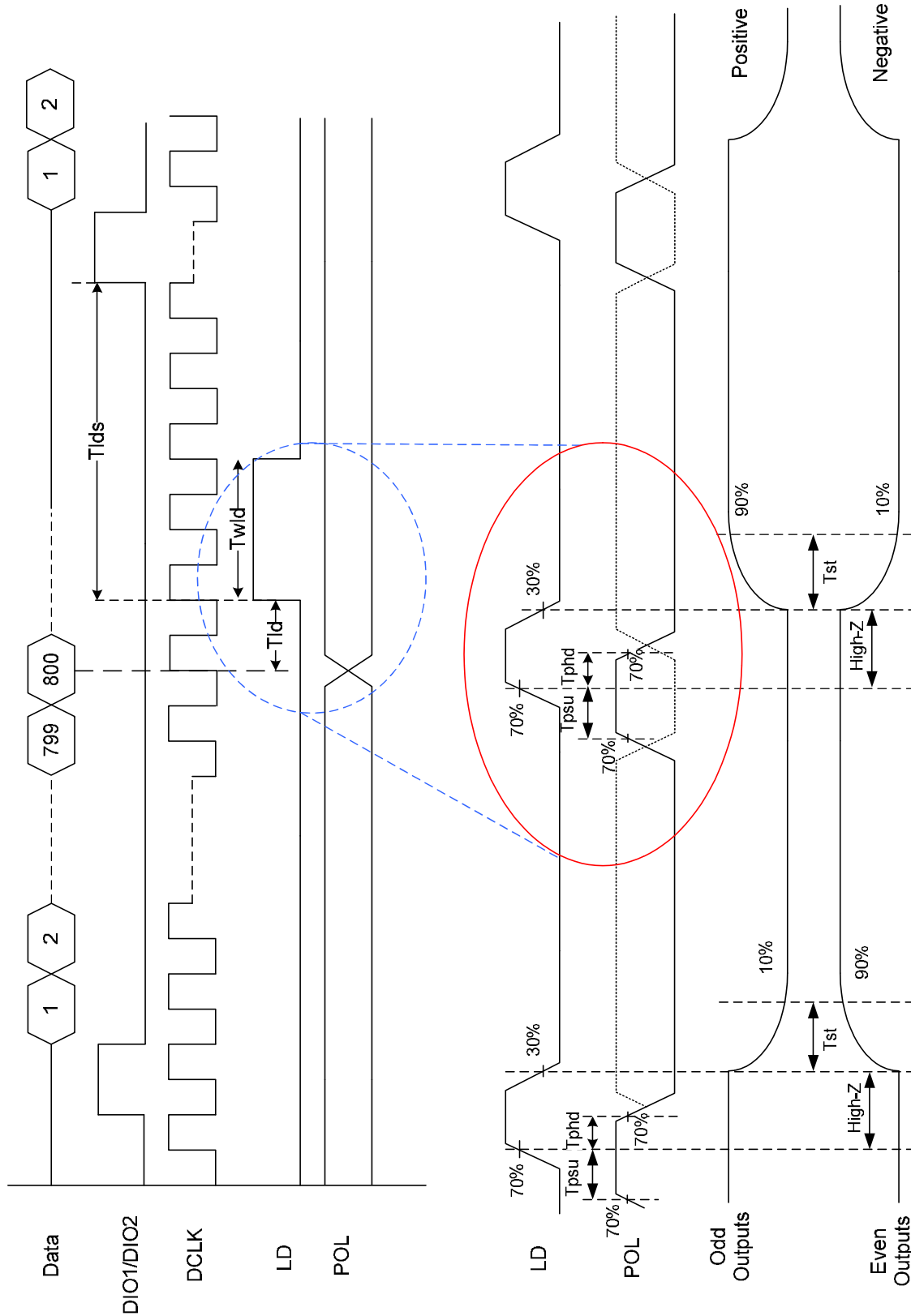

Figure : Vertical timing

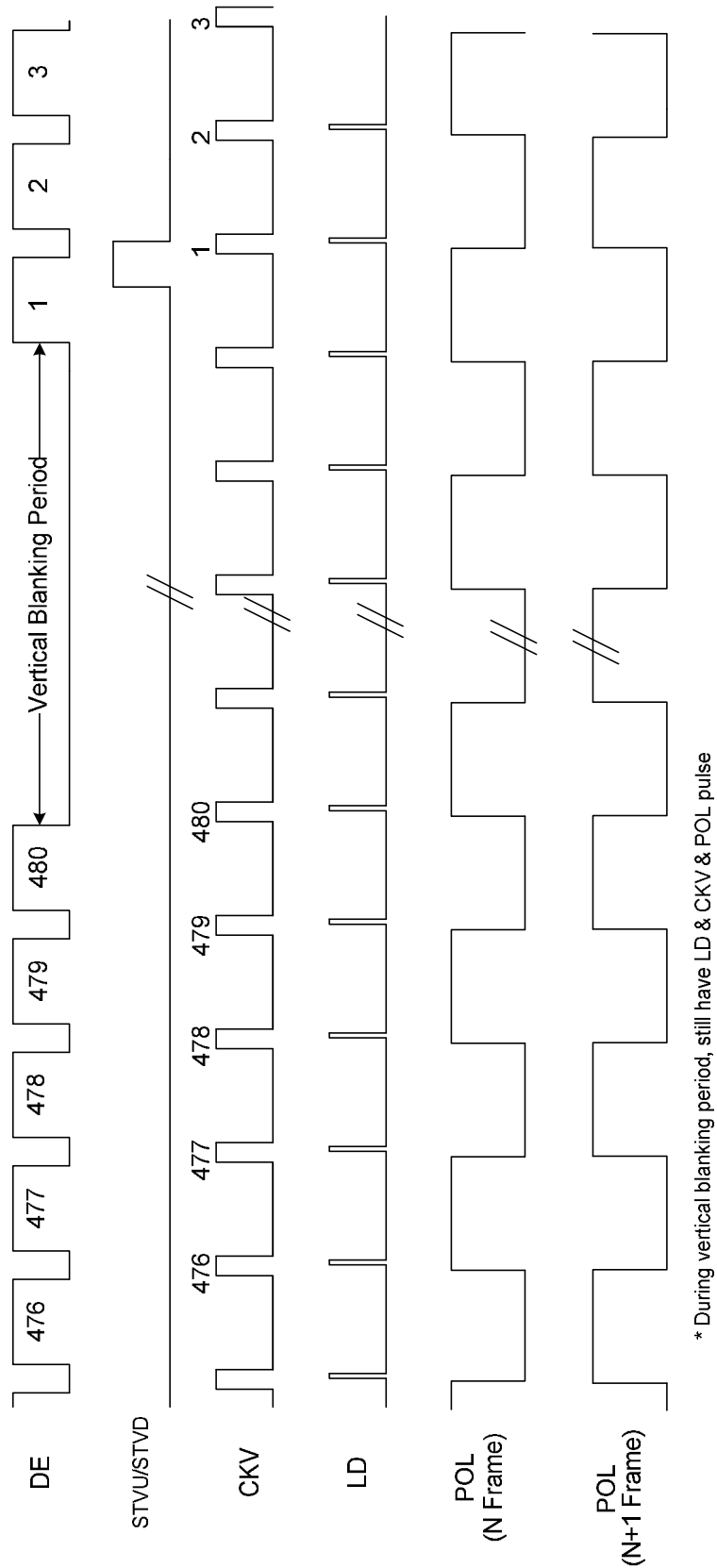

Figure : Vertical shift clock timing

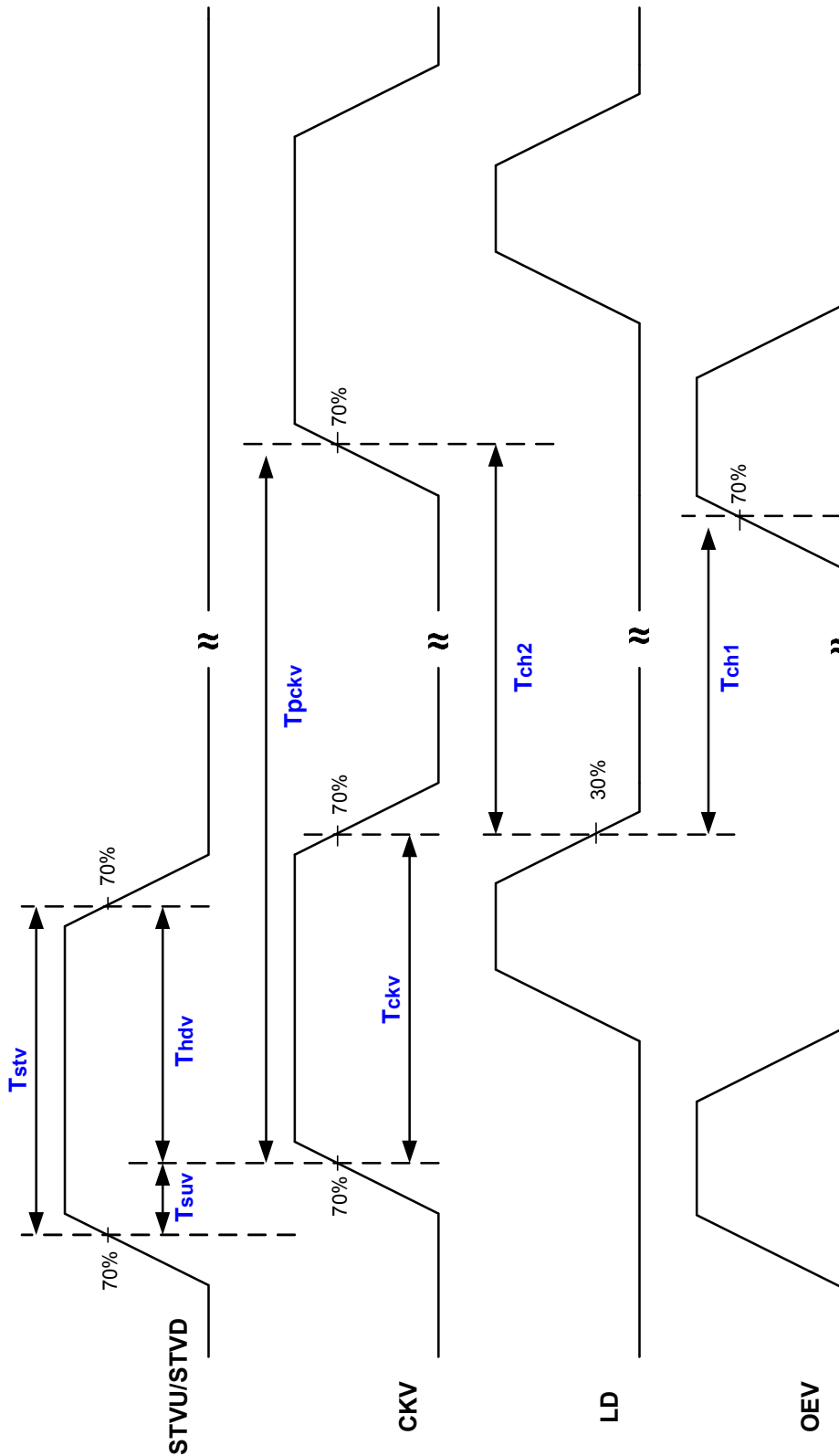
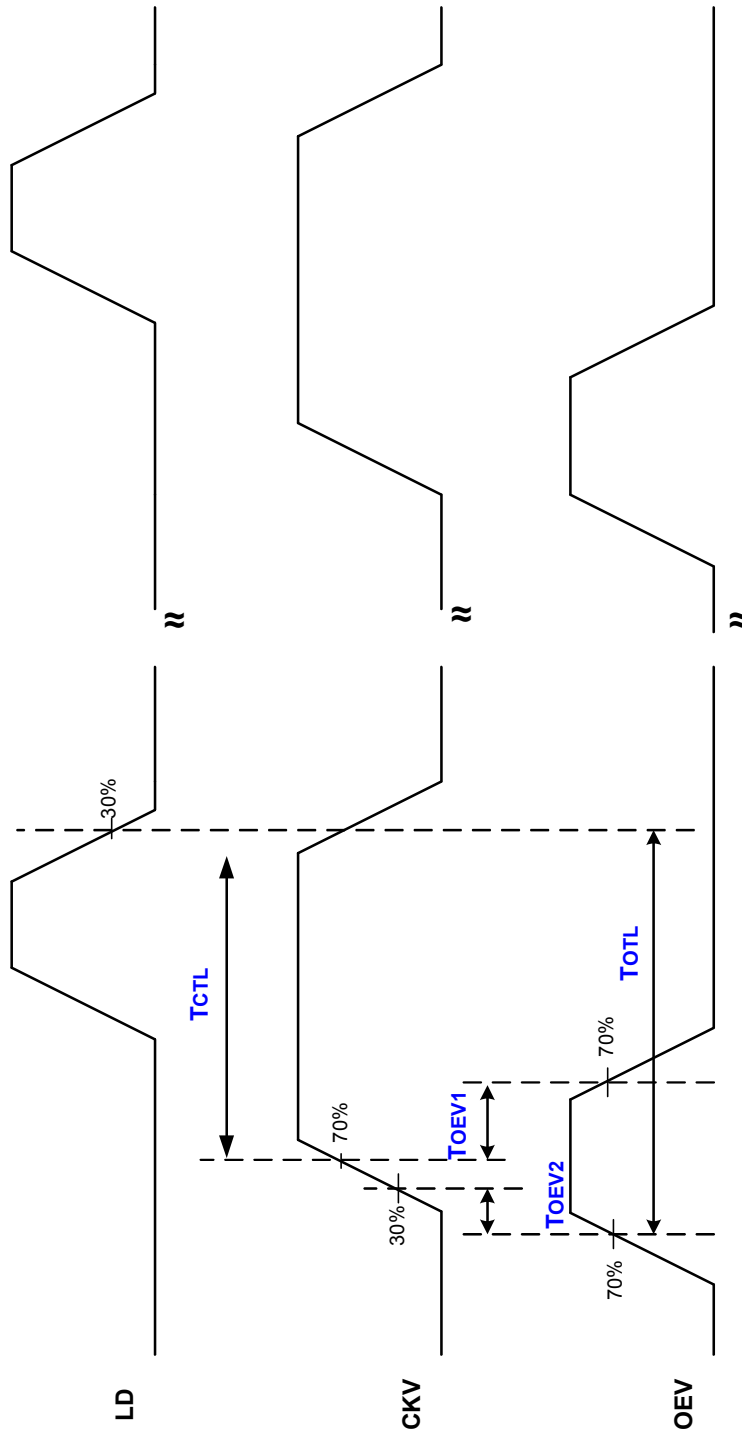
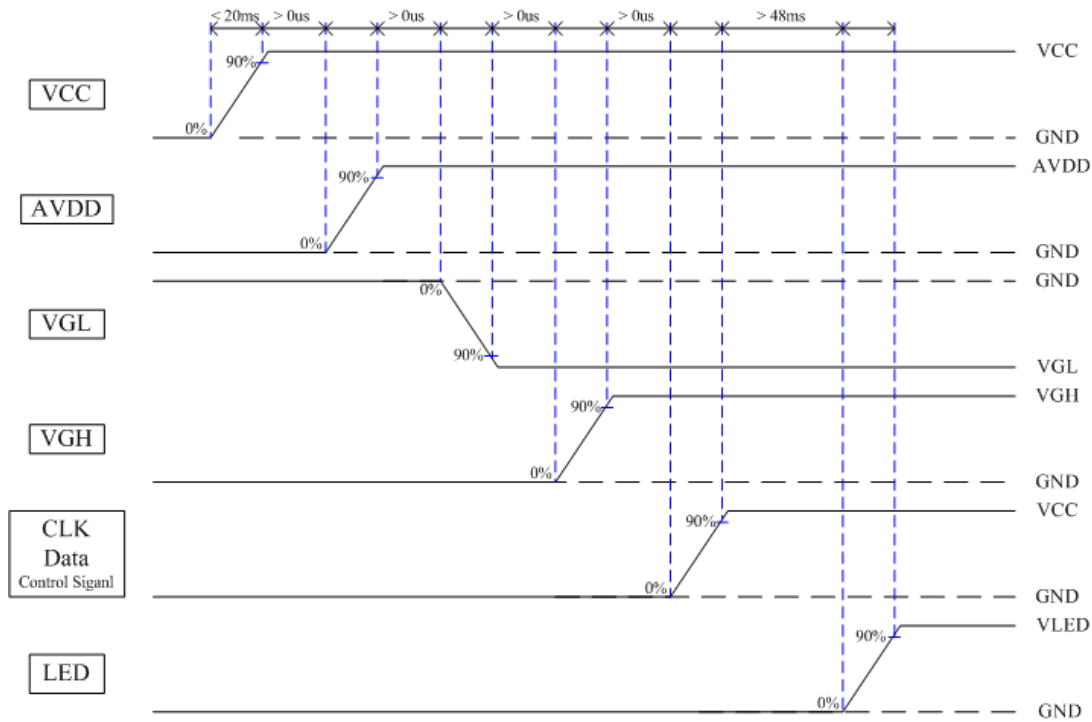

Figure : Vertical shift clock timing



5. Power On/Off Characteristics

a. Recommended Power On Sequence



b. Recommended Power Off Sequence

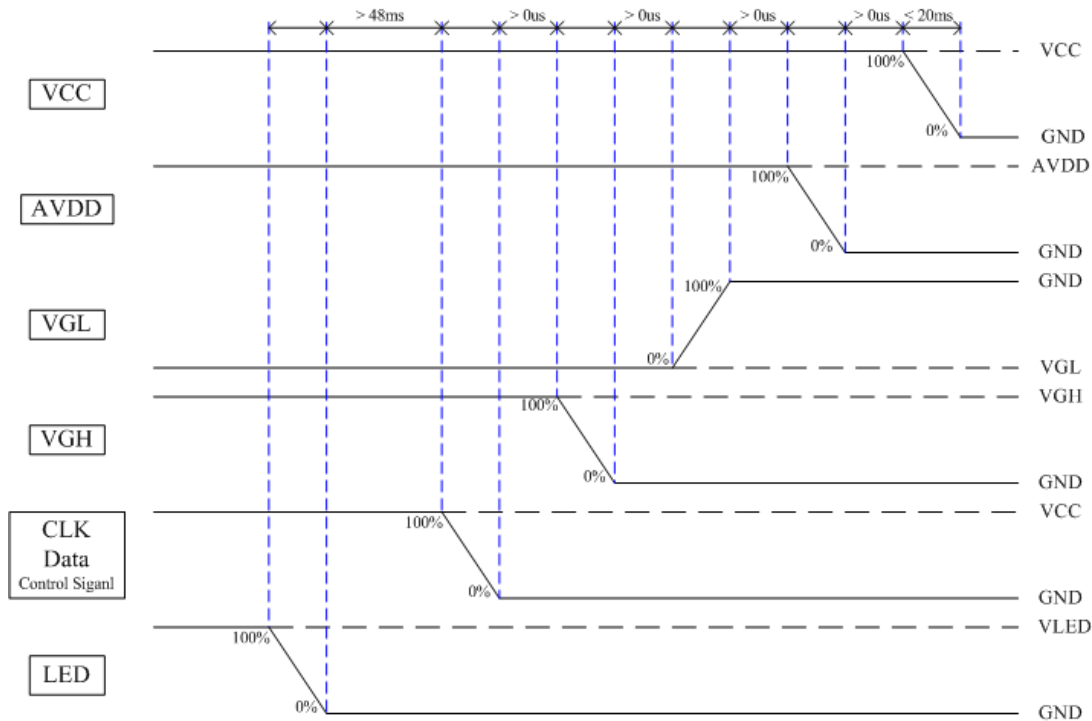

D. Optical Specification

All optical specification is measured under typical condition (Note 1, 2)

Item	Symbol	Condition	Min.	Typ.	Max.	Unit	Remark
Response Time							
Rise	Tr	$\theta=0^\circ$	--	12	24	ms	Note 3
Fall	Tf		--	18	36	ms	
Contrast ratio	CR	At optimized viewing angle	300	500	--		Note 4
Viewing Angle		CR 10				deg.	Note 5
Top			40	45	--		
Bottom			55	65	--		
Left			55	65	--		
Right		55	65	--			
Brightness	Y_L	$\theta=0^\circ$	270	300	--	cd/m ²	Note 6
Chromaticity	White	X	$\theta=0^\circ$	0.26	0.31	0.36	
		Y	$\theta=0^\circ$	0.28	0.33	0.38	
Uniformity	Y_L	%	70	75	--	%	Note 7

Note 1: Ambient temperature =25 , and LED lightbar voltage = 12 V. To be measured in the dark room.

Note 2: To be measured on the center area of panel with a viewing cone of 1° by Topcon luminance meter BM-5A, after 15 minutes operation.

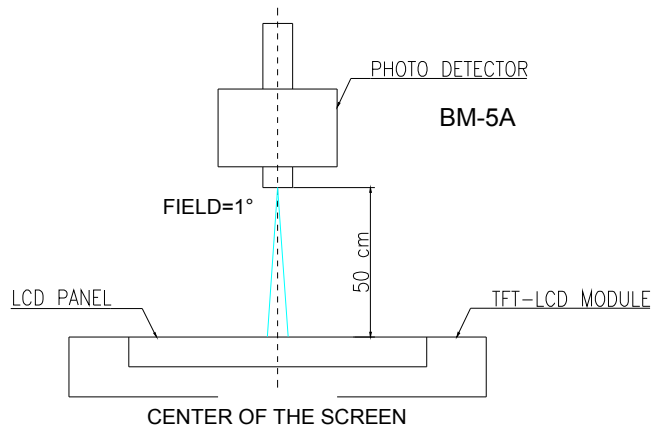

Note 3: Definition of response time:

The output signals of photo detector are measured when the input signals are changed from "black" to "white"(falling time) and from "white" to "black"(rising time), respectively.

The response time is defined as the time interval between the 10% and 90% of amplitudes.

Refer to figure as below.

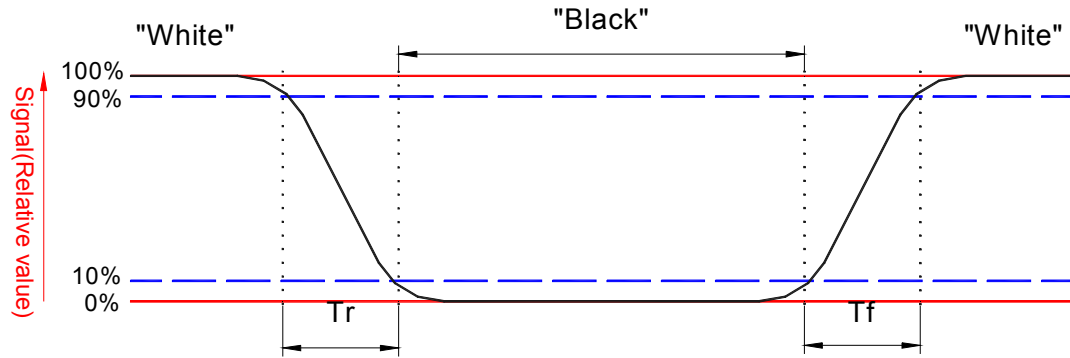

Note 4. Definition of contrast ratio:

Contrast ratio is calculated with the following formula.

$$\text{Contrast ratio (CR)} = \frac{\text{Photo detector output when LCD is at "White" status}}{\text{Photo detector output when LCD is at "Black" status}}$$

Note 5. Definition of viewing angle, θ , Refer to figure as below.

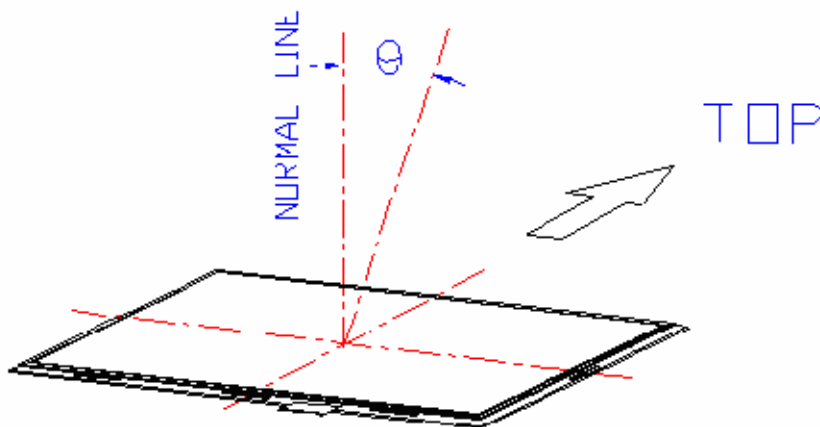

Note 6. Measured at the center area of the panel when all the input terminals of LCD panel are electrically opened.

Note 7: Luminance Uniformity of these 9 points is defined as below:

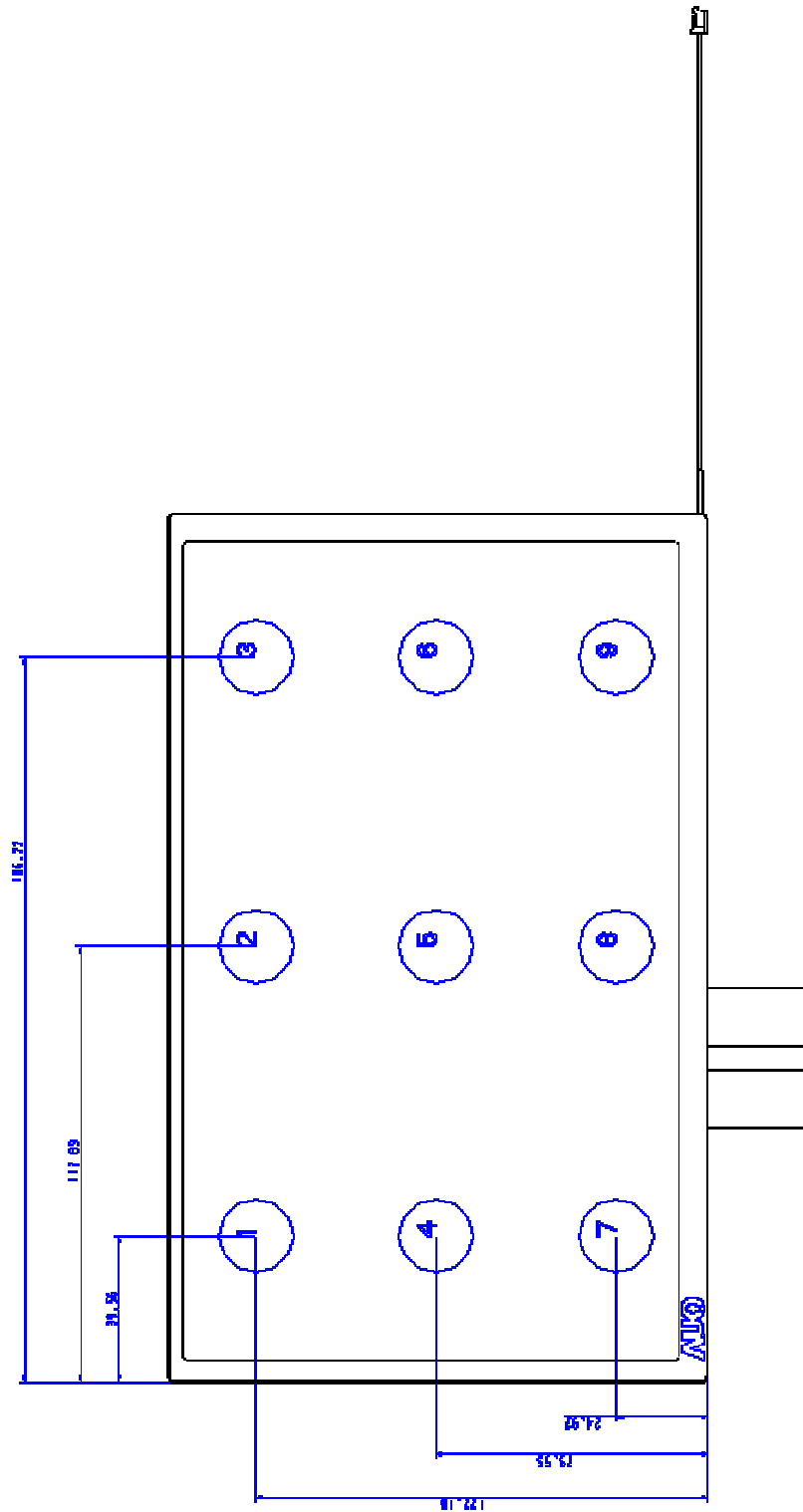

$$\text{Uniformity} = \frac{\text{minimum luminance in 9 points (1-9)}}{\text{maximum luminance in 9 points (1-9)}}$$

E. Reliability Test Items

No.	Test items	Conditions	Remark
1	High Temperature Storage	Ta= 70 240Hrs	
2	Low Temperature Storage	Ta= -20 240Hrs	
3	High Temperature Operation	Tp= 60 240Hrs	
4	Low Temperature Operation	Ta= -10 240Hrs	
5	High Temperature & High Humidity	Tp= 50 . 80% RH 240Hrs	Operation
6	Heat Shock	-30 /0.5hr~70 /0.5hr, 50 cycle	Non-operation
7	Electrostatic Discharge	Contact = ± 4 kV, class B Air = ± 8 kV, class B	Note 4
8	Image Sticking	25 , 24hrs	Note 5
9	Vibration	Frequency range : 10~55Hz Stoke : 1.5mm Sweep : 10 Hz ~55 Hz 2 hours for each direction of X,Y,Z 4 hours for Y direction	Non-operation JIS C7021, A-10 condition A : 15 minutes
10	Mechanical Shock	100G . 6ms, ±X,±Y,±Z 3 times for each direction	Non-operation JIS C7021, A-7 condition C
11	Vibration (With Carton)	Random vibration: 0.015G ² /Hz from 5~200Hz -6dB/Octave from 200~500Hz	IEC 68-34
12	Drop (With Carton)	Height: 100cm 1 corner, 3 edges, 6 surfaces	
13	Pressure	5kg, 5sec	Note 6

Note 1: Ta: Ambient Temperature. Tp: Panel Surface Temperature

Note 2: In the standard conditions, there is not display function NG issue occurred. All the cosmetic specification is judged before the reliability stress.

Note 3: All the cosmetic specification is judged before the reliability stress.

Note 4 : All test techniques follow IEC6100-4-2 standard.

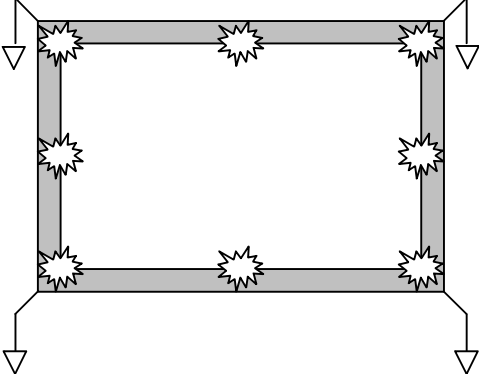
Test Condition		Note
<p>Pattern</p>		
<p>Procedure And Set-up</p>	<p><u>Contact Discharge</u> : 330Ω, 150pF, 1sec, 8 point, 25times/point <u>Air Discharge</u> : 330Ω, 150pF, 1sec, 8 point, 25times/point</p> 	
<p>Criteria</p>	<p>B – Some performance degradation allowed. No data lost. Self-recoverable hardware failure.</p>	
<p>Others</p>	<ol style="list-style-type: none"> 1. Gun to Panel Distance 2. No SPI command, keep default register settings. 	

Note 5: Operate with 5 x 5 chess board pattern as figure and light on 24 hrs. Then modify to 32 degree gray pattern. After 20 minutes, the mura is less than JND 2.5

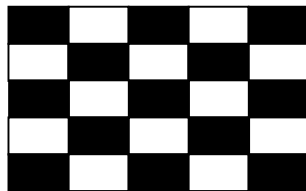

Note 6: The panel is tested as figure. The jig is 10 mm made by Cu with rubber and the loading speed is 3mm/min on position A~E. After the condition, no glass crack will be found and panel function check is OK.(no guarantee LC mura、LC bubble)

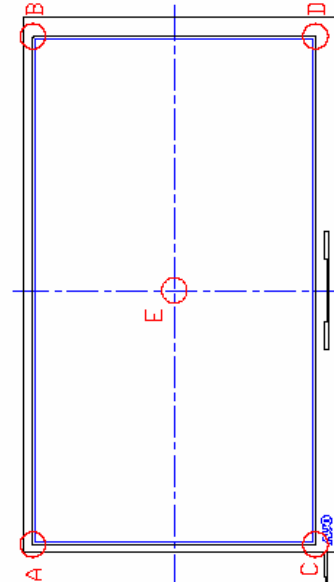
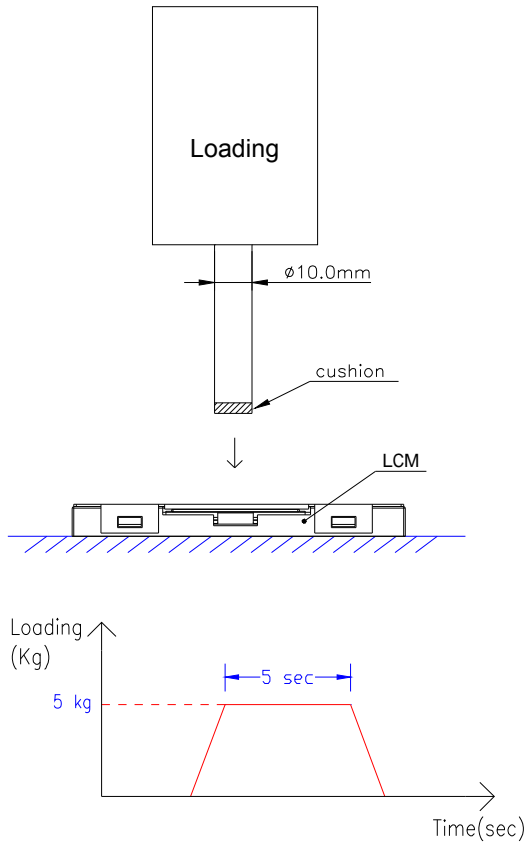

F. Packing and Marking

1. Packing Form

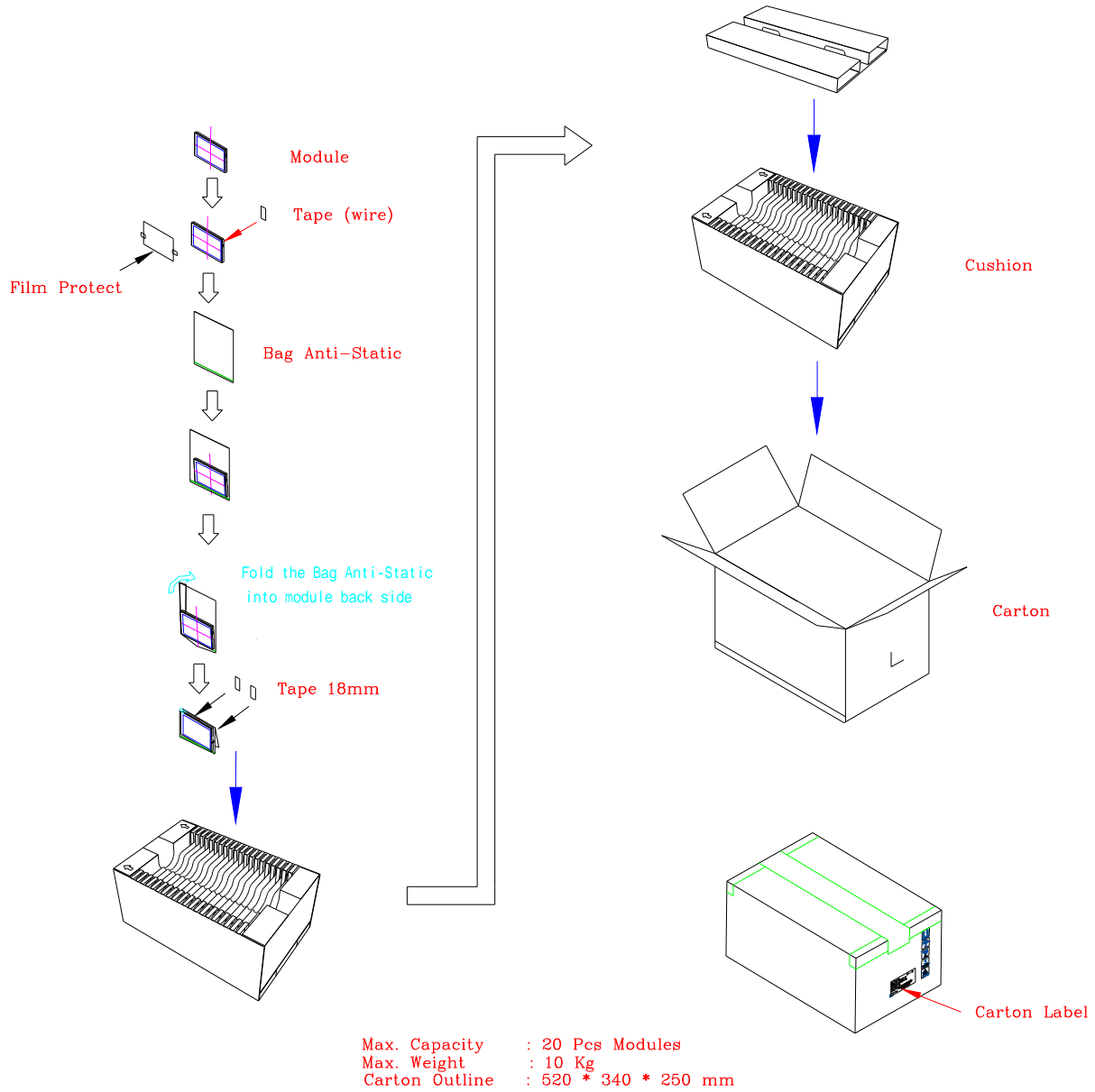

2. Module/Panel Label Information

The module/panel (collectively called as the “Product”) will be attached with a label of Shipping Number which represents the identification of the Product at a specific location. Refer to the Product outline drawing for detailed location and size of the label. The label is composed of a 22-digit serial number and printed with code 128 with the following definition:

ABCDEFGHIJKLMN OPQRST UV

- For internal system usage and production serial numbers.
- AUO Module or Panel factory code, represents the final production factory to complete the Product
- Product version code, ranging from 0~9 or A~Z (for Version after 9)
- Week Code, the production week when the product is finished at its production process

Example:

501M06ZL06123456781Z05:

Product Manufacturing Week Code: WK50

Product Version: Version 1

Product Manufacturing Factory: M06

3. Carton Label Information

The packing carton will be attached with a carton label where packing Q'ty, AUO Model Name, AUO Part Number, Customer Part Number (Optional) and a series of Carton Number in 13 or 14 digits are printed. The Carton Number is appearing in the following format:

ABC-DEFG-HIJK-LMN

- DEFG appear after first "-" represents the packing date of the carton
- Date from 01 to 31
- Month, ranging from 1~9, A~C. A for Oct, B for Nov and C for Dec.
- A.D. year, ranging from 1~9 and 0. The single digit code represents the last number of the year

Refer to the drawing of packing format for the location and size of the carton label.

G. Application Note

1. Recommended Gamma Voltage

Symbol	Value (V)
V1	8.60
V2	8.48
V3	7.32
V4	6.72
V5	6.27
V6	5.73
V7	5.15
V8	4.29
V9	3.35
V10	2.50
V11	2.03
V12	1.57
V13	0.36
V14	0.15
AVDD	8.8
VCOM	3.7

Recommend resister value:

Symbol	Value (Ohm)
R1	16
R2	158
R3	82.5
R4	64.9
R5	75
R6	102
R7	110
R8	220
R9	124
R10	68
R11	62
R12	165
R13	30
R14	19.1

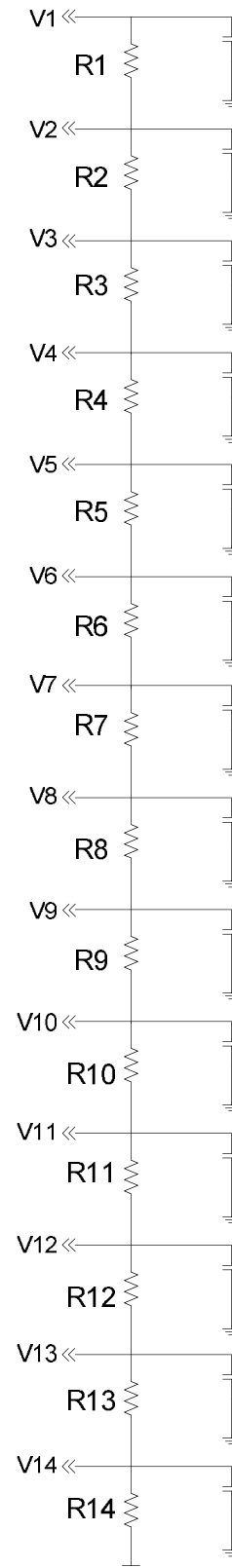

H. Precautions

1. Do not twist or bend the module and prevent the unsuitable external force for display module during assembly.
2. Adopt measures for good heat radiation. Be sure to use the module with in the specified temperature.
3. Avoid dust or oil mist during assembly.
4. Follow the correct power sequence while operating. Do not apply the invalid signal, otherwise, it will cause improper shut down and damage the module.
5. Please operate module in suitable temperature. The response time & brightness will drift by different temperature.
6. Avoid to display the fixed pattern (exclude the white pattern) in a long period, otherwise, it will cause image sticking.
7. Be sure to turn off the power when connecting or disconnecting the circuit.
8. Polarizer scratches easily, please handle it carefully.
9. Display surface never likes dirt or stains.
10. A dewdrop may lead to destruction. Please wipe off any moisture before using module.
11. Sudden temperature changes cause condensation, and it will cause polarizer damaged.
12. High temperature and humidity may degrade performance. Please do not expose the module to the direct sunlight and so on.
13. Acetic acid or chlorine compounds are not friends with TFT display module.
14. Static electricity will damage the module, please do not touch the module without any grounded device.
15. Do not disassemble and reassemble the module by self.
16. Be careful do not touch the rear side directly.
17. No strong vibration or shock. It will cause module broken.
18. Storage the modules in suitable environment with regular packing.
19. Be careful of injury from a broken display module.
20. Please avoid the pressure adding to the surface (front or rear side) of modules, because it will cause the display non-uniformity or other function issue.