

Platinum Resistance Temperature Detector

L 220 P

L series PRTDs are designed for large volume applications where long term stability, interchangeability and accuracy over a large temperature range are vital. Typical applications are Automotive, White goods, HVAC, Energy management, Medical and Industrial equipment.

Nominal Resistance R0	Tolerance DIN EN 60751 1996-07	Tolerance DIN EN 60751 2009-05	Order Number Plastic Box	Order Number Vacuum bag
100 Ohm at 0°C	Class B	F 0.3	32 207 302	32 207 608

The measuring point for the nominal resistance is defined at 8mm from the end of the sensor body.

Specification	DIN EN 60751 (according to IEC 751)	
Temperature range	-50°C to +400°C (continuous operation) Tolerance class B: -50°C to +400°C	
Temperature coefficient	TCR = 3850 ppm/K	
Leads	AgPd- wire	
Lead lengths (L)	10mm ±1mm	
Long-term stability	max. R ₀ -drift 0.04% after 1000h at 400°C	
Vibration resistance	at least 40g acceleration at 10 to 2000 Hz, depends on installation	
Shock resistance	at least 100g acceleration with 8ms half sine wave, depends on installation	
Environmental conditions	unhoused for dry environments only	
Insulation resistance	> 100 MΩ at 20°C; > 2 MΩ at 400°C	
Self heating	0.4 K/mW at 0°C	
Response time	water current (v= 0.4m/s):	t _{0.5} = 0.20s t _{0.9} = 0.30s
	air stream (v= 2m/s):	t _{0.5} = 3.0s t _{0.9} = 9.0s
Measuring current	100Ω: 0.3 to 1.0mA (self heating has to be considered)	
Note	Other tolerances, values of resistance and wire lengths are available on request.	

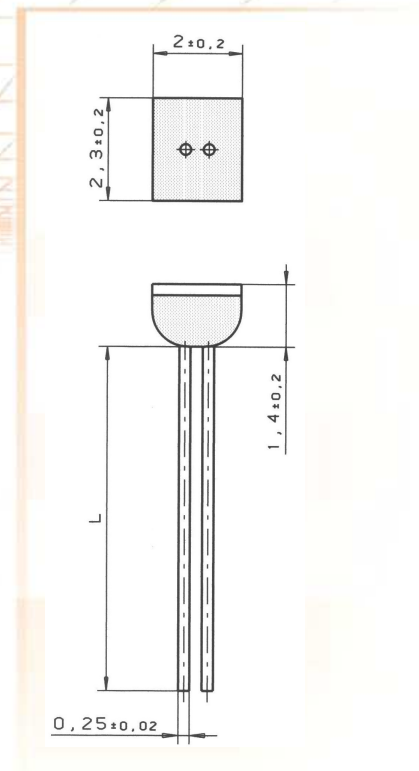

We reserve the right to make alterations and technical data printed. All technical data serves as a guideline and does not guarantee particular properties to any products.

Heraeus Sensor Technology USA

1901 Route 130
North Brunswick, NJ 08902
Phone 732-940-4400 Fax 732-940-4445
Email info.hst-us@heraeus.com
www.hst-us.com

Name of document: 30910005 Index A
Status: 10/2009