

# ASSR-301C and ASSR-302C

## Low C x R, Form A, Solid State Relay (Photo MOSFET)

### (250V/50Ω/15pF)



## Data Sheet



### Description

The ASSR-30xC Series is specifically designed for fast switching applications, commonly found in the test and measurement systems. The low C x R and low output off-state leakage current provide higher system throughput and reduce system errors.

The dual channel configuration of ASSR-302C is equivalent to 2 Form A Electromechanical Relays (EMR). One channel of the relay consists of an AlGaAs infrared light-emitting diode (LED) input stage optically coupled to a high-voltage output detector circuit. The detector consists of a high-speed photovoltaic diode array and driver circuitry to switch on/off two discrete high-voltage MOSFETs. The relay turns on (contact closes) with a minimum input current of 1mA through the input LED. The relay turns off (contact opens) with an input voltage of 0.8V or less.

ASSR-301C is available in 4-pin SO package and ASSR-302C is available in 8-pin DIP and Gull Wing Surface Mount packages. Their electrical and switching characteristics are specified over the temperature range of -40°C to +85°C.

### Functional Diagram

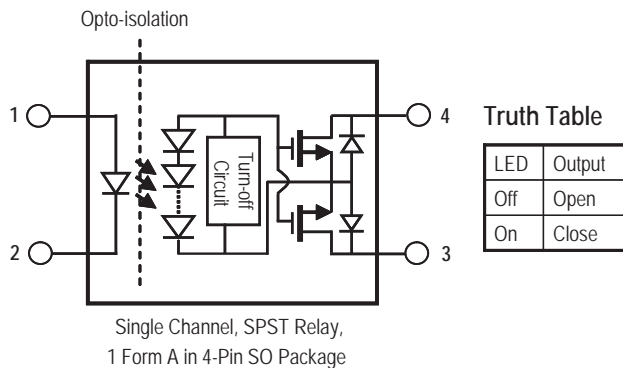

### Features

- Compact Solid-State Bi-directional Signal Switch
- Single and Dual Channel Normally-off Single-Pole-Single-Throw (SPST) Relay
- 250V Output Withstand Voltage
- 0.05A Current Rating
- Low Input Current:  $I_F = 1\text{mA}$
- Low C x R: 340pF•Ω typical
- Low Output Off-state Leakage Current: 0.3nA typical
- Fast Speed Switching: 0.07ms (Ton), 0.07ms (Toff) typical
- High Transient Immunity: >1kV/μs
- High Input-to-Output Insulation Voltage (Safety and Regulatory Approvals Pending)
  - 3750 Vrms for 1 min per UL1577
  - CSA Component Acceptance

### Applications

- Automatic Test Equipment
- Data Acquisition System
- Datalogger and Recorder
- Multiplexer
- Measuring Instrument
- EMR / Reed Relay Replacement

**CAUTION:** It is advised that normal static precautions be taken in handling and assembly of this component to prevent damage and/or degradation which may be induced by ESD.

## Ordering Information

ASSR-xxxx is UL Recognized with 3750 Vrms for 1 minute per UL1577 and is approved under CSA Component Acceptance Notice #5.

Part number	Option	Package	Surface Mount	Gull Wing	Tape & Reel	Quantity
	RoHS Compliant					
ASSR-301C	-003E	SO-4	X			100 units per tube
	-503E		X		X	1500 units per reel
ASSR-302C	-002E	300 mil DIP-8				50 units per tube
	-302E		X	X		50 units per tube
	-502E		X	X	X	1000 units per reel

To order, choose a part number from the part number column and combine with the desired option from the option column to form an order entry.

Example 1:

ASSR-301C-503E to order product of Surface Mount SO-4 package in Tape and Reel packaging and RoHS Compliant.

Example 2:

ASSR-302C-002E to order product of 300mil DIP-8 package in tube packaging and RoHS Compliant.

Option datasheets are available. Contact your Avago sales representative or authorized distributor for information.

## Schematic

### ASSR-301C

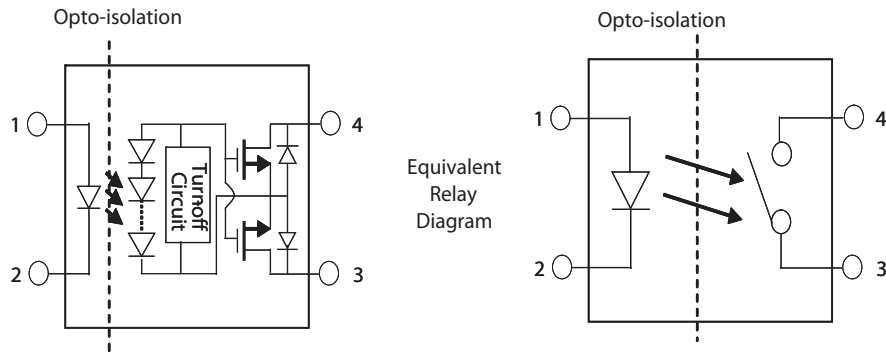

### ASSR-302C

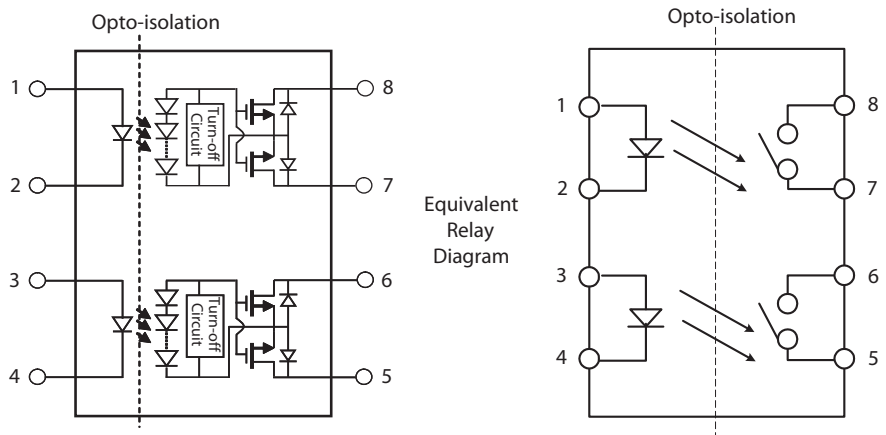

## Package Outline Drawings

### ASSR-301C 4-Pin Small Outline Package

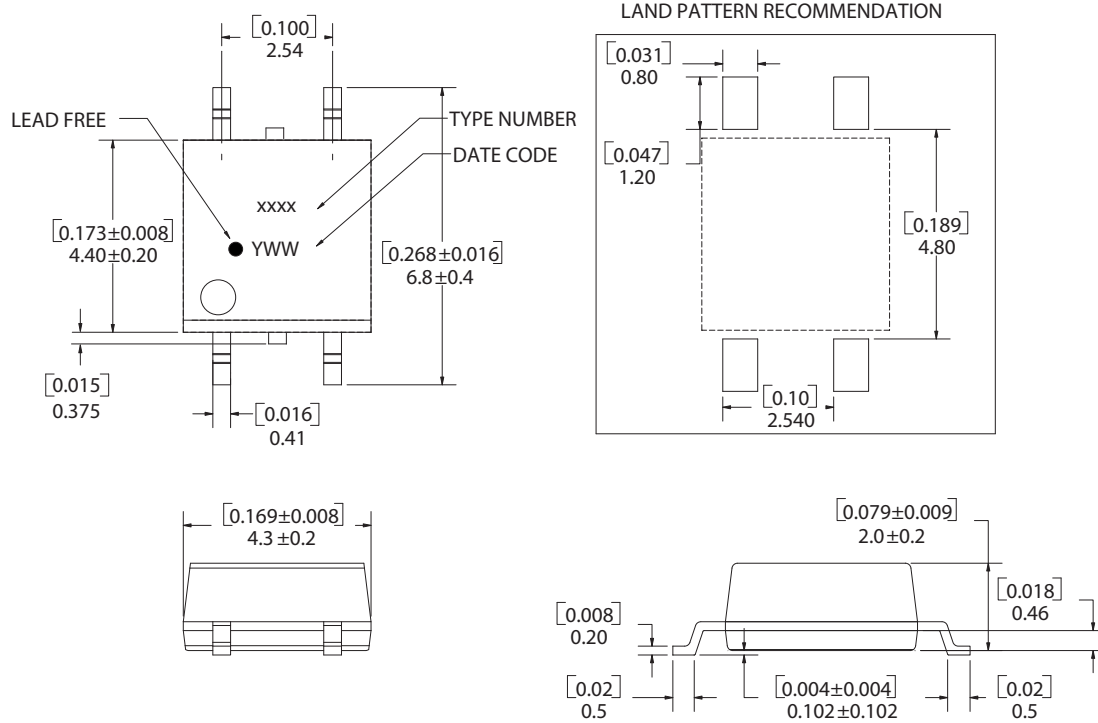

DIMENSIONS IN MILLIMETERS AND [INCHES]  
 OPTION NUMBER 500 AND UL RECOGNITION NOT MARKED

### ASSR-302C 8-Pin DIP Package

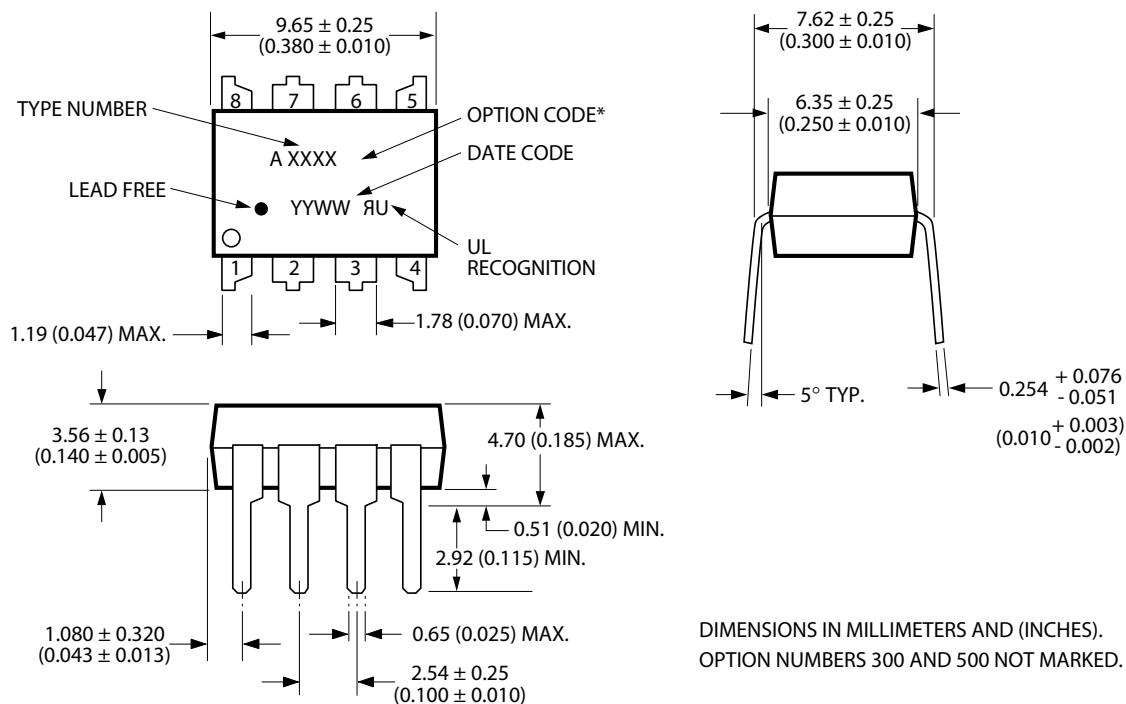

DIMENSIONS IN MILLIMETERS AND (INCHES).  
 OPTION NUMBERS 300 AND 500 NOT MARKED.

**ASSR-302C 8-Pin DIP Package with Gull Wing Surface Mount Option 300**

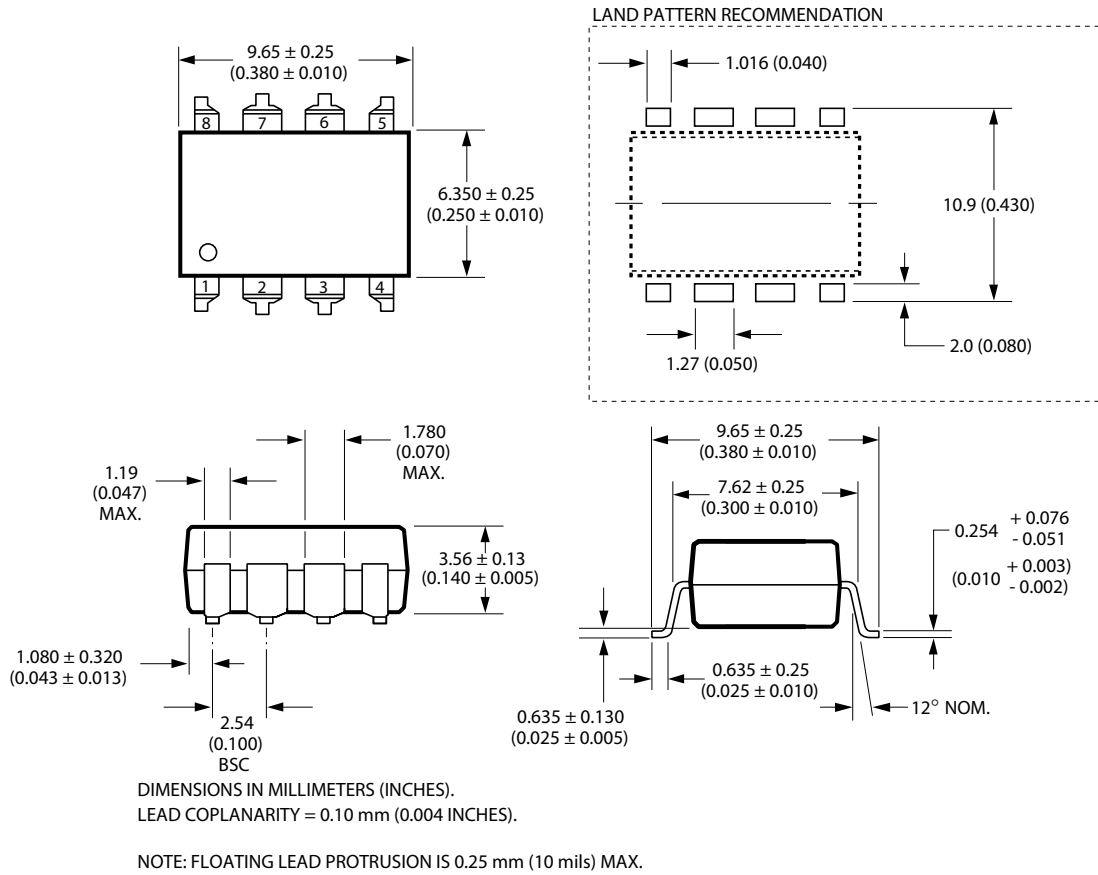

**Lead Free IR Profile**

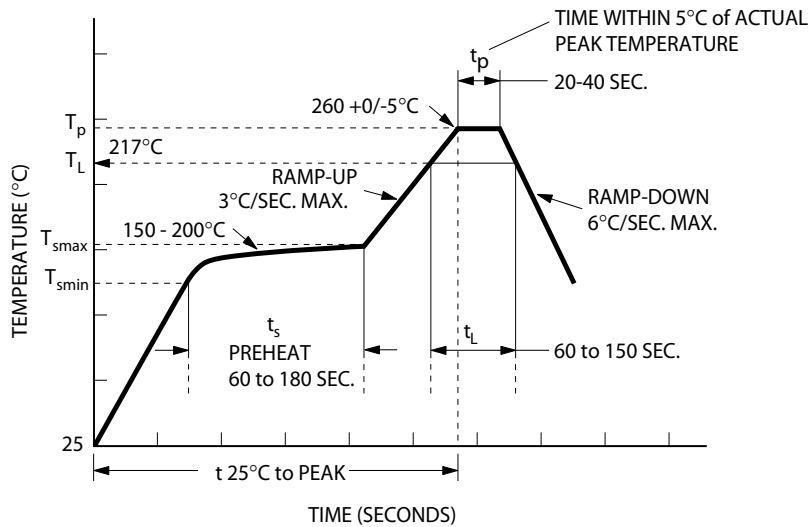

NOTES:  
 THE TIME FROM 25°C TO PEAK TEMPERATURE = 8 MINUTES MAX.  
 $T_{smax} = 200^{\circ}C$ ,  $T_{smin} = 150^{\circ}C$

Use of non-chlorine-activated fluxes is highly recommended.

## Regulatory Information

The ASSR-301C and ASSR-302C are approved by the following organizations:

### UL

Approved under UL 1577, component recognition program up to  $V_{ISO} = 3750 V_{RMS}$

### CSA

Approved under CSA Component Acceptance Notice #5.

## Insulation and Safety Related Specifications

Parameter	Symbol	ASSR-301C	ASSR-302C	Units	Conditions
Minimum External Air Gap (Clearance)	L(101)	4.9	7.1	mm	Measured from input terminals to output terminals, shortest distance through air.
Minimum External Tracking (Creepage)	L(102)	4.9	7.4	mm	Measured from input terminals to output terminals, shortest distance path along body.
Minimum Internal Plastic Gap (Internal Clearance)		0.08	0.08	mm	Through insulation distance conductor to conductor, usually the straight line distance thickness between the emitter and detector.
Tracking Resistance (Comparative Tracking Index)	CTI	175	175	V	DIN IEC 112/VDE 0303 Part 1
Isolation Group (DIN VDE0109)		IIIa	IIIa		Material Group (DIN VDE0109)

## Absolute Maximum Ratings

Parameter	Symbol	Min.	Max.	Units	Note
Storage Temperature	$T_S$	-55	125	°C	
Operating Temperature	$T_A$	-40	85	°C	
Junction Temperature	$T_J$		125	°C	
Lead Soldering Cycle	Temperature Time		260 10	°C s	
Input Current	Average Surge Transient	$I_F$	25 50 1000	mA	
Reversed Input Voltage	$V_R$		5V		
Input Power Dissipation	ASSR-301C ASSR-302C	$P_{IN}$	20 40	mW	
Output Power Dissipation	ASSR-301C ASSR-302C	$P_O$	125 250	mW	
Average Output Current ( $T_A = 25^\circ\text{C}$ , $T_C \leq 100^\circ\text{C}$ )	$I_O$		0.05	A	
Output Voltage ( $T_A = 25^\circ\text{C}$ )	$V_O$	-250	250	V	
Solder Reflow Temperature Profile		See Lead Free IR Profile			

## Recommended Operating Conditions

Parameter	Symbol	Min.	Max.	Units	Note
Input Current (ON)	$I_{F(ON)}$	1	10	mA	1
Input Voltage (OFF)	$V_{F(OFF)}$	0	0.8	V	
Operating Temperature	$T_A$	-40	+85	°C	

## Package Characteristics

Unless otherwise specified,  $T_A = 25^\circ\text{C}$ .

Parameter	Sym.	Min.	Typ.	Max.	Units	Conditions	Note
Input-Output Momentary Withstand Voltage	$V_{ISO}$	3750			Vrms	RH ≤ 50%, t = 1 min	2, 3
Input-Output Resistance	$R_{I-O}$		$10^{12}$		Ω	$V_{I-O} = 500\text{ Vdc}$	
Input-Output Capacitance ASSR-301C ASSR-302C	$C_{I-O}$		0.4 0.8		pF	f = 1 MHz; $V_{I-O} = 0\text{ Vdc}$	2

## Electrical Specifications (DC)

Over recommended operating  $T_A = -40^\circ\text{C}$  to  $85^\circ\text{C}$ , unless otherwise specified.

Parameter	Sym.	Min.	Typ.	Max.	Units	Conditions	Note
Output Withstand Voltage	$ V_{O(OFF)} $	250	280		V	$V_F = 0.8\text{V}$ , $I_O = 250\ \mu\text{A}$ , $T_A = 25^\circ\text{C}$	
		230			V	$V_F = 0.8\text{V}$ , $I_O = 250\ \mu\text{A}$	
Output Leakage Current	$I_{O(OFF)}$		0.3	10	nA	$V_F = 0.8\text{V}$ , $V_O = 250\text{V}$ , $T_A = 25^\circ\text{C}$	4
				1	μA	$V_F = 0.8\text{V}$ , $V_O = 250\text{V}$	4
Output Off-Capacitance	$C_{(OFF)}$		10	15	pF	$V_F = 0.8\text{V}$ , $V_O = 0\text{V}$ , Freq=1 MHz	
Output Offset Voltage	$ V_{(OS)} $				μV	$I_F = 5\text{mA}$ , $I_O = 0\text{mA}$	
Input Reverse Breakdown Voltage	$V_R$	5V				$I_R = 10\ \mu\text{A}$	
Input Forward Voltage	$V_F$	1.1	1.3	1.65	V	$I_F = 5\text{mA}$	
Output On-resistance	$R_{(ON)}$		34	50	Ω	$I_F = 5\text{mA}$ , $I_O = 50\text{mA}$ , Pulse ≤ 30ms, $T_A = 25^\circ\text{C}$	5

## Switching Specifications (AC)

Over recommended operating  $T_A = -40^{\circ}\text{C}$  to  $85^{\circ}\text{C}$ , unless otherwise specified.

Parameter	Sym.	Min.	Typ.	Max.	Units	Conditions	Note
Turn On Time	$T_{ON}$		0.07	0.2	ms	$I_F = 5\text{mA}$ , $I_O = 50\text{mA}$ , $T_A = 25^{\circ}\text{C}$	
				0.5	ms	$I_F = 5\text{mA}$ , $I_O = 50\text{mA}$	
			0.15	0.5	ms	$I_F = 2\text{mA}$ , $I_O = 50\text{mA}$ , $T_A = 25^{\circ}\text{C}$	
				0.8	ms	$I_F = 2\text{mA}$ , $I_O = 50\text{mA}$	
Turn Off Time	$T_{OFF}$		0.07	0.2	ms	$I_F = 5\text{mA}$ , $I_O = 50\text{mA}$ , $T_A = 25^{\circ}\text{C}$	
				0.5	ms	$I_F = 5\text{mA}$ , $I_O = 50\text{mA}$	
			0.07	0.2	ms	$I_F = 2\text{mA}$ , $I_O = 50\text{mA}$ , $T_A = 25^{\circ}\text{C}$	
				0.5	ms	$I_F = 2\text{mA}$ , $I_O = 50\text{mA}$	
Output Transient Rejection	$dV_O/dt$	1	7		$\text{kV}/\mu\text{s}$	$\Delta V_O = 250\text{V}$ , $T_A = 25^{\circ}\text{C}$	
Input-Output Transient Rejection	$dV_{I-O}/dt$	1	$\geq 10$		$\text{kV}/\mu\text{s}$	$\Delta V_{I-O} = 1000\text{V}$ , $T_A = 25^{\circ}\text{C}$	

### Notes:

- For or qualified device performance over temperature range, it is recommended to operate at  $I_F = 5\text{mA}$ .
- Device is considered as a two terminal device: pins 1, 2, 3 and 4 shorted together and pins 5, 6, 7 and 8 shorted together.
- The Input-Output Momentary Withstand Voltage is a dielectric voltage rating that should not be interpreted as an input-output continuous voltage rating. For the continuous voltage rating refer to the IEC/EN/DIN EN 60747-5-21 Insulation Characteristics Table (if applicable), your equipment level safety specification, or Avago Technologies Application Note 1074, "Optocoupler Input-Output Endurance Voltage."
- The PCB design and environmental conditions are taken into consideration when measuring the  $I_{O(OFF)}$  performance.
- During the pulsed  $R_{(ON)}$  measurement ( $I_O$  duration  $\leq 30\text{ms}$ ), ambient ( $T_A$ ) and case temperature ( $T_C$ ) are equal.

For product information and a complete list of distributors, please go to our web site: [www.avagotech.com](http://www.avagotech.com)

Avago, Avago Technologies, and the A logo are trademarks of Avago Technologies in the United States and other countries. Data subject to change. Copyright © 2005-2012 Avago Technologies. All rights reserved.  
AV02-0452EN - March 19, 2012

