



ELECTRONICS

Approval



TO :
DATE :

SAMSUNG TFT-LCD
MODEL NO : LTN156AT17-D

NOTE : Extension code [-0]
→ LTN156AT17-D
Surface type [Glare, True life]

The information described in this SPEC is preliminary and can be changed without prior notice.

APPROVED BY : _____

PREPARED BY : LCD Application Engineering Part 1

SAMSUNG ELECTRONICS CO., LTD.



Samsung Secret

Doc.No.	LTN156AT17-D	Rev.No	04-A00-S-110111	Page	1 / 32
---------	--------------	--------	-----------------	------	--------

GENERAL DESCRIPTION

DESCRIPTION

LTN156AT17-D is a color active matrix TFT (Thin Film Transistor) liquid crystal display (LCD) that uses amorphous silicon TFT as switching devices. This model is composed of a TFT LCD panel, a driver circuit and a backlight system. The resolution of a 15.6" contains 1366 x 768 pixels and can display up to 262,144 colors. 6 O'clock direction is the Optimum viewing angle.

FEATURES

- 1366 x 768 pixels resolution (16:9)
- Fast Response Time
- Low power consumption
- LED BLU Structure
- DE (Data enable) only mode
- 3.3V LVDS Interface
- On board EDID chip
- RoHS compliance
- PVC free compliance
- BFR free compliance
- As free compliance

APPLICATIONS

- Notebook PC
- If the usage of this product is not for PC application, but for others, please contact SEC

GENERAL INFORMATION

Item	Specification	Unit	Note
Display area	344.232 (H) x 193.536 (V) (15.6" diagonal)	mm	
Driver element	a-Si TFT active matrix		
Display colors	262,144		
Number of pixel	1366 x 768	pixel	16 : 9
Pixel arrangement	RGB vertical stripe		
Pixel pitch	0.252 (H) x 0.252 (V) (TYP.)	mm	
Display Mode	Normally white		
Surface treatment	Haze 0%, Hardness 3H		Glare

Samsung Secret

Mechanical Information

Item		Min.	Typ.	Max.	Unit	Note
Module size	Horizontal (H)	358.8	359.3	359.8	mm	
	Vertical (V)	209.0	209.5	210.0	mm	
	Depth (D)	-	-	5.5	mm	(1)
Weight		-	-	470	g	

Note (1) Measurement condition of outline dimension

- . Equipment : Vernier Calipers
- . Push Force : 500g · f (minimum)

1. ABSOLUTE MAXIMUM RATINGS

1.1 ENVIRONMENTAL ABSOLUTE RATINGS

Item	Symbol	Min.	Max.	Unit	Note
Storage temperate	TSTG	-20	60	°C	(1)
Operating temperate (Temperature of glass surface)	TOPR	0	50	°C	(1)
Shock (non-operating)	Snop	-	240	G	(2),(4)
Vibration (non-operating)	Vnop	-	2.41	G	(3),(4)

Note (1) Temperature and relative humidity range are shown in the figure below.

95 % RH Max. ($40\text{ °C} \geq T_a$)

Maximum wet - bulb temperature at 39 °C or less. ($T_a > 40\text{ °C}$) No condensation

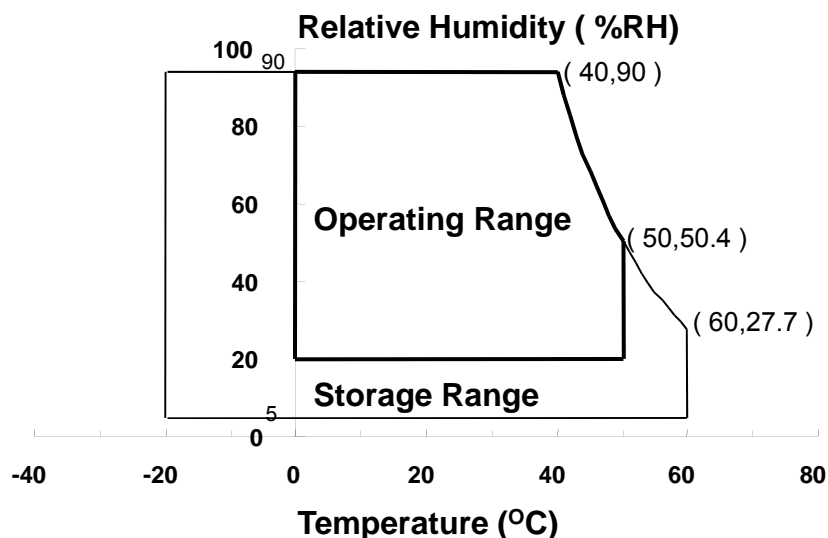

(2) 2ms, half sine wave, one time for $\pm X$, $\pm Y$, $\pm Z$.

(3) 5 - 500 Hz, random vibration, 30min for X, Y, Z.

(4) At testing Vibration and Shock, the fixture in holding the Module to be tested have to be hard and rigid enough so that the Module would not be twisted or bent by the fixture.

Samsung Secret

1.2 ELECTRICAL ABSOLUTE RATINGS

(1) TFT LCD MODULE

 $V_{DD} = 3.3V, V_{SS} = GND = 0V$

Item	Symbol	Min.	Max.	Unit	Note
Power Supply Voltage	V_{DD}	$V_{DD} - 0.3$	$V_{DD} + 0.3$	V	(1)
Logic Input Voltage	V_{DD}	$V_{DD} - 0.3$	$V_{DD} + 0.3$	V	(1)

Note (1) Within T_a ($25 \pm 2 \text{ }^\circ\text{C}$)

Samsung Secret

2. OPTICAL CHARACTERISTICS

The following items are measured under stable conditions. The optical characteristics should be measured in a dark room or equivalent state with the methods shown in Note (5).
Measuring equipment : TOPCON SR-3

* Ta = 25 ± 2 °C, V_{DD}=3.3V, f_v= 60Hz, f_{DCLK} = 76.69 MHz, I_L = 27 mA

Item	Symbol	Condition	Min.	Typ.	Max	Unit	Note	
Contrast Ratio (5 Points)	CR	Normal Viewing Angle φ = 0 θ = 0	500	-	-	-	(1), (2), (5)	
Response Time at Ta (Rising + Falling)	T _{RT}		-	16	25	msec	(1), (3)	
Average Luminance of White (5 Points)	Y _{L,AVE}		180	220	-	cd/m ²	I _L =27 mA (1), (4)	
Color Chromaticity (CIE)	Red		R _X	0.580	0.615	0.645	-	
			R _Y	0.327	0.355	0.385		
	Green		G _X	0.305	0.335	0.365		
			G _Y	0.580	0.610	0.640		
	Blue		B _X	0.120	0.150	0.180		
			B _Y	0.070	0.100	0.130		
	White		W _X	0.283	0.313	0.343		
		W _Y	0.299	0.329	0.359			
Viewing Angle	Hor.	θ _L	40	-	-	Degrees	(1), (5) SR-3	
		θ _R	40	-	-			
	Ver.	φ _H	10	-	-			
		φ _L	30	-	-			
Color Gamut			-	60	-	%		
13 Points White Variation	δ _L		-	-	1.7	-	(6)	

Samsung Secret

Note 1) Definition of Viewing Angle : Viewing angle range($10 \leq C/R$)

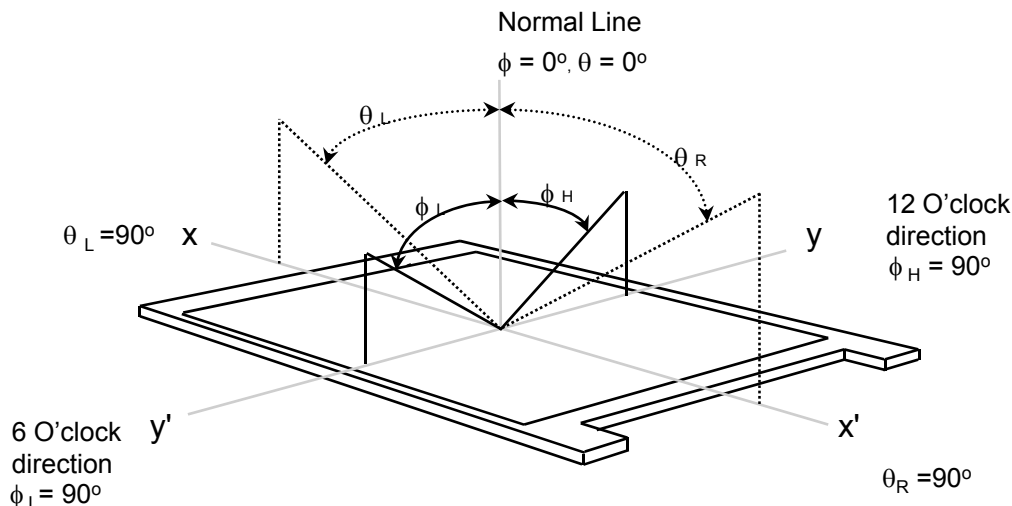

Note 2) Definition of Contrast Ratio (CR) : Ratio of gray max (Gmax) ,gray min (Gmin) at 5 points (33, 55, 77, 37, 73)

$$CR = \frac{CR(33) + CR(55) + CR(77) + CR(37) + CR(73)}{5}$$

Points : 33, 55, 77, 37, 73 at the figure of Note (6).

Note 3) Definition of Response time :

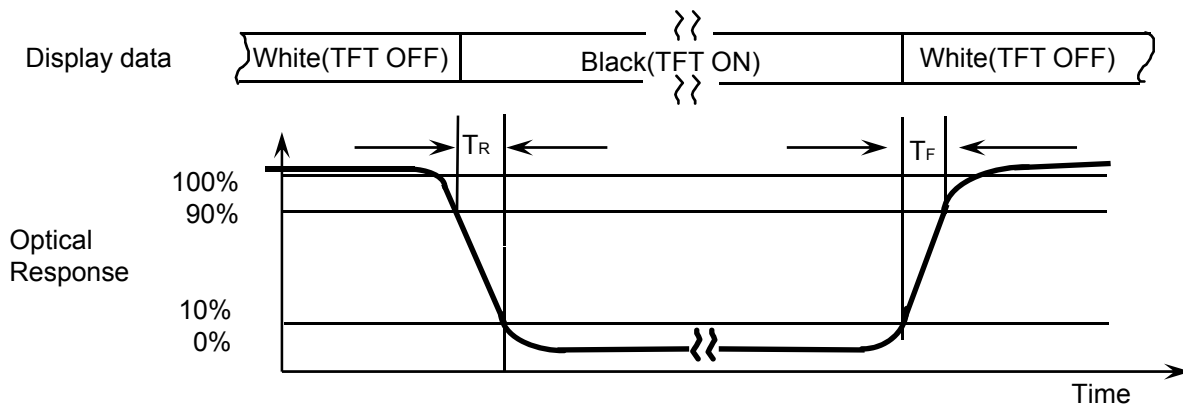

Note 4) Definition of Average Luminance of White : measure the luminance of white at 5 points.

Average Luminance of White ($Y_{L,AVE}$)

$$Y_{L,AVE} = \frac{Y_{L33} + Y_{L55} + Y_{L77} + Y_{L37} + Y_{L73}}{5}$$

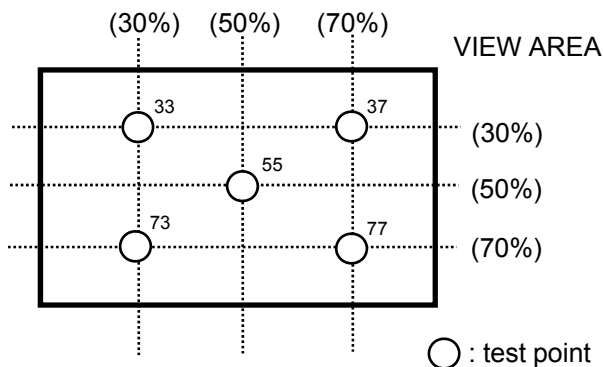

Note 5) After stabilizing and leaving the panel alone at a given temperature for 30 min , the measurement should be executed. Measurement should be executed in a stable, windless, and dark room. 30 min after lighting the backlight. This should be measured in the center of screen.

LED current : 27 mA

Environment condition : $T_a = 25 \pm 2 \text{ }^\circ\text{C}$

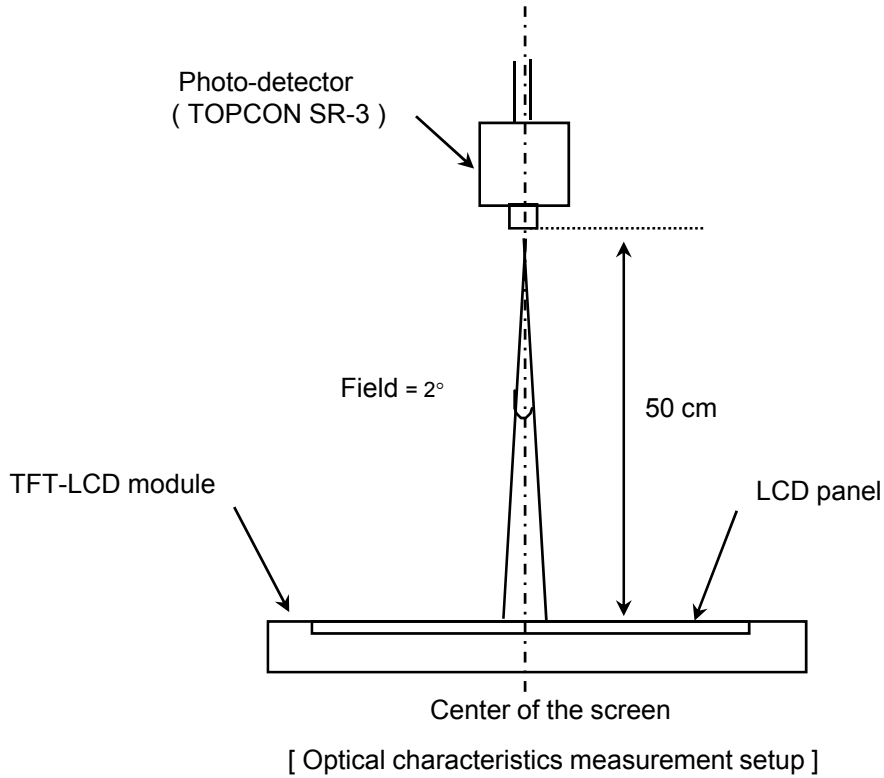

Note 6) Definition of 13 points white variation (δL), [11 ~ 99]

$$\delta L = \frac{\text{Maximum luminance of 13 points}}{\text{Minimum luminance of 13 points}}$$

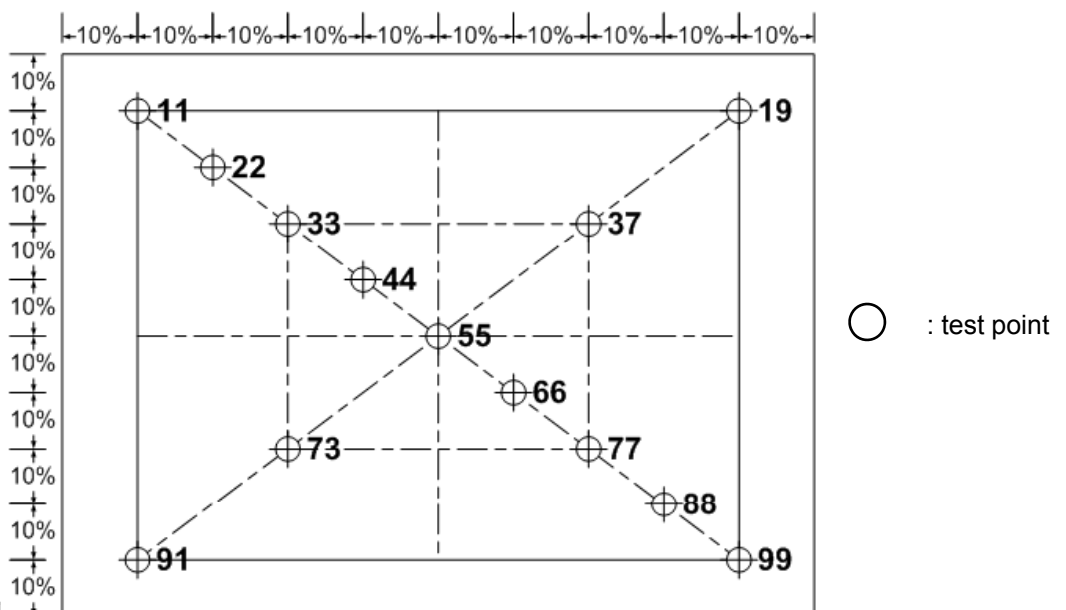

Samsung Secret

3. ELECTRICAL CHARACTERISTICS

3.1 TFT LCD MODULE

 $T_a = 25 \pm 2^\circ\text{C}$

Item	Symbol	Min.	Typ.	Max.	Unit	Note	
Voltage of Power Supply	V_{DD}	3.0	3.3	3.6	V		
Differential Input Voltage for LVDS Receiver Threshold	High	V_{IH}	-	-	+100	mV	$V_{CM} = +1.2V$
	Low	V_{IL}	-100	-	-	mV	
Vsync Frequency	f_V	-	60	-	Hz		
Hsync Frequency	f_H	-	97.08	-	KHz		
Main Frequency	f_{DCLK}	-	76.69	-	MHz		
Rush Current	I_{RUSH}	-	-	1.5	A	(4)	
Current of Power Supply	White	I_{DD}	-	250	-	mA	(2),(3)*a
	Mosaic		-	370	424	mA	(2),(3)*b

Note (1) Display data pins and timing signal pins should be connected. (GND = 0V)

(2) $f_V = 60\text{Hz}$, $f_{DCLK} = 76.69\text{ MHz}$, $V_{DD} = 3.3V$, DC Current.

(3) Power dissipation pattern

*a) White Pattern

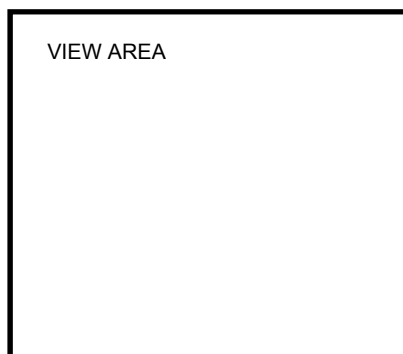

*b) Mosaic Pattern

Display Brightest Gray Level →

Display Darkest Gray Level →

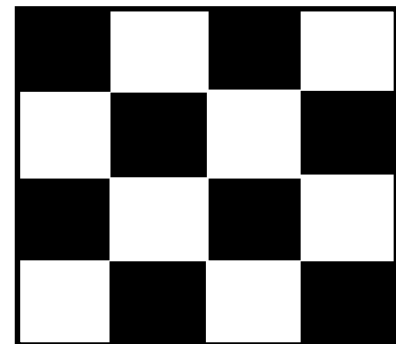

Samsung Secret

4) Rush current measurement condition

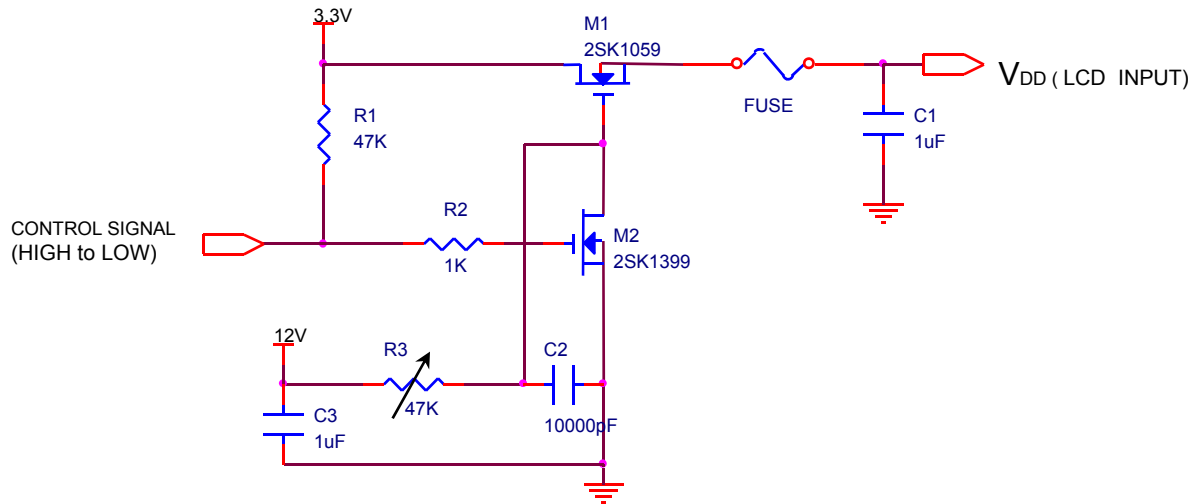

V_{DD} rising time is 470us

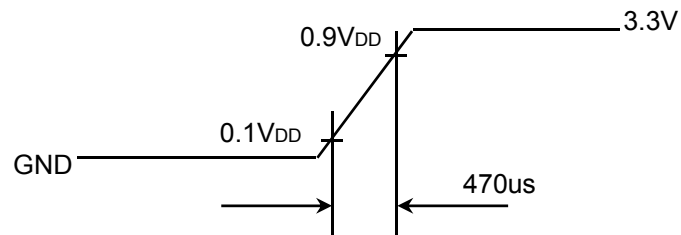

3.2 BACK-LIGHT UNIT

Ta= 25 ± 2 °C

Item	Symbol	Min.	Typ.	Max.	Unit	Note
LED Forward Current	IF	-	20	-	mA	
LED Forward Voltage	VF	3.0	-	3.4	V	
LED Array Voltage	VP	24	-	27.2	V	VF X 9 LEDs
Power Consumption	P	-	-	4.5	W	IF X VF X 36 LEDs (w/o Converter)

3.3 LED Driver

- LED Driver Manufacturer : Richtek

Ta= 25 ± 2 °C

Item	Symbol	Min.	Typ.	Max.	Unit	Note
Input Voltage	V _{in}	6	12	24	V	
Input Current	I	-	108	-	mA	Max.MOSFET curent in PM6600
Output PWM Frequency	F _{PWM}	500	-	2000	kHz	No output PWM
Burst Ratio	D	10	-	100	%	PWM freq : 200Hz~10KHz
External PWM Dimming Control Frequency (BLIM)	F _{BLIM}	200Hz	-	10KHz	kHz	BLIM=PWM 0V~3.3V
Output Power	P _{out}	-	-	2.3	W	BLIM=100%

Note - Test Equipment : Fluke 45

Samsung Secret

4. BLOCK DIAGRAM

4.1 TFT LCD Module

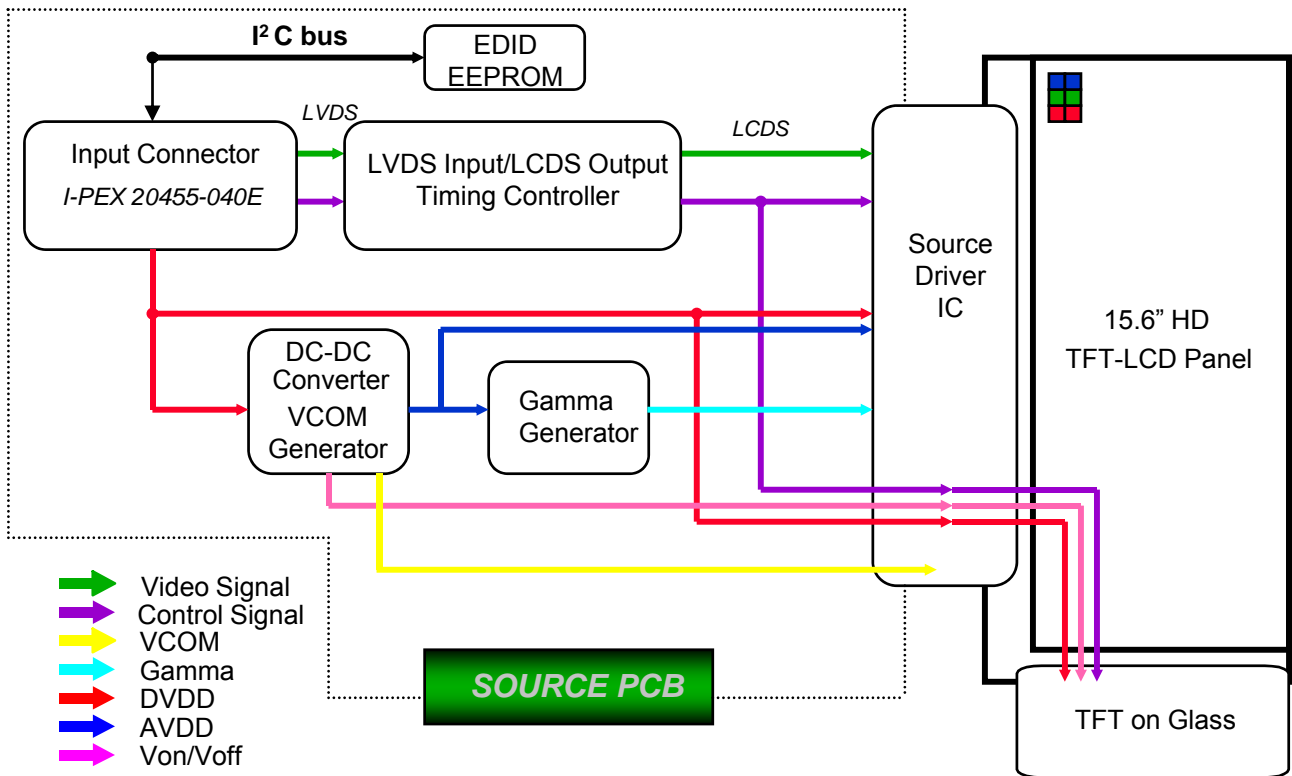

Samsung Secret

4. BLOCK DIAGRAM

4.2 LED connection and placement

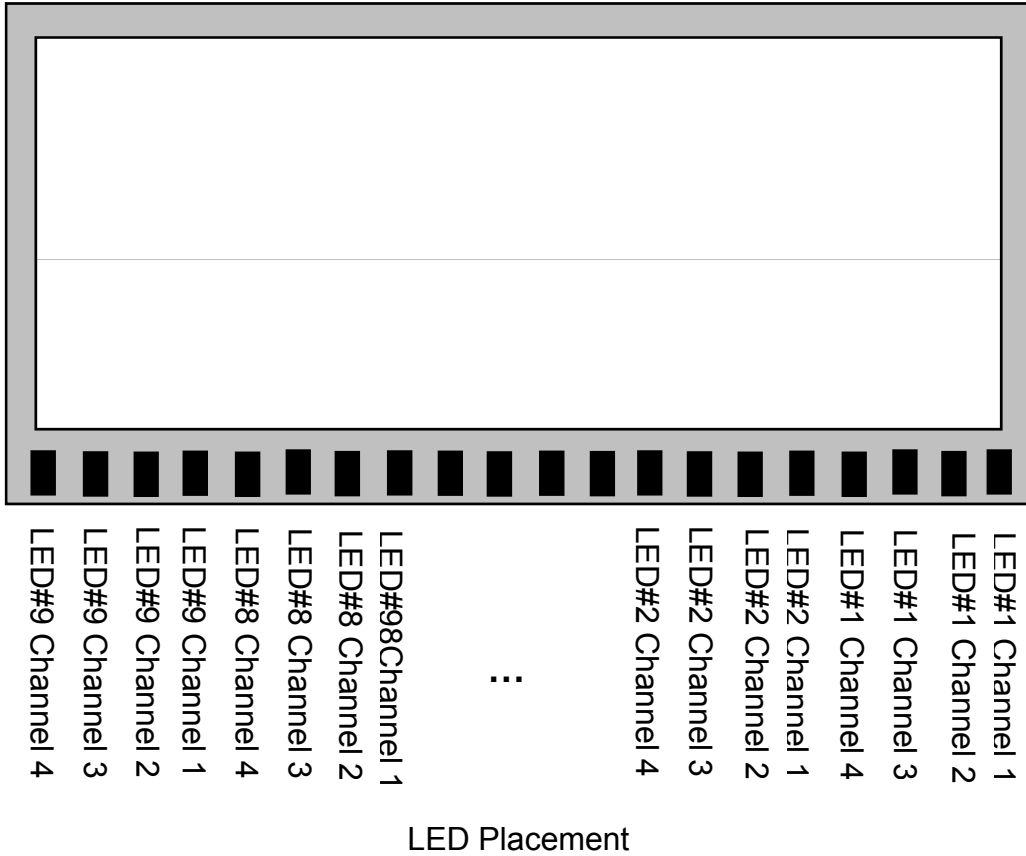
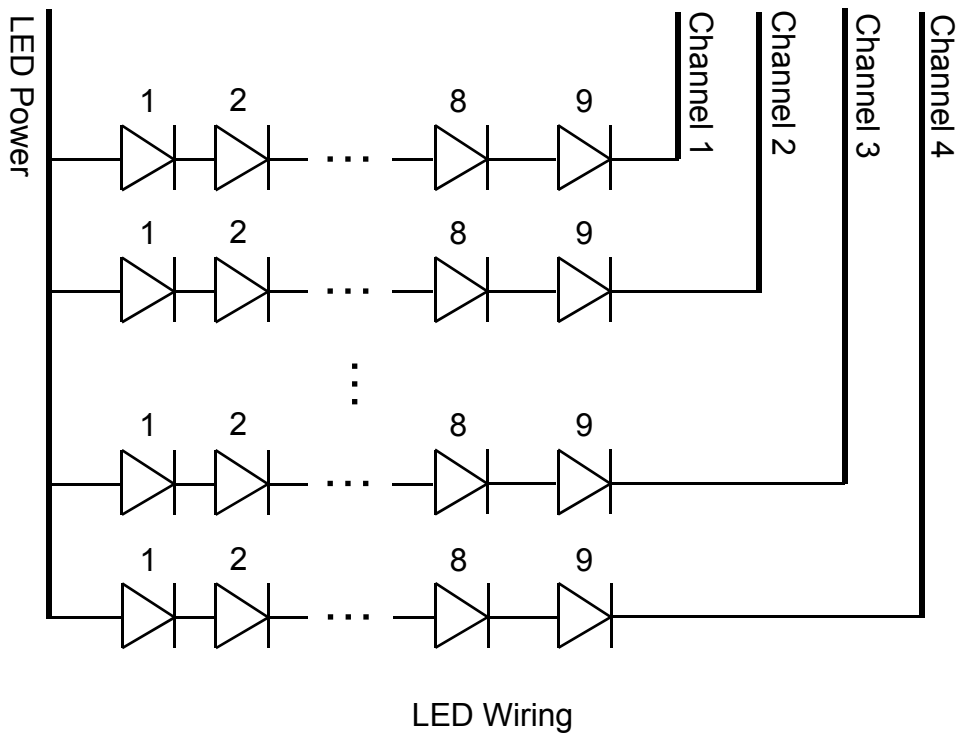

Samsung Secret

5. INPUT TERMINAL PIN ASSIGNMENT

5.1. Input Signal & Power (LVDS, Connector : I-PEX 20455-040E)

PIN #	Symbol	Description
1	NC	No connection
2	VDD	Power Supply, 3.3 V (typical)
3	VDD	Power Supply, 3.3 V (typical)
4	V EEDID	DDC 3.3V power
5	TEST	Panel Self Test
6	Clk EEDID	DDC Clock
7	DATA EEDID	DDC Data
8	Odd_Rin0-	- LVDS differential data input (R0-R5, G0) (odd pixels)
9	Odd_Rin0+	+ LVDS differential data input (R0-R5, G0) (odd pixels)
10	VSS	Ground – Shield
11	Odd_Rin1-	- LVDS differential data input (G1-G5, B0-B1) (odd pixels)
12	Odd_Rin1+	+ LVDS differential data input (G1-G5, B0-B1) (odd pixels)
13	VSS	Ground – Shield
14	Odd_Rin2-	- LVDS differential data input (B2-B5, HS, VS, DE) (odd pixels)
15	Odd_Rin2+	+ LVDS differential data input (B2-B5, HS, VS, DE) (odd pixels)
16	VSS	Ground – Shield
17	Odd_ClkIN-	- LVDS differential clock input (odd pixels)
18	Odd_ClkIN+	+ LVDS differential clock input (odd pixels)
19	NC	No connection
20	NC	No connection
21	NC	No connection
22	NC	No connection
23	NC	No connection
24	NC	No connection
25	NC	No connection

Samsung Secret

5. INPUT TERMINAL PIN ASSIGNMENT

5.1. Input Signal & Power (LVDS, Connector : I-PEX 20455-040E)

PIN #	Symbol	Description
26	NC	No connection
27	NC	No connection
28	NC	No connection
29	NC	No connection
30	NC	No connection
31	VSSLED	Ground – LED
32	VSSLED	Ground – LED
33	VSSLED	Ground – LED
34	NC	No connection
35	PWM	System PWM Signal Input (+3.3V Swing)
36	LED_EN	LED enable pin (+3.3V Input)
37	NC	NC
38	VDDLED	7.5V – 21V LED power
39	VDDLED	7.5V – 21V LED power
40	VDDLED	7.5V – 21V LED power

Samsung Secret

5.2 LVDS Interface : Transmitter DS90CF363 or Compatible

Pin No.	Name	RGB Signal	Pin No.	Name	RGB Signal
51	TxIN0	R0	14	TxIN14	G5
52	TxIN1	R1	15	TxIN15	B0
54	TxIN2	R2	19	TxIN18	B1
55	TxIN3	R3	20	TxIN19	B2
56	TxIN4	R4	22	TxIN20	B3
3	TxIN6	R5	23	TxIN21	B4
4	TxIN7	G0	24	TxIN22	B5
6	TxIN8	G1	27	TxIN24	Hsync
7	TxIN9	G2	28	TxIN25	Vsync
11	TxIN12	G3	30	TxIN26	DE
12	TxIN13	G4	31	TxCLKIN	Clock

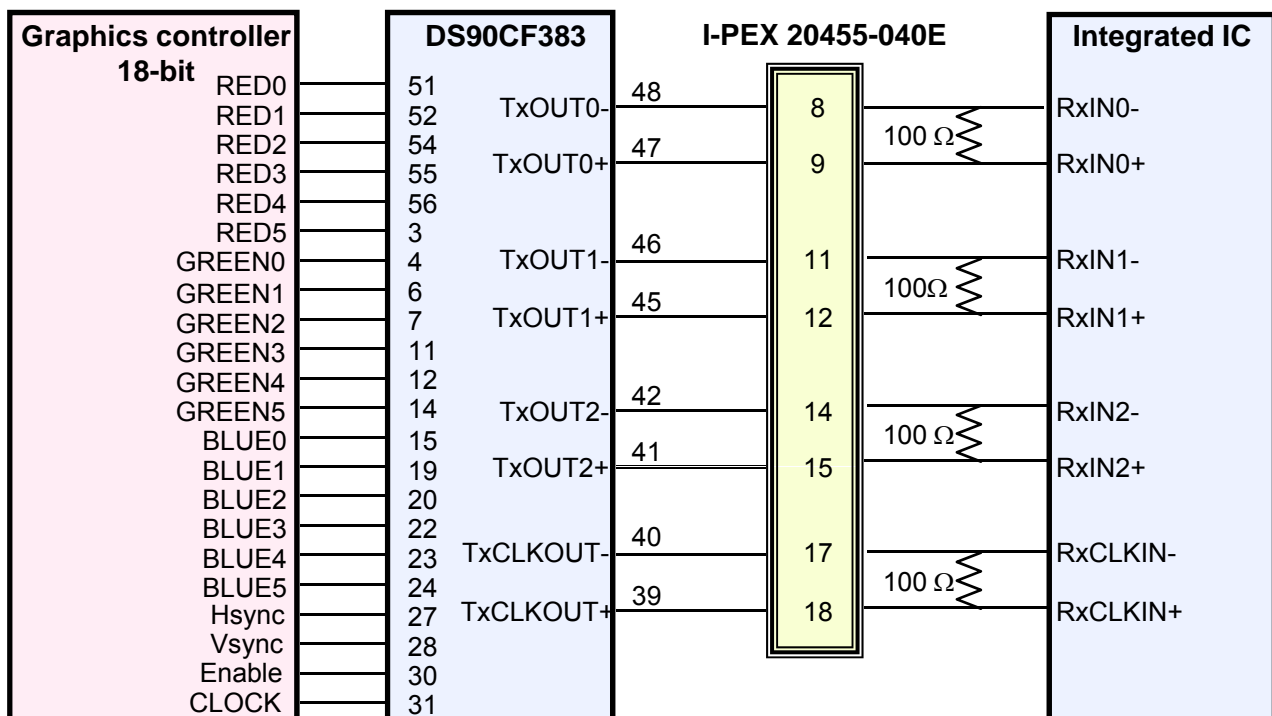
LVDS INTERFACE

Note : The LCD Module uses a 100ohm resistor between positive and negative lines of each receiver input.

Samsung Secret

5.3 Timing Diagrams of LVDS For Transmission

LVDS Receiver : Integrated T-CON

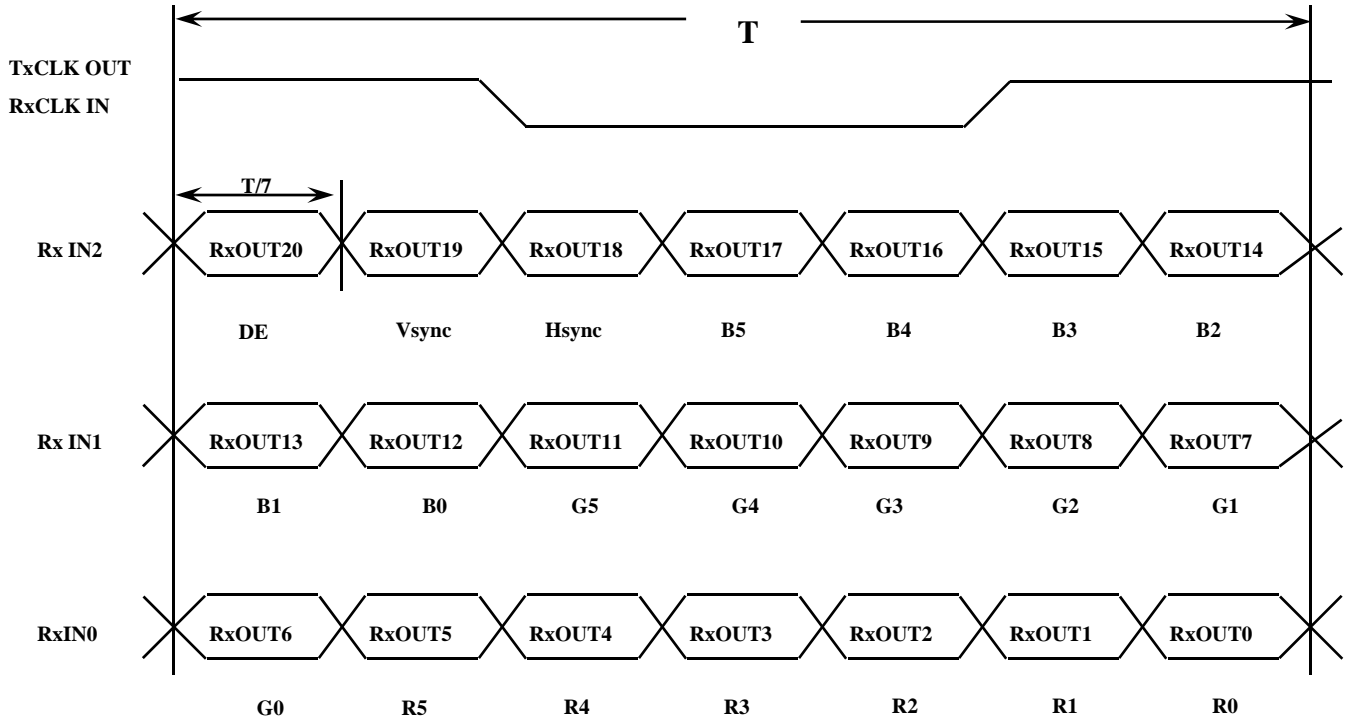

Samsung Secret

5.4 Input Signals, Basic Display Colors and Gray Scale of Each Color

Color	Display	Data Signal																Gray Scale Level	
		Red					Green					Blue							
		R0	R1	R2	R3	R4	R5	G0	G1	G2	G3	G4	G5	B0	B1	B2	B3		45
Basic Colors	Black	0	0	0	0	0	0	0	0	0	0	0	0	0	0	0	0	0	-
	Blue	0	0	0	0	0	0	0	0	0	0	0	0	1	1	1	1	1	-
	Green	0	0	0	0	0	0	1	1	1	1	1	1	0	0	0	0	0	-
	Cyan	0	0	0	0	0	0	1	1	1	1	1	1	1	1	1	1	1	-
	Red	1	1	1	1	1	1	0	0	0	0	0	0	0	0	0	0	0	-
	Magenta	1	1	1	1	1	1	0	0	0	0	0	0	1	1	1	1	1	-
	Yellow	1	1	1	1	1	1	1	1	1	1	1	1	0	0	0	0	0	-
	White	1	1	1	1	1	1	1	1	1	1	1	1	1	1	1	1	1	-
Gray Scale Of Red	Black	0	0	0	0	0	0	0	0	0	0	0	0	0	0	0	0	0	R0
	Dark	1	0	0	0	0	0	0	0	0	0	0	0	0	0	0	0	0	R1
	↑	0	1	0	0	0	0	0	0	0	0	0	0	0	0	0	0	0	R2
	:	:	:	:	:	:	:	:	:	:	:	:	:	:	:	:	:	:	R3~R60
	:	:	:	:	:	:	:	:	:	:	:	:	:	:	:	:	:	:	
	↓	1	0	1	1	1	1	0	0	0	0	0	0	0	0	0	0	0	R61
	Light	0	1	1	1	1	1	0	0	0	0	0	0	0	0	0	0	0	R62
	Red	1	1	1	1	1	1	0	0	0	0	0	0	0	0	0	0	0	R63
Gray Scale Of Green	Black	0	0	0	0	0	0	0	0	0	0	0	0	0	0	0	0	0	G0
	Dark	0	0	0	0	0	0	1	0	0	0	0	0	0	0	0	0	0	G1
	↑	0	0	0	0	0	0	0	1	0	0	0	0	0	0	0	0	0	G2
	:	:	:	:	:	:	:	:	:	:	:	:	:	:	:	:	:	:	G3~G60
	:	:	:	:	:	:	:	:	:	:	:	:	:	:	:	:	:	:	
	↓	0	0	0	0	0	0	1	0	1	1	1	1	0	0	0	0	0	G61
	Light	0	0	0	0	0	0	0	1	1	1	1	1	0	0	0	0	0	G62
	Green	0	0	0	0	0	0	1	1	1	1	1	1	0	0	0	0	0	G63
Gray Scale Of Blue	Black	0	0	0	0	0	0	0	0	0	0	0	0	0	0	0	0	0	B0
	Dark	0	0	0	0	0	0	0	0	0	0	0	0	1	0	0	0	0	B1
	↑	0	0	0	0	0	0	0	0	0	0	0	0	0	1	0	0	0	B2
	:	:	:	:	:	:	:	:	:	:	:	:	:	:	:	:	:	:	B3~B60
	:	:	:	:	:	:	:	:	:	:	:	:	:	:	:	:	:	:	
	↓	0	0	0	0	0	0	0	0	0	0	0	0	1	0	1	1	1	B61
	Light	0	0	0	0	0	0	0	0	0	0	0	0	0	1	1	1	1	B62
	Blue	0	0	0	0	0	0	0	0	0	0	0	0	1	1	1	1	1	B63

Note 1) Definition of gray :

Rn: Red gray, Gn: Green gray, Bn: Blue gray (n=gray level)

Note 2) Input signal: 0 =Low level voltage, 1=High level voltage

Samsung Secret

5.5 Pixel Format in the display

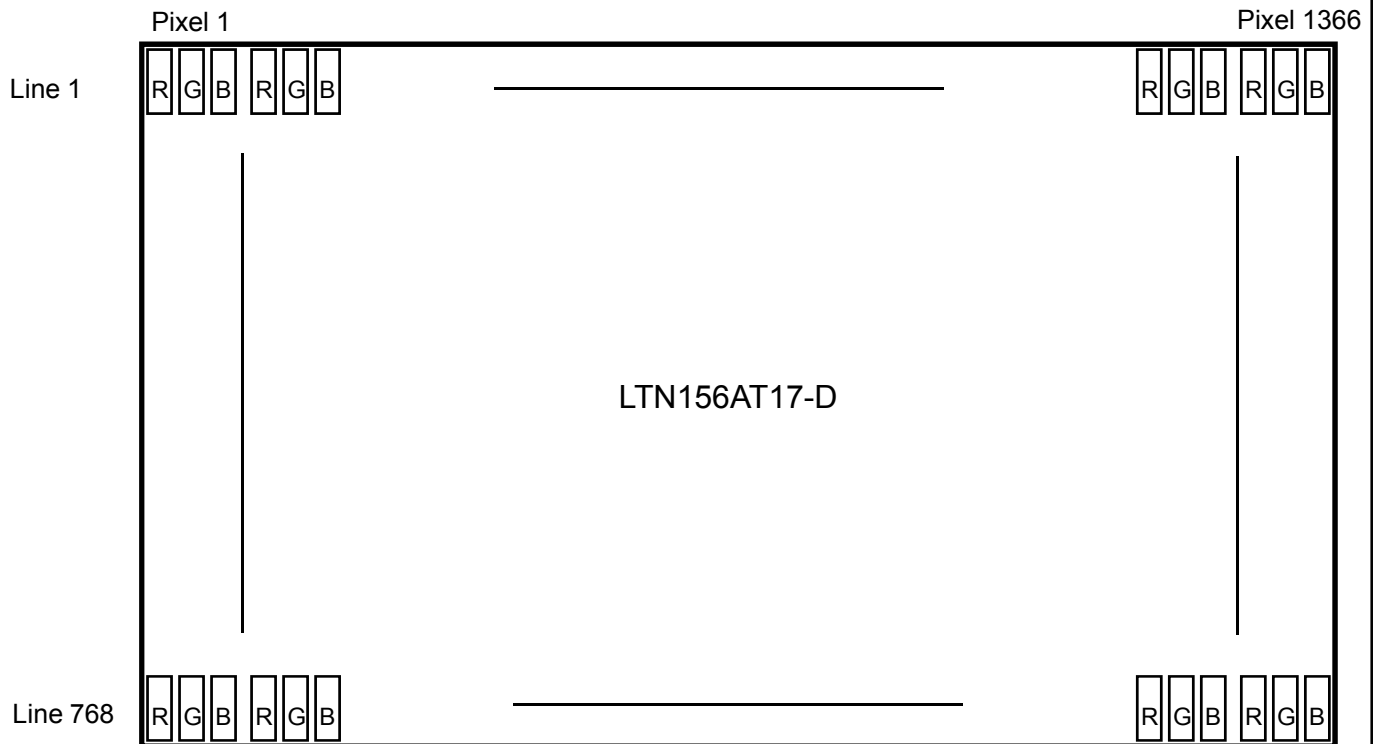

Samsung Secret

6. INTERFACE TIMING

6.1 Timing Parameters

Signal	Item	Symbol	Min.	Typ.	Max.	Unit	Note
Frame Frequency	Cycle	TV	-	790	-	Lines	-
Vertical Active Display Term	Display Period	TVD	-	768	-	Lines	-
One Line Scanning Time	Cycle	TH	-	1586	-	Clocks	-
Horizontal Active Display Term	Display Period	THD	-	1366	-	Clocks	-

6.2 Timing diagrams of interface signal

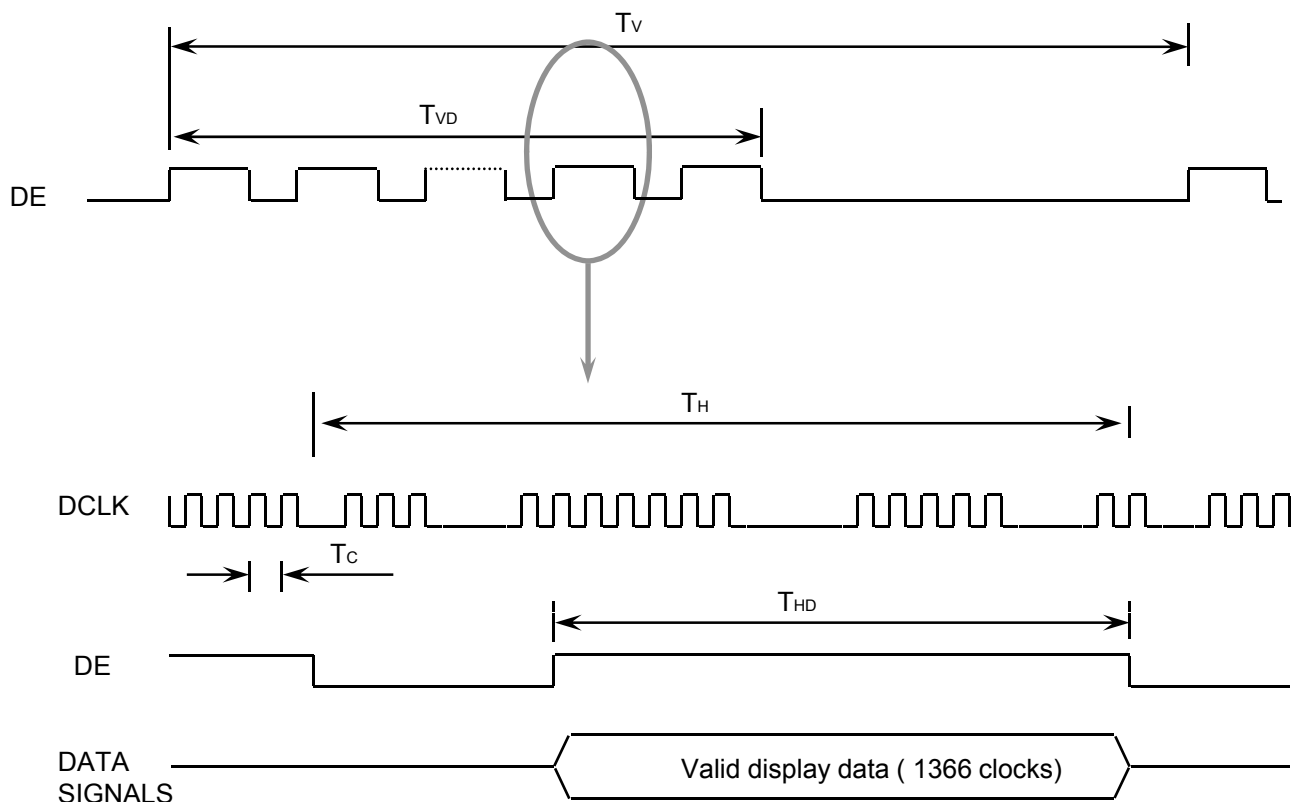

Samsung Secret

6.3 Power ON/OFF Sequence

: To prevent a latch-up or DC operation of the LCD module, the power on/off sequence should be as the diagram below.

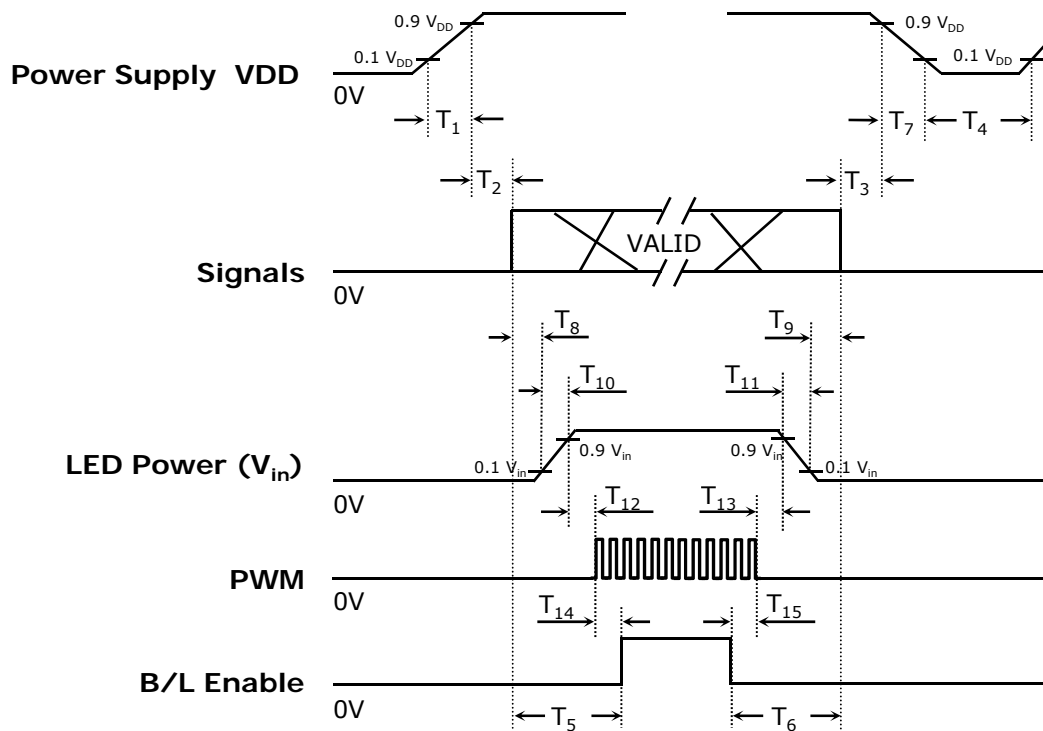

Timing (ms)	Remarks
$0.5 < T_1 \leq 10$	V_{DD} rising time from 10% to 90%
$0 < T_2 \leq 50$	Delay from V_{DD} to valid data at power ON
$0 < T_3 \leq 50$	Delay from valid data OFF to V_{DD} OFF at power Off
$500 \leq T_4$	V_{DD} OFF time for Windows restart
$200 \leq T_5$	Delay from valid data to B/L enable at power ON
$200 \leq T_6$	Delay from valid data off to B/L disable at power Off
$0 < T_7 \leq 10$	V_{DD} falling time from 90% to 10%
$10 < T_8$	Delay from valid data on to LED driver V_{in} rising time 10%
$10 < T_9$	Delay from LED driver V_{in} falling time 10% to valid data Off
$0.5 < T_{10} \leq 10$	LED V_{in} rising time from 10% to 90%
$0.5 < T_{11} \leq 10$	LED V_{in} falling time from 90% to 10%
$10 < T_{12}$	Delay from LED driver V_{in} rising time 90% to PWM ON
$10 < T_{13}$	Delay from PWM Off to LED driver V_{in} falling time 10%
$10 < T_{14}$	Delay from PWM ON to B/L Enable ON
$10 < T_{15}$	Delay from B/L Enable Off to PWM Off

Note : Backlight may flash if interface signal remains floating state at invalid period.

7. MECHANICAL OUTLINE DIMENSION

Approval

It will be attached with PDF file

Samsung Secret

Doc.No.	LTN156AT17-D	Rev.No	04-A00-S-110111	Page	23 / 32
----------------	--------------	---------------	-----------------	-------------	---------

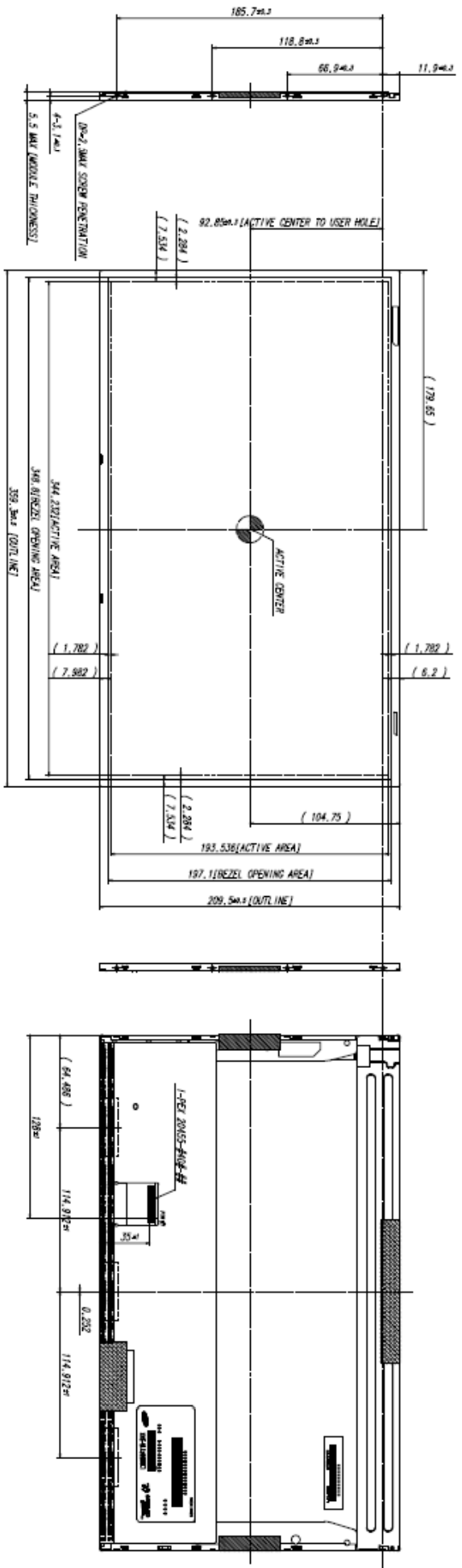

<INNER HOLE SCREW HOLE DEPTH>

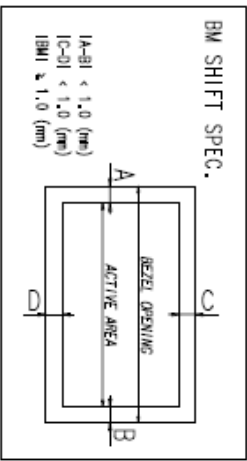

BM SHIFT SPEC.
 (A-B) < 1.0 (mm)
 (C-D) < 1.0 (mm)
 (B-A) > 1.0 (mm)

- * NOTE
1. SIGNAL INTERFACE CONNECTOR TO BE SPECIFIED AS BELOW.
 - I. WAYER : I-CONNECT except compatible connector basically.
 - II. INPUT CONNECTOR : I-PEZ 20155-040E-12
 2. LED CONNECTOR FOR BACKLIGHT TO BE SPECIFIED AS BELOW.
 - I. WAYER : OUV Electronics
 - II. PART NO. : 51441-1041
 3. CALIBERS MEASURING FORCE : 750 x 250 gf/cm
 4. MAXIMUM SCREW TORQUE : MAX 2.5 kgf-cm(21.6gf-cm)
 5. WEIGHT : 465 g MAX
 6. IN ORDER TO AVOID IC DAMAGE, IT IS NOT ALLOW THAT OVERLAPPING OF CABLES OR ANTENNAS, CAMERA, WLAN, MMW, OVER THESE OFF LOCATIONS.

NO.	REV.	DESCRIPTION	DATE
1	1	INITIAL DRAWING	2015.04.10
2	2	REVISION	2015.04.10
3	3	REVISION	2015.04.10
4	4	REVISION	2015.04.10
5	5	REVISION	2015.04.10
6	6	REVISION	2015.04.10
7	7	REVISION	2015.04.10
8	8	REVISION	2015.04.10
9	9	REVISION	2015.04.10
10	10	REVISION	2015.04.10

8. PACKING**1. CARTON(Internal Package)****(1) Packing Form**

Corrugated Cardboard box and Corrupad form as shock absorber

(2) Packing Method

CUSHION BOTTOM

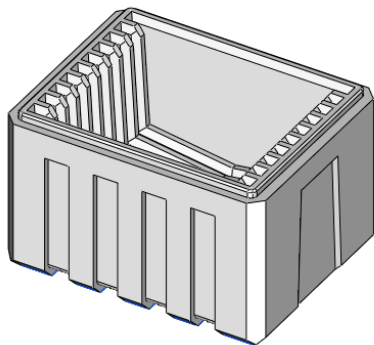

PANEL : 2EA/SLIT

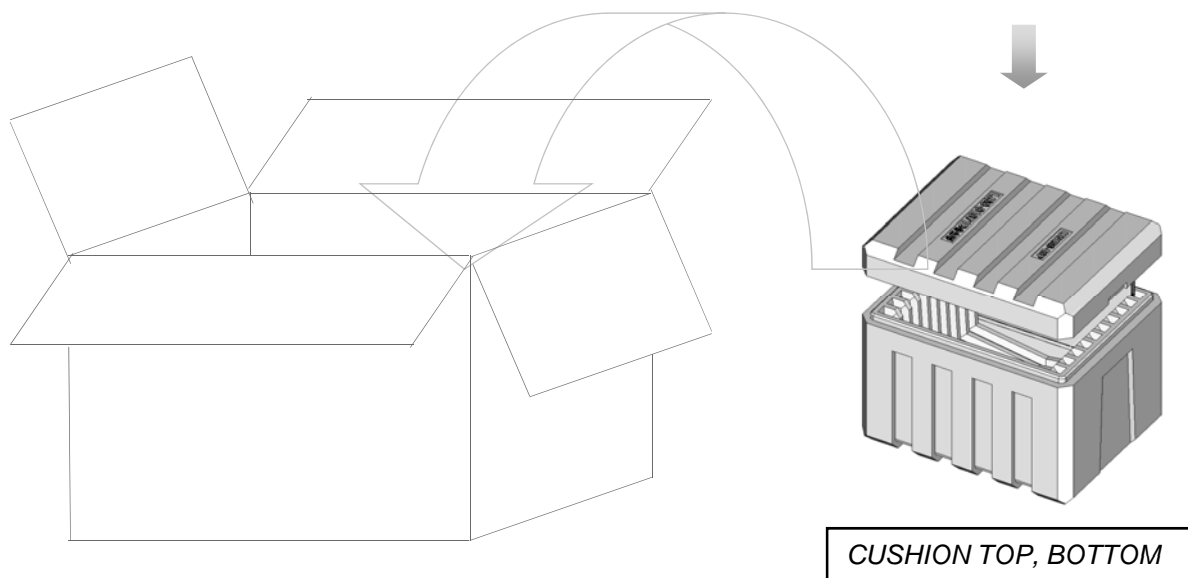
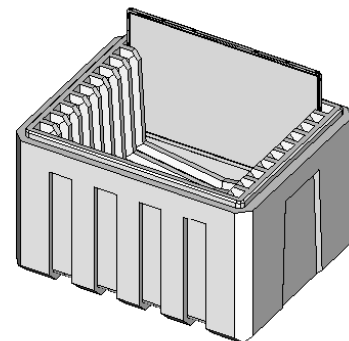

Note (1) Total : Approx. 12400 g

(2) Acceptance number of piling : 20 sets

(3) Carton size : 359(W) X 463(D) X 333(H)

(4) MAX accumulation quantity : 5 cartons

Samsung Secret

No	Part name	Quantity
1	Static electric protective sack	20
2	Packing case (Inner box) included shock absorber	1 set
3	Pictorial marking	2 pcs
4	Carton	1 set

9. MARKINGS & OTHERS

A nameplate bearing followed by is affixed to a shipped product at the specified location on each product.

(1) Parts number : LTNXXXXXXXX-XXX

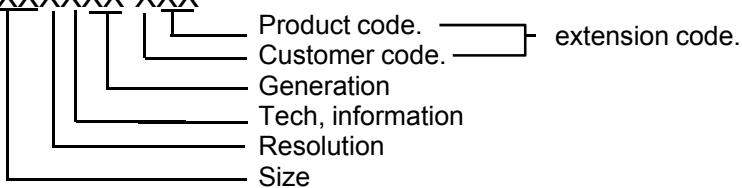

(2) Revision : Three letters

(3) Lot number : X Y 7 A XXX XX X

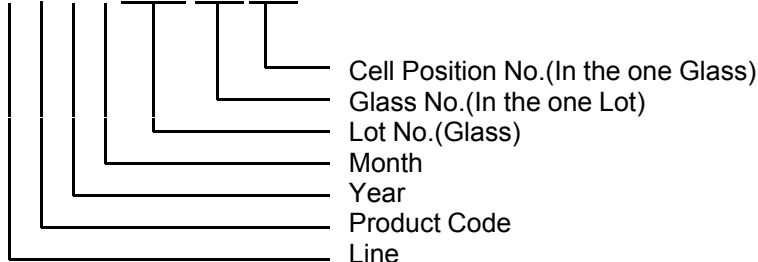

(4) Nameplate Indication(Following example is only for reference)

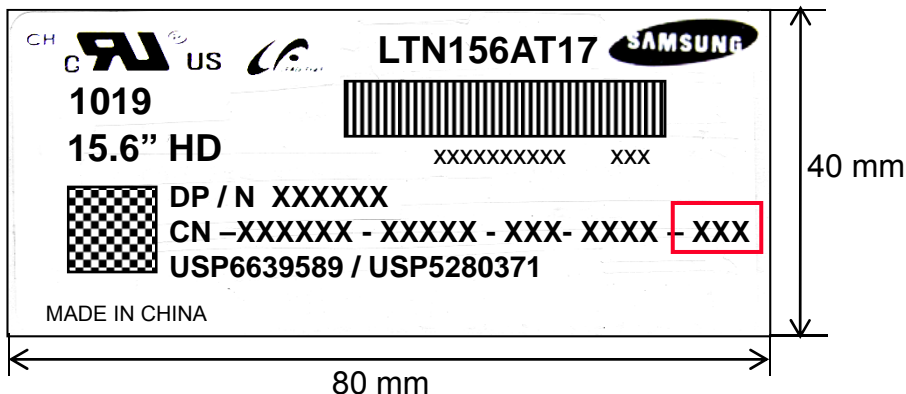





Parts name : LTN156AT17
Lot number : xxxxxxxxxxxx
Inspected work week : 1019 Number (2010 year 19th week)

Samsung Secret

※ Panel revision code scheme (Refer to the Red box on the label)

Build Name(s)	Revision Code(s)
SST (WS)	X00, X01, X02, ... X09
PT (ES)	X10, X11, X12, ... X19
ST (CS)	X20, X21, X23, ... X29
XB (MP)	A00, A01, A02, ... A99

(5) Packing small box attach (Following example is only for reference)

SAMSUNG Elec CHEONAN CITY, CHUNGCHONGNAM-DO KOREA		LTNXXXXXXXX-XXX	 <div style="border: 1px solid red; padding: 2px; display: inline-block;">REV.xxx</div>
DP/N			Vendor ID/Loc : 21320/39792
Box Qty 20	C/O-KR		 Vendor Id/Loc: 39792/39792

04Y4GM : DELL P/N

Samsung Secret

10. GENERAL PRECAUTIONS

Approval

1. Handling

- (a) When the module is assembled, It should be attached to the system firmly using every mounting holes. Be careful not to twist and bend the modules.
- (b) Refrain from strong mechanical shock and / or any force to the module. In addition to damage, this may cause improper operation or damage to the module.
- (c) Note that polarizers are very fragile and could be easily damaged. Do not press or scratch the surface harder than a HB pencil lead.
- (d) Wipe off water droplets or oil immediately. If you leave the droplets for a long time, Staining and discoloration may occur.
- (e) If the surface of the polarizer is dirty, clean it using some absorbent cotton or soft cloth.
- (f) The desirable cleaners are water, IPA (Isopropyl Alcohol) or Hexane. Do not use Ketone type materials(ex. Acetone), Ethyl alcohol, Toluene, Ethyl acid or Methyl chloride. It might permanent damage to the polarizer due to chemical reaction.
- (g) If the liquid crystal material leaks from the panel, it should be kept away from the eyes or mouth. In case of contact with hands, legs or clothes, it must be washed away thoroughly with soap.
- (h) Protect the module from static, it may cause damage to the C-MOS Gate Array IC.
- (i) Use fingerstalls with soft gloves in order to keep display clean during the incoming inspection and assembly process.
- (j) Do not disassemble the module.
- (k) Do not pull or fold the lamp wire.
- (l) Do not adjust the variable resistor which is located on the back side.
- (m) Protection film for polarizer on the module shall be slowly peeled off just before use so that the electrostatic charge can be minimized.
- (n) Pins of I/F connector shall not be touched directly with bare hands.

Samsung Secret

Doc.No.	LTN156AT17-D	Rev.No	04-A00-S-110111	Page	28 / 32
----------------	--------------	---------------	-----------------	-------------	---------

2. STORAGE

- (a) Do not leave the module in high temperature, and high humidity for a long time.
It is highly recommended to store the module with temperature from 0 to 35 °C and relative humidity of less than 70%.
- (b) Do not store the TFT-LCD module in direct sunlight.
- (c) The module shall be stored in a dark place. It is prohibited to apply sunlight or fluorescent light during the store.

3. OPERATION

- (a) Do not connect, disconnect the module in the “ Power On” condition.
- (b) Power supply should always be turned on/off by following item 6.3
“ Power on/off sequence “.
- (c) Module has high frequency circuits. Sufficient suppression to the electromagnetic interference shall be done by system manufacturers. Grounding and shielding methods may be important to minimize the interference.
- (d) The standard limited warranty is only applicable when the module is used for general notebook applications. If used for purposes other than as specified, SEC is not to be held reliable for the defective operations. It is strongly recommended to contact SEC to find out fitness for a particular purpose.

4. OTHERS

- (a) Ultra-violet ray filter is necessary for outdoor operation.
- (b) Avoid condensation of water. It may result in improper operation or disconnection of electrode.
- (c) Do not exceed the absolute maximum rating value. (the supply voltage variation, input voltage variation, variation in part contents and environmental temperature, so on)
Otherwise the module may be damaged.
- (d) If the module displays the same pattern continuously for a long period of time, it can be the situation when the image “sticks” to the screen.
- (e) This module has its circuitry PCB's on the rear side and should be handled carefully in order not to be stressed.

Samsung Secret

11. EDID

Approval

	Byte	Field Name and Comments	Value	Value
	(hex)		(hex)	(binary)
Header	0	Header	00	00000000
	1	Header	FF	11111111
	2	Header	FF	11111111
	3	Header	FF	11111111
	4	Header	FF	11111111
	5	Header	FF	11111111
	6	Header	FF	11111111
	7	Header	00	00000000
Vendor / Product EDID Version	8	EISA manufacture code = 3 Character ID	4C	01001100
	9	EISA manufacture code (Compressed ASCII)	A3	10100011
	0A	Panel Supplier Reserved – Product Code	41	01000001
	0B	Panel Supplier Reserved – Product Code	54	01010100
	0C	LCD module Serial No - Preferred but Optional (“0” if not used)	00	00000000
	0D	LCD module Serial No - Preferred but Optional (“0” if not used)	00	00000000
	0E	LCD module Serial No - Preferred but Optional (“0” if not used)	00	00000000
	0F	LCD module Serial No - Preferred but Optional (“0” if not used)	00	00000000
	10	Week of manufacture	00	00000000
	11	Year of manufacture	14	00010100
	12	EDID structure version # = 1	01	00000001
	13	EDID revision #	04	00000100
	Display Parameters	14	Video I/P definition = Digital I/P	90
15		Max H image size = (Rounded to cm)	22	00100010
16		Max V image size = (Rounded to cm)	13	00010011
17		Display gamma = (gamma ×100)-100 = Example: (2.2×100) – 100 = 120	78	01111000
18		Feature support (DPM (Standby, Suspend, Active), Color Type, Other Feature)	0A	00001010
Panel Color Coordinates	19	Red/Green Low bit (RxRy/GxGy)	C8	11001000
	1A	Blue/White Low bit (BxBy/WxWy)	95	10010101
	1B	Red X Rx = 0.xxx	9E	10011110
	1C	Red Y Ry = 0.xxx	57	01010111
	1D	Green X Gx = 0.xxx	54	01010100
	1E	Green Y Gy = 0.xxx	92	10010010
	1F	Blue X Bx = 0.xxx	26	00100110
	20	Blue Y By = 0.xxx	0F	00001111
	21	White X Wx = 0.xxx	50	01010000
	22	White Y Wy = 0.xxx	54	01010100
Established Timings	23	Established timings 1 (00h if not used)	00	00000000
	24	Established timings 2 (00h if not used)	00	00000000
	25	Manufacturer’s timings (00h if not used)	00	00000000
Standard Timing ID	26	Standard timing ID1 (01h if not used)	01	00000001
	27	Standard timing ID1 (01h if not used)	01	00000001
	28	Standard timing ID2 (01h if not used)	01	00000001
	29	Standard timing ID2 (01h if not used)	01	00000001
	2A	Standard timing ID3 (01h if not used)	01	00000001
	2B	Standard timing ID3 (01h if not used)	01	00000001
	2C	Standard timing ID4 (01h if not used)	01	00000001
	2D	Standard timing ID4 (01h if not used)	01	00000001
	2E	Standard timing ID5 (01h if not used)	01	00000001
	2F	Standard timing ID5 (01h if not used)	01	00000001
	30	Standard timing ID6 (01h if not used)	01	00000001
	31	Standard timing ID6 (01h if not used)	01	00000001
	32	Standard timing ID7 (01h if not used)	01	00000001
33	Standard timing ID7 (01h if not used)	01	00000001	
	34	Standard timing ID8 (01h if not used)	01	00000001
	35	Standard timing ID8 (01h if not used)	01	00000001

Samsung Secret

Timing Descriptor #1	36	Pixel Clock/10,000 (LSB)	F5	11110101
	37	Pixel Clock/10,000 (MSB)	1D	00011101
	38	Horizontal Active = xxxx pixels (lower 8 bits)	56	01010110
	39	Horizontal Blanking (Thbp) = xxxx pixels (lower 8 bits)	FC	11111100
	3A	Horizontal Active/Horizontal blanking (Thbp) (upper4:4 bits)	50	01010000
	3B	Vertical Active = xxxx lines	00	00000000
	3C	Vertical Blanking (Tvbp) = xxxx lines (DE Blanking typ. for DE only panels)	16	00010110
	3D	Vertical Active : Vertical Blanking (Tvbp) (upper4:4 bits)	30	00110000
	3E	Horizontal Sync, Offset (Thfp) = xxxx pixels	30	00110000
	3F	Horizontal Sync, Pulse Width = xxxx pixels	20	00100000
	40	Vertical Sync, Offset (Tvfp) = xx lines Sync Width = xx lines	25	00100101
	41	Horizontal Vertical Sync Offset/Width upper 2 bits	00	00000000
	42	Horizontal Image Size =xxx mm	58	01011000
	43	Vertical image Size = xxx mm	C2	11000010
	44	Horizontal Image Size / Vertical image size	10	00010000
	45	Horizontal Border = 0 (Zero for Notebook LCD)	00	00000000
	46	Vertical Border = 0 (Zero for Notebook LCD)	00	00000000
47	Bit[7] 0: Non-interlace, 1: Interlace Bit[6:5] 00: Normal display, no strero, XX: See table xx for definition Bit[4:3] 00: Analog composite, 01: Bipolar analog composite, 10: Digital composite, 11: Digital separate Bit[2:1] :The interpretation of bits 2 and 1 is dependent on the decode of bits 4 and 3 - see Table 3.18. Bit[0] :See Table VESA EDID spec for definition Referenced Default = 1Ah	1A	00011010	
Timing Descriptor #2	48	Pixel Clock/10,000 (LSB)	D6	11010110
	49	Pixel Clock/10,000 (MSB)	12	00010010
	4A	Horizontal Active = xxxx pixels (lower 8 bits)	56	01010110
	4B	Horizontal Blanking (Thbp) = xxxx pixels (lower 8 bits)	A0	10100000
	4C	Horizontal Active/Horizontal blanking (Thbp) (upper4:4 bits)	50	01010000
	4D	Vertical Active = xxxx lines	00	00000000
	4E	Vertical Blanking (Tvbp) = xxxx lines (DE Blanking typ. for DE only panels)	16	00010110
	4F	Vertical Active : Vertical Blanking (Tvbp) (upper4:4 bits)	30	00110000
	50	Horizontal Sync, Offset (Thfp) = xxxx pixels	30	00110000
	51	Horizontal Sync, Pulse Width = xxxx pixels	20	00100000
	52	Vertical Sync, Offset (Tvfp) = xx lines Sync Width = xx lines	25	00100101
	53	Horizontal Vertical Sync Offset/Width upper 2 bits	00	00000000
	54	Horizontal Image Size =xxx mm	58	01011000
	55	Vertical image Size = xxx mm	C2	11000010
	56	Horizontal Image Size / Vertical image size	10	00010000
	57	Horizontal Border = 0 (Zero for Notebook LCD)	00	00000000
	58	Vertical Border = 0 (Zero for Notebook LCD)	00	00000000
59	Bit[7] 0: Non-interlace, 1: Interlace Bit[6:5] 00: Normal display, no strero, XX: See table xx for definition Bit[4:3] 00: Analog composite, 01: Bipolar analog composite, 10: Digital composite, 11: Digital separate Bit[2:1] :The interpretation of bits 2 and 1 is dependent on the decode of bits 4 and 3 - see Table 3.18. Bit[0] :See Table VESA EDID spec for definition Referenced Default = 1Ah	1A	00011010	

Samsung Secret

Timing Descriptor #3 Dell specific information	5A	Flag	00	00000000
	5B	Flag	00	00000000
	5C	Flag	00	00000000
	5D	Data Type Tag: Alphanumeric Data String (ASCII)	FE	11111110
	5E	Flag	00	00000000
	5F	Dell P/N 1 st Character	34	00110100
	60	Dell P/N 2 nd Character	59	01011001
	61	Dell P/N 3 rd Character	34	00110100
	62	Dell P/N 4 th Character	47	01000111
	63	Dell P/N 5 th Character	4D	01001101
	64	LCD Supplier EEDID Revision # Bit[7] : 0=X, 1=A Bit[6:0] : 00, 01, 02... for SST 10, 11, 12... for PT 20, 21, 22... for ST 00, 01, 02... for X-Build (if Bit[7]=1)	80	10000000
	65	Manufacturer P/N	31	00110001
	66	Manufacturer P/N	35	00110101
	67	Manufacturer P/N	36	00110110
	68	Manufacturer P/N	41	01000001
	69	Manufacturer P/N	54	01010100
6A	Manufacturer P/N	0A	00001010	
6B	Manufacturer P/N (If <13 char, then terminate with ASCII code 0Ah, set remaining char = 20h)	20	00100000	
Timing Descriptor #4	6C	Flag	00	00000000
	6D	Flag	00	00000000
	6E	Flag	00	00000000
	6F	Data Type Tag: Manufacturer Specified Data 00	00	00000000
	70	Flag	00	00000000
	71	Color Management (True Color Depth, 2-bit FRC)	00	00000000
	72	Panel Type & Configurations (Bulb/LED string #, Structure Revision, Panel Structure)	41	01000001
	73	Frame Rate Details (SDRRS, DRRS, Max Frame Rate, Min Frame Rate)	01	00000001
	74	Light Controller Interface and Maximum Typical Luminance	96	10010110
	75	Front Surface / Polarizer and Pixel Structure (Transflective, AG/Glossy)	00	00000000
	76	Multi-Media Features (Dynamic Backlight Control, Color Management)	00	00000000
	77	Multi-Media Features (Active Gamma Control, Motion Blur)	00	00000000
	78	Special Features #1 (In-Cell Scanner, Wireless)	00	00000000
	79	Special Features #2 (In-Cell Touch, Interface, Over Drive, LVDS Channel or eDP Lane)	01	00000001
7A	Special Features #3 (3D, E-Privacy, BIST Support)	01	00000001	
Checksum	7B	(If <13 char, then terminate with ASCII code 0Ah, set remaining char = 20h)	0A	00001010
	7C	(If <13 char, then terminate with ASCII code 0Ah, set remaining char = 20h)	20	00100000
	7D	(If <13 char, then terminate with ASCII code 0Ah, set remaining char = 20h)	20	00100000
7E	Extension flag (# of optional 128 EDID extension blocks to follow, Typ = 0)	00	00000000	
7F	Checksum (The 1-byte sum of all 128 bytes in this EDID block shall = 0)	CF	11001111	

Samsung Secret