



MODEL: MT3151A05-1

Ver. 2.2

Date: 29.Nov.2012

| Customer's Approval | | CSOT | |
|---------------------|------|------------------------------|------|
| Signature | Date | Approved By Product Director | Date |
| | | Name: Richard Lung | |
| | | Signature: | |
| | | Reviewed By PM Manager | Date |
| | | Name: Aaron Tu | |
| | | Signature: | |
| | | Reviewed By Project Leader | Date |
| | | Name: Richard Lung | |
| | | Signature: | |
| | | Reviewed By PM | Date |
| | | Name: Teng Ma | |
| | | Signature: | |

1. General Description

1.1 Product Features

- HD Resolution (1366 x 768)
- Brightness: 300 cd/m²
- Very High Contrast Ratio: 3000:1
- Fast Response Time
- Color Saturation: 62% NTSC
- Ultra Wide Viewing Angle: 178° (H)/178° (V) (CR ≥ 10)
- Low Power Consumption: Typ. 36 W
- DE (Data Enable) Mode
- LVDS (Low Voltage Differential Signaling) Interface
- ROHS Compliance

1.2 Overview

MT3151A05-1 is a diagonal 31.5" color active matrix LCD module with edge LED backlight and 1ch-LVDS interface. This module is a transmissive type display operating in the normally black mode. It supports 1366 x 768 HD resolution and can display up to 16.7M colors (8-bit). Each pixel is divided into Red, Green and Blue sub-pixels which are arranged in horizontal stripe. The converter of backlight is built-in.

This module dedicates for LCD TV products and provides excellent performance which includes high contrast ratio, ultra wide viewing angle, low power consumption and high color depth.

1.3 General Information

| Item | Specification | Unit | Note |
|-------------------------|--|-------------------|---------------------------------|
| Active Area | 697.685 (H) x 392.256 (V) | mm | |
| Bezel Opening Area | 705.4 (H) x 400.0 (V) | mm | |
| Outline Dimension | 735.4 (H) x 433.0 (V) x 10.8 (D) | mm | D: From Bezel to Rear (Thinner) |
| Weight | 4.5 | kg | Max. |
| Driving Scheme | a-Si TFT Active Matrix | - | |
| Number of Pixels | 1366 x 768 | pixel | |
| Pixel Pitch (Sub Pixel) | 0.51075 (H) x 0.17025 (V) | mm | |
| Pixel Arrangement | RGB Horizontal Stripe | - | |
| Display Colors | 16.7 M | color | 8-bit |
| Display Mode | Transmissive Mode, Normally Black | - | |
| Surface Treatment | Anti-glare, Haze 2%, Hard Coating (3H) | - | |
| Luminance of White | 300 | cd/m ² | Center Point, Typ. |

2. Absolute Maximum Ratings

2.1 Absolute Maximum Ratings ($T_A = 25 \pm 2 \text{ }^\circ\text{C}$)

The followings are maximum values which, if exceeded, may cause damage to the unit.

| Item | Symbol | Value | | Unit |
|-------------------------|----------|-------|------|------|
| | | Min. | Max. | |
| Power Supply Voltage | V_{CC} | - 0.3 | 13.5 | V |
| Input Signal Voltage | V_{IN} | - 0.3 | 3.6 | V |
| Converter Input Voltage | V_{BL} | 0 | 30 | V |
| Control Signal Level | - | - 0.3 | 7.0 | V |

2.2 Environment Requirement

(1) Temperature and relative humidity range are shown as below.

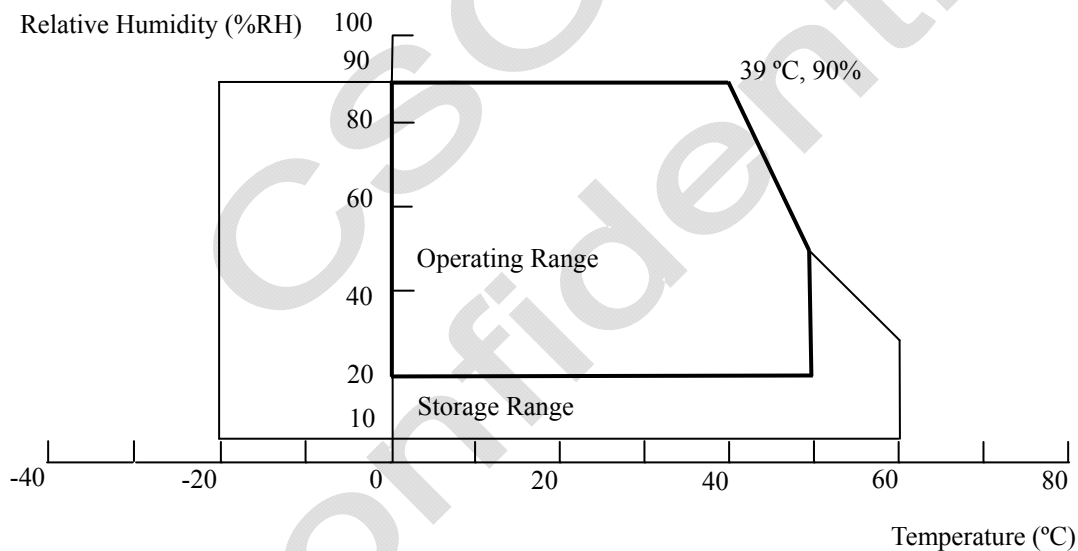

Fig. 2.1 Operating and storage environment

- (a) 90%RH maximum ($T_A < 39 \text{ }^\circ\text{C}$).
- (b) Wet-bulb temperature should be $39 \text{ }^\circ\text{C}$ maximum ($T_A > 39 \text{ }^\circ\text{C}$).
- (c) No condensation.

(2) The storage temperature is between $-20 \text{ }^\circ\text{C}$ to $60 \text{ }^\circ\text{C}$, and the operating ambient temperature is between $0 \text{ }^\circ\text{C}$ to $50 \text{ }^\circ\text{C}$.

The maximum operating temperature is based on the test condition that the surface temperature of display area is less than or equal to $65 \text{ }^\circ\text{C}$ with LCD module in a temperature controlled chamber alone. Thermal management should be considered in final product design to prevent the surface temperature of display area from being over $65 \text{ }^\circ\text{C}$. The range of operating temperature may degrade in case of improper thermal management in the end product design.

(3) The TFT module including glass should be avoided any shock or vibration.

While testing shock and vibration, the fixture holding the module should be assured to be hard and rigid enough to prevent the module twisted or bent by the fixture. The test conditions should be less than:

Shock (Non-operating): 35 G, 11 ms, half sine wave, 1 time for $\pm X$, $\pm Y$, $\pm Z$.

Vibration (Non-operating): Random 1.0 Grms, 10 ~ 200 Hz, 10 min, 1 time for each X, Y, Z.

2.3 Package Storage

When storing modules as spares for a long time, please follow the precaution instructions:

- (1) Do not store the module in high temperature and high humidity for a long time. It is highly recommended to store the module with temperature from 0 °C to 35 °C in normal humidity.
- (2) The module shall be stored in a dark area and avoided to be exposed in direct sunlight or fluorescent light.

CSOT
Confidential

3. Electrical Specification

3.1 Electrical Characteristics

3.1.1 Power Consumption ($T_A = 25 \pm 2 \text{ }^\circ\text{C}$)

| Parameter | Symbol | Value | | | Unit | Note | |
|----------------------|-----------------|----------|------|------|------|------|-----|
| | | Min. | Typ. | Max. | | | |
| Power Supply Voltage | V_{CC} | 10.8 | 12.0 | 13.2 | V | (1) | |
| Rush Current | I_{RUSH} | - | - | 3 | A | (2) | |
| Power Supply Current | White Pattern | I_{CC} | - | 0.2 | 0.3 | A | (3) |
| | Vertical Stripe | I_{CC} | - | 0.4 | 0.5 | A | |
| | Black Pattern | I_{CC} | - | 0.2 | 0.3 | A | |

Note:

- (1) The ripple voltage should be controlled less than 10% of V_{CC} .
- (2) Measurement condition: V_{CC} rising time = 470 μs .

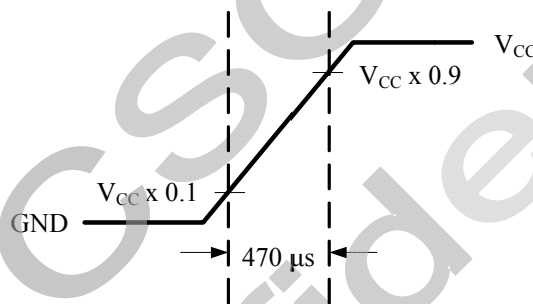

Fig. 3.1 V_{CC} rising time condition

- (3) Measurement condition: $V_{CC} = 12 \text{ V}$, $T_A = 25 \pm 2 \text{ }^\circ\text{C}$, $F = 60 \text{ Hz}$. The test patterns are shown as below.

A. White Pattern



C. Black Pattern



B. Vertical Pattern

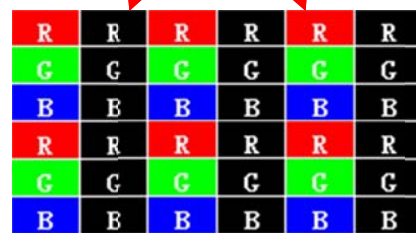
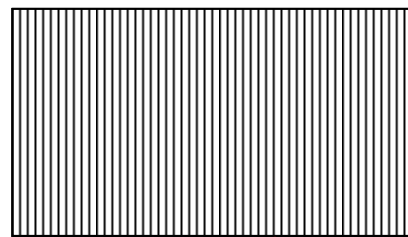

Fig. 3.2 Test patterns

3.1.2 LVDS Characteristics

| Parameter | Symbol | Value | | | Unit | Note | |
|----------------|---|------------|-------|------|-------|------|-----|
| | | Min. | Typ. | Max. | | | |
| LVDS Interface | Differential Input High Threshold Voltage | V_{TH} | + 100 | - | - | mV | (1) |
| | Differential Input Low Threshold Voltage | V_{TL} | - | - | - 100 | mV | |
| | Common Input Voltage | V_{CM} | 1.0 | 1.2 | 1.4 | V | |
| | Differential Input Voltage | $ V_{ID} $ | 200 | - | 600 | mV | |
| | Terminating Resistor | R_T | - | 100 | - | ohm | |
| CMOS Interface | Input High Threshold Voltage | V_{IH} | 2.7 | - | 3.3 | V | |
| | Input Low Threshold Voltage | V_{IL} | 0 | - | 0.6 | V | |

Note:

(1) The LVDS input signal has been defined as follows:

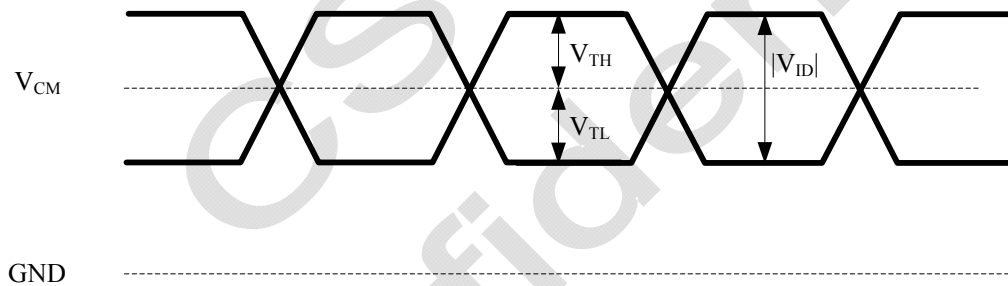

Fig. 3.3 LVDS input signal

3.2 Backlight Converter Unit

3.2.1 LED Converter Electrical Characteristics ($T_A = 25 \pm 2 \text{ }^\circ\text{C}$)

| Parameter | Symbol | Condition | Value | | | Unit | Note | |
|------------------------------|--------------|----------------|----------------|------|------|------|------|--|
| | | | Min. | Typ. | Max. | | | |
| Power Consumption | P_{BL} | $V_{BL} = 24V$ | - | 25 | - | W | (1) | |
| Input Voltage | V_{BL} | - | 22.8 | 24.0 | 25.2 | V | | |
| Input Current | I_{BL} | $V_{BL} = 24V$ | - | 1.04 | 1.3 | A | (1) | |
| Input Inrush Current | I_{RS-VIN} | $V_{BL} = 24V$ | - | - | 2.7 | A | (2) | |
| | | | - | - | 5 | A | | |
| On/Off Control Voltage | On | V_{BLON} | $V_{BL} = 24V$ | 2.5 | - | 5.0 | V | |
| | Off | | $V_{BL} = 24V$ | 0 | - | 0.8 | V | |
| On/Off Control | - | I_{BLON} | $V_{BL} = 24V$ | - | - | 1.5 | mA | |
| PWM Dimming Control Voltage | Max. | V_{P-DIM} | $V_{BL} = 24V$ | 2.4 | - | 5.0 | V | |
| | Min. | | $V_{BL} = 24V$ | 0 | - | 0.8 | V | |
| External PWM Control Current | I_{P-DIM} | $V_{BL} = 24V$ | - | - | 2 | mA | | |
| PWM Dimming Frequency | F_{P-DIM} | $V_{BL} = 24V$ | 140 | 180 | 240 | Hz | | |
| Min Dimming Duty Ratio | D_{P-DIM} | $V_{BL} = 24V$ | 10 | - | - | % | (3) | |
| DET Status Signal | DET HI | $V_{BL} = 24V$ | Open Collector | | | - | (4) | |
| | DET Low | $V_{BL} = 24V$ | 0 | - | 0.8 | V | | |
| Input Impedance | R_{IN} | $V_{BL} = 24V$ | 300 | - | - | Kohm | | |

Note:

- (1) Dimming ratio = 100% (Max.) ($T_A = 25 \pm 5 \text{ }^\circ\text{C}$, Turn on for 45minutes).
- (2) The measurement condition: V_{BL} rising time is 20 ms. (V_{BL} from 10% ~ 90%), the sequence diagram is shown as Fig. 3.4.
- (3) Normal: 0 ~ 0.8V; Abnormal: Open collector.

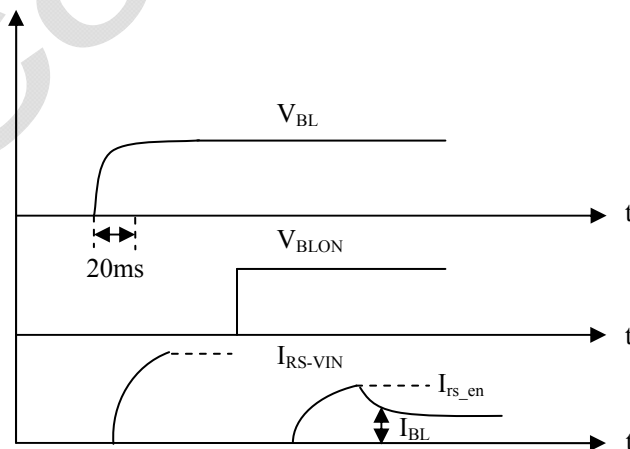

Fig. 3.4 The timing sequence diagram of inrush current measurement

3.2.2 LED Converter Power Sequence

| No. | Symbol | Min. | Typ. | Max. | Unit | Remark |
|-----|--------|------|------|------|------|--------------|
| 1 | T1 | 20 | - | - | ms | See Fig. 3.5 |
| 2 | T2 | 500 | - | - | ms | |
| 3 | T3 | 250 | - | - | ms | |
| 4 | T4 | 0 | - | - | ms | |
| 5 | T5 | 250 | - | - | ms | |

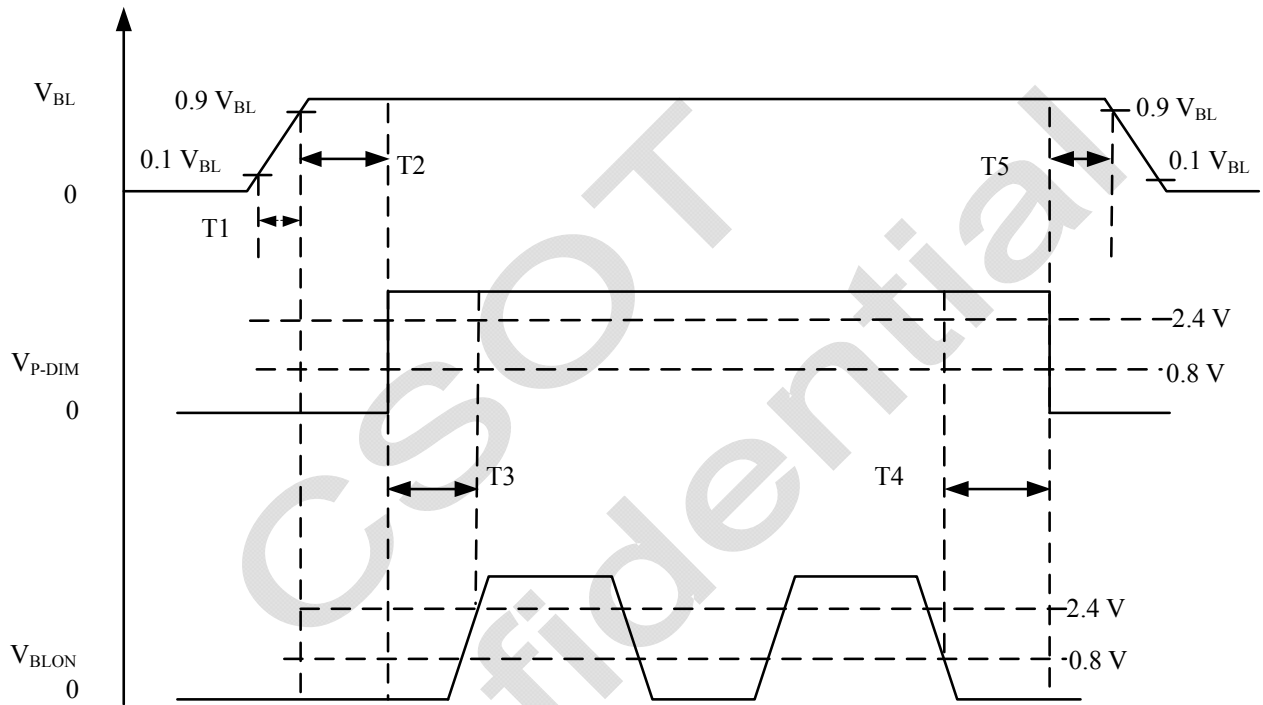

Fig. 3.5 The power sequence of V_{BL} and V_{BLON}

Attention:

The power sequence:

$$\text{On} = V_{BL} > V_{P-DIM} \geq V_{BLON}$$

$$\text{Off} = V_{BLON} \geq V_{P-DIM} > V_{BL}$$

4. Electrical Block Diagram

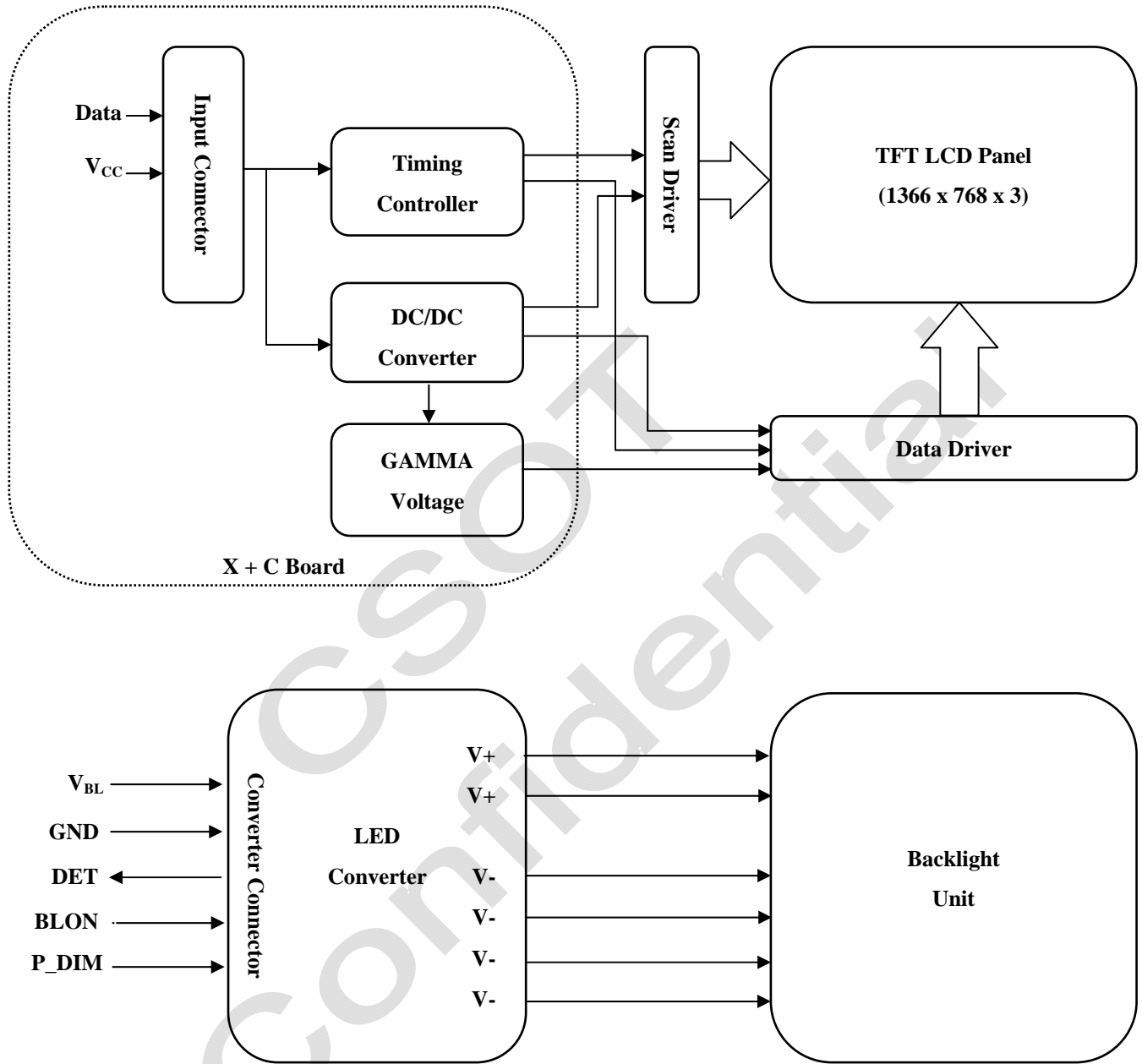

5. Input Terminal Pin Assignment

5.1 TFT LCD Module

X + C Board CN1: 300B30-0000RA-M4 (Starconn) or equivalent (see Note (1))

| Pin No. | Symbol | Description | Note |
|---------|-----------------|-----------------------------------|------|
| 1 | V _{CC} | Power Supply ,+ 12 V DC Regulated | |
| 2 | V _{CC} | Power Supply ,+ 12 V DC Regulated | |
| 3 | V _{CC} | Power Supply ,+ 12 V DC Regulated | |
| 4 | V _{CC} | Power Supply ,+ 12 V DC Regulated | |
| 5 | GND | Ground | |
| 6 | GND | Ground | |
| 7 | GND | Ground | |
| 8 | GND | Ground | |
| 9 | LVDS SEL | LVDS Data Format Selection | (2) |
| 10 | NC | For CSOT internal only | (3) |
| 11 | GND | Ground | |
| 12 | LV1N0 | 1st Channel LVDS Data Input (0-) | |
| 13 | LV1P0 | 1st Channel LVDS Data Input (0+) | |
| 14 | GND | Ground | |
| 15 | LV1N1 | 1st Channel LVDS Data Input (1-) | |
| 16 | LV1P1 | 1st Channel LVDS Data Input (1+) | |
| 17 | GND | Ground | |
| 18 | LV1N2 | 1st Channel LVDS Data Input (2-) | |
| 19 | LV1P2 | 1st Channel LVDS Data Input (2+) | |
| 20 | GND | Ground | |
| 21 | LVCK1N | 1st Channel LVDS Clock Input (-) | |
| 22 | LVCK1P | 1st Channel LVDS Clock Input (+) | |
| 23 | GND | Ground | |
| 24 | LV1N3 | 1st Channel LVDS Data Input (3-) | |
| 25 | LV1P3 | 1st Channel LVDS Data Input (3+) | |
| 26 | GND | Ground | |
| 27 | NC | For CSOT internal only | (3) |
| 28 | NC | For CSOT internal only | (3) |
| 29 | NC | For CSOT internal only | (3) |
| 30 | GND | Ground | |

Note:

(1) The direction of pin assignment is shown as below:

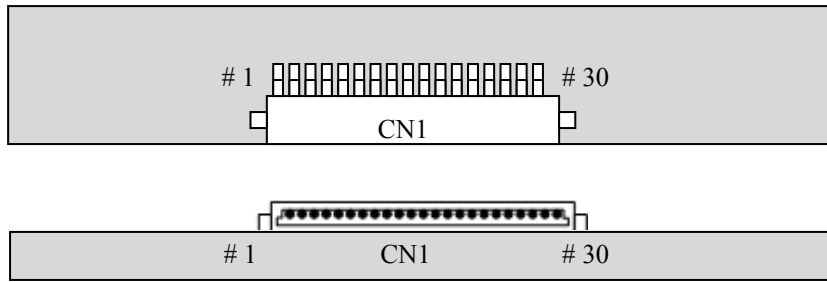

Fig. 5.1 LVDS connector direction sketch map

- (2) High: connect to + 3.3 V → JEIDA format; Low: connect to GND or Open → VESA format.
(3) For CSOT internal only, please let it open.

CSOT
Confidential

5.2 Converter Unit

5.2.1 Converter Input Connector Pin Definition

Converter Board CNF1: 50308-0140N-002 (ACES) or equivalent (see 4.2 Note (1))

| Pin No. | Symbol | Feature |
|---------|-----------------|---|
| 1 | V _{BL} | Power Supply, + 24V DC Regulated |
| 2 | | |
| 3 | | |
| 4 | | |
| 5 | | |
| 6 | GND | GND |
| 7 | | |
| 8 | | |
| 9 | | |
| 10 | | |
| 11 | DET | Normal (0 ~ 0.8V), Abnormal (Open Collector) (Recommend Pull high R > 10K, VDD = 3.3V)(Note (2)) |
| 12 | BLON | Back Light On/ Off |
| 13 | NC | No Connection |
| 14 | P_DIM | PWM Dimming Control (Open for 100%) |

Attention:

If the external PWM function is less than 5% dimming ratio, the judge conditions are as below:

(1) The direction of pin assignment is shown as below.

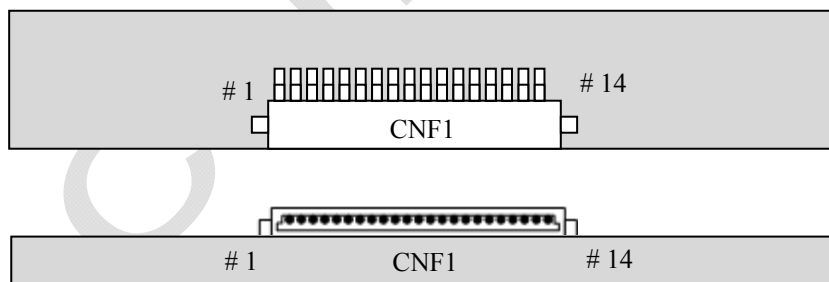
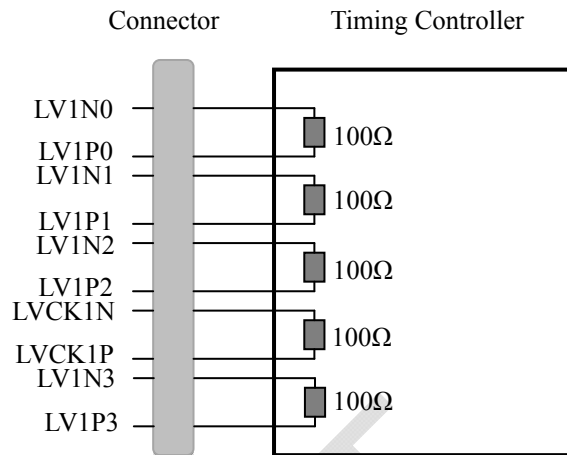

Fig. 5.2 Converter connector direction sketch map

(2) When open collector occur, the limit current resistor need to be connected to DET pin to prevent MOSFET from damage, the maximum drain current of MOSFET is 100mA.

5.3 Block Diagram of Interface



Attention:

- (1) LCD module uses a 100 ohms (Ω) resistor between positive and negative lines of each receiver input.
- (2) LVDS cable impedance shall be 50 ohms per signal line or about 100 ohms per twist-pair line respectively.

5.4 LVDS Interface

5.4.1 VESA Format (SELLVDS = L or Open)

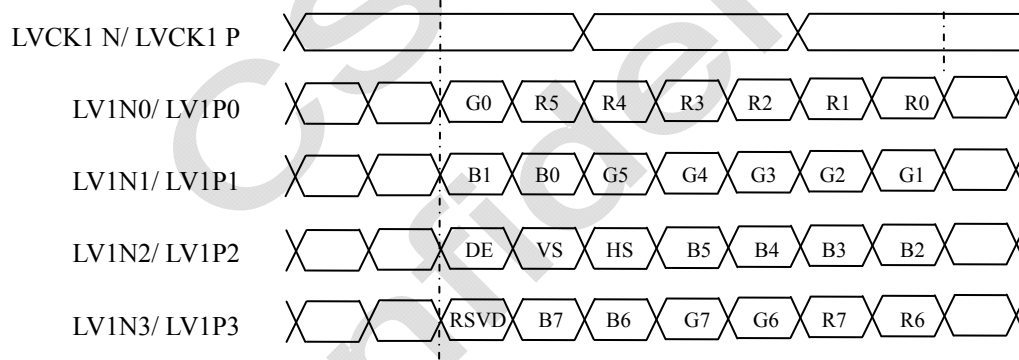

5.4.2 JEIDA Format (SELLVDS = H)

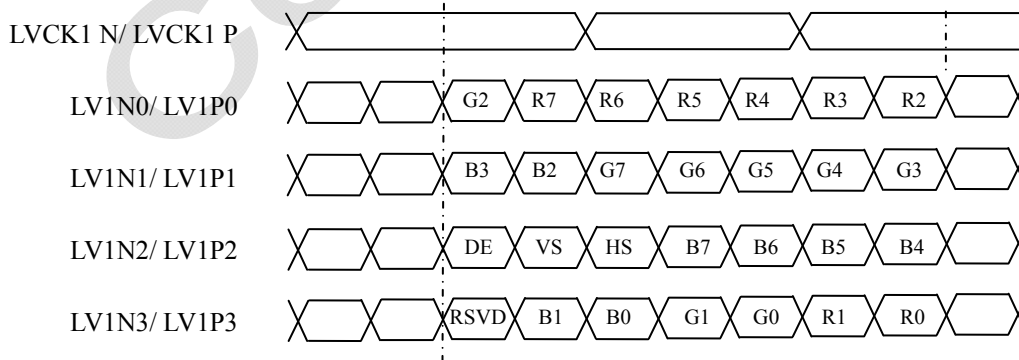

5.5 Color Data Input Assignment

The brightness of each primary color is based on the 8-bit gray scale data input for each color. The higher the binary input, the brighter the color. The table below provides the assignment of the color versus.

| Data Input Color | | Data Signal | | | | | | | | | | | | | | | | | | | | | | | |
|---------------------|------------------|-------------|----|----|----|-----|----|----|----|-------|----|----|----|-----|----|----|----|------|----|----|----|-----|----|----|----|
| | | Red | | | | | | | | Green | | | | | | | | Blue | | | | | | | |
| | | MSB | | | | LSB | | | | MSB | | | | LSB | | | | MSB | | | | LSB | | | |
| | | R7 | R6 | R5 | R4 | R3 | R2 | R1 | R0 | G7 | G6 | G5 | G4 | G3 | G2 | G1 | G0 | B7 | B6 | B5 | B4 | B3 | B2 | B1 | B0 |
| Basic Colors | Black | 0 | 0 | 0 | 0 | 0 | 0 | 0 | 0 | 0 | 0 | 0 | 0 | 0 | 0 | 0 | 0 | 0 | 0 | 0 | 0 | 0 | 0 | 0 | |
| | Red | 1 | 1 | 1 | 1 | 1 | 1 | 1 | 1 | 0 | 0 | 0 | 0 | 0 | 0 | 0 | 0 | 0 | 0 | 0 | 0 | 0 | 0 | 0 | |
| | Green | 0 | 0 | 0 | 0 | 0 | 0 | 0 | 0 | 1 | 1 | 1 | 1 | 1 | 1 | 1 | 1 | 0 | 0 | 0 | 0 | 0 | 0 | 0 | |
| | Blue | 0 | 0 | 0 | 0 | 0 | 0 | 0 | 0 | 0 | 0 | 0 | 0 | 0 | 0 | 0 | 0 | 1 | 1 | 1 | 1 | 1 | 1 | 1 | |
| | Cyan | 0 | 0 | 0 | 0 | 0 | 0 | 0 | 0 | 1 | 1 | 1 | 1 | 1 | 1 | 1 | 1 | 1 | 1 | 1 | 1 | 1 | 1 | 1 | |
| | Magenta | 1 | 1 | 1 | 1 | 1 | 1 | 1 | 1 | 0 | 0 | 0 | 0 | 0 | 0 | 0 | 0 | 1 | 1 | 1 | 1 | 1 | 1 | 1 | |
| | Yellow | 1 | 1 | 1 | 1 | 1 | 1 | 1 | 1 | 1 | 1 | 1 | 1 | 1 | 1 | 1 | 0 | 0 | 0 | 0 | 0 | 0 | 0 | 0 | |
| | White | 1 | 1 | 1 | 1 | 1 | 1 | 1 | 1 | 1 | 1 | 1 | 1 | 1 | 1 | 1 | 1 | 1 | 1 | 1 | 1 | 1 | 1 | 1 | |
| Gray Scale of Red | Red (0) / Dark | 0 | 0 | 0 | 0 | 0 | 0 | 0 | 0 | 0 | 0 | 0 | 0 | 0 | 0 | 0 | 0 | 0 | 0 | 0 | 0 | 0 | 0 | | |
| | Red (1) | 0 | 0 | 0 | 0 | 0 | 0 | 0 | 1 | 0 | 0 | 0 | 0 | 0 | 0 | 0 | 0 | 0 | 0 | 0 | 0 | 0 | 0 | | |
| | : | : | : | : | : | : | : | : | : | : | : | : | : | : | : | : | : | : | : | : | : | : | : | | |
| | : | : | : | : | : | : | : | : | : | : | : | : | : | : | : | : | : | : | : | : | : | : | : | | |
| | Red (254) | 1 | 1 | 1 | 1 | 1 | 1 | 1 | 0 | 0 | 0 | 0 | 0 | 0 | 0 | 0 | 0 | 0 | 0 | 0 | 0 | 0 | 0 | | |
| | Red (255) | 1 | 1 | 1 | 1 | 1 | 1 | 1 | 1 | 0 | 0 | 0 | 0 | 0 | 0 | 0 | 0 | 0 | 0 | 0 | 0 | 0 | 0 | | |
| Gray Scale of Green | Green (0) / Dark | 0 | 0 | 0 | 0 | 0 | 0 | 0 | 0 | 0 | 0 | 0 | 0 | 0 | 0 | 0 | 0 | 0 | 0 | 0 | 0 | 0 | 0 | | |
| | Green (1) | 0 | 0 | 0 | 0 | 0 | 0 | 0 | 0 | 0 | 0 | 0 | 0 | 0 | 0 | 1 | 0 | 0 | 0 | 0 | 0 | 0 | 0 | | |
| | : | : | : | : | : | : | : | : | : | : | : | : | : | : | : | : | : | : | : | : | : | : | : | | |
| | : | : | : | : | : | : | : | : | : | : | : | : | : | : | : | : | : | : | : | : | : | : | : | | |
| | Green (254) | 0 | 0 | 0 | 0 | 0 | 0 | 0 | 0 | 1 | 1 | 1 | 1 | 1 | 1 | 1 | 0 | 0 | 0 | 0 | 0 | 0 | 0 | | |
| | Green (255) | 0 | 0 | 0 | 0 | 0 | 0 | 0 | 0 | 1 | 1 | 1 | 1 | 1 | 1 | 1 | 0 | 0 | 0 | 0 | 0 | 0 | 0 | | |
| Gray Scale of Blue | Blue (0) / Dark | 0 | 0 | 0 | 0 | 0 | 0 | 0 | 0 | 0 | 0 | 0 | 0 | 0 | 0 | 0 | 0 | 0 | 0 | 0 | 0 | 0 | 0 | | |
| | Blue (1) | 0 | 0 | 0 | 0 | 0 | 0 | 0 | 0 | 0 | 0 | 0 | 0 | 0 | 0 | 0 | 0 | 0 | 0 | 0 | 0 | 0 | 1 | | |
| | : | : | : | : | : | : | : | : | : | : | : | : | : | : | : | : | : | : | : | : | : | : | : | | |
| | : | : | : | : | : | : | : | : | : | : | : | : | : | : | : | : | : | : | : | : | : | : | : | | |
| | Blue (254) | 0 | 0 | 0 | 0 | 0 | 0 | 0 | 0 | 0 | 0 | 0 | 0 | 0 | 0 | 0 | 1 | 1 | 1 | 1 | 1 | 1 | 0 | | |
| | Blue (255) | 0 | 0 | 0 | 0 | 0 | 0 | 0 | 0 | 0 | 0 | 0 | 0 | 0 | 0 | 0 | 1 | 1 | 1 | 1 | 1 | 1 | 1 | | |

Attention:

0: Low level voltage; 1: High level voltage.

6. Interface Timing

6.1 Timing Table (DE Only Mode)

| Signal | Item | Symbol | Min. | Typ. | Max. | Unit | Note |
|--------------------|--------------------------------------|------------------------------------|-----------------|------|-----------------|-----------|-------------------------|
| LVDS Clock | Frequency | F_{CLKIN} ($= 1 / T_{CLK}$) | 50.0 | 75.4 | 85.0 | MHz | (2) |
| | Input cycle to cycle jitter | T_{RCL} | — | — | 200 | ps | (3) |
| | Spread spectrum modulation range | F_{CLKIN_MOD} | $F_{CLKIN}-2\%$ | — | $F_{CLKIN}+2\%$ | MHz | (4) |
| | Spread spectrum modulation frequency | F_{SSM} | | | 200 | KHz | |
| LVDS Receiver Data | Receiver Skew Margin | T_{RSM} | -400 | | 400 | ps | (5) |
| Vertical Term | Frame Rate | F | 47 | 60 | 63 | Hz | |
| | Vertical Frequency | F_V | 47.0 | 48.4 | 60.9 | KHz | |
| | Total | T_V | 784 | 806 | 1015 | T_H | $T_V = T_{VD} + T_{VB}$ |
| | Display | T_{VD} | 768 | | | T_H | |
| | Blank | T_{VB} | 16 | 38 | 247 | T_H | |
| Horizontal Term | Total | T_H | 1460 | 1560 | 2000 | T_{CLK} | $T_H = T_{HD} + T_{HB}$ |
| | Display | T_{HD} | 1366 | | | T_{CLK} | |
| | Blank | T_{HB} | 94 | 194 | 634 | T_{CLK} | |

Attention:

(1) The module is operated in DE only mode, H sync and V sync input signal have no effect on normal operation.

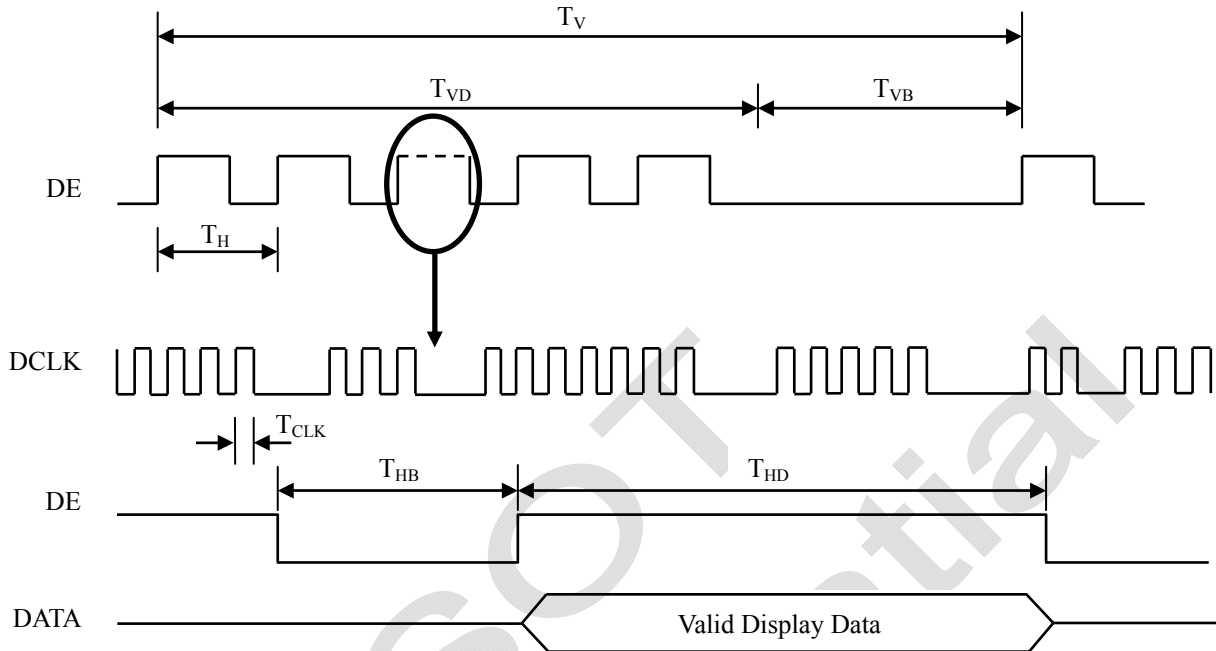

Fig. 6.1 Interface signal timing diagram

(2) Please make sure the range of pixel clock follows the following equations:

$$F_{CLKIN}(\max) \geq F(\max) \times T_V \times T_H$$

$$F(\min) \times T_V \times T_H \geq F_{CLKIN}(\min)$$

(3) The input clock cycle-to-cycle jitter is defined as the following figure. $T_{RCL} = |T_1 - T_2|$

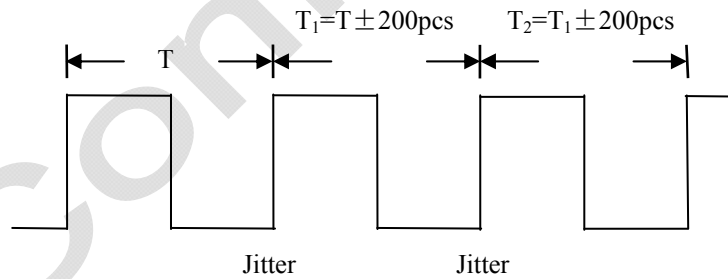

Fig. 6.2 The definition of the clock cycle-to-cycle jitter

(4) The SSCG (Spread Spectrum Clock Generator) is defined as the following figure.

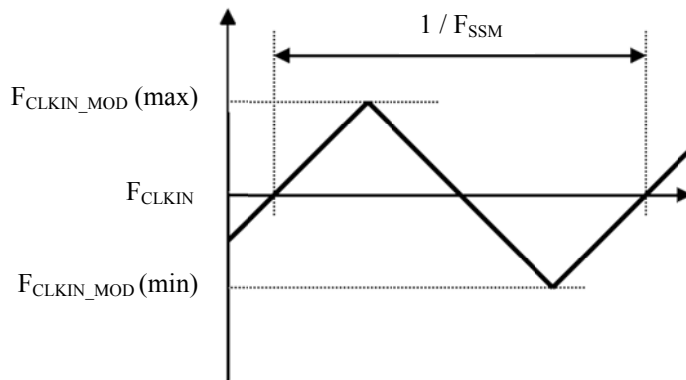

Fig. 6.3 The definition of SSCG

(5) The LVDS timing diagram and setup/hold time is defined and showed as the following figure.

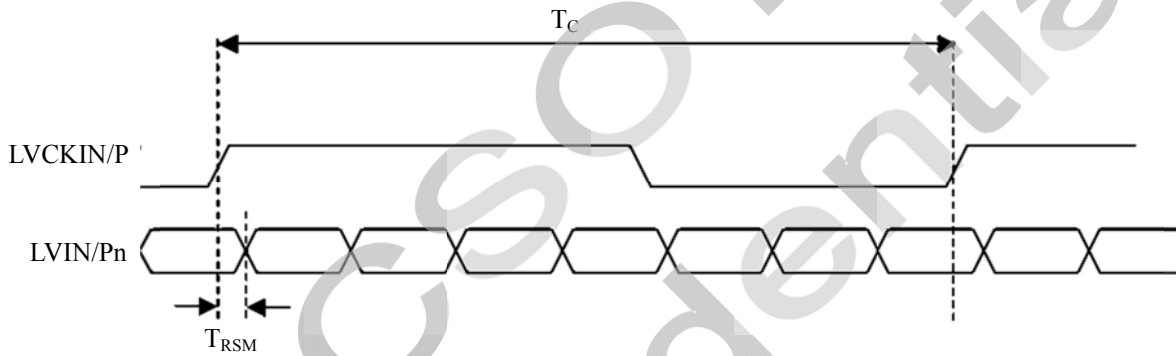

Fig. 6.4 The LVDS timing diagram and the definition of setup/hold time

6.2 Power On/Off Sequence

To prevent a latch-up or DC operation of LCD module, the power on/off sequence should be as the diagram below.

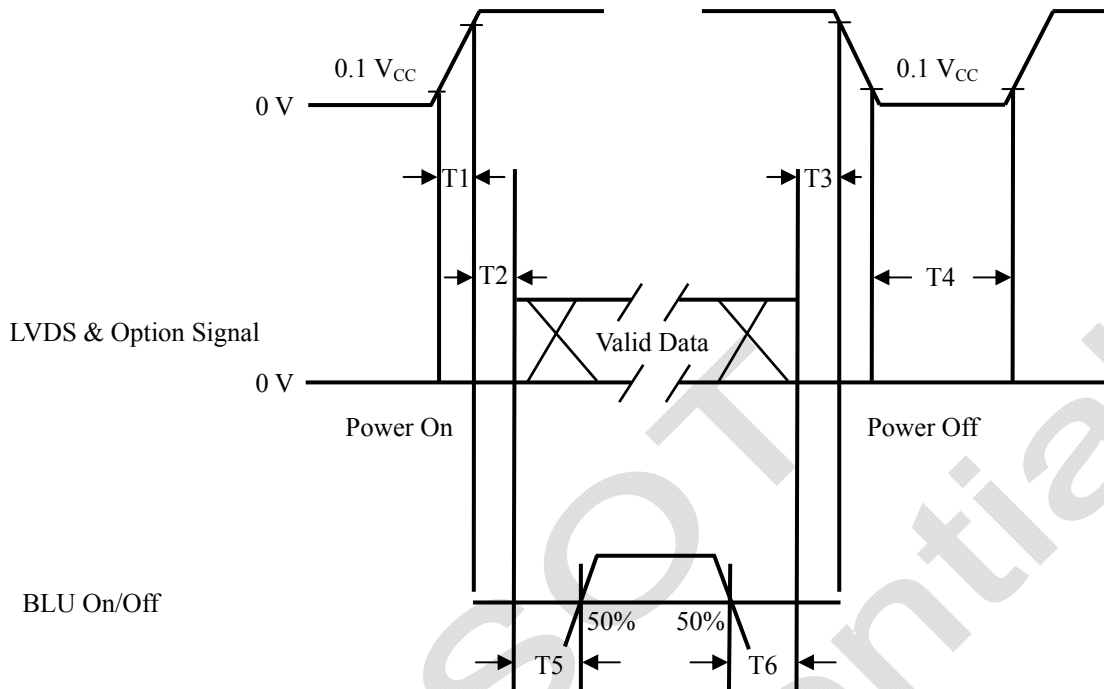

Fig. 6.2 Power On/Off Sequence

| Parameter | Values | | | Unit |
|-----------|--------|------|------|------|
| | Min. | Typ. | Max. | |
| T1 | 0.5 | - | 10 | ms |
| T2 | 0 | - | - | ms |
| T3 | 0 | - | - | ms |
| T4 | 1000 | - | - | ms |
| T5 | 500 | - | - | ms |
| T6 | 100 | - | - | ms |

Attention:

- (1) The supply voltage of the external system for the module input should follow the definition of V_{CC}.
- (2) Apply the lightbar voltage within the LCD operation range. When the backlight turns on before the LCD operation or the LCD turns off before the backlight turns off, the display may momentarily become abnormal screen.
- (3) In case that V_{CC} is in off level, please keep the level of input signals on the low or high impedance. If T2 < 0, that may cause electrical overstress.
- (4) T4 should be measured after the module has been fully discharged between power off and on period.
- (5) Interface signal shall not be kept at high impedance when the power is on.

7. Optical Characteristics

7.1 Measurement Conditions

The table below is the test condition of optical measurement.

| Item | Symbol | Value | Unit |
|-----------------------|---|-------------|--------------------|
| Ambient Temperature | T_A | 25 ± 2 | $^{\circ}\text{C}$ |
| Ambient Humidity | H_A | 50 ± 10 | % RH |
| LVDS Supply Voltage | V_{CC} | 12 | V |
| Driving Signal | Refer to the typical value in Chapter 3: Electrical Specification | | |
| LED Driving Current | I_L | 150 | mA |
| Vertical Refresh Rate | F_R | 60 | Hz |

To avoid abrupt temperature change during optical measurement, it's suggested to warm up the LCD module more than 45 minutes after lighting the backlight and in the windless environment.

To measure the LCD module, it is suggested to set up the standard measurement system as Fig. 7.1. The measuring area S should contain at least 500 pixels of the LCD module as illustrated in Fig. 7.2 (A means the area allocated to one pixel). In this model, for example, the minimum measuring distance Z is 370 mm when θ is 2 degree. Hence, 500 mm is the typical measuring distance. This measuring condition is referred to 301-2H of VESA FPDM 2.0 about viewing distance, angle, and angular field of view definition.

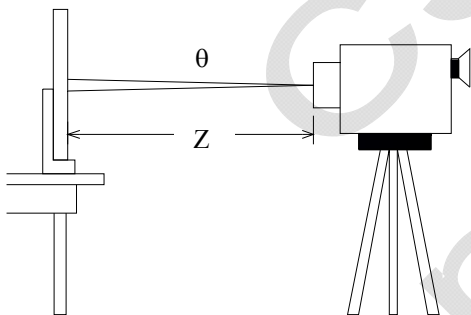

Fig. 7.1 The standard set-up system of measurement

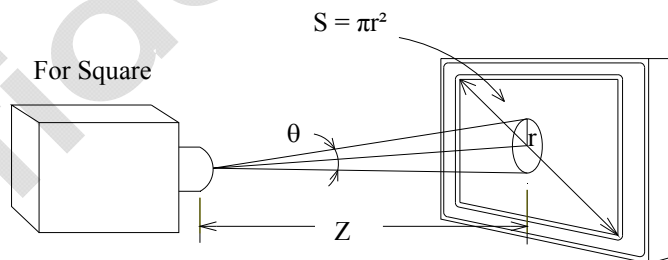

Fig. 7.2 The area S contains at least 500 pixels to be measured

$$N = \frac{S}{A} \geq 500 \text{ pixels}$$

N means the actual number of the pixels in the area S .

7.2 Optical Specifications

The table below of optical characteristics is measured by MINOLTA CS2000, MINOLTA CA310, ELDIM OPTI Scope-SA and ELDIM EZ Contrast in dark room.

| Item | | Symbol | Condition | Min. | Typ. | Max. | Unit | Note | | |
|------------------------------------|------------|---------------|--|------|--------|--------|-------------------|---------|---------|---|
| Static Contrast Ratio | | CR | $\theta_H = 0^\circ, \theta_V = 0^\circ$ Normal direction at center point of the LCD Module | 2400 | 3000 | - | - | (1) (2) | | |
| Response Time | | T_L | | - | 6.5 | - | ms | (3) | | |
| Center Luminance | | L_W | | 250 | 300 | - | cd/m ² | (2) (4) | | |
| Uniformity of White Screen | | - | | 70 | - | - | % | (2) (5) | | |
| Color Chromaticity (CIE1931) | Red | R_X | | Typ. | - 0.03 | Typ. | + 0.03 | - | (2) (6) | |
| | | R_Y | | | | | | 0.613 | | - |
| | Green | G_X | | | | | | 0.333 | | - |
| | | G_Y | | | | | | 0.331 | | - |
| | Blue | B_X | | | | | | 0.604 | | - |
| | | B_Y | | | | | | 0.153 | | - |
| | White | W_X | 0.071 | | | | | - | | |
| | | W_Y | 0.280 | | | | | - | | |
| Color Gamut | | CG | - | 62 | - | % NTSC | | | | |
| Viewing Angle | Horizontal | θ_{H+} | 80 | 89 | - | Deg. | (7) | | | |
| | | θ_{H-} | 80 | 89 | - | | | | | |
| | Vertical | θ_{V+} | 80 | 89 | - | | | | | |
| | | θ_{V-} | 80 | 89 | - | | | | | |

Note:

(1) Definition of static contrast ratio (CR):

It's necessary to switch off all the dynamic and dimming function when measuring the static contrast ratio.

$$\text{Static Contrast Ratio (CR)} = \frac{\text{CR-W}}{\text{CR-D}}$$

CR-W is the luminance measured by LMD (light-measuring device) at the center point of the LCD module with full-screen displaying white. The standard setup of measurement is illustrated in Fig. 7.3; CR-D is the luminance measured by LMD at the center point of the LCD module with full-screen displaying black. The LMD in this item is CS2000.

(2) The LMD in the item could be a spectroradiometer such as (KONICA MINOLTA) CS2000, CS1000(TOPCON), SR-UL2 or the same level spectroradiometer. Other display color analyzer (KONICA MINOLTA) CA210, CA310 or (TOPCON) BM-7 could be involved after being calibrated with a spectroradiometer on each stage of a product.

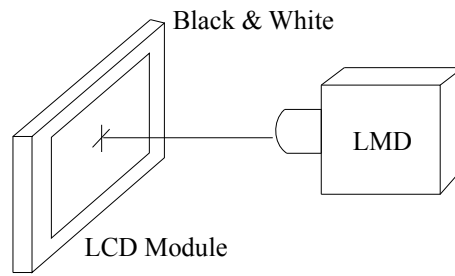

Fig. 7.3 The standard setup of CR measurement

(3) Response time T_L is defined as the average transition time in the response time matrix. The table below is the response time matrix in which each element $t_{X \text{ to } Y}$ is the transition time from luminance ratio X to Y. X and Y are two different luminance ratios among 0%, 25%, 50%, 75%, and 100% luminance. The transition time $t_{X \text{ to } Y}$ is defined as the time taken from 10% to 90% of the luminance difference between X and Y ($X < Y$) as illustrated in Fig.7.4. When $X > Y$, the definition of $t_{X \text{ to } Y}$ is the time taken from 90% to 10% of the luminance difference between X and Y. The response time is optimized on refresh rate $F_r = 60\text{Hz}$.

| Measured Transition Time | | Luminance Ratio of Previous Frame | | | | |
|----------------------------------|------|-----------------------------------|------------------------------|------------------------------|------------------------------|------------------------------|
| | | 0% | 25% | 50% | 75% | 100% |
| Luminance Ratio of Current Frame | 0% | | $t_{25\% \text{ to } 0\%}$ | $t_{50\% \text{ to } 0\%}$ | $t_{75\% \text{ to } 0\%}$ | $t_{100\% \text{ to } 0\%}$ |
| | 25% | $t_{0\% \text{ to } 25\%}$ | | $t_{50\% \text{ to } 25\%}$ | $t_{75\% \text{ to } 25\%}$ | $t_{100\% \text{ to } 25\%}$ |
| | 50% | $t_{0\% \text{ to } 50\%}$ | $t_{25\% \text{ to } 50\%}$ | | $t_{75\% \text{ to } 50\%}$ | $t_{100\% \text{ to } 50\%}$ |
| | 75% | $t_{0\% \text{ to } 75\%}$ | $t_{25\% \text{ to } 75\%}$ | $t_{50\% \text{ to } 75\%}$ | | $t_{100\% \text{ to } 75\%}$ |
| | 100% | $t_{0\% \text{ to } 100\%}$ | $t_{25\% \text{ to } 100\%}$ | $t_{50\% \text{ to } 100\%}$ | $t_{75\% \text{ to } 100\%}$ | |

$t_{X \text{ to } Y}$ means the transition time from luminance ratio X to Y.

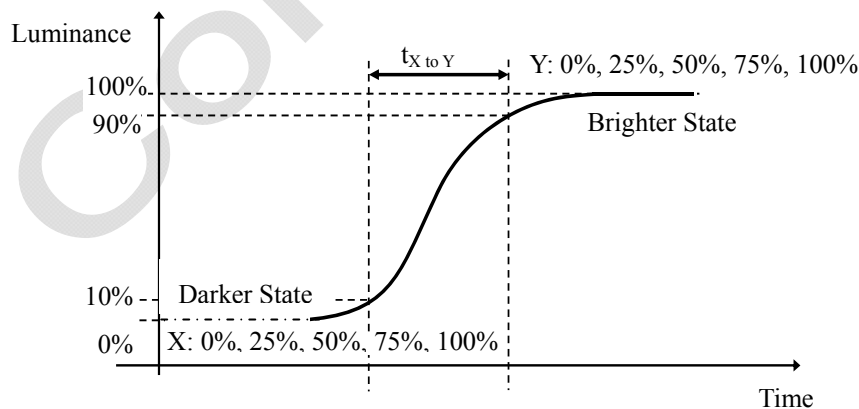

Fig. 7.4 The definition of $t_{X \text{ to } Y}$

All the transition time is measured at the center point of the LCD module by ELDIM OPTI Scope-SA.

(4) Definition of center luminance (L_w):

The luminance is measured at the center point of the LCD module with full-screen displaying white. Fig. 7.5 shows the standard setup of luminance measurement.

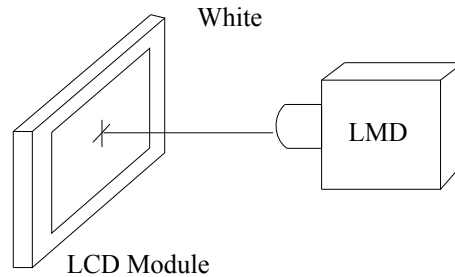

Fig. 7.5 The standard setup of luminance measurement

(5) Definition of uniformity of white screen:

The luminance L_i (i from 1 to 5) is measured at the 5 points defined in Fig. 7.6. H and V indicate active area.

From the measured set of luminance values L_i (i from 1 to 5), the minimum luminance is denoted as L_{\min} and the maximum luminance is denoted as L_{\max} . The uniformity of white screen is defined according to

$$\text{Uniformity} = L_{\min} / L_{\max} \times 100\%.$$

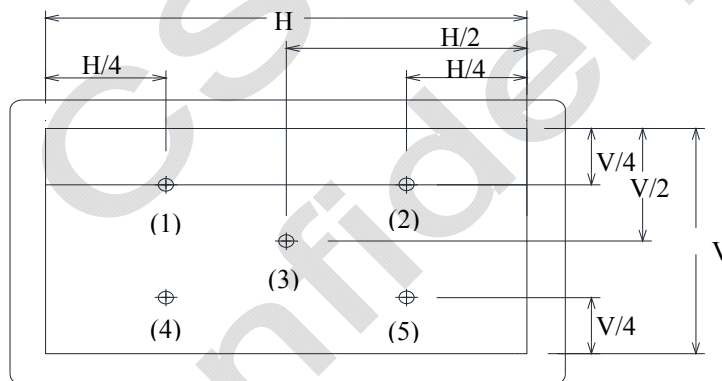

Fig. 7.6 Symbol “+” defines the 5 measuring locations (1), (2), (3) … (5)

(6) Definition of color chromaticity:

Each chromaticity coordinates (x , y) are measured in CIE1931 color space when full-screen displaying primary color R, G, B and white. The color gamut is defined as the fraction in percent of the area of the triangle bounded by R, G, B coordinates and the area is defined by NTSC 1953 color standard in the CIE color space. Chromaticity coordinates are measured by CS2000 and the standard setup of measurement is shown in Fig. 7.7.

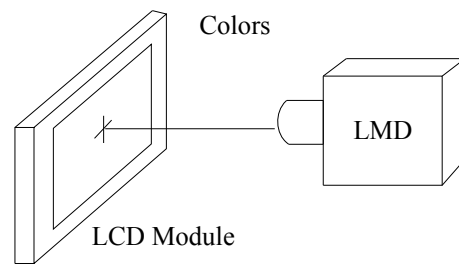

Fig. 7.7 The standard setup of color chromaticity measurement

(7) Definition of viewing angle coordinate system (θ_H , θ_V):

The contrast ratio is measured at the center point of the LCD module. The viewing angles are defined at the angle that the contrast ratio is larger than 10 at four directions relative to the perpendicular direction of the LCD module (two vertical angles: up θ_{V+} and down θ_{V-} ; and two horizontal angles: right θ_{H+} and left θ_{H-}) as illustrated in Fig. 7.8. The contrast ratio is measured by ELDIM EZ Contrast.

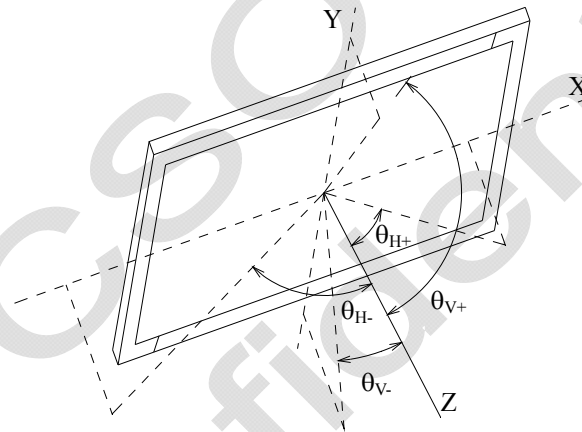

Fig. 7.8 Viewing angle coordination system

8.2 Packing

8.2.1 Packing Specifications

| Item | Specification | | |
|----------------------|------------------|---------------------------------------|--|
| | Quantity | Dimension (mm) | Weight (kg) |
| Packing Box | 24 pcs / box | 1140.0 (L) x 818.0 (W) x 505.0 (H) | Net Weight: 102.00 (Max.) Gross Weight: 110.80 (Max.) |
| Pallet | 1 | 1150.00 (L) x 850.00 (W) x 120.00 (H) | Net Weight: 5.04 |
| Stack Layer | 1 | | |
| Boxes per Pallet | 1 boxes / pallet | | |
| Pallet after Packing | 24 pcs / pallet | 1150 (L) x 850 (W) x 625 (H) | Gross Weight: 116 |

8.2.2 Packing Method

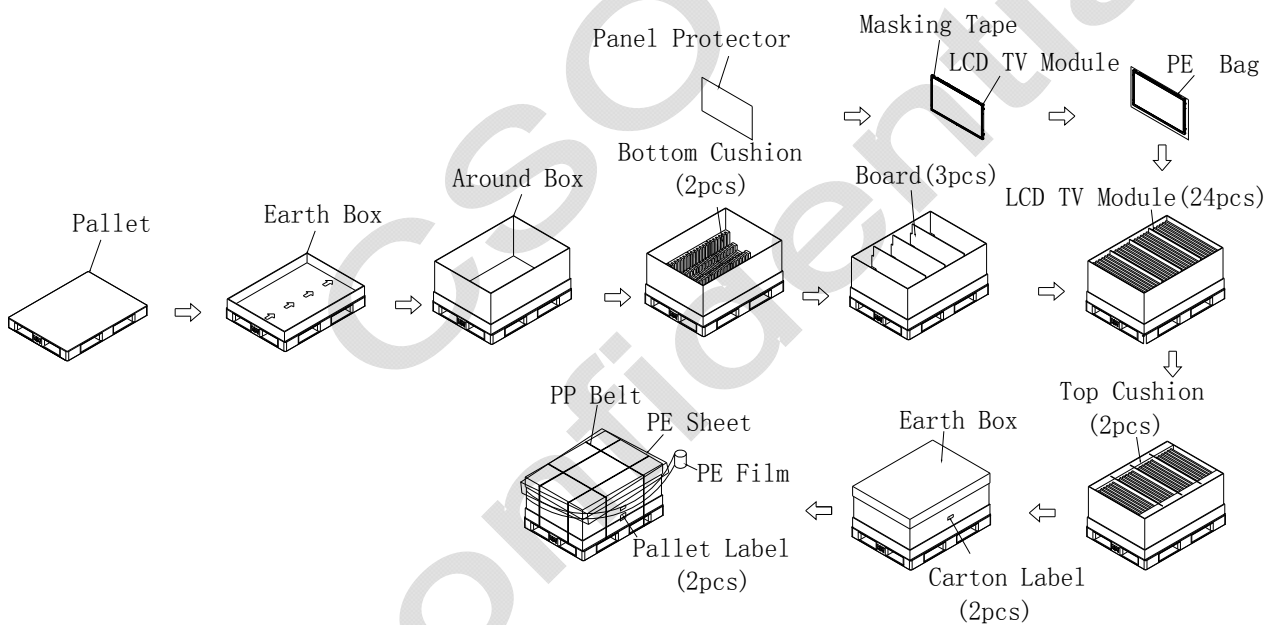
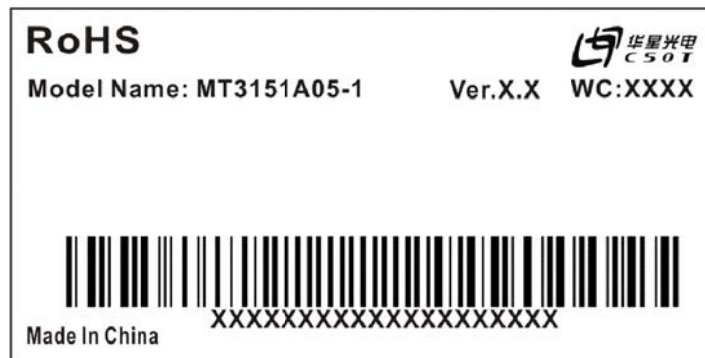

Fig. 8.1 Packing method (protector film stick on the front of the LCD module)

9. Definition of Labels

9.1 Module Label



For RoHS compliant products, CSOT will add RoHS for identification.

Model Name: MT3151A05-1

Ver. X.X: Version, for example: 0.1, 0.2, ..., 1.1, 1.2, ..., 2.1, 2.2, ...

WC (Week Code): XX XX

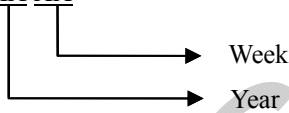

Year: 2010 = 10, 2011 = 11 ... 2020 = 20, 2021 = 21...

Week: 01, 02, 03 ...

Serial Number: XXXXXXXXXXXX XXXXXXXX

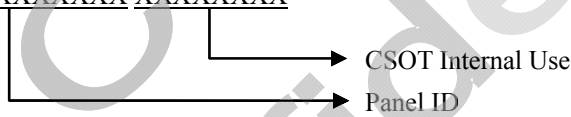

9.2 Carton Label

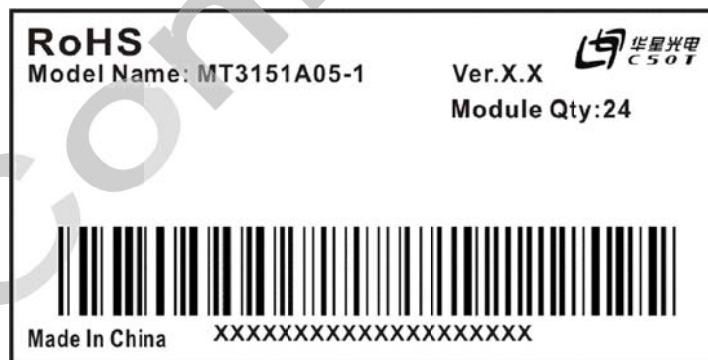

Serial Number: XXXXXXXX XX XXXXX XXXXX

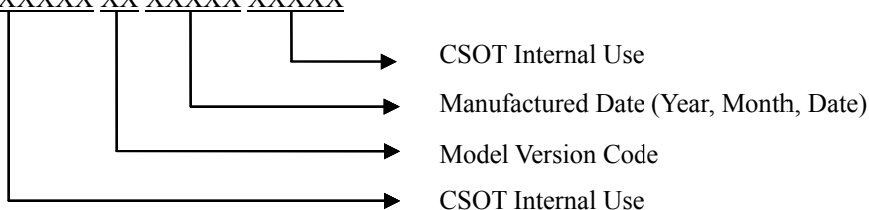

Manufactured Date:

Year: 2010 = 10, 2011 = 11...2020 = 20, 2021 = 21...

Month: 1~9, A~C, for Jan. ~ Dec.

Date: 01~31, for 1st to 31st

Model Version Code: Version of product, for example: 01, 02, 11, 12...

9.3 Pallet Label



Serial Number: XXXXXX XX XXXXXX XXXXXX

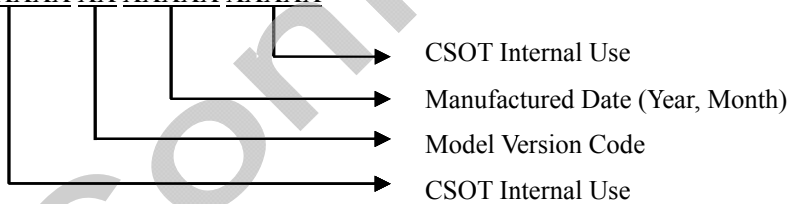

10. Precautions

10.1 Assembly and Handling Precautions

- (1) Do not apply rough force such as bending or twisting to the module during assembly.
- (2) It is recommended to assemble or install a module into the user's system in clean working areas. The dust and oil may cause electrical short or damage the polarizer.
- (3) Do not apply pressure or impulse to the module to prevent the damage to LCD panel and backlight.
- (4) Always follow the correct power-on sequence. This can prevent the damage and latch-up to the LSI chips.
- (5) Do not plug in or pull out the interface connector while the module is in operation.
- (6) Do not disassemble the module.
- (7) Use soft dry cloth without chemicals for cleaning because the surface of polarizer is very soft and easily be scratched.
- (8) Moisture can easily penetrate into the LCD module and may cause the damage during operation.
- (9) High temperature or humidity may deteriorate the performance of the LCD module. Please store LCD modules in the specified storage conditions.
- (10) When ambient temperature is lower than 10 °C, the display quality might be deteriorated. For example, the response time will become slow, and the starting voltage of LED light bar will be higher than that in room temperature.

10.2 Safety Precautions

- (1) If the liquid crystal material leaks from the panel, it should be kept away from the eyes or mouth. In case of contact with hands, skin or clothes, it has to be washed away thoroughly with soap.
- (2) After the module's end of life, it is not harmful in case of normal operation and storage.